



**SolarPower
Europe**

**Utility-scale solar O&M in Mexico
September 2018**



ATLAS RENEWABLE ENERGY

Company Highlights

- 1** Latin American renewable energy generation platform focused on high quality solar & wind assets with long-term offtake contracts.
- 2** Sponsored by Actis. Out of Fund 4 \$2.75Bn capital raise, some \$650m of equity is earmarked for Atlas Renewable Energy.
- 3** Experienced 60 person team with deep expertise in development, financing, construction and operations.
- 4** Atlas has an asset base of ~800 MWs in operating & contracted stage. Target ~1.2 GW of additional growth through M&A and organic development. **Projected EBITDA of >180\$MM / yr by 2020.**
- 5** Mgmt team track record in LatAm renewable sector since 2010. Track-record of >1 \$bn invested, 500MW constructed and over 1 GW developed in LatAm.



PILLARS OF EXPERTISE



CONTRACTED ASSET BASE

Chile



Javiera 69.5MW

- Asset: Solar
- Status: Operating
- PPA yrs: 20
- Location: Chanaral
- COD date: Q1 2015

Chile



Quiapilun 110MW

- Asset: Solar
- Status: Operating
- PPA yrs: 15
- Location: Colina
- COD date: Q1 2017

Uruguay



El Naranjal 59MW

- Asset: Solar
- Status: Operating
- PPA yrs: 30
- Location: Salto
- COD date: Q3 2017

Uruguay



Del Litoral 17MW

- Asset: Solar
- Status: Operating
- PPA yrs: 30
- Location: Salto
- COD date: Q3 2017

Projects under development:	Juazeiro - Brazil 155MW	Sao Pedro - Brazil 67MW	Sol de Futuro - Brazil 80MW	Sertao Solar- Brazil 112MW	Guajiro - Mexico 129.5MW
	● Asset: Solar	● Asset: Solar	● Asset: Solar	● Asset: Solar	● Asset: Solar
	● Status: Construction	● Status: Construction	● Status: Development	● Status: Development	● Status: Development
	● PPA yrs: 20	● PPA yrs: 20	● PPA yrs: 20	● PPA yrs: 20	● PPA yrs: 15 (20yr CELs)
	● Location: Bahia	● Location: Bahia	● Location: Fortaleza	● Location: Bahía	● Location: Hidalgo
	● COD date: Q4 2018	● COD date: Q3 2018	● COD date: Q4 2018	● COD date: 2020	● COD date: Q2 2019

O&M Mexican Market

Long Term Auctions

- According to SENER's Renewable Energy's Prospective 2017-2031, more than 5 GW of Solar PV Capacity are under construction stage or about to start construction.

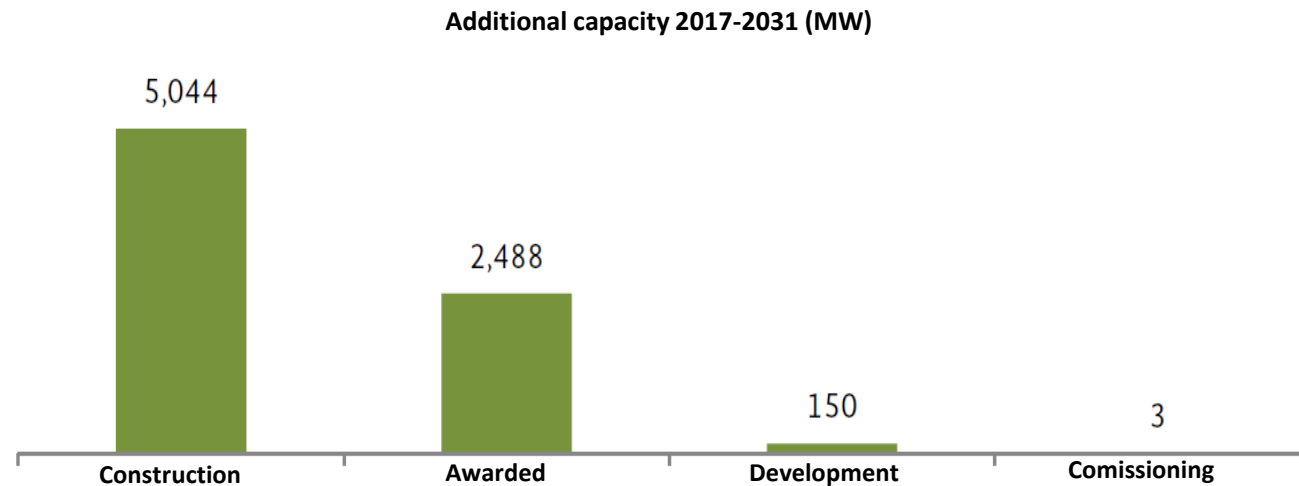

- This additional capacity is a result of the Long Term Auctions awarded projects:
 - 2,191 MW of Solar projects were awarded during the First Long Term Auction (March 2016) with a PPA COD of September 2018.
 - 1,933 MW of Solar Projects were awarded during the Second Long Term Auction (September 2016) with a PPA COD of June 2019.
 - 1,323 MW of Solar Projects were awarded during the Third Long Term Auction (September 2017) with a PPA COD of June 2020.



O&M Mexican Market

- Mexican market is still Young, but growing exponentially. It currently is one of the most attractive markets in the world.
- According to SolarPower Europe's Market Outlook, It is expected that in 2018, two more Gigawatts of installed capacity will be deployed in Mexico.
- It is expected that this trend will remain constant throughout the next years, thus, PV technology might reach a 20% share of the national Energy matrix by the year 2024.
- Most of the utility scale PV plants in Mexico are currently under the first two years of operation period, which means that are still under the EPC warranty period.



O&M Mexican Market

- In the Mexican Market EPC contractors usually offer O&M services as a natural extension of the EPC 2 year warranty period.
- Some of the most important EPC companies which offer O&M Services for Utility Scale Plants are:

- Grupo Avanzia



- Aldesa



- Gran Solar



- Grupo Ortiz





O&M Mexican Market

- Some of the most important O&M Worldwide providers with strong presence in Mexican Market are:

- SMA



- Solarig



- Ingeteam



O&M Contract structure in Mexico

Contract Scope of Works

A. Maintenance	Preventive maintenance	Corrective maintenance	
		Labor costs included	Spare part costs included
Solar modules	Y	Y	N
Solar trackers	Y	Y	N
Transformation centers	Y	Y	N
Any other component of the PV arrays (included but not limited to combiner boxes, cabling, level 2 electrical panels, etc.)	Y	Y	N
Plant's MV grid	Y	Y	N
Grid interconnection facilities	Y	Y	N
Monitoring system	Y	Y	N
Civil works (including but not limited to Plant's buildings, roads, fences, drainage system, etc.).	Y	Y	N
Weather stations	Y	Y	N
Any other auxiliary systems (security system, fire alarm system, etc.)	Y	Y	N

O&M Contract structure in Mexico

Contract Annex

A. Additional services to be included in the O&M contract scope

Module washing	1/ year for each Plant included in base price + fixed price for additional cleanings
Vegetation clearing	1/ year for each Plant included in base price + fixed price for clearings to be carried out at the Owner's convenience
Weather station calibration	1 / year
Physical surveillance (during night hours)	Y
Module thermography (please, propose sampling)	1 / year
Module I-V curve testing (please, propose sampling)	1 / year
Spare part management	Y
Warranty claims to equipment manufacturer	Y
Insurance	Y
Telecom	N
Mandatory technical inspections performed by an accredited company (If it proceeds)	Y
EHS management (*)	Y
Owner's remote access to the monitoring system	Y

O&M Contract structure in Mexico

Contract Annex

C. Reporting		
C.1	Monthly Report	Y
	Executive summary	Y
	Monthly plant's performance [PR, %]	Y
	Availability [%]	Y
	Monthly production [kWh]	Y
	Monthly irradiation [kWh/m ²]	Y
	Year-to-date (YTD) production [kWh]	Y
	Monthly & YTD Client's production Base Case comparison	Y
	Monthly & YTD Client's production Base Case irradiation adjusted comparison	Y
	Preventive maintenance (scheduled vs. Performed)	Y
	Corrective maintenance incidences	Y
	Warranty claims (incl. equipment, S/N, incidence description)	Y
	Improvement recommendations	Y
	Spare parts (in & out)	Y
	EHS incidences	Y
C.2	Quarterly Report	N
C.3	Annual Report	Y

O&M Contract structure in Mexico

Contract Annex- Warranties, Penalties & Bonus

D. O&M Warranties

D.1	Availability warranty	99%
D.2	PR Warranty	TBD
D.3	Maximum soiling loss warranty	N
D.4	Response period for failure identification & diagnosis	2 hours

E. Penalties

E.1	Availability penalty	10% of O&M annual contract price for each 1% below guaranteed yearly availability
------------	----------------------	---

F. Bonus

F.1	Availability bonus	[optional, to be proposed by the bidder if deemed appropriate]
------------	--------------------	--



O&M Focus in Atlas

- Current work being done in Atlas by the O&M team is mostly focused in measuring the Plant's production at different levels in order to yield better performance out of them.
- To achieve a more efficient measurement of the Plants production, Atlas is currently implementing new SCADA installation, new soiling assessment procedures, and constantly improving communications.
- The objective of these measurements is to validate models using real data to control all details in order to maximize yield in each project



SCADA GPM

Measurement points

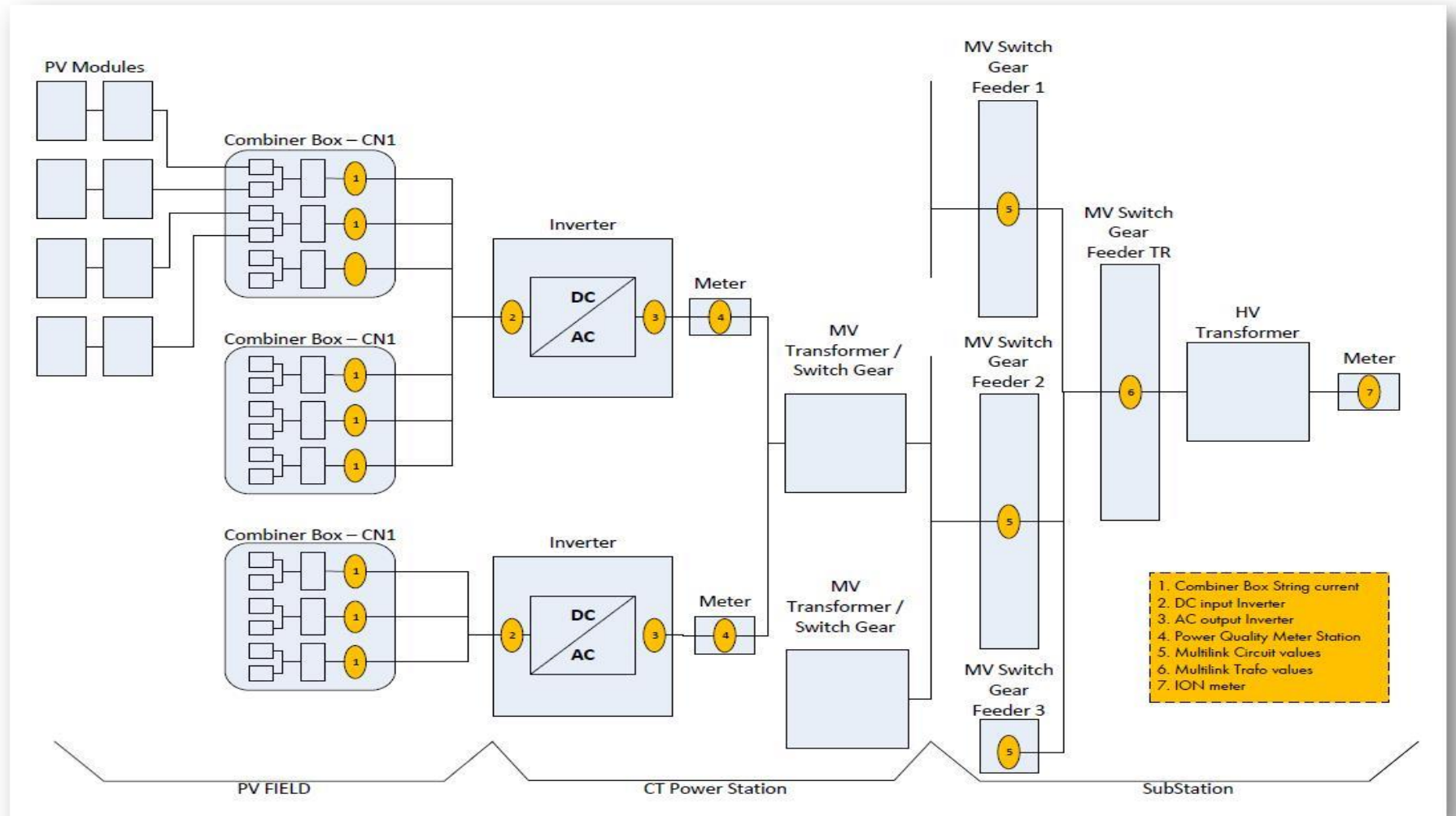



SCADA GPM

Measurement points

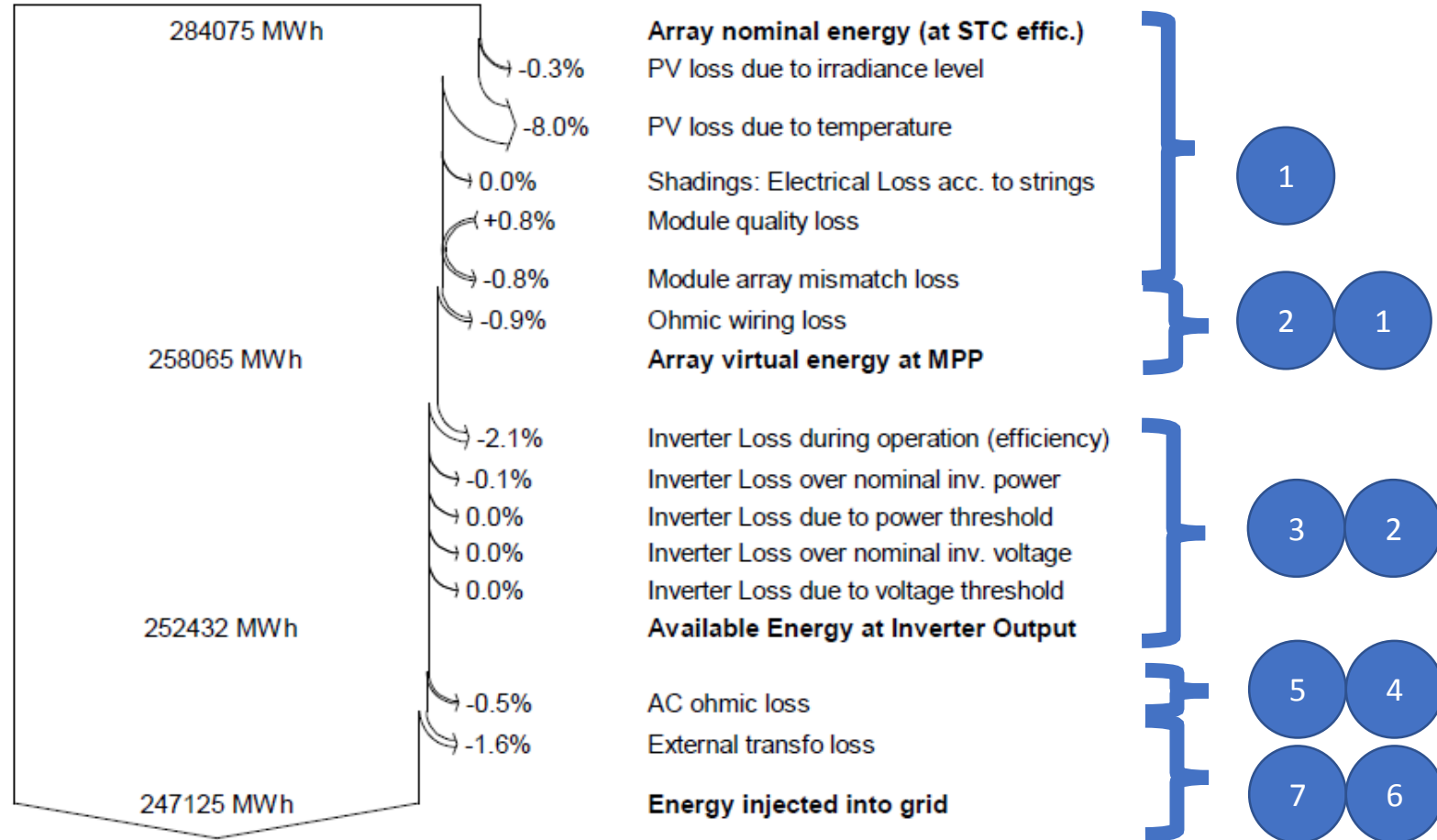



**Ops Session
08/2018**