



Toolkit on the Appraisal of Small Renewable Energy Projects

TANZANIA CASE STUDY



THE WORLD BANK



SWEDEN

Toolkit on the Appraisal of Small Renewable Energy Projects

TANZANIA CASE STUDY



THE WORLD BANK



SWEDEN

Triodos Facet
P.O. Box 55, 3700 AB Zeist
The Netherlands
T +31 (0)30 6933 766
F +31 (0)30 6923 936
E info@triodosfacet.nl
W www.triodosfacet.nl

World Bank
1818 H Street, NW
Washington, DC 20433
Dana Rysankova
T +1 (202) 458 9514
E drysankova@worldbank.org
W www.worldbank.org

REA
Director General
Rural Energy Agency
P.O. BOX 7990 Dar es Salaam, TANZANIA
T +255 22 241 2001-3
F +255 22 241 2007
E info@rea.go.tz
W www.rea.go.tz

July 2012

The material in this publication is copyrighted. Copying and/or transmitting portions or all of this work without permission may be a violation of applicable law. The World Bank encourages dissemination of its work and will normally grant permission to reproduce portions of the work promptly.

For permission to photocopy or reprint any part of this work, please send a request with complete information to *infoDev* Communications & Publications Department, 2121 Pennsylvania Avenue NW; Mailstop F 5P-503, Washington, DC 20433, USA; telephone: 202-458-4070; Internet: www.infodev.org; e-mail: info@infodev.org.

All other queries on rights and licenses, including subsidiary rights, should be addressed to the Office of the Publisher, The World Bank, 1818 H Street NW, Washington, DC 20433, USA; fax: 202-522-2422; e-mail: pubrights@worldbank.org.

Disclaimers

This report has been prepared with the utmost care, based on sources of information deemed reliable by the consultant. However, Triodos Facet does not assume any legal liability or responsibility for the accuracy, completeness, or usefulness of the information disclosed.

The findings, interpretations, and conclusions expressed herein are entirely those of the author(s) and do not necessarily reflect the view of the International Bank for Reconstruction and Development/The World Bank and its donors, its affiliated organizations, the Board of Executive Directors of the World Bank, or the governments they represent.

The World Bank cannot guarantee the accuracy of the data included in this work.

'The mission of Triodos Facet is to contribute to sustainable enterprise development'

TABLE OF CONTENTS

Acknowledgments	4
About the Authors.....	
Abbreviations	6
1 Introduction.....	8
2 Institutional and Policy Framework for Renewable Energy	10
3 Project Finance.....	17
4 Hydropower.....	35
5 Biomass.....	46
6 Biogas.....	58
7 Solar PV.....	63
8 Wind Power	70

Acknowledgments

Development of this reference manual was funded by the Swedish International Development Cooperation Agency Trust Fund for Support to the Electricity Access and Regulation in Tanzania. The trust fund is managed by the World Bank.

This reference manual was prepared by Triodos Facet, in the framework of capacity building program for local commercial banks on the appraisal of small renewable energy projects.

Some parts of this manual are based upon materials originally prepared by E+Co, a clean energy investment firm, and the Biomass Users Network Central America, under the United States Agency for International Development–funded Increased Use of Renewable Energy Resources Program for Central America.

The authors thank these parties for their gracious permission to adapt and use the materials for training activities in Tanzania.

About the Authors

This reference manual was developed by Triodos Facet. Triodos Facet is a consultancy company specialized in the promotion and development of sustainable small- and medium-sized enterprises. The principal authors of the reference manual are Nienke Stam, Joost Siteur and Joep Vonk, assisted by Fernando Alvarado, Mareike Hussels, Finias Magessa, Kofi Nketsia-Tabiri, Gonzalo Rico Calderón, and Ashington Ngigi.

The project was managed by Dana Rysankova (Senior Energy Specialist) and Raluca Golumbeanu (Energy Specialist) of the World Bank, with expert input from Krishnan Raghunathan (Financial Consultant), Anil Cabraal (Renewable Energy Consultant), Bernard Tenenbaum and Chris Greacen (Regulatory Consultants).

Abbreviations

AC	Alternating current
ADSCR	Annual debt service capacity ratio
AFD	Agence Française de Développement
BOD	Biological oxygen demand
BOOT	Build-own-operate-transfer
BoT	Bank of Tanzania
BOT	Build-operate-transfer
CAPEX	Capital expenditures
CERs	Certified emissions reductions
CDM	Clean Development Mechanism
CF	Cash flow
CHP	Combined heat and power
COD	Chemical oxygen demand
CPI	Consumer Price Index
DC	Direct current
DNO	Distribution network operator
DSCR	Debt service capacity ratio
DSRA	Debt service reserve account
EBITDA	Earnings before interest, taxes, and depreciation
EBT	Earnings before taxes
EE	Energy efficiency
EIA	Environmental impact assessment
EIB	European Investment Bank
EPC	Engineering, procurement, and construction
ESME	Energy SME
ESMF	Environmental and Social Management Framework
EU	European Union
EWURA	Energy and Water Utilities Regulatory Authority
FBC	Fluidized-bed combustor
GEF	Global Environment Facility
GHG	Greenhouse gas
IFC	International Finance Corporation
IPP	Independent power producer
IRR	Internal rate of return
kW	Kilowatt
kWh	Kilowatt hour
LOI	Letter of intent
MEM	Ministry of Energy and Minerals
MFI	Microfinance institution
MRA	Maintenance reserve account
MW	Megawatt
MWh	Megawatt hour
NEP	National Energy Policy
NGO	Nongovernmental organization
O&M	Operation and maintenance
OPEX	Operating costs
PoA	Program of activities
PPA	Power purchase agreement
R&D	Research and development
RE	Renewable energy
REA	Rural Energy Agency
REF	Rural Energy Fund
RPF	Resettlement Policy Framework
SHS	Solar home systems
SIDA	Swedish International Development Cooperation Agency
SMEs	Small- and medium-sized enterprises
SPC	Special purpose company
SPGD	Small power generation and distribution
SPP	Small power project
SPPA	Standardized power purchase agreement
SPPs	Small power projects
SPPT	Standardized power purchase tariff

SPV	Special purpose vehicle
SSMD	Sustainable solar market development
SV	Solar photovoltaic
TANESCO	Tanzania Electric Supply Company Limited
TAREA	Tanzania Renewable Energy Association
TaTEDO	Tanzania Traditional Energy Development and Environment Organization
TDBP	Tanzania Domestic Biogas Programme
TEDAP	Tanzania Energy Development and Access Project
TSh	Tanzanian shilling
UNDP	United Nations Development Programme
US\$	U.S. dollar
VAT	Value-added tax
W	Watt
Wp	Watt peak

CHAPTER 1 Introduction

Triodos Facet was contracted by the World Bank to implement technical assistance to financial institutions for the appraisal of small renewable energy (RE) projects in Tanzania. This manual serves as a reference for participants in the technical assistance program.

This first chapter gives an overview of the project's background and objectives (section 1.1) and details the overall structure of the manual (section 1.2).

1.1

BACKGROUND AND OBJECTIVES

This reference manual is part of the Tanzania Energy Development and Access Expansion Project (TEDAP). The objectives of the TEDAP are to (i) improve the quality and efficiency of the electricity service provision in the main growth centers of Dar es Salaam, Arusha and Kilimanjaro, and (ii) establish a sustainable basis for energy access expansion and renewable energy development in Tanzania. The project's global environmental objective is to abate greenhouse gas (GHG) emissions by using RE in rural areas to provide electricity.

The TEDAP consists of three components:

- A grid component (US\$85.8 million);
- A small power project (SPP) component (US\$41 million from the International Development Association [IDA], including additional financing, and US\$6.5 million from the Global Environment Facility [GEF]); and
- A technical assistance component (US\$3.2 million).

The TEDAP SPP component has four subcomponents: (i) small power generation and distribution (SPGD) subprojects, including renewable power generation and minigrids as well as a low-cost distribution pilot; (ii) sustainable solar market development (SSMD), supplying solar photovoltaic (SV) systems for public institutions and for individual households and businesses in rural areas; (iii) technical assistance to the Rural Energy Agency (REA) and other stakeholders; and (iv) a rural/renewable energy credit line.

The TEDAP has helped lay the groundwork for thriving private investments in RE projects by supporting the REA, developing an enabling regulatory framework, improving stakeholders' capabilities, and addressing the financing challenges. Several financing windows are provided under the TEDAP for SPP development: (i) matching grants for preinvestment support, business, and market development; (ii) connection performance grants for grid-connected and isolated minigrids to partially offset investment costs for new service connections; and (iii) a credit line that facilitates long-term lending (10–15 years) to rural RE projects through local financial institutions on commercial terms. The activities mentioned above have been supported by capacity building for stakeholders (energy sector institutions, private developers, commercial banks, and others) involved in the development of the RE program in Tanzania.

This manual is one of the tools aimed at developing the capacity of financial institutions to appraise RE projects. These tools are funded by the Swedish International Development Cooperation Agency (SIDA) Trust Fund, which is administered by the World Bank.

In more specific terms, the TEDAP assists financial institutions by providing:

- Classroom training on project finance and lending for RE projects; and
- On-the-job training for staff so that they can learn to appraise RE projects.

Training is targeted toward financial loan officers and credit department reviewers at financial institutions. Overall, through participation in these training activities, loan officers and reviewers will be able to:

- Understand the various aspects of making long-term loans for RE projects; and
- Evaluate and make decisions on extending financing to loan applications for RE projects.

The purpose of this reference manual is to contribute to achieving these training objectives. The manual was compiled following and incorporating the outcomes of the training sessions conducted in Tanzania in January and September 2011.

It should be noted that this manual should be read as a complement to, rather than as a substitution for, actual training. The manual is primarily meant for those who have participated in one or more of the classroom and on-the-job training sessions.

This reference guide is solely intended as an introduction to small RE project appraisal.

1.2

STRUCTURE OF THE MANUAL

Following this introductory chapter, chapter 2 continues with a general description of the regulatory, institutional, and policy environment for RE in Tanzania. The chapter describes the main existing institutional arrangements in place and shows that the country's legal framework is conducive to private sector RE initiatives.

Chapter 3 discusses the fundamentals of project finance, the basic components of financial analysis, and common due diligence factors concerning RE investments. This discussion provides a framework for a better understanding of RE financing, which from a bankers' point of view requires a different approach than the more traditional balance sheet-focused financing.

Chapters 4 through 8 go over each of the most common RE technologies:

- Chapter 4: Hydropower
- Chapter 5: Biomass
- Chapter 6: Biogas
- Chapter 7: Solar PV
- Chapter 8: Wind

Each of the chapters discusses both the basic technical and financial aspects of the technologies. Each chapter will provide the reader with a basic understanding of the technology in question and the associated financial challenges. In the chapters on hydropower (chapter 4) and biomass (chapter 5), a financial "back-of-the-envelope" model is included as well.

A financial analyst focused on only one RE technology should start with chapter 3 (Project Finance) and continue with the relevant technology chapter. For an understanding of the basic financial model of RE projects, the financial sections of chapters four and five can be read in isolation.

CHAPTER

2 Institutional and Policy Framework for Renewable Energy

This chapter provides an overview of the Tanzanian institutional and policy framework for renewable energy (RE) project development and finance. The chapter was developed based on information available in 2010. For updated information, visit the Web sites of the respective institutions.

2.1 INSTITUTIONAL LANDSCAPE OF THE ENERGY SECTOR

A number of institutions exist in Tanzania as partners and stakeholders in supporting RE technologies and services. This section introduces the main actors: the Ministry of Energy and Minerals (MEM), the Energy and Water Utilities Regulatory Authority (EWURA), the Rural Energy Agency (REA), Tanzania Electric Supply Company Limited (TANESCO), and a group of independent power producers (IPPs).

2.1.1 MEM AND OTHER GOVERNMENT DEPARTMENTS

The MEM oversees the energy sector at large. Other government departments that have responsibilities relating to the development of RE projects are the Environmental Division of the Vice President's Office, the Ministry of Natural Resources and Tourism (Forestry and Beekeeping Division), and the Prime Minister's Office for Regional Administration and Local Governments.

2.1.2 EWURA



EWURA is responsible for regulation of water and energy utilities in Tanzania.

EWURA is an autonomous, multisectoral regulatory authority established by the EWURA Act, Cap 414. The functions of the EWURA include:

- Issuing, renewing, and canceling licenses;
- Establishing standards for goods and services, including their supply;
- Setting rates and charges and/or establishing methods for regulation of rates and charges; and
- Monitoring performance in relation to levels of investment, availability, quantity and standard of services; the cost of services; and the efficiency of production and distribution of services.

In principle, anyone seeking to provide electricity services in Tanzania has to obtain a license from the EWURA. Only small power producers (SPPs) with a capacity below 1 megawatt (MW) are exempted from this licensing requirement. However, these SPPs are still required to register with the EWURA.

The EWURA may also issue provisional licenses to enable a project developer to carry out assessments, studies, and activities necessary for the preparation of a license application. An overview of the required steps and procedures for SPPs is provided in chapter 3.

To date, the EWURA's regulatory efforts have focused on SPPs of up to 10 MW that use renewable or cogeneration technologies. It is likely that regulatory policies for renewable generators larger than 10 MW will be developed on a case-by-case basis. Relevant

information about the development of small RE projects can be found at <http://www.ewura.go.tz/sppslectricity.html>.

2.1.3



REA, the Rural Energy Agency, promotes rural electrification.

THE REA AND THE RURAL ENERGY FUND

Established in 2005, the REA¹ and Rural Energy Fund (REF) are responsible for promoting access to modern energy services (including RE) for rural communities in Tanzania. The REA operates under the supervision of the MEM.

The REA was established to:

- Promote, stimulate, facilitate, and improve modern energy access for social and productive use in rural areas;
- Promote the rational and efficient production and use of energy;
- Finance eligible rural energy projects (through the REF); and
- Facilitate activities of key stakeholders interested in rural energy.

The REA is partnering with the World Bank for the implementation of the Tanzania Energy Development and Access Project (TEDAP), which aims to improve access for the rural population to modern energy supplies in an environmentally and socially sustainable manner. Several financing windows are provided under the TEDAP for SPP development:

- Matching grants for preinvestment support and business and market development (up to US\$100,000 per year).
- Connection performance grants for grid-connected and isolated minigrids to partially offset investment costs for new service connections (US\$500 per connection).
- A credit line in the amount of US\$25 million that facilitates long-term lending (10–15 years) to rural and RE projects through local financial institutions on commercial terms. The TEDAP credit line operating guidelines specify that the banks are expected to finance RE projects by using normal commercial banking practices. The operating guidelines² only put conditions on the minimum grace period (covering the project's construction period) and the loan tenor (minimum seven years). The World Bank does not impose constraints on the interest rate spread banks can apply. That is, the banks establish the interest rate to charge to the RE project themselves. Furthermore, the commercial banks also bear the full financial and credit risk for the loan to the RE project sponsor.

The REA and REF also support solar photovoltaic (SV) systems under the TEDAP with US\$2 per watt peak (Wp). The subsidy is limited to up to 100 Wp for residential systems and up to 300 Wp for institutions. Larger projects may be eligible on a case-by-case basis.

In addition to the mechanisms already described, **the REA plans to implement two other support mechanisms: an RE program of activities (PoA) and the energy small- and medium-sized enterprise (ESME) grant project.** Both mechanisms are designed to overcome the difficulties private RE investors face mobilizing equity. The mechanisms would facilitate timely access to future cash flows from carbon emission reductions. These mechanisms are outlined briefly in the following sections.

REA is developing the PoA to support small RE project developers in claiming **carbon credits**. Usually carbon credits are disbursed after projects are commissioned. Taking into consideration the need of local developers for additional revenues to fill the equity gap and reach financial closure, the REA has established a Green Performance Grant Facility under the ESME project financed by the Russian Federation Trust Fund executed by the World Bank. Therefore, the REA will sign agreements with the project developers for eligible projects, and will disburse green generation performance grants based on megawatts of RE. The new green generation performance grants under the ESME project will be in the value of expected future certified emission reductions (CERs). The REA's Green Performance Grant Facility is expected to be replenished by carbon revenues once these are generated by the ESME facility-supported subprojects.

¹ More information about the REA is available at <http://www.rea.go.tz>.

² TEDAP credit line operating guidelines are available at <http://www.rea.go.tz/LinkClick.aspx?fileticket=%2BNUqjtma8Rg%3D&tabid=144&mid=554>.

These carbon revenues will then be used as additional REA performance grants to support additional small RE projects. In all, the ESME project would allow developers to access their future carbon revenues at the time they need them most.

The green generation performance grants will complement the connection performance grant window existing under the TEDAP, which was described above. The grant application requirements, process, and payment schedule will follow the same procedures that are already established for the connection performance grant for the TEDAP.

2.1.4



TANESCO is the main electricity generator and distributor.

THE NATIONAL UTILITY: TANESCO

The Tanzanian electricity sector is dominated by TANESCO, which carries out generation, transmission, distribution, and supply. TANESCO operates the grid system and isolated supply systems in Kagera, Kigoma, Rukwa, Ruvuma, Mtwara, and Lindi.³ TANESCO also buys electricity from IPPs to distribute to customers. The contribution of RE technologies, other than large hydropower, to grid electricity is currently still less than 5 percent.⁴ TANESCO has recently established an SPP cell to provide a central point of contact for SPPs. The SPP cell is receiving advice from consultants who have been involved in developing a very successful SPP program in Thailand.

INDEPENDENT POWER PRODUCERS

In addition to TANESCO, there are private or public entities that generate electric power for sale to the utility and endusers: these are referred to as IPPs. In 1992, the Tanzanian government lifted its energy monopoly to allow private sector involvement in the electricity industry. This major policy reform enabled IPPs to operate in the energy generation segment. Private players include Independent Power Tanzania Limited (100 MW), Songas (190 MW) and Artumas, which operates a gas-to-power scheme in the Mtwara and Lindi regions (18 MW). Other IPPs are the leased emergency plants, namely Aggreko (40 MW), Dowans (100 MW), and Alstom (40 MW). Further, interconnections with Zambia and Uganda enable imports of relatively small amounts of electricity. Due to the participation of these IPPs, the once hydro-power-dominated power mix of Tanzania is now close to a 55/45 ratio between hydropower and thermal plants.

2.1.6

SMALL POWER PRODUCERS

In the *Electricity (Development of Small Power Projects) Rules, 2012* (authorized under section 45 of the Electricity Act [Cap 131]), an SPP is defined as an "entity generating electricity using renewable energy, fossil fuels, a cogeneration technology, or some hybrid system combining fuel sources [...] and either sells the generated power at wholesale to a DNO or sells at retail directly to end customers or some combination of the two. An SPP may have an installed capacity greater than 10 MW but may only export power outside of its premises not exceeding 10 MW." A major difference between the larger IPPs and SPPs is that the IPPs negotiate individualized power purchase agreements (PPAs) and tariffs with TANESCO while SPPs sell under standardized PPAs and standardized tariffs.

The REA maintains a database on the pipeline of SPPs (table 1). By February 2012, the REA database contained 58 projects at various stages of development. The vast majority of projects for which estimates of capacity yet to be installed are available are small hydropower projects (37 small hydropower projects with a total capacity of 121 MW), biomass projects (two biomass projects would have a capacity of 17 MW), grid connected, and isolated minigrids.

³ EWURA, <http://www.ewura.com/electricity.html>.

⁴ MEM (2010), Overview of Energy Sector. <http://www.mem.go.tz/modules/documents/index.php?action=downloadfile&filename=OVERVIEW%20OF%20ENERGY%20SECTOR%202010.pdf&directory=Energy%20Sector&>

Table 1: REA SPP Pipeline, February 2012

Technology	Number of projects	Number of projects with MW estimate	MW estimate
Biogas	1	0	n/a
Biomass	3	2	17
Hydro	48	37	121
Wind	6	0	n/a
Total	58	39	138

Source: REA.

2.2

POLICIES AND REGULATION

The government of Tanzania is committed to facilitating increased use of RE to support national development goals. As a result, a number of legal frameworks, policies, and strategies have been developed and enacted to provide a conducive atmosphere for industry growth. This section provides an overview of the most relevant policies and strategies adopted to help promote and facilitate increased use of RE in Tanzania.

The current National Energy Policy (NEP) was adopted in year 2003. Other important frameworks and strategies include the Rural Energy Act 2005 (which established the REA and REF), the EWURA Act 2001, and the Electricity Act 2008.

The objectives of the NEP are to ensure the availability of reliable and affordable energy supplies and the use thereof in a rational and sustainable manner to support national development goals.

Key statements in the NEP regarding RE projects include:

- Encourage efficient use of alternative energy sources;
- Ensure priority of power generation capacity based on indigenous resources;
- Facilitate research and development (R&D) and application of RE technologies for electricity generation;
- Facilitate increased availability of energy services, including grid and non-grid electrification in rural areas;
- Establish norms, codes of practice, standards, and guidelines for cost-effective rural energy supplies;
- Introduce and support appropriate fiscal, legal, and financial incentives for RE;
- Establish norms, codes of practice, guidelines, and standards for RE technologies to facilitate the creation of an enabling environment for sustainable development of RE sources;
- Ensure inclusion of environmental considerations in energy planning and implementation and enhance cooperation with other relevant stakeholders;
- Support R&D in RE technologies; and
- Promote entrepreneurship and private initiative in the production and marketing of products and services for rural and renewable energy.

2.3

MEM has issued a standardized power purchase agreement and a standardized power purchase tariff for small power projects

TARIFFS, PURCHASE AGREEMENTS, AND FISCAL ARRANGEMENTS

With support of the World Bank, the EWURA has issued a standardized power purchase agreement (SPPA) and a standardized power purchase tariff (SPPT) for SPPs.⁵ The SPPA and SPPT serve to streamline the development and interconnection of SPPs to main and minigrids and to set a platform to ensure a fair deal to all stakeholders. The SPPA is a relatively simple document that was developed to jumpstart SPP development in Tanzania. The following sections summarize the most relevant arrangements of SPPAs and SPPTs.

STANDARDIZED SMALL POWER PURCHASE AGREEMENT

An SPPA is a standard form of contract between an SPP developer and the distribution network operator (DNO) for the sale and purchase of electricity from RE sources with a

⁵ More information is available in EWURA's "Guidelines and Rules for Small Power Project Development," <http://www.ewura.go.tz/sppselectricity.html>.

maximum capacity of delivery of 10 MW. At present, the only DNO in Tanzania is TANESCO, the state-owned electricity enterprise.

The SPPA has the following major features:

- “Must-take” contract: all energy produced by the SPP will be purchased by the DNO (that is, TANESCO).
- The tariff is based on the DNO’s avoided costs and a different tariff is offered for dry season and wet season.
- The floor tariff over the term is 100 percent of the tariff in the year in which the SPPA is signed.
- The tariff is capped at 150 percent (Consumer Price Index [CPI] adjusted) of the tariff in the year the SPPA is signed.
- The SPPA has a term of 15 years, starting from date of operation.

The SPPA also includes duties and obligations binding the DNO and the SPP developer, including:

- Grid interconnection requirements (specifying power quality standards, relay, and other technical requirements for safe interconnection with the DNO grid);
- Metering arrangements;
- Billing and payment;
- Force majeure;
- Limitation of liability; and
- Dispute resolution.

All SPPs that do not sell electricity to a DNO are exempted from the obligation to execute an SPPA. For example, an SPP that builds and operates a new isolated minigrd will not have an SPPA because it would be selling at retail to final customers only.

To initiate the SPPA process, an SPP developer shall request a letter of intent (LOI) to “Interconnect an Embedded Generator to a DNO.” Section 3.6.2 provides a listing of the steps and procedures SPP developers have to complete in this process.

As of June 2012, five SPPAs have been signed for a total of 21 MW. Out of these five SPPAs, four projects are related to biomass and one involves hydropower. Two of these SPPs are currently selling power to the national utility, TANESCO.

In addition, nine potential SPPs have obtained an LOI. Together, once realized, these nine projects will add another 43 MW of installed capacity. Seven out of the nine SPPs are hydropower projects, the remaining two are biomass projects.

2.3.2

STANDARDIZED POWER PURCHASE TARIFF

The SPPT is a feed-in tariff that is based on estimates of TANESCO's avoided costs. It is a wholesale tariff because it is expected that the buyer, whether it is TANESCO or some other future DNO, will resell the power to retail customers. The expectation is that it will be computed by the EWURA in October of each year and approved by late November. In the event that the computation and approval of the new SPPT is delayed, purchases will be paid at the existing tariff until the new tariff becomes effective.

To protect both parties (the SPP developer and the DNO) against future price fluctuations, the SPP tariffs used in cases 1 and 2 in the table 2 include both a price floor and a price cap. The floor is equal to the tariff in the year in which the SPPA between the seller and the DNO is executed. That floor price is “locked in” for the duration of the power PPA to protect the SPP against possible reduction in the standardized tariff in future years. If the calculated tariff in a particular year goes below this floor, then the floor price will be applied. Similarly, if the calculated tariff rises above the price cap for a project signed in a particular year, then the price cap will be applied. The price cap equals 1.5 times the standardized tariff for the year the PPA is executed. The price cap will be adjusted annually to reflect changes in the CPI.

DNOs are required to establish an SPP coordinating unit to serve as a single point of contact for SPPs in interacting with various divisions of the DNO. These coordinating units are responsible for all matters related to the facilitation of SPPAs: building the interconnection, accepting and verifying invoices for electricity sales, monitoring, and other matters. As noted above, TANESCO has recently established an SPP cell to be the

single, initial point of contact for SPPs that wish to connect to TANESCO's main grid or to one of its isolated grids.

The four most likely SPP cases are set out in table 2. A number of proposed SPPs would combine cases 1 and 3. Detailed information about the calculation of tariffs for each case can be found in the SPP section of the EWURA's Web site (provided in section 2.3). Currently, the SPPT applies only to wholesale transactions by SPPs to a DNO, which is currently only TANESCO. It does not cover retail sales to final users (cases 3 and 4).

Table 2: The Four Most Likely SPP Cases

	Main grid	Isolated minigrid
Selling wholesale (currently TANESCO)	Case 1	Case 2
Selling retail (directly to final customers)	Case 3	Case 4

Source: Authors' compilation.

The 2011 values for SPP sales were TSh 121.13 per kilowatt hour (kWh) for sales to TANESCO on its main grid (case 1) and TSh 380.22 per kWh for sales to TANESCO on its minigrid (case 2). For the year 2012, the *proposed* base tariffs are TSh 152.54 per kWh for the main grid and TSh 480.50 per kWh for the minigrid.⁶ The EWURA Web site provides detailed information (including guidelines, methodology, and calculation) for both the SPPT main grid and the isolated grid.

The actual rates for sales to the main grid also depend on the season. During the dry season, for instance, rates tend to be higher to reflect the higher avoided cost, since output from lower-cost hydro plants decline in dry season. Table 3 shows how base, dry season, and wet season tariffs developed over 2009–12.

Table 3: Approved SPPTs (in TSh/kWh) during 2009–12

Period	2009	2010	2011	2012
Main grid connection				
Base tariff for the calendar year	96.11	110.30	121.13	152.54
Dry season (August to November)	115.33	132.36	145.36	183.05
Wet season (January to July, and December)	86.50	99.27	109.02	137.29
Minigrid connection				
Base tariff for the calendar year	334.83	368.87	380.22	480.50

Source: EWURA, <http://www.ewura.com>.

It should be noted that the SPPT, by definition, specifies tariffs for small RE power projects only (up to 10 MW). The tariffs for larger projects are subject to case-by-case negotiations between TANESCO and the supplier. The tariffs for both SPPs selling to the main grid and to isolated minigrids increased by more than 25 percent between 2011 and 2012. This reflects the fact that TANESCO's avoided costs increased considerably because of very expensive emergency power purchases.

2.3.3 RETAIL TARIFFS AND EWURA APPROVAL

RE projects, instead of selling to TANESCO, may also sell directly to end consumers. Retail sales tariffs have to be approved by the EWURA. The EWURA's SPP guidelines state:

“An SPP Developer selling directly to final (i.e., retail customers) must submit to EWURA an application for a cost-based tariff that is based on its own actual or projected total costs (expected to be largely generation and distribution costs) plus a reasonable profit for the portion of electricity sold to retail customers.”

By mid-2012, the EWURA had drafted amended rules and regulations addressing this issue in further detail. The draft amended rules establish principles for minimum and maximum acceptable retail tariffs based on operating costs, depreciation, debt, reserves, and reasonable profit. In this respect, the EWURA finds “tariffs that take into account ability to pay among different customer categories acceptable.” These rates, which the SPP should submit to the EWURA for approval, may be higher than the TANESCO national uniform tariff.

⁶ The *proposed* rates for 2012 were publicly announced by the EWURA on February 20, 2012, see http://www.ewura.com/pdf/SPPT/2012/SPPT_Public%20Notice_English_17Feb2012_FINAL.pdf.

The draft guidelines also state that electricity sales by SPPs to large business or commercial customers that sign PPAs for three years or more (termed “eligible customers” under the 2008 Electricity Act) do not require EWURA review.

2.3.4 FISCAL ARRANGEMENTS

The value-added tax (VAT) and custom duties on solar and wind technology products are zero. Other products and appliances are subject to a VAT of 20 percent and customs duties ranging from 20 to 30 percent.

2.4 OTHER RENEWABLE ENERGY PROMOTION

In addition to the institutional framework described in this chapter, there are many other initiatives fostering RE in Tanzania. Among these initiatives are programs by international donors, Tanzanian nongovernmental organizations (NGOs), and international development finance institutions.

2.4.1 INTERNATIONAL DONOR INITIATIVES

There have been a number of internationally funded projects in support of RE, especially solar energy. Working through the MEM, the Swedish government (through its development agency, SIDA) and the United Nations Development Programme (UNDP), supported by the Global Environment Facility (GEF), have implemented solar promotion programs in Tanzania, which have led to higher levels of awareness and increased capacity in the sector.

2.4.2 DEVELOPMENT FINANCE INSTITUTIONS

Development finance institutions are supporting RE in the East Africa region, including in Tanzania, by launching initiatives to facilitate debt financing. Most notable, the World Bank is offering the TEDAP credit line for small-scale RE to Tanzanian banks. In addition, the European Investment Bank (EIB) and International Finance Corporation (IFC) are currently preparing a clean energy lending facility for the region (starting in Kenya). This EIB-IFC initiative may include a credit guarantee facility. Furthermore, the Agence Française de Développement (AFD) is currently also considering structuring a credit line for RE and energy efficiency (EE) financing. To this end, the AFD hosted a seminar on RE/EE financing in November 2011 in Dar es Salaam.

2.4.3 TANZANIAN NGO INITIATIVES

A number of NGOs are involved in the promotion of RE in Tanzania. The Tanzania Renewable Energy Association (TAREA), for instance, is a national association bringing together actors and stakeholders to promote growth in the RE sector. TAREA’s activities include lobbying and advocacy for a sound sector environment, information dissemination, capacity building (training, magazines, workshops, solar days, and more), networking, and creating best practice standards for the industry.

The Tanzania Traditional Energy Development and Environment Organization (TaTEDO) is another key player in the sector. TaTEDO provides capacity building for sustainable energy services. It implements RE projects in rural areas with support from development partners including the European Union (EU), Norway, the Netherlands, and the United Nations. TaTEDO has several technology demonstration sites, which can be visited on request.



TAREA, the Tanzania Renewable Energy Association



Renewable energy NGO
TaTEDO

CHAPTER 3 Project Finance

Chapters 4 through 8 will discuss each of the most common RE technologies in turn and highlight both technical and financial aspects of RE projects. It should be noted, however, that financial analyses for projects using different technologies have a number of issues in common. For instance, in most cases, RE developers seek finance based on the forecasted *cash flows* of their project rather than on the fundamentals of their *balance sheets*. As a consequence, bankers need to be familiar with the concepts of project finance and the risks affecting RE projects.

This chapter therefore briefly discusses the fundamentals of project finance (section 3.1), the basic components of financial analysis (sections 3.2 through 3.5), common due diligence factors for RE projects (section 3.6), and key considerations in financial structuring (section 3.7).

3.1

FUNDAMENTALS OF PROJECT FINANCE

More often than not, RE projects cannot be financed based on their balance sheets because sufficient collateral to back up external debt requirements is missing. Therefore, banks willing to finance such projects need to engage in project finance. In general terms, project finance refers to the funding of a *specific* activity that is expected to generate *future* revenues. This differs from the more traditional balance sheet-focused approach, which funds corporate entities with a *broad* set of activities based on a track record of *past* revenues.

As a result, in project finance, a lender needs specific expertise to (i) verify whether the future revenue generation will indeed take place as projected and (ii) assess the associated risks (and mitigation factors). General characteristics of RE projects, which are explained in more detail throughout this chapter, include:

1. **Long and costly development periods.** RE project development is often long and costly due to the need to conduct feasibility studies, arrange legal permits, and contract EPC firms. For example, the cost of a hydropower feasibility study may range from US\$150,000 to US\$500,000, depending on the location, type of plant, and extent of the study.
2. **Limited project lifetime.** A project developer seeking external financing usually submits a financial plan for a defined time period of 10 to 15 years.
3. **Complex financial and contractual structures.** The typical RE project involves a range of actors including project developers, contractors, equipment suppliers, energy off-takers, and investors. Lenders should verify whether these contracts match each other; that is, are contractual obligations for equipment and supplies covered by long-term sales contracts?
4. **Special purpose vehicle (SPV) with a lack of collateral.** Given that projects are often structured in an SPV, the developer only has project assets and revenue contracts to offer as security. The lender therefore needs to assess the validity of the project developer's sales contracts and the project's ability to supply energy.
5. **Existence of ring-fenced cash flows.** RE projects may be defined in such a way that certain cash inflows, for example, cash flows from the sales of energy, can only be used for specific purposes according to a cash flow waterfall mechanism. Typically, a cash flow waterfall specifies that cash flows should service debt repayment first, and in sequence, equity disbursements. Thereafter, the cash flows can be used for other purposes. In all, this type of mechanism gives creditors a

better control over cash disbursements as opposed to a regular business. As a result, RE projects may support higher debt than regular business loans (see section 3.5.2 for further details).

6. **Lenders need to assess project risk.** Given the lack of collateral, lenders need to assess a project's debt-servicing capacity on the basis of cash flows and their volatility. To make this assessment, lenders need to understand the risks affecting project outcome. In other words, performing a sensitivity analysis is crucial (see section 3.5).
7. **Financed by a combination of debt and equity.** Traditional financial structuring of hydroelectric projects, for instance, combines senior debt from banks and similar lenders with equity from the sponsors and other investors. Senior debt usually represents 60–80 percent of the total investment plan. These percentages depend on the lenders' credit policies and risk preferences.

Compared to a typical business, a project is also much better defined in terms of its activities, costs, revenue contracts, and risks. Project finance therefore needs to conduct thorough due diligence on all of these factors. However, project finance can also support higher levels of debt compared to traditional balance sheet financing.

Lenders need to consider these characteristics when appraising an RE project. Generally an evaluation starts with a budget of all the costs involved in executing the project to determine, apart from the total cost of the project, the need for bank finance, equity contributions, and other financing sources. For instance, it is necessary to identify project implementation costs, operational costs for the plant, and the revenues that the plant will generate for a series of future years.

For the financial evaluation, one can use an investment plan, which should be backed by a detailed budget prepared by experts such as engineering firms, construction firms, contractors, and equipment suppliers. The next sections discuss project capital costs (section 3.2), project revenues (section 3.3), and project operating costs (section 3.4).

3.2 PROJECT CAPITAL COSTS

Sizeable RE projects such as hydroelectric plants, wind farms, or biogas generation projects require intensive capital investment for construction. Usually their development and implementation can be divided into two main stages: the preinvestment stage and the implementation/construction stage.

3.2.1 PREINVESTMENT STAGE

The preinvestment stage of a RE project can be both costly and lengthy. For instance, in-depth feasibility studies need to be conducted. Feasibility studies allow the project developer to confirm that a project is in principle viable, before performing more in-depth studies. Feasibility studies involve the completion of a series of specialized studies such as hydrology and geology studies, environmental impact assessments, engineering studies, project layout and design, project budgeting, construction plans and schedules, legal assessment, and the definition of equipment specification.

In addition to bearing the cost of feasibility studies, project sponsors also incur other project development-related costs such as transportation to the site, requesting and obtaining permits, legal opinions, salaries, and accounting and administrative expenses. Finally, during the preinvestment stage project developers typically cover (parts of) the cost of securing the land needed for the project.

Traditionally, project developers cover the cost of the preinvestment stage themselves because few other financing sources are available. But there are specialized investment companies, investment funds, NGOs, and multilateral and bilateral development bank programs that can cover part of the costs of these early stages of project development. An example of such a program is the REA's matching grants facility discussed in the previous chapter. Another way of financing the cost of the preinvestment stage is to sell equity participation to third parties.

The cost of the preinvestment stage differs due to a variety of factors, including the experience of the project developer and the complexity of the project. However, on

average, the costs of this stage represent 3–10 percent of the total investment cost of the project.

3.2.2 IMPLEMENTATION/CONSTRUCTION STAGE

The implementation/construction stage usually involves a period of several months to several years. The cost of the preinvestment stage is added to the cost of the implementation/construction stage to present the total investment plan of the project. In some cases, construction is funded through separate construction financing, which is then later replaced by project finance at lower interest rates.

The main items on the investment budget are:

- Land acquisition costs (including resettlement/compensation payments to previous users);
- Costs for equipment and civil constructions (hard costs, around 70 percent of total budget);
- Costs for studies, permits and other project development activities, bank and legal fees, and interest during construction (soft costs);
- Working capital (normally included as part of soft costs);
- Contingencies to cover construction cost overrun (set at around 10 percent of hard costs);
- If applicable, payments to reserve accounts (see section 3.5.2); and
- Water rights.⁷

Table 4 shows an example of the items typically appearing on a hydropower project investment plan.

⁷ In Tanzania, water resource management is taken care of by nine basin water boards under the Ministry of Water and Irrigation. The nine water basin boards, in accordance with the Water Supply and Sanitation Act of 2009, (available at <http://www.maji.go.tz/modules/documents/index.php?action=downloadfile&filename=THE%20WATER%20SUPPLY%20AND%20SANITATION%20ACT.pdf&directory=Water%20Legislation&>) take care of water right permits, which have to be applied for. For more information on these water boards, see <http://www.maji.go.tz/basins/index.php>.

Table 4: Typical Items on the Investment Plan of a Hydropower Project

Fixed assets	
Land	Land acquisition costs Resettlement/compensation costs
Civil engineering works	Intake Conduction channel Sand trap Forebay Penstock head gate Machinery chamber Water discharge channel Related works
Machinery and electromagnetic equipment	Penstock Turbine and regulator Generator and accessories Outgoing substation Transmission line Distribution substation
Installation and assembly of machinery and electromagnetic equipment	Installation of machinery and electromagnetic equipment and installation of grids and substations Vehicle hire Other
Intangible assets	
	Preinvestment study, technical advice, and supervision Interest during construction General expenditure Legal fees (including water permits)
Working capital	
	O&M costs
Other	
	Payment to reserve accounts Contingencies

Source: Authors' compilation.

3.3

PROJECT REVENUES

To undertake a financial evaluation of a project, it is necessary to first make financial projections concerning the *revenue-generating capacity* of the proposed project and to be able to relate these projections with the initial investment costs for project implementation. This section provides an overview of typical revenues inherent to RE projects across the board.

3.3.1

MAIN REVENUES

RE projects generally sell electrical energy to the government, a distribution company, a community, or a large-scale industrial consumer. In Tanzania, energy is typically sold to TANESCO's main and minigrids.

As in any business activity, a project's main revenue can be calculated by multiplying expected unit sales with the unit price. In the case of energy, only net energy generated (in kWh) can be sold. That is, the actual amount of energy that can be sold is less than gross energy generated due to losses in transformation, transport, and distribution.

Revenue forecasts can subsequently be obtained by multiplying the net value of energy (in kWh) generated by the applicable tariff (in Tanzanian shillings). The sales rates at

which SPPs supply energy to TANESCO are guided by the various SPPAs (see also chapter 2).

3.3.2 ADDITIONAL REVENUES

Retail sales

Some RE projects also sell energy to end consumers. Although retail sales tariffs have to be approved by the EWURA, it does not fix retail sales tariffs. As a result, retail sales tariffs may differ from one case to another. Therefore, to check estimated revenues from retail sales, it is important to look into project developers' sales contracts with prospective clients.⁸

Project residual value

In some instances, financial analysts may assign a residual value to heavy investments in long-term fixed assets. This residual value reflects the estimated market value of the assets by the end of the project. There are various methods for estimating the residual value. For instance, one could calculate expected future market value based on the wearing down of equipment. In any case, where financial projections are concerned, the residual value contributes to an internal rate of return (IRR).

It should be noted, however, that given the long lifespan of RE projects (that is, 10 years and beyond), a lot of factors influence this residual value. To be cautious, it is recommended to assume a residual value of zero in the base case financial analysis.

Carbon credits for the reduction of emissions

In addition to revenues from electricity sales, RE project business plans may also show sales revenues from carbon credits. A full explanation on the market for carbon finance is beyond the scope of this text. However, it is important for lenders to have a basic understanding on the market mechanism for carbon credits.

The market for carbon credits emerged from the international debate on the effects of climate change (that is, the Kyoto Protocol). Under these international treaties, institutes that reduce greenhouse gas emissions (GHGs) released into the atmosphere or remove GHGs from the atmosphere can earn carbon credits. These carbon credits, often referred to as certified emissions reductions (CERs), are transferable and have a monetary value. This value is due to the fact that other parties (for example, individuals, companies, or countries) purchase CERs to offset their excess GHGs. The market for CERs is overseen and regulated by the international Clean Development Mechanism's (CDM) Executive Board.

The various GHGs have different weights based on their climate effect. For example, a 1 ton reduction of methane is climatically equivalent to 21 tons of carbon dioxide (CO₂) reduced; it has a "CO₂ equivalency" of 21. Reducing 1 ton of methane can produce 21 CERs. The prices for CERs are currently in the range of €10 to €15.⁹

Tanzanian RE projects typically earn CERs and are therefore in a position to sell these to third parties. From a project point of view, this is an attractive way to boost cash flow. It should be noted, however, that the process is not without risk because of factors including:

- The process to register CERs at the CDM Executive Board is lengthy and costly.
- The calculation of anticipated emission reductions is complex and prone to differences in interpretation. As a result, there is a risk of overstating projected cash flow due to erroneously overstated emission reductions.
- The CER market depends largely on international policies, and currently the policy situation guiding this market for the period beyond 2012 is unclear.

For these reasons, there is an argument for appraising RE projects on the cash flow generation from energy sales alone. For example, European banks under most conditions would treat cash flow from CERs as an upside to regular cash flows only. That is, sales from CERs are typically not considered in the base case scenario. In this respect, however, it is worth noting that the REA and partners are currently planning to

⁸ The developments in retail tariffs and the EWURA's stand on them are discussed in more detail in section 2.3.3.

⁹ Carbon Positive, <http://www.carbonpositive.net/viewarticle.aspx?articleID=2353>.

implement two support mechanisms (that is, the PoA and the ESME grant) that would provide project developers timely access benefits from future carbon credits. As described in chapter 2, through the planned ESME project, eligible project developers can obtain a grant in the value of future revenues from CERs. Furthermore, through the PoA, the REA would take care of the administrative burden of dealing with CERs.

3.4 PROJECT OPERATING COSTS

This section provides an overview of typical operating costs inherent to RE projects across the board. For a discussion on costs of items related to a specific RE technology, refer to the relevant technology chapter.

3.4.1 OPERATION AND MAINTENANCE COSTS

O&M costs include expenditures related to the smooth functioning of the RE plant. In addition, O&M costs also include costs related to the programmed replacement of certain components and with the regular upkeep and lubrication of equipment. For these costs, payroll operators will need to be included as well as costs related to management. If there is an O&M contract, such costs are usually fixed.

The typical costs of an O&M contract are a function of the complexity of the project's RE technology. As a rough benchmark figure, for solar photovoltaic (SV), the costs of an O&M contract represent around 5 percent of energy sales income. For more complex RE technologies such as wind, hydro and biomass, the costs are usually higher.

RE projects selling on contract to isolated minigrids may occasionally need to purchase energy (at bulk tariffs) from TANESCO to be able to fulfill delivery contracts. This might occur if the project developer is facing (unexpected) difficulties generating sufficient energy output. Provisions for such energy purchases need to be factored into budgets.

In addition to payments for the O&M contract itself, the project developer may also be required to transfer funds to a *maintenance reserve account* to cover maintenance costs when due. See section 3.5.2 for a discussion on these and other reserve accounts.

As stated earlier, specific RE technologies may have specific types of costs. For biomass projects, for instance, the cost of feedstock is a major item. These and other project-specific costs are addressed in more details in the relevant technology chapters.

3.4.2 ADMINISTRATION COSTS AND INSURANCE

Administration costs typically include insurances and the salary for the team of people who will manage administrative procedures and related issues such as charging for energy sales, cash flow, bank and supplier relations, accountancy, surveillance, tax payments, other salaries, social benefits, and other tasks.

3.4.3 DEPRECIATION

Depreciation is an important area of expenditure and at the same time provides a fiscal shield. Starting with the fact that RE projects are capital-intensive, fixed-asset investments, considerable depreciation expenses are generated each year. The Tanzanian 2006 Income Tax Act¹⁰ specifies that both the diminishing value method and the straight line method may be used. The method and depreciation rate to apply depend on the class of fixed asset in question; Deloitte¹¹ provides an overview of the various asset classes and associated depreciation rates and methods in Tanzania.

3.4.4 DEBT SERVICE

Debt servicing corresponds to the payment of interest as well as the repayment of financing applied for to fund the project. For RE projects to be viable, project developers typically seek debt financing at single-digit rates. Most Tanzanian commercial banks, however, apply higher lending rates.

¹⁰ "Income Tax 2006," <http://www.tra.go.tz/documents/incometax1.pdf>.

¹¹ Deloitte, "Tax Matters: Insight into Tanzanian Taxation 2008," [http://www.deloitte.com/assets/Dcom-Kenya/Local%20Assets/Documents/TZ_Tax_Matters_Jun08\(2\).pdf](http://www.deloitte.com/assets/Dcom-Kenya/Local%20Assets/Documents/TZ_Tax_Matters_Jun08(2).pdf).

3.4.5 TAXATION

The last activity of considerable cost concerns payment of income tax. In Tanzania, the corporate income tax rate is 30 percent.

3.4.6 SUMMARY: COST OF ENERGY

Tables 5 and 6 provide a summary of capital and operational expenditures (CAPEX and OPEX, respectively) for the energy sources discussed in this manual. The tables draw from various sources and present a global picture based on experience in Western countries. Nevertheless, the information depicted here can be useful for comparison purposes.

Table 5 provides an overview of CAPEX per kilowatt of installed capacity and OPEX per kilowatt hour of generated energy. The column on the right is the levelized cost per kilowatt hour. Levelized cost includes all operational costs and amortized expenses of capital costs. The data compiled in the table show that SV is the most expensive technology, with a levelized cost of production of US\$0.30 per kilowatt hour. The high cost of SV is primarily due to high investment costs. Hydropower is the least expensive technology, thanks to low operational and average investment costs.

In sequence, table 6 shows the levelized cost of production per megawatt hour in a number of Western countries. The data compiled here yield a similar picture, with hydropower being the least expensive technology and SV the most expensive.

For Tanzania, there is not a sufficient amount of reliable data on levelized cost of energy production available. More research is available on SV, with some studies quoting a value of US\$0.25 to US\$0.5 per kilowatt hour for local minigrid SV systems in Tanzania.¹² Another study reports values of US\$0.66 to over US\$1.00 for SV systems in Kenya. The latter study also makes mentions of a levelized cost of production for wind energy of US\$0.23 to US\$0.29 per kilowatt hour.¹³

Table 5: CAPEX and OPEX of RE Technologies

Technology	CAPEX (US\$/kW)	OPEX (US¢/kWh)	Levelized cost of production (US¢/kWh)
Hydro	2,200	1	6
Biomass	2,000	2.6	10
Wind (onshore)	1,400	2	9
SV	5,000	1.3	30

Source: Altprofits, <http://www.altprofits.com/ref/eco/eco.html>.

Table 6: Levelized Cost of Energy Production across Countries (in thousands of TSh/MWh)

Technology	United States	United Kingdom	Australia	Germany
Hydro	134	n. a.	87	71–256
Biomass	176	145–291	140	156–234
Wind (onshore)	151	194–266	100	101–194
Solar PV	329	303–436	191	574–790

Source: Compiled by authors from various international studies.

Note: Converted to Tanzanian shillings at January 1, 2012, exchange rates.

¹² S. Szabó, K. Bódis, T. Huld, and M. Moner-Girona, "Energy Solutions in Rural Africa: Mapping Electrification Costs of Distributed Solar and Diesel Generation versus Grid Extension." In *Environmental Research Letters*, Volume 6 (2011), http://iopscience.iop.org/1748-9326/6/3/034002/pdf/1748-9326_6_3_034002.pdf.

¹³ U. Deichmann, C. Mesiner, S. Murray, and D. Wheeler, "The Economics of Renewable Energy Expansion in Rural Sub-Saharan Africa," World Bank Policy Research Working Paper 5193 (2010), http://www-wds.worldbank.org/servlet/WDSContentServer/WDSP/IB/2010/01/27/000158349_20100127142234/Rendered/PDF/WPS5193.pdf.

3.5

MODEL INTERPRETATION AND SENSITIVITY ANALYSIS

3.5.1

INTERNAL RATE OF RETURN AND DEBT SERVICE CAPACITY RATIO

Based on the estimated costs and revenues and forthcoming cash flows, a lender can estimate the project's **IRR and annual debt service capacity ratio (ADSCR)**.

- The **ADSCR** refers to a project's capacity to meet its debt service obligation (that is, interest and principal payments) from its operational cash flow. The ADSCR is calculated as: cash flow from operations/(interest plus principal payment).
- The **project IRR and the equity IRR** both relate to the project's rate of return. The project IRR is based on total debt and equity investments and subsequent cash flows from operations, that is, before debt service. The equity IRR, in turn, is based on equity investments only and subsequent annual total cash flows, that is, after debt service. For the equity investor, obviously, the equity IRR is the most relevant of the two.

The interpretation of the ADSCR and IRR is dependent on a number of factors including the sector, the environment, the timing of financing (that is, is financing applied for during the preparation, the construction, or the operation phase), and the lenders' and equity investors risk appetite. This manual uses a **rough rule of thumb** specifying that lenders should look for an ADSCR of at least 1.5. Equity providers, in turn, would look for an equity IRR in real terms in the range of 20–30 percent.¹⁴

Once the project is up and running, lenders should continue monitoring actual ADSCR levels. For instance, lenders may wish to predefine levels (for example, an ADSCR dropping below 1.2) at which they would require the project sponsor to explain poor performance.

3.5.2

ESCROW ACCOUNTS AND CASH FLOW WATERFALLS

In addition to certain ADSCR levels, lenders should also require project developers to establish escrow accounts (reserve accounts) at the bank. Over the lifetime of the project, sponsors would need to fund these accounts to provide security against cash flow problems. The sponsor can only withdraw funds from these accounts with the bank's consent.

Escrow and reserve accounts come in different forms. Common examples are:

- **Debt service reserve accounts (DSRAs)** contain sufficient cash to pay six month's worth of debt service (that is, principal plus interest payment). The project developer can either fund the account directly from the construction budget or gradually fill it from operating cash flow.
- **Maintenance reserve accounts (MRAs)** cover major maintenance works. Through this account, the project developer gradually builds up sufficient cash to cover maintenance works when due. In solar projects, for example, which have a project life of around 20 years, after 10 years, major maintenance work on inverters (or even replacement thereof) is due. This work can be financed from the MRA.

Except for payments to the DSRA, payments to reserve accounts are treated as a reduction from operating cash flow. As a consequence, payments to reserve accounts have a direct effect on a project's ADSCR. Payments to the DSRA in turn are ignored in the ADSCR calculation.

A tool often used in project finance is the **cash flow waterfall**, or "cascade." This tool is used to ensure the seniority of certain cash flows over others: that is, it specifies who is being paid first. For financiers, a project's cash flow waterfall is important because it specifies cash available for debt service and its seniority over other cash flows.

The main categories of a cash flow waterfall in order of occurrence are:

- OPEX;
- CAPEX;
- Taxes;

¹⁴ Note that the 20–30 percent range for equity IRR is based on experience with private independent power producers in Kenya.

- Debt services;
- Reserve accounts; and
- Equity disbursements.

The mechanism specifies that cash is only moved to the next category once the previous category has been paid. As a result, if cash flow is just sufficient to pay OPEX, CAPEX, tax and debt services, no cash can be distributed to reserve accounts and equity holders. In this manner, lenders have the first right to project cash flows. To further safeguard lenders' interests, cash flow waterfall mechanisms can be put under the control of a trust set up specifically for this purpose.

Box 1, using the cash flow waterfall mechanism, provides an illustrative example of a cash flow statement for a hydro project. For a more detailed discussion of cash flow projections for RE projects, refer to the chapters on hydropower and biomass.

Box 1: Sample Cash Flow Waterfall for a Hydropower Project (in millions of TSh)

	2011	2012	2013	(...)	2020
Revenues	-	1,464	1,523		2,004
Opex	(285)	(334)	(372)		(786)
Capex	(3,750)				
Tax	-	(109)	(108)		(229)
Cash flow before funding	(4,035)	1,021	1,043		988
Equity	1,322				
Loan	3,084				
Cash flow available for debt service	371	1,021	1,043		988
Principal payment	-	-	(433)		(78)
Interest payment	(371)	(392)	(416)		(375)
Cash flow available for reserves					
Payments to reserve accounts	-	(33)	(37)		(79)
Cash available to equity					
Dividends paid		(150)	(150)		(150)
Net cash flow	0	446	6		306

Source: Authors' illustration

3.5.3

SENSITIVITY ANALYSIS

Usually a financial model is prepared under a **base case scenario**, which takes into account project variables under the parameters considered most likely to occur. However, it is common to undertake a financial analysis for a project under pessimistic circumstances, where changes in the critical variables of the project are simulated to have lower revenues or higher costs to evaluate to what degree the project is able to sustain itself and maintain profitability. Such models are known as sensitivity analyses.

A **sensitivity analysis** can consider changes in one or several critical variables at the same time. One example for hydropower projects would be to suppose that water flow is 20 percent lower due to dryer years, while at the same time the capacity factor falls by 10 percent and the costs of O&M rise by 15 percent (for example, as a result of an inflationary spike). The lender should analyze to what extent the project developer would still be able to service project debt requirements when confronted with such events.

The RE technology chapters on hydropower and biomass present an example of a financial model accompanied by a sensitivity analysis. These analyses show how changes in key variables affect project's ADSCRs.

3.6 COMMON RISK/DUE DILIGENCE FACTORS

It should be noted that certain risks are common across the range of RE projects. This section lists a number of these common risks and/or factors that lenders should consider in the due diligence process of all RE projects. Risk factors affecting specific RE technologies are discussed in the relevant technology chapter.

3.6.1 MANAGEMENT RISK: PROJECT DEVELOPMENT AND ADMINISTRATION

The administration and prevention of risks that concern property owners, executors, borrowers, lenders, and investors are significantly linked to the experience that the developers have with the implementation of RE projects. This is a key issue affecting project viability at all stages.

Especially when project developers have inadequate experience, inherent risks in the development, implementation and management stages can be mitigated by contracting specialized services for project design and construction, such as consultancy businesses and engineering firms or by contracting an engineering, construction, and procurement (EPC) contractor (see section on contractual risks for more detail).

Furthermore, to the lender should understand the process that the project developer has followed to reach the feasibility stage. The lender or analyst should ensure that the developer has not been cutting corners or neglecting the completion of relevant assessments that could properly identify risks and help define mitigation measures.

To **mitigate** management risk, the lender should:

- Review with the sponsors the project development process and identify all key stakeholders involved;
- If the project development team presents weaknesses, propose alternatives for team strengthening such as attracting or contracting experienced firms or professionals; and
- Ensure that the sponsors are committed to project and have proven availability of total equity funds to be invested.

3.6.2 PERMITS, CONCESSIONS, AND RIGHTS

Obtaining all permits and rights to make a project possible usually requires a significant amount of time, and the project developer must be financially prepared to face this. To obtain the licenses or concessions to carry out power generation, the developer must make provisions for the period involved in processing and granting of rights. For instance, as per TEDAP operational guidelines, the RE project should comply with regulatory requirements of the EWURA (see also box 2).

Having all licenses in order is crucial for project viability. Without licenses, construction and operation, and thereby project repayment capacity, are at serious risk.

To **mitigate**, it is crucial for the lender to:

- Ensure that the project has complete control of all the land needed for complete development and operation;
- Be knowledgeable about the relevant licenses, concessions, and permits needed; and
- Confirm that the developer completed all relevant licenses, concessions, and permits before loan disbursement.

Box 2: Steps and Procedures for SPPs

In March 2011, the EWURA published guidelines for SPP development, specifying, among others, steps and prerequisites. The SPP should have the following in place:

- Land title or lease;
- Document demonstrating water rights (for hydropower projects);
- LOI showing that the DNO has no objections to interconnecting the proposed RE plan;
- Business registration, business licence, taxpayer ID, and VAT certificate;
- Building permits from district, municipal, or city council;
- Environmental and social clearances to ensure that the likely effects of new developments have been fully assessed;
- SPPA with the DNO;
- EWURA license—the applicant is required to pay a license application fee as approved by EWURA; and
- EWURA approval of retail tariff if it sells electricity directly to final customers.

Source: EWURA, “Electricity (Development of Small Power Projects) Guidelines,” <http://www.ewura.go.tz/pdf/SPPT/PROPOSED%20GUIDELINES/PROCESS%20GUIDELINES/Small%20Power%20Project%20Development%20Guidelines.pdf>.

3.6.3**LEGAL AND FISCAL FRAMEWORK**

Due to the long payback period of RE projects, a stable legal framework is needed for successful implementation. As discussed in chapter 2, in Tanzania, the legal framework is generally supportive of private sector investments in RE. The SPPA then takes on critical importance; as shown in the sensitivity analysis presented in chapters 4 and 5, (non-) adjustments in the SPPA rates significantly affect project viability.

To **mitigate**, lenders should consult a reputable law firm regarding the legal framework that supports the energy sector.

3.6.4**TECHNICAL RISKS**

There are technical risks in the project design and implementation stages, but sponsors are responsible for making every effort to anticipate these early during project design prior to construction. In the design stage, project developers need to conduct site research and feasibility studies to reliably estimate site potential and the size of construction works. A thorough review of the design and of the most important and/or expensive parts of the project can reduce overall risks. During budget decision making, any uncertainty in securing the price of components or keeping costs under control shall be reflected by including provisions for contingencies.

During project implementation and supply of equipment, there can be risks associated with the material quality, construction reliability, or the fabrication quality of equipment. Precise technical specifications in design and construction through material quality control and high factory standards can reduce risk. These contractual risks are detailed in the next section.

To **mitigate**, credit analysts reviewing RE projects should:

- Obtain an independent opinion on the project’s feasibility study;
- Ensure that the equipment to be purchased is tested and has proper warranty;
- Consider requesting that project construction and O&M be handled by a professional EPC contractor;

- Verify that all costs are properly budgeted for and understand who bears the responsibility of addressing civil works;
- Verify whether the project developer has obtained insurance policies covering both the construction and operation phase to insure against acts of God, equipment damages, and technical failures; and
- If possible, confirm that equipment suppliers and contractors have local presence to ensure timely support when needed.

3.6.5 PRODUCTION RISKS

To estimate future energy production levels, a feasibility study should be conducted by an experienced professional. For example, in hydropower projects, hydrology studies carried out during the design stage help forecast the water volumes to be used in the operation stage of the plant. However, there is a risk that these generation forecasts will not be met, which will affect the project's electricity and cash generation capacity and thereby the debt service repayment capacity. For the same reason, similar studies on wind and light conditions for wind and solar projects need to be carried out to forecast production levels.

Feasibility studies are of critical importance and should be conducted by experienced professionals. The RE technology chapters go into more detail on the need for these studies and associated production risks.

To **mitigate** these types of production (operational risks), lenders should:

- Obtain independent, professional reviews of feasibility studies;
- Assess project performance under more pessimistic generation scenarios, for example, a sudden reduction in water flow, wind speed, or feedstock availability; and
- Require developers to maintain a cash reserve equivalent to three or six months of debt service and O&M expenses to cover any cash shortfalls.

3.6.6 CONTRACTUAL AND COUNTERPARTY RISK

During implementation of construction contracts or equipment purchase, there are risks related to the construction contractors' and/or manufacturers' capacity to carry out the work, their experience, financial backing, and commitment.

Writing up contracts with engineer or consultant recommendations and employing tested procedures can reduce the risks of these contracts. Clear provisions in the contract itself to deal with litigation issues, as for example in arbitration procedures, will help resolve contractual problems. Furthermore—this is sometimes referred to as *counterparty risk*—the analyst should verify whether the contractor is sufficiently solvent to pay penalties when due.

For project operation, the most relevant contracts are the PPA and the O&M contracts. Often smaller projects are operated and managed by the same developer, in which case they lack an O&M contract.

Box 3: Engineering, Procurement, and Construction Contracts

A project developer can hire the services of one company to complete the entire process of design, specification, engineering, administration, and construction. This company would then turn over the completed, functioning project to the project owner, ready for operations. These contracts are called EPC contracts.

Companies that normally take on these responsibilities are consultant firms, hired specifically for completing the entire process, or a financial entity that takes on the risk of completing the project.

The total project amount in this kind of contract is fixed as a global sum upon signing the contract, making the (EPC) contractor responsible for all inherent risks in the process.

EPC contracts are common in BOT (build-operate-transfer) projects. BOT projects are executed by private companies and operated over contractually established timelines and then transferred to the public or private sector.

The advantages of EPC contracts for RE project developers are:

- The owner has the contractual certainty that the negotiated investment costs will not increase and that any risk of the project falling behind schedule will be covered and reimbursed by the EPC contractor;
- The owner does not need to worry about monitoring or supervising the construction process—the owner can demand quality compliance and functional guarantees upon conclusion; and
- The owner only has to have financial capacity, not necessarily technical capacity.

The disadvantages are:

- The costs of projects constructed under this modality are generally significantly higher than projects that do not cover the costs of all risks in advance;
- The success of this type of contract depends on the suitability, experience, and performance of the contractor;
- There are no EPC contractors for small works, and if these were eventually available, the differential cost in comparison to alternative modalities could make the project unfeasible;
- The corresponding contracts are complex and imply previous legal and technical consultancy costs of a significant magnitude in order for the negotiation with the contractor to be carried out in equal conditions; and
- The rigidity of the initial contracts could represent greater costs if modifications were to be introduced over the course of execution.

Source: Authors' compilation.

To **mitigate** for all types of contracts (EPC [box 3], PPA, O&M), the lender should:

- Obtain independent legal opinion on the contracts being signed by the project developers and identify potential conflicts and weaknesses (in case of an SPPA, such a review is less relevant);
- If deemed necessary, ask the project developer to obtain completion guarantees or other similar bank or corporate guarantees from constructors and suppliers;
- If possible, consult with other project developers who have dealt with the same suppliers to learn firsthand about their experience with those companies;
- Verify the effects of schedule and cost overruns on project cash flows by conducting a sensitivity analysis, especially if not arranged for by the contract; and
- Confirm that project developers can cover cost overruns with other funds as well as face unexpected delays during the construction period.

3.6.7 MARKET AND OFF-TAKE RISKS

Prevailing market conditions, such as demand and energy tariffs, can vary throughout the life of the project and affect financial and economic projections. The sponsors and financiers should therefore try to assess what the energy market's situation might be in the next 10 to 15 years, because this could have important impacts on energy rates and competition.

The market assessment shall include a comprehensive revision of the key stakeholders present in the market and their roles and competencies as well as of any plans to modify the energy market's structure and functioning. For example, relevant changes such as privatization of the generation or distribution sectors shall be assessed.

In Tanzania, as described in chapter 2, sales of energy to TANESCO's main grid are relatively predictable thanks to the SPPA for the two types of grids and the interconnection guidelines issued by the EWURA. Still, if possible, project developers could mitigate market risk by identifying alternative buyers.

However, banks may be concerned regarding the dominant role of TANESCO in the energy sector. Since TANESCO is the main off-taker of power from IPPs, concerns could arise regarding the willingness and ability of TANESCO to honor scheduled payment obligations. This concern is partially due to TANESCO's indebtedness. Obviously, this concern fuels project risk and may negatively impact bankers' evaluation of RE projects. On the other hand, given that TANESCO is a public enterprise, default is regarded unlikely.

Finally, also related to TANESCO's role as the main off-taker of energy, there is a risk that SPPs may not be able to deliver energy due to problems with TANESCO's main grid. That is, if the grid is malfunctioning, SPPs cannot off-load their produced energy continuously. On top of that, on the cost side, technical issues on the main grid directly affect SPPs' financials because they may frequently have to incur costs for back-up power. Finally, if SPPs get "tripped off" due to problems on the main grid, reconnection costs to restart energy delivery will be incurred.

To **mitigate** market risk, lenders should:

- Understand developments in energy tariffs. To be on the safe side, lenders could appraise RE projects based on tariffs as set the year the SPPA is signed, not factoring in future tariff increases to mitigate risks from delayed or otherwise disappointing EWURA tariff adjustments.
- If possible, ask project developers to reduce dependence on a single energy buyer by identifying alternative buyers.
- Monitor the effect of additional costs from trip-offs and back-up power purchases on project debt service capacity ratio (DSCR).
- Check the financial standing of dominant energy off-takers.

3.6.8 ENVIRONMENTAL AND SOCIAL RISKS

To qualify for financing under the TEDAP credit line, the RE project should comply with the credit line's Environmental and Social Management Framework (ESMF). In principle, the REA verifies projects' compliance with this framework. Lenders should confirm that the REA has indeed confirmed compliance.

According to TEDAP operational guidelines, the following World Bank policies are particularly relevant:

- **Environmental Assessment.** This policy requires an environmental impact assessment (EIA) of projects/programs to help ensure that they are environmentally sound and sustainable.
- **Physical Cultural Resources.** Cultural property includes sites having archaeological (prehistoric), paleontological, historical, religious, and unique natural values. Projects that will damage such property should be avoided.
- **Involuntary Resettlement.** This policy would be triggered when a project requires appropriation of land and other assets. In such cases, the sponsor will have to follow

the Resettlement Policy Framework (RPF), which sets guidelines for resettlement and compensation action plans.

- **Safety of Dams.** For projects that involve the use of existing dams, the sponsor is required to arrange for independent dam specialists to inspect and evaluate the dam's safety status and the owner's O&M procedures.
- **Projects on International Waters.** This policy applies when potential international water rights may be an issue.

From the lender's perspective, environmental and social risks could be **mitigated** by:

- Verifying that the REA has approved project compliance with the ESMF;
- Conditioning loan disbursement to full compliance with prevailing regulations;
- Demanding an independent assessment of the project developer's EIA;
- Including mitigation measures that the project developers assume with relevant authorities in the loan agreement so that they become contractual obligations; and
- Visit sites to meet community leaders and identify any areas of conflict or concern that could eventually lead to future problems for the project.

3.6.9

COUNTRY RISK: MACROECONOMIC AND POLITICAL

Country risk is generally understood in its broadest sense as combined political, financial and economic risks, with compounded results.

For example, RE project developers face a series of financial risks related to macroeconomic factors. These include changes in inflation rates, exchange rates, and interest rates. Suppliers' contracts could be stated in U.S. dollars and energy sales quoted in Tanzanian shillings, leaving open the risk for exchange rate volatility to have a real impact on project cash flow. Obviously the same is true for inflationary pressure. The sensitivity analyses presented in chapters 4 and 5 show that inflationary pressure and Tanzanian shilling depreciation indeed have a significant impact on project cash flow. In a similar vein, interest rate volatility may affect project cash flow if the debt contract does not specify a fixed interest rate.

To **mitigate** these types of risk, the lender could:

- Check project DSCR's sensitivity to changes in inflation and exchange rates (see chapters 4 and 5 for an example);
- If possible, request comprehensive insurance policies to cover political and country risk;
- Provide the loan in the same currency as the one used to invoice sales of electricity, which in Tanzania is the Tanzanian shilling.

Figure 1 shows the development in a number of these macroeconomic variables for Tanzania: inflation rates, lending rates, risk premiums,¹⁵ and the Tanzanian shilling/U.S. dollar exchange rate.

¹⁵ Risk premium on lending is the interest rate charged by banks on loans to prime private sector customers minus the "risk free" treasury bill interest rate at which short-term government securities are issued or traded in the market.

Figure 1: Tanzania Macroeconomic Indicators (2001 –11)
Inflation rates, lending rates, and risk premiums over the period 2001 – 11
(in %)

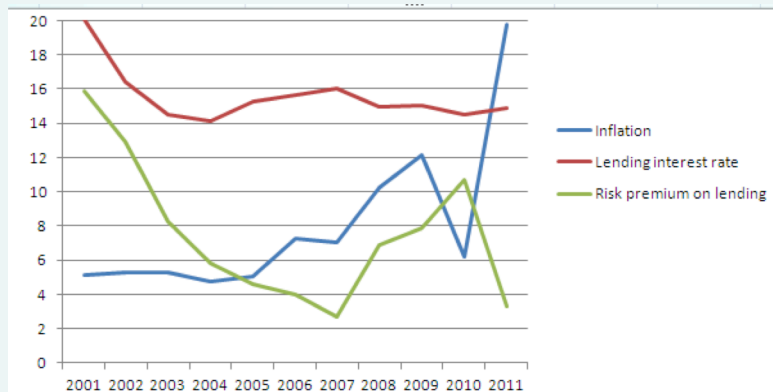

Exchange rate developments over the period 2001 –011 (TSh/US\$)

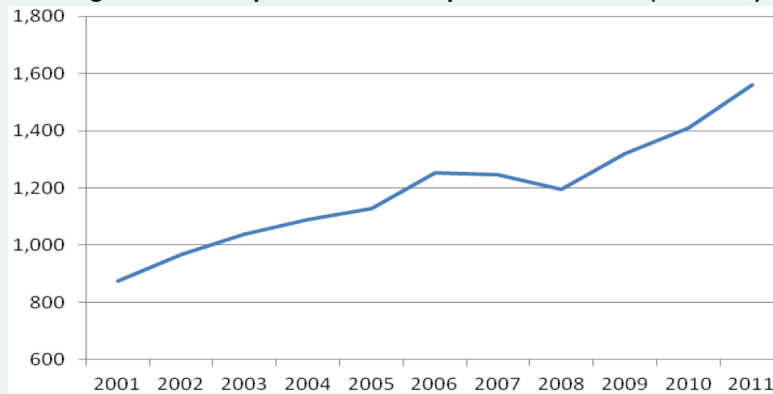

Sources: World Bank, Bank of Tanzania, and OANDA.com.

Note: 2011 lending rate and risk premium are per October 2011.

3.6.10

SUMMARY: RISK FACTORS AND MAIN MITIGATION MEASURES FOR FINANCIERS

As shown in this manual, there are wide-ranging factors affecting RE project viability, and as stated previously, most of these factors affect all RE technologies. Table 7 lists the most important risk categories and their effects on project viability in terms of low, medium, and high impact. In addition, the table contains a number of mitigation measures that could be implemented by financiers to address these risks. The table is included for summary purposes only, and should not be read in isolation or as a substitution for this section.

Table 7: Summary of Risk Categories and Main Mitigation Measures for Lenders

Risk category	Main mitigation measures	Impact of risk on project viability			
		Hydro	Biomass	Solar	Wind
Management	<ul style="list-style-type: none"> Determine stakeholders' capacities Propose alternatives for team strengthening Require equity commitments 	High	High	High	High
Permits, concessions, and rights	<ul style="list-style-type: none"> Confirm that the developer obtained all relevant licenses, concessions, and permits before loan disbursement 	Medium	Medium	Medium	Medium
Legal	<ul style="list-style-type: none"> Obtain advice from legal experts on legal framework 	Low	Low	Low	Low
Technical	<ul style="list-style-type: none"> Ensure that the equipment to be purchased is tested and has proper warranty and insurance Consider requesting that project construction and O&M be handled by a professional EPC contractor 	Medium	Medium	Medium	Medium
Production (technology specific)	<ul style="list-style-type: none"> Check DSCR sensitivity to changes in: water flow, cost, feedstock availability, radiation, and wind Require sponsors to maintain a DSCR reserve account Check assumptions in and quality of feasibility study 	High	High	Medium	High
Contract	<ul style="list-style-type: none"> Check DSCR sensitivity to cost overruns and construction delays Obtain independent legal opinion on the legal contracts being signed by the project developers Confirm that project developers can cover cost overruns and unexpected delays from other funds 	High	High	High	High
Market and off-take	<ul style="list-style-type: none"> Check DSCR sensitivity to stagnation in SPPA rates If possible, ask project developers to reduce dependence on single energy buyer by identifying alternative buyers Check the financial standing of dominant energy off-takers Monitor the effect of additional costs from trip-offs and back-up power purchases on project DSCR 	High	High	High	High
Environmental and social	<ul style="list-style-type: none"> Verify that the REA has confirmed project's compliance with the ESMF Condition loan disbursement to full compliance with prevailing regulations Demand an independent assessment of project's EIA 	Low	Low	Low	Low
Country risk (macroeconomic and political)	<ul style="list-style-type: none"> Check DSCR's sensitivity to changes in inflation and exchange rates If possible, request comprehensive insurance to cover political risk 	High	High	High	High

Source: Authors' compilation.

3.7

FINANCING STRUCTURES IN PROJECT FINANCE

As stated in the beginning of this chapter, project finance typically involves a combination of debt and equity finance. Senior debt usually represents 60 to 80 percent of the total investment plan. Obviously, the mix of debt and equity (debt-equity ratio) has a direct impact on the project's DSCR and IRR. That is, a project with a higher equity investment will, all else being equal, have a lower equity IRR than a project with a lower equity investment. Sponsors may therefore wish to limit their equity investments so as to increase returns on equity. Lenders, on the other hand, would like to see projects have sufficiently secure cash flows to cover debt service.

In theory, a project's cash flow could be sufficiently secure to allow for 100 percent debt financing. However, from a commitment point of view, lenders prefer project developers to bear part of the risk by contributing some equity. In fact, a sponsor's willingness to commit equity for a prolonged period could be a good indicator of the project's health.

Directly related to the financial structure of project finance is the issue of priority of cash flows. Equity investors, for instance, are only entitled to cash distributions once all other claims (such as operating costs, interest, and principal payments) have been met. Further, even among equity investors, cash distribution priorities exist, with preferred equity holders having priority over common equity holders.

3.8

FURTHER INFORMATION

Sorge, M. 2004. "The Nature of Credit Risk in Project Finance." *BIS Quarterly Review* December, http://www.bis.org/publ/qtrpdf/r_qt0412h.pdf.

Yescombe, E. R. 2002. *Principles of Project Finance*. San Diego: Academic Press.

CHAPTER 4 Hydropower

This chapter provides the basic technical and financial model as well as key due diligence factors for “run-of-the-river” type hydro projects in Tanzania. The elements presented in this chapter can, in conjunction with the information presented in the general chapter on project finance, be used as reference material when appraising loan applications for small hydro projects.

4.1 THE BASICS OF HYDROPOWER

4.1.1 METHODS OF HYDROPOWER

Hydropower technology uses a hydraulic installation that transforms the force of moving water into mechanical energy shaft power and then into electrical energy. There are basically two ways to harness power from moving water:

- Run-of-river: Divert the course of the water, leading it with a slight directed slope to an adequate place, where it will descend toward the turbine situated on the riverbank downstream from the intake.
- Dams: Construct a dam in an adequate place, in a natural water course, where the level of the water stored in the dam will increase until it fills to the necessary amount. In this case, the power house can be located at the foot of the dam.

A combination of the above two methods can also be used: a dam to capture and store water, and a conduit to direct the water to an adequate site where a fall can be generated. In Tanzania, there is large potential for run-of-river systems that do not require a dam. Section 4.2 provides additional technical specifications for run-of-river systems.

4.1.2 CLASSIFICATION OF HYDROPOWER SYSTEMS

There are different methods for categorizing hydropower schemes. One method categorizes these schemes according to height differences between the water source and outflow (referred to as “head”). Low-head plants are less than 15 meters high, medium-head plants are between 15 and 50 meters high, and high-fall plants are higher than 50 meters. Another classification of hydropower schemes is based on installed capacity; distinguishing among full-scale, small, micro, and pico hydropower (table 8).

Table 8: Classification of Hydro Systems by Installed Capacity

Classification	Installed capacity
Full-scale hydro	>10 MW
Small hydro	100 kW – 10 MW
Micro and pico hydro	<100 kW

Source: Authors' compilation.

4.1.3 MEASUREMENTS: POTENTIAL CAPACITY AND ACTUAL ENERGY GENERATED

In general, hydroelectric plants can generate revenues from two principal sources: the sale of energy and the sale of capacity. However, in Tanzania, as per the SPPA, only electrical energy can be sold.

Installed capacity (measured in kW, MW, or GW)

The installed capacity (or maximum potential power) of a hydroelectric plant is a linear function of:

- Flow—variable, the volume of water passing per second, measured in cubic meters (m³)/second;
- Head—fixed, measured in meters (m);¹⁶
- Gravity—fixed at = 9.81 m/second²; and
- An efficiency factor reflecting conversion losses in energy generation, a value between 0 and 1.

The best energy technologies can be 80 to 90 percent efficient. For small systems, an efficiency factor of 50 percent can be used.

Installed capacity can be calculated in the following formula: $P \text{ (kW)} = \text{flow (m}^3/\text{s)} \times \text{head (meters)} \times \text{gravity (m/s}^2) \times \text{efficiency}$. *Example:* A small turbine generator operating at a head of 10 meters with a water flow of 21 m³/second has a capacity of approximately: $21 \times 10 \times 9.81 \times 0.5 = 1,030 \text{ kW}$.

Energy generated (measured in kWh, MWh, or GWh)

The actual annual energy generated by a hydroelectric plant depends on, among other factors, the time the turbine is used. If a turbine with a capacity of 10 MW was used continuously, an annual energy output of $10 \text{ MW} \times 8,760 \text{ hours} = 87,600 \text{ MWh}$ could be realized.

However, in reality, a turbine will rarely be used continuously. Therefore, potential energy output is usually estimated using a capacity factor. In Tanzania, a capacity factor of 40 to 50 percent is common for hydro plants.

A plant's capacity factor can be calculated by dividing actual energy generated over the amount of power that is available if the turbine were to be used continuously. *Example:* A 10 MW turbine generator has a capacity factor of 50 percent. Expected energy output can be estimated at $10 \text{ MW} \times 8,760 \text{ hours} \times 50 \text{ percent} = 43.8 \text{ GWh}$.

Box 4: Application: The ABC Hydropower Project

The business plan of the ABC "run-of-the-river" hydropower project shows the following technical specifications: gross head 63 m, water flow 3.4 m³/s, installed capacity 1.5 MW, and expected energy generation 6,450 MWh per year.

Questions:

1. What efficiency factor did the project developers assume?
2. What capacity factor did the project developers assume?

Answer:

1. Capacity (1,500) = flow (3.4) × head (63) × gravity (9.81) × efficiency factor
Efficiency factor = $1,500 / (3.4 \times 63 \times 9.81) = 0.71$
2. Capacity factor = expected energy generation / maximum energy generation
Capacity factor = $6,450 / (1.5 \times 8,740) = 0.49$

Source: Authors' illustration

4.2**TECHNICAL SPECIFICATIONS FOR RUN-OF-RIVER HYDROPOWER****4.2.1****BASIC COMPONENTS**

Run-of-river hydro projects use the natural downward flow of rivers and turbine generators to capture the kinetic energy carried by water. Typically water is taken from

¹⁶ The head is the vertical height, in meters, from the turbine up to the point where the water enters the intake pipe or penstock. See section 4.2 for a brief explanation on these technical terms.

the river at a high point and fed down a pipe to a lower point, where it emerges through a turbine generator and re-enters the river.

Figure 2 shows the main components of a run-of-the-river hydro scheme. This type of scheme diverts river water by a *weir* through an opening in the river side (the *intake*). The weir diverts the water into a *canal*. The canal contains a settling basin that is used to remove sand particles and other sediments from the water. The water is then channeled along the canal before arriving at a *forebay*, which allows the last particles to settle down. Thereafter, water flows via a *penstock* (a pressurized pipeline) into the *powerhouse*. In the powerhouse, the moving water rotates a *turbine*, which spins a shaft. The motion of the shaft provides rotational energy that is used to start a generator to transform the rotational energy into electricity. Finally, electricity has to be transmitted to the grid through *transmission lines*.

The eventual energy output will be less than the available power due to efficiency losses in the turbine, the generator, and the transmission system. Transmission losses, for instance, depend on the distance travelled and the characteristics of the transformation equipment and transmission lines. For these and other reasons, an efficiency factor (see previous section) is used when calculating installed capacity.

Figure 2: Basic Components of a Run-of-the-River Hydro Scheme

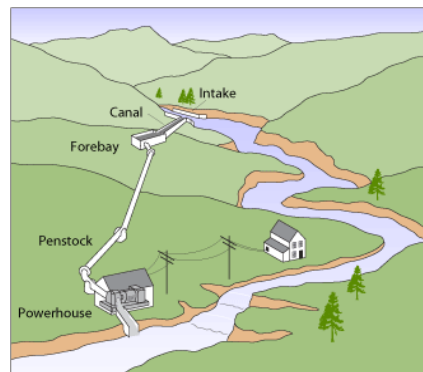

Source: <http://www.energysavers.gov>

4.2.2 DESIGN CONSIDERATIONS

As described above, the power and production capacity of a hydropower station is a direct function of the height of the available drop (head) and the flow. As a consequence, choosing the head and flow design is of great importance in the design of a power station. During the design phase, decisions on flow and head should maximize production capacity.

Given these and other considerations, a feasibility study must be conducted to locate the best site and to help optimize site design. For such a study, having reliable hydrology data—for example, data on upstream and downstream river flows and precipitation patterns—is critical.

4.3 HYDROPOWER OPPORTUNITIES IN TANZANIA

In Tanzania, hydropower development opportunities are abundant. Statistics estimate that Tanzania has estimated hydropower potential of 4.5–4.7 GW, yet only around 561 MW have been developed. Table 9 shows the installed capacity and generated electricity of TANESCO's main stations in 2007.

Table 9: TANESCO, Installed Capacity and Generated Energy in 2007

Station	Installed capacity (MW)	Energy production (GWh)	Load factor (%)
Kidatu	204	964	54
Kihansi	180	662	42
Mtera	80	363	52
New Pangani Falls	68	323	54
Hale	21	88	48
Nyumba ya Mungu	8	35	50
Total	561	2,435	50

Source: TANESCO (2007).

Given that only around 561 MW have been developed, there are opportunities for both full-scale and small hydro projects:

Potential for full-scale hydro projects (capacity > 10 MW). TANESCO is aware of the need to develop large-scale hydro projects. TANESCO is currently seeking investment partners to develop 10 large-scale projects with a cumulative capacity of over 3,000 MW.¹⁷

Potential for small hydro projects (capacity: 100 kW to 10 MW). Regarding smaller hydro projects, previous studies have shown that there is a strong potential. For instance, although it is estimated that 100 GWh per year could be produced from such small systems, only around 32 GWh per year were produced during the mid 2000s.¹⁸

Regarding smaller projects, as part of its Rural Electrification Master Plan (2005), TANESCO identified five small hydropower opportunities that it plans to develop as pilot projects to be leased to private operators. Developing these five small-scale projects would require an investment of around US\$80 million.

In addition, the MEM has identified over 100 sites for potential small hydropower generation that are of little interest to TANESCO. These small hydro opportunities are being marketed by the REA to prospective SPPs to be developed as grid-connected or isolated (off-grid) minigrid systems. The REA has compiled a pipeline of small hydropower projects. This pipeline is composed of projects at various stages of development. Table 10 contains examples of projects in the pipeline.

Table 10: Examples of Hydropower Projects in the REA Pipeline

Project name	Installed capacity (MW)	Energy production (GW per annum)	Load factor (%)	Investment cost (US US\$ million)	Investment cost per kW (US\$)
Kilocho	10	35	40	25.5	2,550
Mufindi Tea SHP	4	28	80	3.1	775
Kitonga SHP	10	35	40	21.0	2,100
Suma SHP	1.5	6.6	50	4.2	2,800

Source: REA pipeline.

Note: Investments reflect total project cost minus distribution cost. SHP = small hydropower project.

4.4

KEY CONSIDERATIONS FOR FINANCING HYDROPOWER PROJECTS

For a lender, the main hydro-specific issues to consider during project review are:

- Capacity factor and water flow;
- Investments—capital cost overruns and construction delays; and
- Legal issues and water rights.

In addition to these hydropower-specific considerations, other key factors inherent in project finance require attention as well. Those general factors are addressed in chapter 3 (Project Finance).

4.4.1

CAPACITY FACTOR, WATER FLOW, AND FLOW DURATION CURVES

To establish energy production levels and the installed plant capacity, a hydrology study is carried out in the design stage that will help forecast water volumes for the operation stage. There is a risk that these generation forecasts will not be met, which in turn will affect the project's electricity and cash generation capacity, and therefore project debt service repayment capacity.

Adequate knowledge of river courses and their variations is fundamental not only for power and energy calculations, but also for the project's economy. Basic river course knowledge is also necessary for designing the dimensions of the works and ensuring functionality and stability. For these reasons, all efforts should be made to ensure that the hydrology study is conducted by a professional with the appropriate expertise. This includes studies conducted during the installation of measurement points in early stages of the project to determine watersheds' hydroelectric potential.

¹⁷ http://www.tanESCO.co.tz/index.php?Option=com_content&view=article&id=99&Itemid=252.

¹⁸ Among others: Helio International (2005), Energy and Sustainable Development in Tanzania: <http://www.helio-international.org/uploads/Tanzania-EN.pdf>. The more recent EWURA 2009 annual report confirms TANESCO's 561 MW hydropower capacity.

Accurate measurement can help establish a **water flow duration curve**. The latter is an accumulative frequency curve that shows the percentage of time in which the values of historical flows have been met or surpassed in a determined registry period.

Ideally, one should assess water flow data for a period of 10 to 30 years to have statistically reliable predications of water flows throughout the lifespan of the project. Unfortunately, water flow data do not exist for such long periods. As a result, developers may only be able to develop hydrological models based upon precipitation data for the catchment area.

Again, the hydrology study must be conducted by experienced professionals to ensure precise water volume measurements over sufficiently long periods of time. Often there are not sufficient historical data on water flow. When this is the case, it is usually better to build data by installing water level scales and water flow measuring devices in the river. At least one year of data should be obtained so that the measurements can be correlated with historic rain fall data in the project's water basin.¹⁹ In addition, obtained data should also be correlated with historic flow records in nearby gauged rivers (if information is available).

When reviewing a project proposal, the lender should check the reliability of estimated energy production versus installed capacity (see earlier example of ABC hydropower project). It is worth noting that the majority of project proposals in the current REA pipeline have capacity factors between 40 and 50 percent. However, higher capacity factors may also be observed. It is also important to keep in mind that the "capacity factor" or capacity usage of a hydroelectric plant varies according to the season. In dry months, for instance, volumes are generally lower than in the wet season. Finally, capacity factors should not be interpreted as a fact since they are also dependent upon project developers' return optimization strategies.

Lenders, when checking volume flows and capacity factors, should confirm:

- The completeness of the hydrology study;
- The reputation and expertise of the expert/firm who carried out the study; and
- The generation forecast methodology.

Project developers, on the other hand, can mitigate the risk of (the effects of) having unreliable water flow data in a number of ways. Lenders can check to what extent project developers have employed these kinds of precautionary measures:

- Obtain independent hydrology study revision;
- Assess project's performance under pessimistic generation scenarios;
- Create a cash reserve to deal with extremely dry months or years (using escrow accounts);
- Reconfirm water use upstream and downstream from the project site; and
- Ensure that adequate water basin protection programs exist.

4.4.2

INVESTMENT COSTS AND CAPITAL COSTS OVERRUNS

In general, a hydroelectric project faces more substantial risks during the construction and preoperating phase than during operation. During construction, one problem on one piece of the scheme can wash away all the other contractors' good work. Therefore, it is imperative that the lender perform a thorough and comprehensive evaluation of all aspects during the design stage of a hydroelectric project.

¹⁹ For a discussion on methods of obtaining water flow duration curves when lacking long-term local data, see: P. Copestake and A. Young, "How Much Water Can a River Give? Uncertainty and the Flow Duration Curve." Proceedings of BHS 10th National Symposium (2008), http://www.google.nl/url?sa=t&rct=j&q=water%20flow%20duration%20curve&source=web&cd=3&ved=0CD0QFjAC&url=http%3A%2F%2Fwww.sepa.org.uk%2Fscience_and_research%2Fdata_and_reports%2Fidoc.ashx%3Fdocid%3D2e619b9c-8ab0-461d-8fec-d3c8c9a6fb38%26version%3D-1&ei=wXceT-r5JcKc-waYmLU-&usq=AFQjCNGQ2TezzKFS_BJh4enx3nC-YCDZSQ&sig2=xphVAm41afWY03PHLuI_q.

The investment costs of a hydroelectric plant normally are between US\$1,500 to US\$2,500 per kW of the installed capacity. For the projects in the REA pipeline in Tanzania, the observed range is broader: US\$1,250 to US\$11,500 per kW. The magnitude of investments costs depends on a range of variables such as:

- The plant's design head and volume flow (hydrology and topography);
- The size of civil engineering works;
- Regulatory requirements and taxes;
- Access to the site;
- Distances of the energy cables connecting with the market;
- Source of equipment and basic materials; and
- Land costs.

When reviewing investments costs, as in any RE project, it is essential to review the cost estimated by the EPC contractor. Furthermore, to mitigate capital costs overruns and construction delays, the contract between the project developer and the EPC contractor should contain provisions dealing with cost and schedule overruns. Ideally, the EPC contractor guarantees the entire set up, including turbines.

4.4.3 LEGAL ISSUES AND WATER RIGHTS

As in all RE projects, a hydropower project developer needs to comply with regulations (see also chapter 3). An additional difficulty in the case of hydropower projects is related to competition arising from other uses of water, for example irrigation. Project developers and lenders need to ascertain whether such issues exist, and if so, that they are resolved. In this respect, the EWURA guidelines specify that:

It is important that the SPP developer be able to demonstrate that he/she is the legal holder of rights to sufficient resources to make the project viable. The required documents include water rights permission issued by the appropriate authority.

Project developers and lenders should ensure that all environmental impacts are thoroughly addressed, including impacts on aquatic ecosystems, floodplain agriculture, and community use of water. Furthermore, people affected by project impacts should share in project benefits.²⁰

4.5 THE FINANCIALS OF HYDROPOWER

This section provides a financial model of a typical hydropower project. It should be noted that when describing the financial model, only the costs and revenues *specific* to hydropower projects are included. For a description of the other types of costs and revenues, refer to the chapter on project finance.

This section provides an example of the financial model of an imaginary hydropower project, "Sawa Hydro" (boxes 5, 6, and 7). It should be noted that this example has been kept straightforward and is primarily for illustrative purposes.

4.5.1 THE FINANCIAL MODEL

The financial model of a hydroelectric plant does not need to be unusually complex or sophisticated. It is, however, extremely important to have as much support as possible to define the critical variables that influence financial outcomes.

Revenues

The revenues of a hydroelectric power plant come from:

- Energy sales to TANESCO—tariffs governed by the SPPAs for the TANESCO main grid and for the existing isolated TANESCO grids (see section 2.3 for a discussion on the two SPPAs);
- Retail sales, at rates specified in contracts, not standardized in a SPPA;
- Project residual value, although this is often not considered in the base case scenario; and

²⁰ See section 3.6.8 for further details on environmental and social issues (including a reference to the ESMF and RPF).

- Carbon credits, although these are often not considered in the base case scenario.

There are also a number of revenue-related considerations that set hydro projects apart from other RE projects. First, as discussed above, project income is also a function of a plant's water flow and capacity factor. A lower flow or factor will obviously have a negative effect on sales revenues.

Box 5: Example—Sawa Hydro Project Revenues

The 1.9 MW Sawa hydro project (head 46 meters, flow 6 m³/second, efficiency 70 percent) has an expected capacity factor of 70 percent. As such, the project's expected annual energy generation is: energy generated = $46 \times 6 \times .7 \times 9.81 \times .7 \times 8,760 = 11.6$ GWh.

The project will run for 10 years (2011–20) and start generating and selling energy in the second year (2012). The first year (2011) is a construction year. Throughout the project, energy will be sold to TANESCO's main grid. The project does not have other sources of revenue. The developer assumes that the main grid SPPT will be adjusted annually by 4 percent. Therefore, annual sales can be calculated as follows:

- Sales 2012 = $11,621,931 \times 121.13 \times (1.04) =$ TSh 1,464 million.
- Sales 2013 = $11,621,931 \times 121.13 \times (1.04)^2 =$ TSh 1,523 million.

Source: Authors' illustration.

Note: This example uses the base SPPT for the calendar year. In reality, however, the rate is dependent upon the season (wet versus dry season), as discussed in chapter 2.

Capital costs

Internationally, investment costs for a hydro plant range from US\$1,500 to US\$2,500 per kilowatt of installed capacity. For the projects in the REA pipeline in Tanzania, the observed range is broader: US\$1,250 to US\$11,500 per kilowatt. Typical capital costs for small hydropower plants include the following items:

- Land acquisition cost;
- Cost of civil works;
- Cost of hydromechanical and electromechanical equipment;
- Cost of grid connection; and
- Engineering and project management costs.

The costs of civil works are largely site specific. For instance, on high head sites, the major cost will most likely be the penstock. On low head sites, water intake, screens, and channel will probably constitute the major cost items. In a similar vein, machinery costs for high head schemes are generally lower than for low head schemes of similar power. This is due to the fact that high head machines have to pass less water than low head machines for the same power output and are therefore smaller. Furthermore, the cost of penstocks has a significant impact on the overall cost of the scheme. Therefore, penstocks should be kept as short as possible.

Box 6: Example—Sawa Hydro Project Capital Costs

The Sawa project requires a total investment of US\$2.9 million or US\$1,550 per installed kilowatt. Of this amount, US\$2.5 million is for the purchase of fixed assets (depreciated straight line over 10 years, no residual value), the remaining US\$437,000 is for “soft” investments. All investments are made in project year one (2011). The table below provides a specification (all amounts converted to TSh millions; TSh/US\$ exchange rate = 1,500).

Fixed assets	Amount	Soft investments	Amount
Land & preparation	312	Feasibility studies	150
Civil structures	885	Project development	75
Electromechanical equipment	1,015.5	Interest during construction	371
Cost of grid connection	565.5	Legal fees	60
Construction & office equipment	597		
Contingencies	375		
<i>Source: Authors' illustration.</i>			
Total fixed assets	3,750	Total other investments	656

Box 7: Example—Sawa Hydro Project Financing Structure

To finance the US\$2.9 million investment cost, the project sponsors contribute 30 percent equity and demand 70 percent debt finance. Subsequently, the 12 percent loan amounts to US\$2,055,900. There is a grace period of two years, after which the loan is paid back in eight equal annual installments (all amounts in thousands of U.S. dollars).

	2011	2012	2013	2014	2015	2016	2017	2018	2019	2020
Balance	2,056	2,056	2,056	1,799	1,542	1,285	1,028	771	514	257
Principal			257	257	257	257	257	257	257	257
Interest	247	247	247	216	185	154	123	93	62	31

For the purposes of Sawa Hydro Project's cash flow, however, the debt service payments have to be converted to Tanzanian shillings. For the conversion, the project developer assumes an annual 6 percent depreciation of the Tanzanian shilling to the U.S. dollar (starting from TSh/US\$1,500 in 2011). Applying this assumption, the annual installments (expressed in TSh millions) are as follows:

	2011	2012	2013	2014	2015	2016	2017	2018	2019	2020
Principal			433	459	487	516	547	580	614	651
Interest	370	392	416	386	350	310	262	209	147	78

Source: Authors' illustration.

Operating costs

A hydropower plant's cost structure follows the general cost structure of RE projects outlined in chapter 3. The most relevant operating costs are: O&M, administration, depreciation, taxation, and financial charges. Experience shows that O&M costs for small hydro turbines are usually low. Also, a hydro plant's operating expenses tend to be relatively fixed because:

- Maintenance costs can be projected using pro forma statements of technology suppliers; and
- A fixed O&M contract (for example, as a percentage of energy sales income) can reduce volatility of expenses—usually the cost of an O&M is no more than 5 percent of energy sales income.

On the other hand, while not a huge amount of O&M is necessary, hydro plants tend to become increasingly less healthy if not kept in perfect condition (for example, replacing trash racks to keep small stones out). For these and other reasons, keeping an escrow

account for maintenance is advisable. Box 8 shows payments to an escrow account for maintenance for the Sawa example.

Box 8: Example—Sawa Hydro Project Income Statement

The first year's operating costs consist of feasibility studies, project development, and legal fees only (at US\$190,000, or TSh 285 million).

From 2012 onwards, annual operating costs (assuming a 5 percent inflation rate and a 6 percent TSh depreciation) are as follows (amounts in TSh millions):

Item	2012	2013	...	2020
Salaries	33	37		79
Insurance	17	19		39
O&M	167	186		393
Administration	83	93		197
Reserve account for maintenance	33	37		79
Total	334	372		786

Sawa's income statement is necessary to calculate the tax expense. The consolidated income statement (in TSh millions) looks as follows:

	2011	2012	2013	2014	2015	2016	2017	2018	2019	2020
Revenues		1,464	1,523	1,584	1,647	1,713	1,781	1,853	1,927	2,004
OPEX	285	334	372	414	460	512	570	635	706	786
EBITDA	(285)	1,130	1,151	1,170	1,187	1,200	1,211	1,218	1,220	1,217
Interest	370	392	416	386	350	310	262	209	147	78
Depreciation	375	375	375	375	375	375	375	375	375	375
EBT	(1,030)	363	360	409	461	516	574	634	698	764
Tax	0	109	108	123	138	155	172	190	209	229
Net profit	(1,030)	254	252	286	323	361	401	444	488	535

Source: Authors' illustration.

Note: EBITDA = Earnings Before Interest, Taxes, Depreciation and Amortization.

EBT = Earnings Before Taxes

4.5.2

KEY RATIOS AND SENSITIVITY ANALYSIS FOR A HYDROPOWER PROJECT

Cash flow statement and key ratios

Boxes 9 and 10 provide the cash flow statement and key ratios for the Sawa example. As observed, except for the calculation of energy and power revenues in the model, which are specific to this type of project, the rest of the model should not seem strange to the lender.

Box 9: Example—Sawa Hydro Project Cash Flow Statement

	2011	2012	2013	2014	2015	2016	2017	2018	2019	2020
Revenues		1,464	1,523	1,584	1,647	1,713	1,781	1,853	1,927	2,004
OPEX	285	334	372	414	460	512	570	635	706	786
Taxes	0	109	108	123	138	155	172	190	209	229
Operations	(285)	1,021	1,043	1,047	1,048	1,046	1,039	1,028	1,011	988
Fixed assets	(3,750)									
Investments	(3,750)									
Equity	1,322									
Loan	3,084									
Principal			433	459	487	516	547	580	614	651
Interest	370	392	416	386	350	310	262	209	147	78
Financing	4,035	(392)	(849)	(845)	(837)	(825)	(809)	(788)	(762)	(729)
Total CF	0	629	194	202	211	220	230	239	249	259
Project CF	(4,406)	1,021	1,043	1,047	1,048	1,046	1,039	1,028	1,011	988
Equity CF	(1,322)	629	194	202	211	220	230	239	249	259

Source: Authors' illustration.

Note: CF = cash flow.

Box 10: Example—Sawa Hydro Project Key Financial Ratios

The project roughly meets standards, with an average ADSCR of 1.36 and an equity IRR of 17 percent. In several years, however, the ADSCR will be on the low side.

Ratio	Entire project	2012	2013	2014	2015	2016	2017	2018	2019	2020
ADSCR	1.36	2.60	1.23	1.24	1.25	1.27	1.28	1.30	1.33	1.35
Project IRR	18%									
Equity IRR	17%									

Source: Authors' illustration.

Note: ADSCR is calculated as: cash flow from operations / (interest plus principal payment).

Sensitivity analysis

As discussed in chapter 3 (Project Finance), as a final step, an analysis needs to be conducted testing the financial model for changes in key variables (box 11). As for all projects, common factors to check are the model's sensitivity to changes in:

- Capital expenditures and construction delays;
- Operating expenditures;
- Macroeconomic variables, such as exchange rates and inflation rates;
- Bank interest rates; and
- Energy tariffs.

In addition, for hydropower projects, effects from changes in the capacity factor and water flow on debt-servicing capacity should be carefully monitored. Also, impacts from incurring additional costs due to grid trip-outs and the need to purchase back-up power as a result of technical difficulties should be monitored (see section 3.6.7).

Box 11: Example—Sawa Hydro Project Sensitivity Analysis

The table below provides an overview of the effect of a number of changes on key financials versus the baseline case. The figures clearly demonstrate the critical importance of reliable estimates for capacity factors, water flows, and construction times.

	Project IRR (%)	Equity IRR (%)	Average ADSCR
Capacity factor down to 60%	13	negative	1.13
Water flow down to 5.5 m ³ /second	15	4	1.22
A one-year construction delay	11	negative	1.16
SPPT not adjusted (remains at 2011 rate)	13	negative	1.07
Annual inflation on OPEX increases to 10%	16	2	1.20
Annual depreciation TSh increases to 10%	17	negative	1.03
Annual additional OPEX of US\$50,000	15	4	1.22
Worst case: all of the above occur at once	negative	negative	0.12

4.6**FURTHER INFORMATION**

DFID, and World Bank. 2000. "Best Practices for Sustainable Development of Micro Hydro Power in Developing Countries."

<http://practicalaction.org/docs/energy/bestpractsynthe.pdf>.

ESMAP (Energy Sector Management Assistance). 2002. *Mini Hydropower Development Case Studies on the Malagarasi, Muhuwesi, and Kikuletwa Rivers*, Volumes I, II, and III. <http://www.esmap.org/esmap/node/705> and <http://www.esmap.org/esmap/node/706>.

GTZ (German Agency for Technical Cooperation). Undated. "Economics of Mini Hydropower Projects."

http://agmhp.aseanenergy.org/media/documents/2010/10/15/fi/file_1.pdf.

International Center on Small Hydropower. Undated. "A Practical Guide to Assessment and Implementation of Small Hydropower."

<http://www.inshp.org/THE%203rd%20HYDRO%20POWER%20FOR%20TODAY%20Forum/Presentations/Australia/A%20Practical%20Guide%20to%20Assessment%20and%20Implementation%20of%20Small%20Hydropower.pdf>.

Kabaka, K. T., and F. Gwang'ombe. 2007. "Challenges in Small Hydropower Development in Tanzania: Rural Electrification Perspective."

<http://ahec.org.in/links/International%20conference%20on%20SHP%20Kandy%20rilanka%20All%20Details%5CPapers%5CPolicy,%20Investor%20&%20Operational%20Aspects-C%5CC7.pdf>.

Microhydropower.net. Undated. "Hydropower Basics: Civil Work Components."

<http://www.microhydropower.net/basics/components.php>.

Microhydropower.net. Undated. "Hydropower Basics: Turbines."

<http://www.microhydropower.net/basics/turbines.php>.

Practical Action. Undated. "Technical Brief: Micro Hydropower."

http://www.itdg.org/docs/technical_information_service/micro_hydro_power.pdf.

TaTEDO. 2007. "Business Plan: 70 kW Micro-Hydroelectric Plant in Zege Village."

http://toolkits.reeep.org/file_upload/10501005_10.pdf.

Web sites:

- International Hydropower Association, <http://www.hydropower.org>
- International Network on Small Hydropower, <http://www.inshp.org>
- Portal on micro hydropower, <http://microhydropower.net/>

CHAPTER

5 Biomass

Biomass energy ranges from household cooking to multimillion U.S. dollar projects feeding power into the grid. A large variety of technology choices is available, some of which are well established and “bankable,” like power generation from wood chips.

5.1

INTRODUCTION TO BIOMASS

Biomass refers to biological material from living or recently living organisms. There are many types of biomass that can be used as an RE resource, and each has different properties such as heating value, moisture content, and mineral content (table 11). These have an impact on the combustion (burning) process, so it is important that the technology chosen for a particular project is compatible with the biomass used. The most suitable technology for a project depends on many factors, such as availability and cost of biomass, alternative fuel cost, scale of operation, and type of energy (heat and/or electricity).

Table 11: Typical Biomass Fuel Characteristics

Sector	Residues	Heating value (MJ/kg)	Moisture content (% wet basis)	Mineral content (% dry basis)
Rice	Rice husk	13–14	9–12	20
Sugar	Bagasse	7–8	45–50	3–4
Palm oil	Fresh fruit bunch	7–8	45–50	5.5
	Fibers	10–11	38–40	5.8
	Shells	17–18	22–25	2
Wood	Shavings, offcuts, and others	11–12	30–35	1–2

Source: COGEN3 (2004).

Energy technologies for solid biomass can be grouped into two main categories: **direct combustion** and **thermo-chemical processes**:

- Direct combustion includes basic systems like cook stoves and stoker boilers as well as more advanced systems such as fluidized-bed combustion.
- Thermo-chemical conversion produces a higher-value fuel that is more convenient to use and transport. The main processes are charcoal making and gasification.

Sections 5.2 and 5.3 discuss the basic technicalities of **direct combustion** and **gasification** in more detail. Both sections focus on industrial and commercial applications, because these are the most relevant for financial institutions in Tanzania.

5.2

DIRECT COMBUSTION SYSTEMS

Most biomass power plants use direct combustion systems, which burn biomass in boilers to produce high pressure steam. Subsequently the steam turns a turbine connected to a generator which generates electricity. This is the simplest and oldest way to generate electricity from biomass. Direct combustion systems for power generation are well established and proven, with plants in operation throughout the world.

Biomass requirements for power generation in direct combustion plant:

- 1–1.3 ton of biomass per megawatt hour of electricity

Biomass power plants using direct combustion typically require 1–1.3 ton of fuel per MWh of electricity, depending on the type of fuel, scale of operation, and system efficiency. Combined heat and power (CHP) or cogeneration systems use the extracted steam for heating purposes. This greatly increases overall energy efficiency up to 80 percent, compared to electricity-only systems, which can only convert and use 20–25 percent of total energy burned. Common applications include cogeneration at sugar mills using bagasse as fuel.

5.2.1 COMPONENTS OF DIRECT COMBUSTION SYSTEMS

A basic direct combustion system for power generation is made up of several key components (figure 3), usually including the following items:

- Fuel storage;
- Fuel preparation, processing, and handling equipment;
- Combustor/furnace;
- Boiler;
- Steam turbine:
- Generator;
- Condenser;
- Water treatment system; and
- Exhaust and emissions controls system.

Figure 3: Schematic Diagram of a Direct Combustion Steam-Cycle System

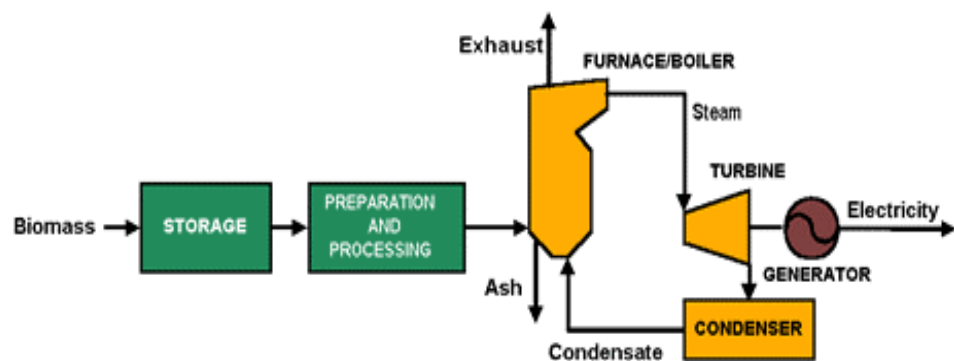

Source: Biomass for Electricity Generation, by U.S. Department of Energy Federal Energy Management Program (FEMP), <http://www.wbdg.org/resources/biomasselectric.php>.

Biomass power plants require fuel storage and equipment for **fuel handling**. A bunker or silo can be used for short-term storage, and an outside fuel yard for larger storage. For even larger systems, an automated control system conveys the fuel from the storage to the combustor system using a combination of cranes, belts, and other systems.

- Check if the exhaust system is in line with environmental regulations

Regardless of the technology or project scale, fuel handling and **preprocessing** are crucial aspects of biomass projects. The overall process efficiency can be improved by *drying the biomass* before combustion, but this may not be economically feasible due to the additional costs.

Exhaust systems are used to release combustion by-products into the environment. Emission controls might include a cyclone or multicyclone, a baghouse, or an electrostatic precipitator to remove particles. To mitigate environmental risks, emission controls for unburned hydrocarbons, oxides of nitrogen and sulfur might be required, depending on fuel properties and environmental regulations.

5.2.2 DIRECT COMBUSTION FURNACES

The three main types of direct combustion systems are grate furnaces and suspension-fired and fluidized-bed combustors.

Grate furnaces

In a grate furnace (or stoker boiler), the fuel is burned on a grate. The grate can either be fixed or moving; the latter allows continuous fuel feeding and ash removal so that the plant can run continuously and more efficiently.

Grate furnaces are widely available and in a wide range of sizes (1–250 MW_{th}), at relatively low costs. Modifications to the basic grate such as inclined grates and water-cooled grates improve the overall performance and make the operation less sensitive to fuel moisture. Stoker combustors have boiler efficiencies of 65–75 percent.

Suspension-fired combustion

In suspension combustion, there is no grate and the fuel is blown into the combustion chamber through a specially designed burner that mixes air with the fuel, which then burns in the body of the combustion chamber. Finely ground wood, rice husk, bagasse, or sawdust can be burned in this way.

Suspension firing typically requires extensive biomass drying and processing facilities to ensure that the fuel is of the right consistency. The moisture content should be below 15 percent, and the biomass particle size has to be less than 15mm. Suspension-fired combustion systems have boiler efficiencies of up to 80 percent.

Fluidized-bed systems

In a fluidized-bed combustor (FBC), the biomass is burned in a hot bed of suspended, incombustible particles, such as sand. This is the most efficient method of directly burning biomass, as well as the most versatile since the system can cope with a wide range of fuels and moisture contents (up to 50 percent).

Compared to grate combustors, fluidized-bed systems generally produce more complete carbon conversion, resulting in reduced emissions and improved system efficiency. Efficiencies for fluidized bed boilers are 75–85 percent.

The most common FBC system is the circulating fluidized bed, in which a cyclone filter separates the solid materials from the hot flue gases that are used to generate steam, after which the solids are recirculated into the bed.

5.3

A biomass gasification system turns biomass into gas, which is then burned in a gas burner

GASIFICATION

A biomass gasification plant turns the biomass into gas, which is then burned in a gas burner or engine. Biomass gasification is a thermo-chemical process that involves the burning of solid biomass under a restricted supply of oxygen, which produces a combustible gas. Fuel sources suitable for biomass gasification include wood chips, charcoal, corn cobs, rice husks, and coconut shells.

The gas produced by a gasifier is a low calorific value gas commonly called “producer gas” that has carbon monoxide, hydrogen, and methane as its main combustible components. Its calorific value varies between 4.0 and 6.0 megajoule per normal cubic meter (MJ/Nm³), about 10 to 15 percent of the heating value of natural gas. The gas can be used for heating, cooking, and the generation of electricity or shaft power.

Compared to direct combustion, gasification is less mature and its application is not yet as common. Nevertheless, in recent years, significant technological developments have taken place and it is becoming a more attractive option, especially for small- to medium-sized industries with a supply of biomass and the need for reliable and affordable energy.

5.3.1

COMPONENTS OF GASIFICATION SYSTEMS

A biomass gasification system consists primarily of a reactor into which the biomass is converted into gas, and associated equipment such as ash removal, scrubbers, and gas filters. Figure 4 shows a schematic illustration of a gasifier.

After the conversion of the solid biomass into gas in the reactor, the remaining char and ash are removed at the bottom of the gasifier. The hot gas coming out of the reactor is suitable for direct combustion in a gas burner. However, for engine applications, the gas needs to be cooled down and cleaned, because it contains significant amounts of tar, soot, ash, and water. The first step in this process is for the gas to pass through a water scrubber, which cools the gas and removes part of the tars and ash. Next, the gas is led through a series of filters to remove any remaining particles.

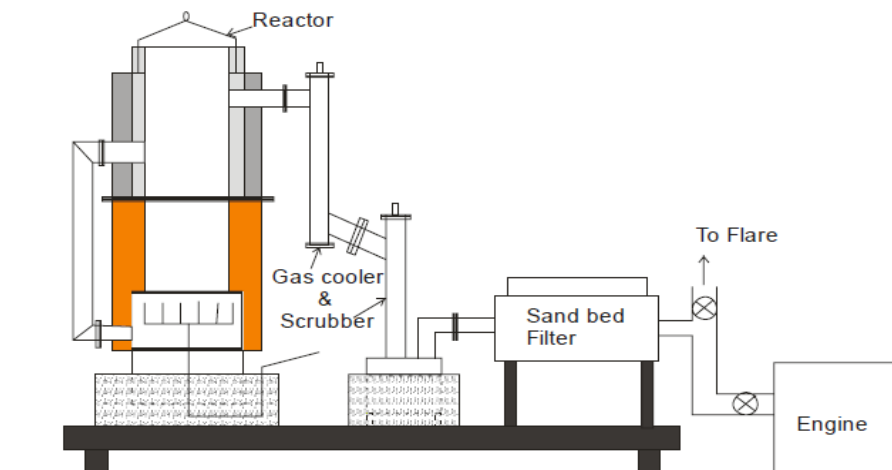
Figure4: Schematic Illustration of a Gasifier

Source: G. Sridhar, H. V. Sridhar, and M. S. Sudarshan, et al., "Case Studies on Small Scale Biomass Gasifier Based Decentralized Energy Generation Systems," Centre for Sustainable Technologies, Indian Institute of Science, Bangalore (2006).
<http://cgpl.iisc.ernet.in/site/Portals/0/Publications/NationalConf/CaseStudiesOnSmallScaleBiomassGasifier.pdf>.

5.3.2 GASIFICATION SYSTEMS

Similar to direct combustion, gasifiers can be grouped into fixed-bed and fluidized-bed systems.

- **Fixed-bed systems:** In these systems, the biomass is fed into the system at the top of the reactor and slowly moves down by gravity. Fixed-bed systems are either downdraft or updraft, referring to the direction of the gas flow through the reactor. Downdraft gasifiers produce a gas with lower tar content than updraft gasifiers, and therefore are more suitable for use in engines and power generation in the range of 50–500 kW_e (kilowatt electrical). Small-scale systems are usually fixed-bed systems because of the lower investment costs and simpler operation.
- **Fluidized-bed systems:** Larger systems (>10 MW_{th}) typically use fluidized-bed gasifiers. Similar to FBC, the fuel is fed into a hot sand bed that behaves like a fluid. Compared to fixed-bed gasifiers, fluidized-bed systems are more flexible to changes in fuel characteristics such as moisture and ash content.

Gasification systems range from simple systems that are largely manually fed and operated to fully automated systems with sophisticated controls. Gasifiers are manufactured mostly in Europe, the United States, India, and China. Currently, India has the most suppliers of reliable and affordable systems suitable for small- to medium-scale applications.

Biomass requirements for power generation in gasification plant:

- 1.3–1.5 kg of biomass per kWh of electricity
- 4–6 kg of biomass to replace 1 liter of diesel

Biomass requirements depend on the system, the type of fuel, and the application. For power generation using gasification, the biomass requirement is about 1.3–1.5 kg/kWh of electricity. For applications that offset the use of diesel, roughly 4–6 kg of biomass are needed to replace 1 liter of diesel.

Gasifiers are fairly sensitive to fuel quality fluctuations and require adequate O&M. The fuel needs to be supplied regularly and at the right specifications and filters require regular cleaning.

5.4 BIOMASS OPPORTUNITIES IN TANZANIA

Biomass is currently the main source of energy in Tanzania, accounting for more than 90 percent of the country's primary energy supply. Biomass is consumed mostly by households in the form of fuelwood and charcoal for use in traditional and largely inefficient cookstoves.

The total biomass resource in Tanzania is estimated to be roughly 40 million tons, consisting of forestry residues (for example, sawdust, wood chips, and offcuts) and agricultural residues (for example, rice husks, corn cobs, sisal wastes, and cotton stalks). However, it is not always economically viable to collect and use the resource for energy purposes because of logistical issues and other end uses for biomass.

Nevertheless, there are various opportunities for implementing biomass energy projects, particularly for industries with an onsite biomass resource, such as in sawmilling, rice milling, coffee roasting, and other agroindustries. Direct combustion systems are suitable for installations at or near large agricultural or forestry operations to supply local industries and sell electricity to the grid. Gasification, on the other hand, can be an attractive option for small-scale agroindustries that currently operate on diesel or face high costs and reliability issues with electricity.

In Tanzania, biomass projects are typically developed or co-owned by plantations (coconut, timber, sisal, and sugar). These companies use the residues generated in their day-to-day operations as feedstock for the power plants.

A number of companies are already producing power from cogeneration technologies (combined heat and power). Some of the companies are selling (or plan to sell) excess capacity to the TANESCO grid. Among these companies, sugar plantations are very prominent; previous studies, for instance, show that Tanzania's four sugar companies could generate 200 MW from cogeneration.²¹

Companies selling (or planning to sell) excess power to the TANESCO grid include TPC Ltd., Kilombero Sugar Company, Mtibwa Sugar Estates, Tanzania Wattle Industry, and Mufindi Paper Mill.

5.5

KEY CONSIDERATIONS FOR FINANCING BIOMASS PROJECTS

When reviewing a biomass project, the main issues specific to biomass can be grouped into four categories, which are discussed in more detail in the following sections:

- Biomass feedstock;
- Technology;
- Investment costs and revenues; and
- By-products and waste handling.

5.5.1

BIOMASS FEEDSTOCK

The **key** issue for biomass projects is securing a reliable and affordable fuel supply. The operational costs and profitability of a project are highly dependent on feedstock price and availability, because feedstock typically represents 25–40 percent of the project's lifetime costs. Therefore, significant effort must be made upfront to ensure the plant will have enough fuel to operate commercially for its lifetime.

To determine whether the supply is secure, factors such as current uses, price fluctuations, potential future demand, as well as logistics and transportation costs must be reviewed. Rough estimations, such as global desktop assessments of residues generated in a particular area, are insufficient. Experience in other markets shows that a biomass resource that was previously available cheaply and abundantly can quickly become scarce and expensive due to the development of multiple biomass energy projects and an increase in other market demands.

The biomass resource also affects the feasibility of the project size. To achieve economies of scale, it may be desirable to set up large systems. However, in practice, the size of a project is limited by the availability and logistics of the biomass supply. Because biomass is bulky and low density compared to fossil fuels, and due to Tanzania's high transportation costs, it is not commercially feasible to transport it over distances of more than 100–200 kilometers. This is especially true for projects feeding the main grid where tariffs are lower.

To mitigate feedstock risks, project developers can sign long-term supply contracts with biomass suppliers, although these may be of limited value when a resource becomes

The **key** issue for biomass projects is securing a **reliable and affordable** fuel supply

Feedstock typically represents 25–40 percent of the project's lifetime costs

²¹ GTZ, <http://www.gtz.de/de/dokumente/gtz2009-en-regionalreport-tanzania.pdf>.

scarce. One way to secure a long-term supply is to include incentives and additional payments for suppliers that deliver over long periods, so they remain committed even when market prices go up. Another option is to explore co-ownership in a project with a biomass resource owner (for example, a rice mill), to strengthen the supply security. Perhaps the ideal situation would be that the owner of a captive and concentrated feedstock location, such as a sugar mill, a timber mill, or a large rice mill, decides to invest in biomass power production. Finally, another important factor is whether the project can handle multiple fuel types, so it can switch if necessary. When selecting the technology, the ability to switch fuels is a plus.

Mitigation:

- Solid research
- Long-term supply contracts or co-ownership of the resource owner
- Technology allowing for multiple fuels
- Sensitivity analysis
- Cash and feedstock reserves

There are several other strategies to mitigate the risks related to feedstock. First of all, it is important to understand the sector that is supplying the feedstock. For example, for a rice husk-based project, the rice growing and milling sectors should be studied to understand seasonal patterns, pricing, and relationships between farmer and millers. Second, because prices and availability can vary widely, financial analysis should include a sensitivity analysis to assess the project's performance under pessimistic feedstock scenarios to identify the most critical factors. An example of a sensitivity analysis is included in section 5.6, Financials of Biomass. Third, the project should create sufficiently large cash and feedstock reserves to be able to deal with significant supply disruptions.

5.5.2

TECHNOLOGY

As discussed earlier, there are several technology choices available. While each type has its merits and drawbacks, it is important to select technologies that have been proven in similar applications. Furthermore, it is also important to work with reliable and reputable suppliers that provide adequate warranties to protect against malfunctioning and/or underperforming equipment.

The technology should match the project size. Direct combustion technologies, for instance, are typically used for projects of 2–3 MW and above. Below that, gasification would be more appropriate.

For project construction, it is recommended to sign an EPC contract with a contractor firm, under which the contractor will conduct the detailed engineering design, procure the equipment and materials, and construct the plant. The EPC contract mitigates the technology risk, because it usually includes guarantees and penalties to protect against construction delays and underperformance.

It is crucial that the combustion system is designed for the specific type of biomass being used, because different types of biomass have different characteristics (refer back to table 8). For example, rice husks have a high mineral or ash content that can lead to significant slagging or clinker formation caused by melting and agglomeration of ashes during combustion.

And again, the project should be able to handle multiple fuels to mitigate feedstock risk. Therefore, confirm that the technology of choice can deal with multiple fuels, because fuel properties vary between different types of biomass and not all technologies may be able to adapt.

To mitigate technology risks, a financial institution should hire an outside technology expert to provide an independent opinion on the proposed project and engineering designs. A thorough background check on the reputation of suppliers and contractors and their references should be conducted as well.

5.5.3

INVESTMENT COSTS

Investment costs for biomass projects can vary widely depending on factors such as project size, technology, origin of equipment, and import tariffs. As of yet, there are no import duty exemptions for RE equipment in Tanzania.

Direct combustion power generation plants typically have investment costs of US\$1,500–US\$3,000 per kW of installed capacity. This includes project development, land, electro-mechanical equipment, civil works, interest during construction, and working capital.

The cost of a basic fixed-bed gasification system is roughly US\$1,000–US\$2,000 per kW. This includes site development, civil structure, genset, and the gasifier and auxiliary

systems. For systems that do not generate electricity and burn the gas in a furnace, the costs can be considerably lower, since they require no genset and a less elaborate gas cleaning system.

5.5.4 WATER REQUIREMENTS, BY-PRODUCTS, AND WASTE HANDLING

Apart from feedstock, biomass projects require considerable amounts of water for steam generation and cooling. This has to be carefully accounted for during project development, both to ensure sufficient availability of water and to minimize the environmental impacts of water use. The water used for cooling is usually much warmer when it is returned to the lake or river than when it was removed, so the higher temperature can harm aquatic life.

Thermal power plants using steam turbine (both for fossil fuel and biomass plant) consume 1.1–1.8 liters of water per kWh electricity generated, depending on the technology and scale of operation.²² For gasification systems, the requirement is about half of thermal plants.

Whether applying direct combustion or gasification, biomass projects generate solid, liquid, and gaseous waste that, if not adequately controlled, may harm the environment.

Air emissions vary depending on the fuel, technology, and pollution controls installed at the plant. While sulphur emissions are typically lower than for coal plants, emissions of concern are nitrogen oxides, carbon monoxide, volatile organic compounds, and particulate matter. Regardless of the technology, appropriate measures should be taken to minimize harmful emissions. These include proper operational procedures and emission control systems such as electrostatic precipitators. The National Environment Management Council is responsible for issuing permits and enforcing environmental standards in accordance with environmental laws and regulations.

Gasification projects typically generate liquid effluents (that is, spent scrubber water) that are toxic and need to be treated and disposed of properly. Effluents can be treated using activated carbon or biological systems. Costs for water treatment systems can vary widely depending on the technology used and environmental standards.

Similar to technology issues, the lender should obtain independent expertise to ensure the project takes appropriate measures to minimize environmental impacts and comply with environmental regulations.

5.6 THE FINANCIALS OF BIOMASS

This section discusses the financial analysis of biomass projects using an example called “Kuni Energy.” Kuni Energy is a 7.5 MW project generating electricity to be sold to TANESCO’s main grid under an SPPA. The project uses wood waste from nearby sawmilling and forest plantations.

The example focuses on factors typical to biomass projects, such as feedstock supply. The example is meant as an illustration, and actual projects may look different.

5.6.1 THE FINANCIAL MODEL

Revenues

For grid-connected biomass projects, the main source of revenue is electricity sales (box 12), typically under a PPA. Some projects have additional revenue streams, for example, carbon offsets or ash sales. For financial analysis, as discussed in chapter 3 (Project Finance), these other potential sources of revenue should be disregarded because they may not be as reliable as electricity sales.

²² Sandia National Laboratory, with support from the National Energy Technology Laboratory and Los Alamos National Laboratory, *Energy Demands on Water Resources: 2006 Report to Congress on the Interdependency of Energy and Water*, www.sandia.gov/energy-water/docs/121-RptToCongress-EWwEIAComments-FINAL.pdf.

Box 12: Example—Kuni Energy Revenues

The 7.5 MW Kuni biomass project uses 7 MW net capacity for export (0.5 MW is for own use). The plant operates 340 days per year, and the project's expected annual energy generation for sale is: $7 \times 340 \times 24 = 57,120$ MWh

The project, which will run for 20 years (2011–30), will start selling energy in the third year (2013). Throughout the project, energy will be sold to TANESCO's main grid at the SPPA rate, anticipating an annual 4 percent tariff increase. Expected annual sales can hence be calculated as follows:

- Sales 2013 = $57,120,000 \times 121.13 \times (1.04)^2 =$ TSh 7,484 million
- Sales 2014 = $57,120,000 \times 121.13 \times (1.04)^3 =$ TSh 7,783 million
- Sales 2030 = $57,120,000 \times 121.13 \times (1.04)^{19} =$ TSh 14,577 million

Source: Authors' illustration.

Capital costs and financing structure

Capital costs for biomass energy projects typically include the following items (see also boxes 13 and 14):

- Engineering and project management;
- Biomass handling equipment (crane, belts, and storage);
- Civil works (buildings and roads);
- Electromechanical equipment (turbine, generator, controls, and so forth); and
- Grid connection.

Box 13: Example—Kuni Energy Capital Costs

The Kuni project requires a total investment of US\$13.5 million or US\$1,803 per installed kilowatt. Of this amount, US\$11.3 million is for the purchase of fixed assets (depreciated straight line over a 10-year period, no residual value). Applying a TSh/US\$ exchange rate of 1,500, the detailed specification of investment costs per item are in the table below.

Fixed assets	TSh	Other investment costs	TSh
Land and preparation	1,217	Feasibility studies	338
Civil structures	1,671	Project development	968
Electromechanical equipment	13,257	Interest during construction	1,917
Distribution network	818	Legal fees	105
Total fixed assets	16,962	Total other investments	3,327

Source: Authors' illustration.

Box 14: Example—Kuni Energy Financing Structure

To finance the US\$13.5 million investment cost, the project sponsors contribute 30 percent equity and demand 70 percent debt finance. Subsequently, the 9 percent loan amounts to US\$9,468,000. Half of the loan is obtained during the first year, the other half is obtained during the second year. There is a grace period of two years, after which the loan is paid back in eight equal annual installments (see table below; all amounts in thousands of U.S. dollars).

	2011	2012	2013	2014	2015	2016	2017	2018	2019	2020
Balance	4,734	9,468	9,468	8,610	7,674	6,654	5,542	4,330	3,009	1,569
Principal			859	936	1,020	1,112	1,212	1,321	1,440	1,569
Interest	426	852	852	775	691	599	499	390	271	141

For the purposes of the cash flow statement, however, the debt-service payments have to be converted to Tanzanian shillings. To this end, the project developer assumes that an annual 6 percent depreciation of the Tanzanian shilling to the U.S. dollar (starting from TSh/US\$ 1,500 in 2011). Applying this assumption, the annual installments are listed in the table below (expressed in millions of Tanzanian shillings):

	2011	2012	2013	2014	2015	2016	2017	2018	2019	2020
Principal			1,447	1,672	1,932	2,232	2,579	2,979	3,442	3,977
Interest	639	1,355	1,436	1,384	1,308	1,202	1,061	879	647	358

Source: Authors' illustration.

Operating costs

The annual costs of a biomass project consist of two main components: cost of sales and other operating expenditures. Cost of sales refers to biomass feedstock costs. The nonfuel operating expenses on the other hand typically reflect costs related to salaries, insurances, and maintenance. It should be noted that feedstock costs are significant and may amount to more than 20 percent of revenue.

Box 15: Example—Kuni Energy Income Statement

The first year's operating expenditures (OPEX) consist of feasibility studies and 50 percent of project development and legal fees. In 2012, the other half of project development and legal fees are due. From 2013, OPEX reflect salaries, insurances, O&M, and administration only. In 2013, OPEX are US\$500,000. Thereafter, OPEX annually increase by 5 percent.

Cost of sales refers to feedstock. The needs for feedstock are calculated as follows:

- Biomass needs = $(3.6 / \text{heating value (in MJ/kg)/plant efficiency}) \times \text{MWh generated}$.
- Annual biomass needs = $(3.6 / 15 / 27\%) \times 57,120 = 50,773 \text{ ton}$.

Given an assumed price of biomass of US\$15 per ton, in 2013 the cost of feedstock amounts to US\$762,000. Thereafter, the price of biomass annually increases by 5 percent.

All payments are due in Tanzanian shillings. For 2011, the expected TSh/US\$ exchange rate is 1,500. Thereafter, the Tanzanian shilling depreciates 6 percent annually relative to the U.S. dollar. The table below shows the resulting income statement for Kuni Energy (in millions of Tanzanian shillings):

	2011	2012	2013	(..)	2020	2021	(..)	2029	2030
Revenues			7,484		9,848	10,242		14,017	14,577
Cost of sales			1,284		2,716	3,023		7,118	7,922
OPEX	761	568	843		1,783	1,984		4,673	5,201
EBITDA	(761)	(568)	5,357		5,349	5,235		2,226	1,454
Interest	639	1,355	1,436		358				
Depreciation	1,696	1,696	1,696		1,696				
EBT	(3,097)	(3,620)	2,225		3,295	5,235		2,226	1,454
Tax	0	0	667		988	1,570		668	436
Net profit	(3,097)	(3,620)	1,557		2,306	3,664		1,558	1,018

Source: Authors' illustration.

Note: EBITDA = Earnings Before Interest, Taxes, Depreciation and Amortization; EBT = Earnings Before Taxes.

5.6.2

KEY RATIOS AND SENSITIVITY ANALYSIS

Cash flow statement

Box 16 shows the cash flow statement for the Kuni project. Project construction takes two years and it is assumed that the investments are equally spread out over two years.

Box 16: Example—Kuni Energy Cash Flow Statement (in millions of TSh)

	2011	2012	2013	(..)	2020	2021	(..)	2029	2030
Revenues			7,484		9,848	10,242		14,017	14,577
Cost of sales			(1,284)		(2,716)	(3,023)		(7,118)	(7,922)
OPEX	(761)	(568)	(843)		(1,783)	(1,984)		(4,673)	(5,201)
Taxes	0	0	(667)		(988)	(1,570)		(668)	(436)
Operations	(761)	(568)	4,690		4,361	3,664		1,558	1,018
Fixed assets	(8,481)	(8,481)							
Investments	(8,481)	(8,481)							
Equity	3,043	3,043							
Loan	7,101	7,101							
Interest	(639)	(1,355)	(1,436)		(358)				
Principal			(1,447)		(3,977)				
Financing	9,505	8,790	(2,883)		(4,335)				
Total CF	263	(260)	1,807		25	3,664		1,558	1,018
Project CF	(10,145)	(10,145)	4,690		4,361	3,664		1,558	1,018
Equity CF	(3,043)	(3,043)	1,807		25	3,664		1,558	1,018

Source: Authors' illustration.

Note: CF = cash flow.

Interpreting the model

The cash flow statement serves as input for the calculation of the major financial indicators (box 17), such as the IRR and ADSCR. As discussed in chapter 3, financial institutions typically have their own benchmarks for these ratios.

Box 17: Example—Kuni Energy Key Financial Indicators

The financial analysis of the base case of the Kuni project shows a fairly reasonable value for the equity IRR. The ADSCR, however, is on the low side. Further analysis is required to assess critical factors.

	2012	2013	2014	2015	2016	2017	2018	2019	2020
ADSCR		1.63	1.54	1.46	1.37	1.28	1.19	1.10	1.01
Key ratios									
Project IRR	18%								
Equity IRR	23%								
Average ADSCR	1.3								

Source: Authors' illustration.

Sensitivity analysis

Sensitivity analysis (box 18) is performed to identify the factors that have the most impact on the IRR and DSCR. Once identified, further investigation and additional mitigation measures may be needed to ensure project viability.

Box 18: Example—Kuni Energy Sensitivity Analysis

The sensitivity analysis for the Kuni project shows that all factors significantly affect project profitability and debt-service repayment capacity.

	Project IRR (%)	Equity IRR (%)	Average DSCR
Biomass price up to US\$20 per ton	15	16	1.17
Operating days down to 300	15	16	1.14
Plant efficiency down to 20%	15	15	1.16
SPPT remains at TSh 121.13/kWh	13	6	1.12
Annual inflation to 10%	negative	negative	1.16
Annual depreciation of TSh to 10%	negative	negative	0.93

Source: Authors' illustration.

5.7**FURTHER INFORMATION**

Asian Productivity Organization. 2009. "Biomass as Fuel in Small Boilers."

http://www.apo-tokyo.org/00e-books/GP-17_Biomass.htm.

COGEN3. 2004. *Cogeneration Project Development Guide*, 2nd Edition.

<http://www.cogen3.net/pdgform.html>.

UNDP (United Nations Development Programme). 2000. *Bioenergy Primer, Modernised Biomass Energy for Sustainable Development*.

<http://www.undp.org/energy/publications/2000/2000b.htm>.

U.S. Environmental Protection Agency. 2007. "Biomass Combined Heat and Power." Catalogue of Technologies, <http://www.epa.gov/chp/basic/catalog.html>.

World Bank. 1999. "Energy from Biomass: A Review of Combustion and Gasification Technologies." Technical Paper No. 422, http://www-wds.worldbank.org/external/default/main?pagePK=64193027&piPK=64187937&theSitePK=523679&menuPK=64187510&searchMenuPK=64187283&siteName=WDS&entityID=000094946_99033105581764.

CHAPTER

6 Biogas

Biogas is produced by a process called anaerobic digestion, in which bacteria break down liquid organic matter in the absence of oxygen. Anaerobic digestion occurs naturally in swamps, landfills, deep bodies of water, and in the digestive systems of humans and animals. Controlled anaerobic digestion takes place in a “digester,” which can be an airtight tank or a covered lagoon. Biogas is mostly produced from animal manure, sewage sludge, municipal solid waste, or agro-food-processing waste. Biogas production is different from biomass gasification, which is discussed in chapter 5, and produces gas from solid biomass.

6.1

INTRODUCTION TO BIOGAS

Biogas can be used for a variety of applications such as cooking, space heating, shaft work and power generation, both for industrial applications or household use. Apart from energy generation, the benefits of biogas production can include waste treatment, fertilizer production, GHG emission reduction, and elimination of odor.

Biogas produced in anaerobic digesters typically consists of about 60 percent methane and 40 percent CO₂, with trace amounts of other compounds such as hydrogen, nitrogen, and oxygen. The exact composition of biogas depends on the kind of feedstock material, the type of digester, and operational procedures.

Biogas projects vary in size and can be classified into two categories: domestic biogas and industrial biogas.

- **Domestic biogas** has been successfully introduced in many countries, particularly in Asia. In Tanzania, domestic biogas is promoted by several projects and NGOs, including TaTEDO. Numerous domestic systems have been installed at household-size livestock farms using animal manure to produce biogas, mostly used for cooking, replacing fuelwood and charcoal.
- **Industrial applications of biogas** have also become more common in other parts of the world, particularly at large-scale livestock farms and agroindustries. Industrial biogas systems treat the organic waste water from agro-food-processing facilities and often generate both heat and electricity. In Tanzania, expertise and experience in industrial biogas projects are still limited.

6.1.1

COMPONENTS AND TECHNOLOGY

Biogas systems are made out of concrete, steel, brick, or plastic. Whether for domestic or industrial applications, a biogas system typically incorporates the following basic components:

- **Feedstock collection:** Existing manure or wastewater systems can be adapted to collect the waste and deliver it to the digester. For large-scale systems, this often includes a premixing tank to adjust certain waste stream properties (for example, pH levels).
- **The digester:** Biogas is generated in the digester, which is the heart of the system (figure 5). Several designs are available and are detailed in section 6.1.2.
- **Gas-handling system:** This is the system in which the biogas is captured, treated (to remove moisture and hydrogen sulfide), and piped to the gas-using devices.
- **Gas-using devices:** Depending on the application, these include domestic lamps and cookstoves and industrial furnaces and engines. Industrial systems also have a flare installed to burn surplus gas.

- **Effluent handling:** The sludge exiting the digester is rich in nutrients (for example, ammonia, phosphorus, and potassium) and can often be used as fertilizer.

Figure5: Basic Design of a Fixed-Dome Biogas Digester

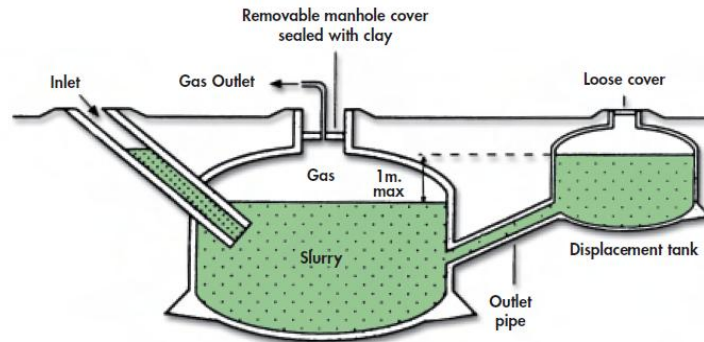

Source: UNDP.

6.1.2

DIGESTER DESIGNS: DOMESTIC AND INDUSTRIAL SYSTEMS

Several types of digester designs exist. The choice for a particular design depends on the feedstock material, scale of operation, and intended use of the gas.

Domestic systems

- The **floating-cover digester** is the most popular in India, in which a gas holder floats on a central guide and provides constant pressurization of the produced gas. The reactor walls are generally brick or concrete and the cover is made of mild steel. The digester is fed semi-continuously, with input slurry displacing an equivalent amount of effluent sludge.
- The **fixed-dome design** is the most commonly used system in China (and in Tanzania), in which biogas accumulates under a fixed brick or concrete dome, displacing effluent sludge as the gas pressure builds. The digester can be made from locally available materials but requires skilled masonry work.
- The **tubular plastic digester** is a long flexible cylinder composed of sheets of PVC or polyethylene that is placed in a trench so that the bag is half underground. The gas produced can be stored in the digester or a separate gas bag. This system is cheaper than the floating-cover or fixed-dome systems, but more prone to damage.

Industrial systems

- **Covered lagoon systems** are either constructed by excavation or adaptation of an existing pond. They are usually covered with synthetic fabric. The system is not heated and works under ambient temperatures so gas production will vary with temperatures. In colder regions it may cease entirely without supplemental heating, but in the tropics a covered lagoon will produce gas year round. Lagoon systems typically have low maintenance requirements compared to other systems.
- A **complete mix digester** is basically a tank in which the organic matter is heated and mixed with an active mass of microorganisms. Incoming liquid displaces volume in the digester, and an equal amount of liquid flows out. Biogas production is maintained by adjusting the volume of incoming liquid so that the solids remain in the digester for 20 to 30 days. A complete mix digester can be an above-ground or inground tank that is circular, square, or rectangular in shape. The digester should be heated and insulated.

6.2

BIOGAS OPPORTUNITIES IN TANZANIA

In Tanzania to date, biogas is principally perceived as a domestic energy technology— an alternative for rural households or institutions (for example, schools and hospitals) that currently rely on fuelwood and charcoal. Biogas was first introduced in the country in the 1970s by NGOs. Since then, over 100 rural masons have been trained and about 3,000 biogas digesters have been installed, the majority with a fixed-dome design. Biogas technology has great potential in areas where livestock is kept indoors for most of the time, but the high up-front cost of the system is an obstacle for many farmers and institutions.



Domestic fixed-dome biogas system being constructed in Tanzania
www.biogas-tanzania.org

The **commercial market** for biogas systems is quite young with few service providers and primarily focused on household systems. In 2008, the Tanzania Domestic Biogas Programme (TDBP) was launched as a multistakeholder initiative to develop the biogas sector as a whole, with the goal of installing 12,000 systems. The TDBP maintains a list of active biogas system providers, which includes monthly updates on the number of installed systems in Tanzania.²³

For the **industrial sector**, biogas provides a practical solution for wastewater treatment and energy generation. Mid- to large-scale livestock and agroindustries that generate large volumes of organic wastewater (for example, starch mills) and require energy are potential targets. As of yet, there is little in-country experience with industrial biogas. As a consequence, outside expertise needs to be brought in for initial projects. This could be accomplished through build-own-operate-transfer (BOOT) investment structures (box 19).

Box 19: BOOT Structure for Industrial Biogas Development

A potential strategy to stimulate industrial biogas development is the BOOT investment structure. Using the BOOT approach, the project is developed at an industrial facility (the “host company”) by a developer who takes care of project development, financing, and engineering with little to no investment from the factory. The project is typically set up as a separate legal entity (as a special purpose company [SPC]).

BOOT contracts between the SPC and host typically run for 10–12 years, after which the project’s assets are transferred to the host. During the BOOT period, the host supplies land and wastewater to the SPC, which supplies electricity and gas to the host at reduced rates compared to current tariffs (10–20 percent). The contract should set minimum wastewater volume and quality to protect the project’s interest.

Biogas BOOT projects have been developed successfully at starch and palm oil mills in Southeast Asia. Similar projects could be implemented in Tanzania at factories that have organic waste streams (liquid or solid) and available land, and require thermal and/or electrical energy.

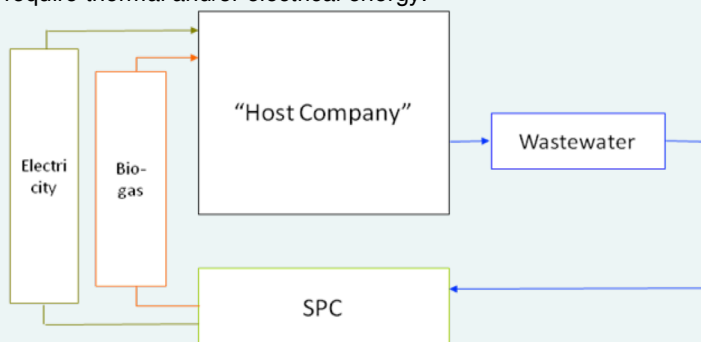

Source: Authors’ compilation.

6.3

KEY CONSIDERATIONS FOR FINANCING BIOGAS PROJECTS

Main issues to consider for financing industrial biogas projects include:

- Waste stream quality and volume;
- Technology;
- Investment costs and revenues; and
- By-product and waste handling.

²³ TDBP Web site, <http://www.biogas-tanzania.org/>.
 Reference manual

6.3.1 WASTE STREAM QUALITY AND VOLUME

To be feasible, the waste stream should contain sufficient and consistent amounts of organic materials. This is measured in the form of COD (chemical oxygen demand) and BOD (biological oxygen demand).²⁴ Generally speaking, the higher the COD and BOD, the higher the organic contents of the waste stream and the higher the biogas generation potential. For domestic systems, the number of livestock is usually a sufficient indication of the viability of a biogas system. For industrial systems, COD and BOD measurements need to be conducted over an extended period to assess project feasibility.

Apart from the waste stream volumes, the consistency of supply is important. Strong fluctuations in COD and BOD can seriously affect the bacteria in the system and even disrupt biogas generation. Therefore, the possibility of seasonal or market-induced disruptions in delivery of the waste stream should be carefully assessed. Other factors that affect the rate and amount of biogas production include pH, water/solids ratio, carbon/nitrogen ratio, and the mixing of digesting material. These should be continuously monitored and adjusted when needed before feeding the digester.

6.3.2 TECHNOLOGY

Several biogas technologies are available for industrial applications, each with different strengths. Where possible, it is important to assess the performance of a particular technology in a similar situation (type of waste, scale, climate, and so forth).

The project developer should engage a technology supplier with significant experience with different waste streams. The design of the system is critical, and it needs to be carefully designed by experts to ensure that the process will generate gas under various operating conditions.

Some types of waste streams lead to a high sulphur content in the biogas, for example, modified starch production. If the project will generate electricity, it should install gas scrubbers to remove the sulphur, because it can seriously corrode the generating equipment.

A financial institution reviewing an industrial biogas project should obtain outside expertise to review the project setup and technology to ensure project viability.

6.3.3 INVESTMENT COSTS AND REVENUES

Domestic biogas system prices depend on the size of the system, but generally range from US\$500 for a household system based on four cattle in a zero-grazing unit, to US\$10,000 for larger (institutional) systems.

Investment costs for industrial systems are less standardized and can vary widely depending on the scale, type of waste treated, application (for example, electricity or gas only, grid connection or stand-alone, and so forth), and technology. Nevertheless, it can safely be stated that because industrial systems treat waste at higher throughput rates compared to domestic systems, costs per unit of gas production are significantly lower, making this technology highly competitive with many fossil fuel alternatives.

Biogas projects tend to directly replace other energy sources, in households and industries, which means that project viability is often based on savings rather than sales. If that's the case, it may be necessary to conduct an analysis of past and future trends of alternative energy prices to assess project feasibility. However, biogas projects also have additional benefits (for example, odor control and waste treatment) that are not always expressed in monetary terms, but may be a compelling reason for project development.

Because of the high methane content, biogas projects have the potential to generate significant additional revenue from offsets of carbon emissions. For instance, given that methane is 21 times more effective in trapping heat in the atmosphere than CO₂, capturing and burning it implies a significant reduction in emission levels. This reduction can be monetized under the CDM or voluntary schemes such as the Gold Standard or

²⁴ COD is the amount of oxygen required to chemically oxidize the organic matter in a waste stream. BOD is the amount of oxygen required to biologically (aerobically) degrade the organic matter in a waste stream.

Voluntary Carbon Standard. In some cases, this can contribute up to 60 percent of total project revenue. Nevertheless, as discussed in chapter 3 (Project Finance), CDM involves a lengthy and costly process. Therefore, the financial analysis should explore the case without CERs to assure the project is feasible without it.

6.3.4 BY-PRODUCT AND WASTE HANDLING

Although biogas systems are able to significantly clean the waste stream, the wastewater exiting the system may still contain levels of organic materials that are too high for disposal, depending on environmental standards in place. If needed, additional treatment systems should be installed to ensure project compliance with environment regulations.

Financial institutions need to confirm that the developer is aware of environmental regulations and has taken appropriate measures to be in compliance.

6.4 FURTHER INFORMATION

GTZ (German Agency for Technical Cooperation). 2010. "Agro-Industrial Biogas in Kenya, Potentials, Estimates for Tariffs, Policy and Business Recommendations." <http://www.gtz.de/de/dokumente/gtz2010-en-biogas-assessment-kenya.pdf>.

Tanzania Domestic Biogas Programme, <http://www.biogas-tanzania.org/>.

UNDP (United Nations Development Programme). 2000. *Bioenergy Primer: Modernised Biomass Energy for Sustainable Development*. <http://www.undp.org/energy/publications/2000/2000b.htm>.

UN-ESCAP (United Nations Economic and Social Commission for Asia and the Pacific). 2007. "Recent Developments in Biogas Technology for Poverty Reduction and Sustainable Development." <http://www.unapcaem.org/publication/F-Biogas.PDF>.

U.S. Department of Energy, Federal Energy Management Program (FEMP). "Biogas." <http://www.wbdg.org/resources/biogas.php>.

CHAPTER

7

Solar PV

This chapter provides the basic technical and financial details as well as key considerations for solar PV (SV) projects in Tanzania.

7.1

THE BASICS OF SV

7.1.1

CLASSIFICATION OF SV SYSTEMS: STAND-ALONE AND GRID-CONNECTED

Solar stand-alone systems (not connected to the grid) are common in Tanzania

SV panels convert the energy in sunrays into direct current (DC) electrical energy. SV power is commonly used in Tanzania in **stand-alone systems** (systems with a battery, that are not connected to the national grid). Examples of stand-alone systems include:

- **Solar home systems (SHS)** for household use are the most common. Rural households generally buy a solar system to be able to power lights, radio and TV, and charge mobile phones. In some remote villages of Tanzania, one can find up to five SHSs in a single village powering homes and small businesses such as entertainment pubs and small shops.
- **Solar lanterns** are the latest product in the SV market. The lanterns are simple plug and play gadgets intended to provide light (and sometimes charge a cell phone). Their main benefit is that they do not need to be installed.
- **Institutional SV systems** are also common in Tanzania, and are used to power mainly lights and refrigeration for off-grid public institutions, such as dispensaries, hospitals, or schools.
- **Commercial SV systems** in Tanzania are mostly used to provide electricity to off-grid tourist lodges, telecommunication towers, water-pumping systems, and electric fences.
- SV can also be used to power a larger number of households (for example, a village) with **SV-powered minigrids**, often in combination with a diesel generator (hybrid system). However, in Tanzania, SV minigrids are uncommon.

In addition, as per the SPPA, electricity generated with SV can be sold to TANESCO. **Grid-connected** SV systems are common in other parts of the world, but have not been installed in Tanzania so far. For example, Germany, front runner in grid-connected SV power, has more than 17,200 MWp of SV-installed capacity and has generated over 12,000 GWh of electricity in 2010—more than the total installed capacity of power systems in Tanzania from all sources.

Table 12 provides an overview of the different SV systems, stand alone and grid connected, their main use, and average power generation capacity.

Table 12: Overview of Existing Solar Energy and Potential Use in Tanzania

Classification	Main use	Capacity (average range)
Solar lantern	Household lighting	5 W
Solar home systems	Household	10–100 W
Commercial systems	Telecommunication towers, water-pumping systems, electric fencing	50–500 W
Isolated minigrids	Retail	500 W
Grid connected	TANESCO	>300 W

Source: Authors' compilation.

7.1.2

MEASUREMENTS: POTENTIAL CAPACITY AND ACTUAL ENERGY GENERATED

Installed capacity (measured in kW and MW)

The power capacity of an SV panel is measured as maximum power output under standardized test conditions. The maximum power measured is the nominal power of the module in watts peak (W_p).

All SV panels have a label stating the power generation capacity of the panel. Common sizes of panels are 10 Wp, 20 Wp, 50 Wp, and 100Wp. PV panels can be interconnected and be part of an SV system. The installed capacity of an SV system is expressed by the total number of installed panels multiplied by their rating. For example, two interconnected 50 Wp solar panels together equal one 100 Wp panel.

The actual power output of a solar panel at a particular point in time may be less than or greater than its standardized or "rated" value, depending on geographical location, time of day, weather conditions, and other factors.

Energy generated (measured in kWh, MWh, or GWh)

Output from SV power is variable because of the daily rotation of the earth, cloud cover, and of course the sun does not shine 24 hours per day. Weather conditions and ambient temperatures also affect the output of a solar panel. Most SV panels are most productive when touched by direct sunlight, under a 90 percent angle. In the rainy season, the system will generate less power because of indirect sunlight. Solar panels are also very sensitive to shading and dirt or dust on the surface of the panel. The panels therefore need to be cleaned regularly. Finally, the temperature of the solar panel also affects its efficiency. If the panel becomes very hot, its efficiency will decrease.

Tanzania has a high global solar radiation from 4–7 kWh/m²/day. As such, the country's conditions are highly suitable for SV power. Seasonal effects are limited because Tanzania is close to the equator. Still, the climate varies considerably within Tanzania. The potential energy generated will thus depend on the location-specific weather conditions and regular maintenance and cleaning of the modules.

For grid-connected systems, it is important that the grid is actually online at the time that the system wants to deliver its power to the grid. If there is a blackout, the grid cannot absorb the generated electricity and the power will be lost.

The annual actual energy generated from an SV system (see also box 20) is a function of:

- Total installed capacity (in kW or MW);
- Average hours of effective sunlight x 365, in Tanzania the average number of hours of effective sunlight ranges between 3 and 5.5; and
- System inefficiencies and transmission losses (a value between 0 and 1)—well-designed and maintained systems can be 80–90 percent efficient.

Worldwide there are various tools and Web sites that provide solar insolation data and can be used to estimate SV power output, such as:

- Solar Energy Mining database—a service providing solar radiation maps for Europe, Africa, western Asia, and parts of Australia and South America. http://wdc.dlr.de/data_products/SERVICES/SOLARENERGY/description.php.
- NASA-sponsored site on surface meteorology and solar energy that offers solar energy data for users of RETScreen software. <http://eosweb.larc.nasa.gov/sse/RETScreen/>.

Common sizes of panels are 10 Wp, 20 Wp, 50 Wp, and 100 Wp

PV panels can be interconnected and be part of an SV system

The output of a solar panel is mainly affected by:

- its geographical location;
- weather conditions;
- installation angle;
- shading; and
- dust

- RETScreen, an Excel-based project analysis tool for clean energy projects. <http://www.retscreen.net/ang/home.php>.
- Homer—modeling software for RE systems. <http://homerenergy.com/>.

Box 20: Application—Example of a Stand-Alone System

For an SHS with a 50 W panel, expected energy output can be estimated as:

- $50 \text{ W} \times 1,642 \text{ hours (4.5} \times 365) \times 85 \text{ percent} = 70 \text{ kWh/year}$

For a grid-connected system, the generation capacity of a 2 MW system could be estimated as:

- $2 \text{ MW} \times 1,642 \text{ hours} \times 85 \text{ percent} = 2,790 \text{ MWh/year}$

Source: Authors' illustration.

7.2

TECHNICAL SPECIFICATIONS OF AN SV SYSTEM

An SV system in Tanzania is generally used in a household or institution. As can be seen in figure 6, a **stand-alone SV system** generally includes the following equipment:

- Solar module (also called a panel or array);
- Battery—storing the generated electricity;
- Charge controller—controls overcharging and deep discharging of the system battery, sometimes used as the central connection point;
- Inverter—converts DC electrical energy to alternating current (AC);
- Accessories (cables, clips, junction boxes, connectors, and so forth)—connect different parts of the SV system to ensure availability of electricity to a target point; and
- Electrical appliances—equipment using electricity generated (AC or DC).

Figure 6: Components of a Stand-Alone SV System

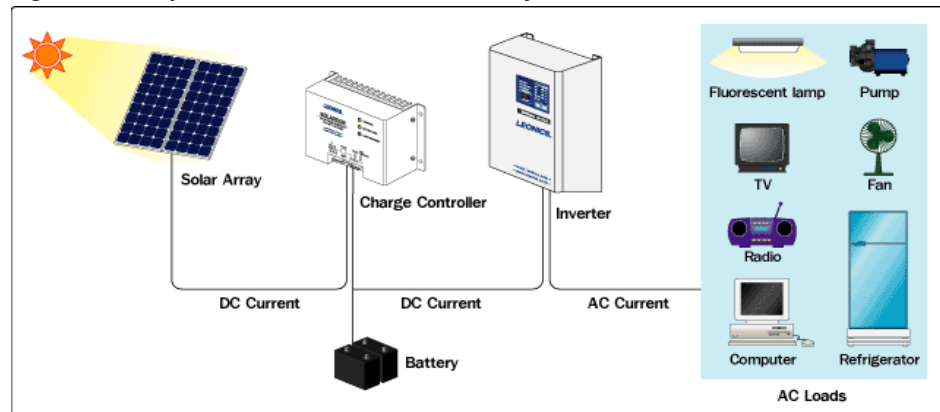

Source: <http://www.solarpower.org.in/>

Solar modules: Solar modules convert sunrays into DC electricity. The most common panels commercially available in Tanzania are crystalline SV modules and amorphous SV modules. Common brands of SV modules in East Africa include Suntech, Sharp, Kyocera, Solar World, and Schott.

Batteries: Batteries convert electrical energy into chemical energy and vice versa. The function of a battery in a SV system is to store energy, since the appliances (lights, radio, TV) are generally used after sunset. Battery capacity is rated in ampere hours (Ah). The two main types of batteries are acidic and alkaline. For SV systems, deep dischargeable batteries, sometimes also labeled solar batteries, are most suitable. The battery is often the weakest spot in the SV system and needs to be replaced every two to five years.

Battery characteristics include:

- Maintenance-free (sealed) battery packs, or batteries that require the user to regularly check and refill the battery with distilled water;
- Self-discharging when left without recharging for a long time (shelf-life limitations);

- Battery life is affected by deep discharge and overcharge; and
- Variable quality due to market availability.

Common brands of solar batteries in East Africa include Chloride Exide Solar, Dekka, Victron, BAE, Gaston, and Surrette.

Charge Controllers: Charge controllers protect the battery against deep- and overcharging. The electronics inside a charge controller normally use electrical power to function, so it should not be oversized unless necessary. Charge controllers are rated in amperes (A). Common brands of charge controllers in East Africa include Steca, Morningstar, Photon, and Phocos.

Inverters: The inverter converts DC power to AC power and is rated in watts. In an SHS, inverters are normally directly connected to a battery to protect the charge controller. In a grid-connected system, the inverter feeds the current into the grid.

There are different types of inverters and they are named after the type of waveforms they produce, such as the square wave, modified sine wave, and sine wave inverters. Not all electrical appliances can work with all types of the above inverters, except for sine wave inverters. It is good to know which type of inverters can handle the type of waves required by the target appliance. Some appliances have problems with specific types of inverters include hair cutting machines, VCRs, and printers.

Some of the common inverters for SV systems in East Africa include Victron Energy, Outback, Xantrex, Studler, and Steca. Low-quality inverters are also available. Besides being less reliable, low-quality inverters may be very power consuming and thus inefficient.

Grid-connected inverters are designed to match phase with a utility-supplied sine wave. Grid-tie inverters are designed to shut down automatically upon loss of utility supply for safety reasons.

7.2.1

BENCHMARK COSTS OF SOLAR EQUIPMENT IN TANZANIA

Table 13 provides current costs for SV system equipment for endusers in Tanzania and the United States. It should be noted that in recent years, the global prices of SV equipment have come down significantly.

Table 13: Comparison of Average Retail Prices of Solar Equipment in Tanzania and the United States

SV component	Tanzania (in US\$)	United States (in US\$)
SV modules	3.75–5.88 per Wp	2.42 per Wp
Batteries (12V57Ah, Gel-Deka)	0.273 per Wh	0.213 per Wh ^a
Batteries (12V100Ah, AGM)	0.182 per Wh	
Inverters (1,000W–1,500W)	0.77–0.95 per W	0.712 per W
Charge controllers 20A–30A	4.22–7.5 per A	5.93 per A

Source: United States' prices are from Solarbuzz (<http://www.solarbuzz.com>), Tanzania prices are from the Tanzania Traditional Energy Development Organization (TaTEDO; see chapter 2 for a description). The 0.213 per Wh price is an index price for solar batteries in general.

7.3

SOLAR OPPORTUNITIES IN TANZANIA

The Tanzanian solar industry has been growing steadily during the last decade, as shown by the increase in solar companies. While the number of such companies was less than 10 in 2000, in 2007 there were more than 20 companies, and in 2010 more than 50. These companies perform technical design and install larger SV systems. Small (14–20 Wp) systems are generally sold through rural independent shops and technicians, who travel to Dar es Salaam, Arusha, and Mwanza to buy their stock.

So far there are no specialized solar project developers in Tanzania. The financing demand mainly is from larger suppliers, who are the key players acting in the position of importers, wholesalers, and technical design and installation companies.



Photo: Tanzanian solar company in business

Although the SHS market is mainly driven by cash sales, there are a number of financial institutions providing financing to rural Tanzanians for solar products through group (for example, to women's' groups) and individual loans. These financial institutions include Akiba Commercial Bank, Finca Tanzania, and Tujijenge Tanzania. Companies like Umeme Jua and D-Light have piloted projects with microfinance institutions (MFIs) to lower the threshold for consumers purchasing a SHS. Some MFIs have negotiated a buy-back guarantee from the distributor.

Promotional projects to stimulate market development and to remove market barriers are ongoing, and include the World Bank Lighting Africa project, a Swedish International Development Cooperation Agency (SIDA)/Ministry of Energy and Minerals (MEM) project, and a United Nations Development Programme/Global Environment Facility/MEM project. Awareness of SV systems is increasing, especially in those areas with promotional projects and programs, including the Lake Zone and in coastal and northeastern Tanzania.

The World Bank is supporting an SV scheme, the Sustainable Solar Market Packages Project, which has been piloted in the Rukwa region. While electrifying social centers in Rukwa, contracted companies will also be able to develop their supply chains and technical base in the area.

7.4

KEY CONSIDERATIONS FOR SV PROJECTS

7.4.1

TRADE FINANCE

The need for commercial finance in the existing SV sector is mainly related to trade finance and enduser finance. For instance, many solar energy companies are in need of trade finance to finance imports of equipment and/or to finance rural stock. The commercial market for SV modules continues to grow. Providing credit in the form of a letter of credit or working capital finance to well-established SV trading companies could be considered.

7.4.2

ENDUSER FINANCE FOR SV

Enduser finance for SV projects is unlikely to be handled by larger financial institutions in Tanzania because project costs and financing needs are generally small (in the range of US\$200–US\$10,000). However, in the case of larger commercial systems or minigrid projects developed by communities of endusers, the need for finance is likely to exceed US\$50,000 and therefore may become feasible for a financial institution.

A number of key factors need to be considered when financing stand-alone SV systems. Table 14 identifies these key factors and provides guidance on possible mitigation of these project risks.

Table 14: Key Factors in Financing Stand-Alone SV Systems

Risk	Mitigation
Grid extension	Determine whether communities are likely to be connected to the grid.
Poor-quality, inefficient designs and equipment cause system breakdowns	<ul style="list-style-type: none"> Ensure technical system design is by highly qualified SV specialists aware of current best practices. Check if the initiative has consulted with off-grid SV specialists for an independent review. If the project entails many small systems, standardize to as few "building blocks" as possible. Contracts with SV suppliers should include detailed, technical specifications and strong certification, warranty, and commissioning conditions.
Procurement and implementation rollout delays	<ul style="list-style-type: none"> The developer needs to closely supervise equipment supply and installations. Confirm capacities and reputation of the importer/installation company.
System breakdowns due to inadequate maintenance and/or battery replacements	<ul style="list-style-type: none"> Secure firm commitments for recurrent budgets for maintenance and component replacements. For community systems, beneficiary participation in funding O&M is common. Check if the O&M structure has been defined. The project needs to decide on in-house or outsourcing maintenance and build local-service capabilities accordingly. Larger installations need to track SV system maintenance and performance to anticipate and address problems before failures occur. For SHSs, user will need to be trained on appropriate use and load management.
Theft and vandalism	<ul style="list-style-type: none"> Identify any security risks and mitigating measures. Consult with community and staff to create strong awareness and align expectations regarding sustainability of SV systems.
Adverse environmental impacts	<ul style="list-style-type: none"> Arrange recycling or disposal of light bulbs (for example, for compact fluorescent lamps or fluorescent tubes that use mercury) and lead-acid batteries.

Source: Authors' Compilation.

7.4.3

FINANCE FOR GRID-CONNECTED SV

Commercially funded solar minigrids and grid-connected projects have yet to be developed in Tanzania. However, since these types of projects are eligible under the SPP arrangement, they may be developed in the future.

Revenues

The SV power plant revenues are described in the chapter 3 (Project Finance). These revenues consist of energy sales to TANESCO (tariffs governed by the SPPA), revenues from retail sales, and possibly carbon credits.

Capital costs

The investment cost of a SV grid-connected plant in mature markets is generally around US\$5 million per megawatt of installed capacity.²⁵ In Tanzania, project costs are likely to be higher because there is no in-country experience yet and technical experts will need to be imported. Also, the cost of the system components (solar modules, inverters) is likely to be higher because of transport costs and lack of scale economies.

Operating costs

²⁵ The US\$5/watt figure is as reported by Altprofits in 2009

(<http://www.altprofits.com/ref/eco/eco.html>), see also chapter 3 of this manual. However, prices are coming down; in 2010, Zweibel reported a value of US\$3/watt for large, low-cost SV systems (http://solar.gwu.edu/Research/EnergyPolicy_Zweibel2010.pdf).

An SV grid-connected plant's cost structure follows the general structure outlined for RE projects in chapter 3. The most relevant operating costs are: O&M, administration, depreciation, taxation, and financial charges.

A solar plant's operating expenses tend to be relatively fixed, because costs for maintenance can be projected based on information from technology suppliers. High-quality solar modules and inverters have a long product life, with a warranty of 20 years on the output of the solar module and average warranty of 10 years on inverters.

7.4.4 MAIN RISKS AND MITIGATION TOOLS

Through 2010, procurement and implementation rollout delays were common in the SV market because worldwide demand exceeded production capacity.

The developer needs to thoroughly investigate the capacity and reputation of the importer/installation company and closely supervise equipment supply and installation.

Inefficient design and poor-quality equipment can cause system breakdowns and less-than-estimated outputs. The financial institution needs to ensure that the technical system is designed by qualified SV specialists. In mature SV grid-connected markets, specialized companies can be contracted to provide financial institutions with detailed feedback and projections on generation capacity of prospective SV projects.

Once operational, SV systems can become less efficient or may even breakdown due to inadequate maintenance. The majority of solar panels have warranty period of 20 years. The SV panels require regular cleaning to avoid dust or grease collecting on the modules. Single panels within the systems must be replaced if they break down.

Inverter performance in the SV system needs to be monitored and the O&M structure needs to anticipate and address problems before failures occur, because lead times for replacement components or new inverters can be very long. Today, most inverters have a warranty period of 10 years.

Fences and security measures can mitigate the risks of PV system theft and vandalism. Guards and cameras are also helpful, especially for SV modules installed on the ground (not mounted on top of a building or integrated into a building structure).

7.5 FURTHER INFORMATION

Zweibel, K. 2010. "Should Solar Photovoltaic Be Deployed Sooner Because of Long Operating Life

at Low, Predictable Cost?"

http://solar.gwu.edu/Research/EnergyPolicy_Zweibel2010.pdf.

Web sites:

- European Photovoltaic Industry Association, <http://www.epia.org/>
- Solarbuzz Solar Market Research and Analysis, <http://www.solarbuzz.com>

CHAPTER

8 Wind power

Wind power is the conversion of wind energy into a useful form of energy, such as using wind turbines to make electricity, windmills for mechanical power, wind pumps for water pumping or drainage, or sails to propel ships.

Wind energy for mechanical power to pump water is very common in some parts of Tanzania, mostly in the Singida, Dodoma, Shinyanga, Mara, and Rukwa regions. However, many of these systems are experiencing maintenance problems.²⁶ The use of wind power for milling and wood sawing is not common in most parts of the country.

This chapter focuses on using wind to generate electricity using wind turbines. Wind turbines convert the kinetic energy of wind into mechanical power. A generator can be used to convert the mechanical power into electricity to power homes, businesses, and to feed electricity into the grid.

8.1

THE BASICS OF WINDPOWER

Since the 1980s, when the first commercial wind turbines were deployed, their installed capacity, efficiency, and visual design have all improved enormously.



Horizontal axis turbine feeding power into the grid

Today, the vast majority of commercial turbines operate on a horizontal axis, with three evenly spaced blades. These are attached to a rotor from which power is transferred through a gearbox to a generator. The gearbox and generator are contained within a housing called a *nacelle*. Some turbine designs avoid a gearbox by using direct drive. The electricity is then transmitted down the tower to a transformer and eventually into the grid network.

Wind turbines can operate across a wide range of wind speeds—from 3–4 meters per second up to about 25 meters, which translates into 90 km per hour (56 mph), and would be the equivalent of gale force 9 or 10.

The majority of current turbine models make best use of constant wind variations by changing the angle of the blades through pitch control, by turning or “yawing” the entire rotor as wind direction shifts, and by operating at variable speed. Operation at variable speeds enables the turbine to adapt to varying wind speeds and increases its ability to harmonize with the operation of the electricity grid.

²⁶ For an overview, see Nzali and Mushi (2006).

8.1.1



Roof-mounted urban wind turbine charges a 12 volt battery and runs various 12 volt appliances within the building on which it is installed

CLASSIFICATION OF WIND POWER SYSTEMS

Wind turbines are available in a variety of sizes, and therefore a variety of power ratings. The largest machine has blades that span more than the length of a football field, stands 20 stories high, and produces enough electricity to power 1,400 homes. A small, home-sized wind machine has rotors between 2.5 and 7 meters in diameter, stands upward of 10 meters, and can meet the power needs of an all-electric home or small business. Utility-scale turbines range in size from 50 to 750 kW. Single, small turbines, below 50 kW, are used for homes, telecommunications dishes, or water pumping.

Wind turbines have also grown larger and taller. The generators in the largest modern turbines are 100 times the size of those in 1980. Over the same period, their rotor diameters have increased eightfold. The average capacity of turbines installed around the world during 2007 was 1,492 kW, while the largest turbine currently in operation is the Enercon E126, with a rotor diameter of 126 meters and a power capacity of 6 MW.

The majority of demand for larger capacity machines has been the offshore market, where placing turbines on the seabed demands the optimum use of each (expensive) foundation. For turbines used on land, however, the past few years have seen a leveling of turbine size in the 1.5 to 3 MW range (table 15).

Table 15: Classification of Wind Turbines

Classification	Main use	Capacity
Single, small turbines	Homes, telecommunications dishes, or water pumping	Below 50 kW
Utility-scale turbines or land	Connect to grid	750 kW to 3 MW
Offshore turbines	Connect to grid	3–6 MW

Source: Authors' compilation

8.1.2

WIND ENERGY MEASUREMENTS

Nameplate capacity (measured in kW, MW, or GW)

The “nameplate capacity” (or maximum potential power) of a wind power system is provided on the nameplate of the turbine. In practice, project developers rely on the quoted nameplate capacity and the number of production hours to calculate energy production.

Scientifically, however, the power of a wind turbine can be also calculated using the following formula: $P (W) = 0.5 \times \rho \times A \times v^3 \times C_p$, where,

- ρ = air density in kg/m^3 . Air density decreases with altitude and temperature. At sea level, at 15°C , air has a density of approximately 1.23 kg/m^3 ;
- A = swept area of the turbine blade in m^2 and is calculated as $\pi \times l^2$, where l = blade length;
- v = wind speed in m/s ;
- C_p = power efficiency factor—the power efficiency factor of a turbine at a given wind speed can be calculated as $C_p = \text{electricity produced}/\text{total energy available in the wind}$.

In theory, the highest possible efficiency factor (referred to as the Betz Limit) is 0.59. However, in practice, even in the best designed turbines, values around 0.35 are common. *Example:* A wind turbine has a blade length of 52 meters and a very high power coefficient of 0.40. Wind speed is given at 12 m/sec . Then, assuming an air density of 1.23 kg/m^3 , the turbine has a capacity of approximately: $0.5 \times 1.23 \times \pi \times (52)^2 \times (12)^3 \times 0.4 = 3.6 \text{ MW}$.

Wind turbine power curve

Figure 7 presents a wind turbine power curve specifying the relationship between power and wind speed. The curve shows that a turbine begins to produce power at a the minimum *cut-in speed* (depending on the turbine, this is usually around 3–4 m/s), and reaches nameplate capacity at its *rated speed*; for example, the rated speed is the minimum wind speed at which the turbine generates its rated power—usually this occurs at a speed of around 13 m/s . Finally, turbines also have a *cut-out speed*; the maximum

wind speed at which the turbine can be operated—usually turbines have a cut-out speed of around 25 m/s.

As shown in figure 7, at wind speeds between the cut-in speed and the rated speed, energy increases by the cube of wind speed. That is, if wind speed doubles from 6 to 12 m/s, power output increases eightfold. On the other hand, as also shown in figure 7, power does *not* significantly increase with wind speed after reaching the rated wind speed.

Figure7: Wind Turbine Power Curve

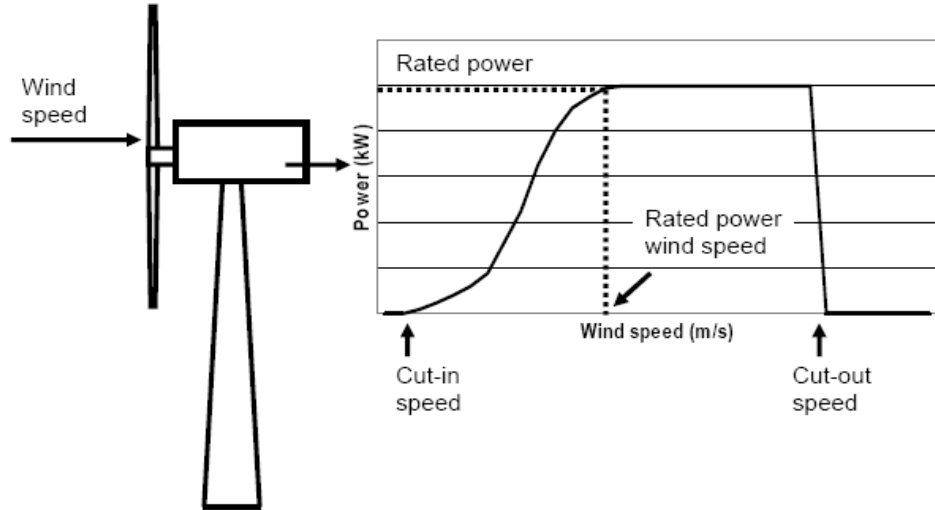

Source: Leonardo Energy (2008).

Wind speed distribution curve

Wind speed (obviously) is a key input for calculating capacity and expected energy generation. Therefore, having reliable wind speed data is of paramount importance. At the very least, a year’s worth of wind speed data are required for this purpose. With this information, one can draw a *wind speed distribution curve* (figure 8) that shows the number of hours the wind is blowing (on the y axis) per level of wind speed (on the x axis).

Figure 8: Wind Speed Distribution Curve

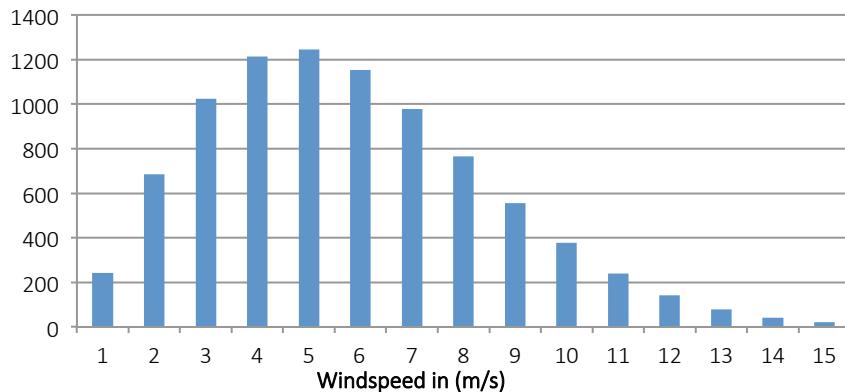

Source: Leonardo Energy (2008).

Level of energy generated (measured in kWh, MWh, or GWh)

The energy eventually generated by a wind turbine is usually determined by its nameplate capacity (as explained earlier) and the number of hours the turbine is in operation. In theory, if a turbine with a nameplate capacity of 3 MW was used continuously at full capacity, an energy output of 3 MW × 8,760 hours = 26,280 MWh could be realized.

However, in reality, a turbine is not used at full capacity continuously. If wind speeds are low, or too high, the turbine will be shut down. Another complicating factor is that at

different wind speeds, a different amount of power is generated (as visualized by the wind turbine power curve in figure 7).

Therefore, to calculate the total energy generated per year, one needs to know the number of hours the wind blows at various velocities throughout the year, as given by the wind distribution curve, and the capacity of the turbine at various velocities, as indicated by the wind turbine power curve. Then, the expected annual energy output can be calculated by multiplying the power of the wind turbine for each wind speed with the number of hours each wind speed is reached.

8.2

TECHNICAL SPECIFICATIONS OF WIND POWER SYSTEMS

Most large modern wind turbines are horizontal axis turbines. Depending on the desired power outputs, they include the following components:

- Blade or rotor, which converts the energy in the wind to rotational shaft energy;
- Low speed shaft, for transferring energy to gear box;
- Drive train, usually including a gearbox and a generator (for electricity generation);
- Tower, which supports the rotor and drive train; and
- Other equipment, including controls, electrical cables, ground support equipment, and interconnection equipment.

The most important component of the wind farm, in terms of technical performance, is the turbine. Well-known manufacturers of wind turbines in mature markets include Vestas, Enecon, Siemens, Nordex, General Electric, Suzlon, Vuurlander, and Repower.

Reputable suppliers typically offer a guarantee on turbine availability: the percentage of time a turbine can be online (and is not taken offline for maintenance or repairs). This availability guarantee is usually around 95 percent.

8.3

WIND POWER OPPORTUNITIES IN TANZANIA

In North Africa, the expansion of wind power continues in Morocco, the Arab Republic of Egypt, and Tunisia. Egypt not only saw the largest addition of new capacity in 2010 (120 MW), bringing its total up to 550 MW, but also continues to lead the region. Morocco comes in a distant second with a cumulative capacity of 286 MW, 30 MW of which were added in 2010. Tunisia added 60 MW of new capacity in 2010, taking the total up to 114 MW. Other promising countries in the region include Ethiopia, Kenya, Tanzania, and South Africa.

No reliable comprehensive wind map for Tanzania exists so far. Ongoing wind studies in the country have, however, revealed some potential sites for wind farms. As an example, wind data for the Singida region and Makambako in the Iringa region have revealed wind speeds of above 8 m/s, which is very promising for electricity generation. Other areas with wind speeds in excess of 4.5 m/s are Mkumbara, Karatu, and Mgagao.

Wind farms for commercial energy generation also appear promising in Makambako, Kititimo and Singida (feasibility studies exist), as well as in Mkumbara, Karatu, and Mgagao. Wind resource measurements in other promising areas are being planned and include the Rift Valley in Rukwa, Livingstone Mountains, Mafia Island, and Shinyanga.

In Tanzania, the current technical capacity for wind power is limited but growing. There are a few actors in the private sector involved in wind energy. Private sector players involved in wind energy projects of over 50 MW include Power Pool East Africa and Wind East Africa. Wind East Africa was the first Tanzanian wind energy firm to be granted a license by the EWURA to produce energy.²⁷ In addition, research efforts are underway in academic institutions.



Wind is plentiful, but under-exploited in central Tanzania

Wind data for Singida region and Makambako in Iringa Region have revealed wind speeds of above 8 m/s

²⁷ Wind East Africa was granted a license to install a 100 MW project. For video of the announcement on national television, see <http://www.youtube.com/watch?v=S3OGGqo3III>.

In the near future, more players may appear on stage because the REA intends to put more effort into the development of small wind turbines. To start, the REA recently advertised a tender for wind resources mapping.

In fact, small wind turbines are currently emerging throughout the country. For example, NGOs such as TaTEDO, “I Love Windpower,”²⁸ and the Tanzanian Wind Energy Association started installation of Hugh Piggott wind turbines. These small turbines, which have a peak power of up to 1 kW, can be built from locally available materials and, after training, be installed by local communities. The turbines have the capacity to produce 350 W, 800 W, or 1,000 W. According to TaTEDO, the installation costs are around US\$3,000 per turbine.

8.4 KEY CONSIDERATIONS FOR WIND POWER PROJECTS

When reviewing a wind power project, the main issues specific to wind power can be grouped in three categories, which are discussed in more detail in the sections below:

- Technology and project development;
- Wind speeds; and
- Investment costs and revenues.

8.4.1 TECHNOLOGY AND PROJECT DEVELOPMENT

Financing of a wind power project typically involves:

- Project sponsor (for example, government and consortium);
- Construction contractor (EPC);
- Supplier (for example, wind turbine equipment provider); and
- O&M.

To mitigate risks during construction and operation, contractual arrangements and associated guarantees with the supplier and the construction contractor need to be in place. Risks related to delays in equipment delivery also need to be taken into account. While equipment suppliers today can generally deliver products in the same year that they are ordered, transport of bulky and heavy turbines and large blades to rural or remote regions of Tanzania can be complicated and costly (for example, new roads may need to be constructed).

To mitigate technology risk, it is important to have the project assessed by an expert third party. In mature markets, the lender contracts a technical consultancy firm specialized in assessing wind farm project proposals.

8.4.2 WIND SPEEDS

Wind speeds fluctuate, and in some regions can be seasonal. A project proposal needs to include suitable wind resource data and analysis, including information on average wind speeds, consistency of wind speeds, (seasonal) fluctuations, and an uncertainty analysis collected over a multiyear period. The analysis needs to feed into a power generation projection.

The wind speed measurement process should account for surface roughness at measuring sites and measure speed at heights in excess of 30 meters. To assess whether wind speeds have been measured in accordance with standards and have been accurately incorporated into project wind yield expectations, the lender should engage an expert on wind yield studies.

8.4.3 INVESTMENT COSTS AND REVENUES

It is challenging to provide benchmark figures on investment costs. However, as an indication, wind farm project costs can be estimated at US\$1.5 to US\$2 million per megawatt for onshore wind farms, and US\$ 2.5 to US\$3 million per megawatt for offshore farms.

²⁸ <http://www.i-love-windpower.com/cms/>.
Reference manual

Additional costs, such as construction of additional transmission lines and costs of connecting to the main grid, are not included in this cost projection.

8.5

FURTHER INFORMATION

Kainkwa, R. R. M. 2002. "The Status of Wind Energy Development in Tanzania." *Physica Scripta* T97.

Leonardo Energy. 2008. "How to Manual: Small Scale Wind Energy Systems." <http://www.leonardo-energy.org/files/root/pdf/2008/How%20to%20Wind%20Energy.pdf>.

Nzali, A. H., and S. J. S. Mushi. 2006. "Wind Energy Utilization in Tanzania." http://public.ises.org/PREA/3_Papers/5_Wind_Energy_Technologies_TZ_Nzali.pdf.

TaTEDO. 1998. "Wind Energy Study." Study commissioned by the Royal Danish Embassy in Tanzania. <http://tatedo.org/cms/images/researchdocs/windenergy.pdf>.

Intelligent Energy–Europe. "Wind Energy—The Facts (WindFacts)." European project financed by the Executive Agency for Competitiveness and Innovation, November 2007 to October 2009. <http://www.wind-energy-the-facts.org>.

Royal Academy of Engineering. Undated. "Wind Turbine Power Calculations." http://www.raeng.org.uk/education/diploma/maths/pdf/exemplars_advanced/23_Wind_Turbine.pdf.

Web sites:

- I Love Windpower, <http://www.i-love-windpower.co>.
- World Wind Energy Association, <http://www.wwindea.org>.



THE WORLD BANK



SWEDEN