

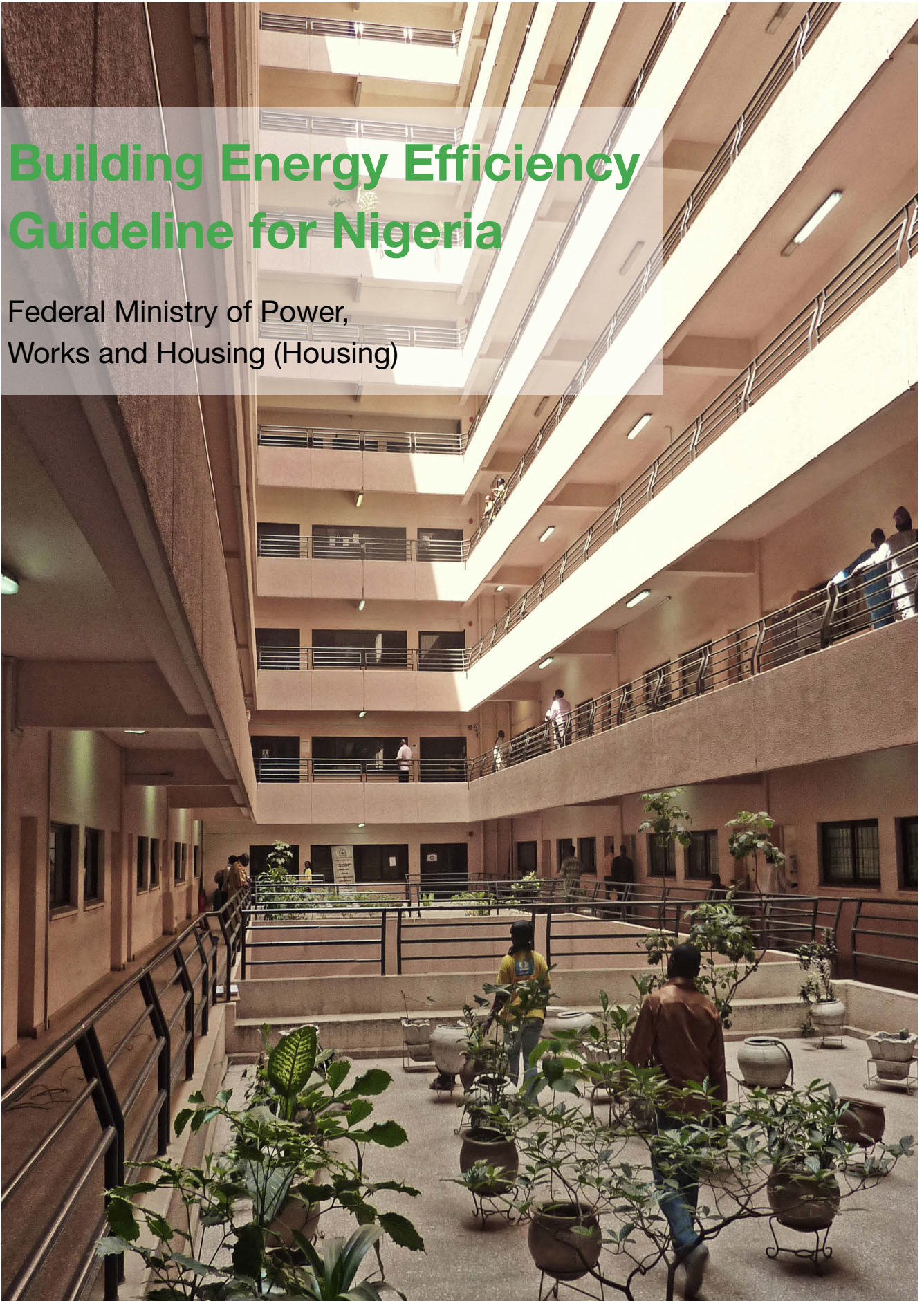

# Building Energy Efficiency Guideline for Nigeria

Federal Ministry of Power,  
Works and Housing (Housing)





# **Building Energy Efficiency Guideline for Nigeria**

Federal Ministry of Power,  
Works and Housing (Housing)

**Published by:**

Federal Ministry of Power, Works and Housing (Housing)  
Shehu Yar'adua Way, Mabushi  
Abuja, Nigeria.

**Supported by:**

Nigerian Energy Support Programme (NESP)  
Deutsche Gesellschaft für  
Internationale Zusammenarbeit (GIZ) GmbH

2 Dr Clement Isong Street, Asokoro  
Abuja, Nigeria  
Contact: Ina Hommers (ina.hommers@giz.de)  
t: 00234 (0)8054601986

This project is funded by the European Union  
& the German Federal Ministry for Economic Cooperation  
and Development (BMZ)

**Authors:**

Arup (Madrid & Lagos offices)  
www.arup.com  
madrid@arup.com

Design Genre  
www.designgenre.com

**Contributors:**

Ene Macharm  
EE Advisor,  
Nigerian Energy Support Programme  
ene.macharm@giz.de  
**(Project Coordinator)**

Place and date of publication  
© Abuja, [June 2016]



**This document was produced with the financial assistance of the European Union.  
The views expressed herein can in no way be taken to reflect the official opinion  
of the European Union.**

---

# Table of Contents

List of Figures .....	vii
List of Tables .....	x
List of Acronyms .....	xi
Foreword .....	xii
Executive Summary .....	xiii
<b>01. INTRODUCTION TO ENERGY EFFICIENCY IN BUILDINGS .....</b>	<b>1</b>
1.1 Chapter Summary .....	1
1.2 Introduction .....	2
1.3 Energy Sources in Nigeria .....	2
1.4 Carbon Emissions from Energy Production in Nigeria .....	3
1.5 Energy Use per Sector .....	4
1.6 Energy Consumption In the Nigerian Building Sector .....	4
Office Energy Use .....	4
Benchmarks .....	5
Residential Energy Use .....	6
1.7 Energy Efficiency in the Nigerian Building Sector .....	6
<b>02. INTEGRATED DESIGN PROCESS:</b>	
<b>THE PROCESS OF PLANNING AN ENERGY EFFICIENT BUILDING .....</b>	<b>8</b>
2.1 Chapter Summary .....	8
2.2 Integrated Versus Conventional Design Process .....	9
2.3 IDP Framework: Nigerian Context .....	9
2.4 Principles of the Integrated Design Process .....	9
Build a Collaborative Team .....	11
Define the Energy Efficiency Targets .....	11
Define the Whole Life Cycle Budget for Project .....	12
Integrate Innovation, Synthesis and Decision Making .....	12
<b>03. ENERGY OBJECTIVES IN THE BUILDING SECTOR OF NIGERIA .....</b>	<b>14</b>
3.1 Chapter Summary .....	15
3.2 Introduction .....	15
3.3 Benefits of Energy Efficient Buildings .....	15
3.4 Energy Efficiency Objectives .....	15

3.5	Other Design Objectives . . . . .	15
	Design Liveable Buildings . . . . .	15
	Resilient Buildings . . . . .	16
	Economically Viable and Affordable . . . . .	16
	Encourage Renewable Energy Development . . . . .	17
<b>04.</b>	<b>BIOCLIMATIC BUILDING DESIGN: CONCEPTS . . . . .</b>	<b>18</b>
4.1	Chapter Summary . . . . .	18
4.2	Bioclimatic Design Approach . . . . .	18
4.3	Physics of Bioclimatic Design . . . . .	19
4.4	Climate Concepts . . . . .	19
4.5	Microclimate . . . . .	20
4.6	Thermal Comfort . . . . .	21
	Adaptive comfort . . . . .	23
<b>05.</b>	<b>BIOCLIMATIC ARCHITECTURE IN NIGERIA . . . . .</b>	<b>24</b>
5.1	Chapter Summary . . . . .	24
5.2	Nigerian Climate Characteristics . . . . .	25
5.3	Vernacular Architecture: Learning from history . . . . .	28
	Indigenous/Traditional . . . . .	29
	North Nigeria – Hot & Dry . . . . .	29
	Southern Nigeria – Hot & Humid . . . . .	30
	Tropical Architecture: Iconic Buildings and Architects . . . . .	30
	Contemporary Architecture . . . . .	31
	Bioclimatic design strategies for Nigeria. . . . .	31
	Objective 1: Minimising Heat Gains . . . . .	31
	Objective 2: Promoting Heat Loss . . . . .	31
	Site Selection and Orientation . . . . .	32
	Building Form and Geometry . . . . .	33
	Building Envelope . . . . .	35
	Strategies for Passive Cooling: Promote Heat Loss . . . . .	38
5.4	Summary of key strategies for hot & dry and hot & humid climates . . . . .	42
<b>06.</b>	<b>ACTIVE SYSTEMS . . . . .</b>	<b>44</b>
6.1	Chapter Summary . . . . .	44
6.2	Energy Efficient Vac Systems . . . . .	44
	Air Movement . . . . .	45
	Cooling Via Humidity Control . . . . .	45
	Efficient Cooling Systems . . . . .	45
	Other Vac Efficiency Measures . . . . .	46
6.3	Controls and BMS . . . . .	47
6.4	Energy Generation and Storage . . . . .	47

---

6.5	Energy Efficient Lighting and Equipment .....	48
	Lighting Design .....	48
	Artificial Light Sources .....	48
	Lighting Controls .....	49
6.6	Efficient Equipment .....	49
6.7	Metering .....	49
6.8	Commissioning .....	49
<b>07.</b>	<b>RENEWABLE ENERGY TECHNOLOGIES .....</b>	<b>51</b>
7.1	Chapter Summary .....	51
7.2	Renewable Energy (RE) Sources in Nigeria .....	52
7.3	Photovoltaic .....	52
	Future Trends For Decentralized Energy: Micro Grids .....	54
7.4	Solar Hot Water Systems .....	55
7.5	Wind Turbines .....	56
7.6	Bioenergy .....	56
<b>08.</b>	<b>REGIONAL HAZARDS AFFECTING BUILDING AND SYSTEMS DESIGN .....</b>	<b>58</b>
8.1	Chapter Summary .....	58
8.2	Regional Hazards .....	58
	Sand And Dust .....	58
	Condensation And Mold .....	58
	Heavy Rain .....	59
	Lightning .....	59
	Insects, Termites .....	59
	Security .....	59
<b>09.</b>	<b>TOOLS FOR DESIGNING ENERGY EFFICIENT BUILDINGS .....</b>	<b>60</b>
9.1	Chapter Summary .....	60
9.2	Whole Building Design Tools .....	60
9.3	Energy Efficiency Assessment Tools .....	63
	eQuest .....	63
	Energy Plus .....	63
	DesignBuilder .....	63
	Passive Haus Planning Package .....	63
<b>10</b>	<b>REGULATORY FRAMEWORK .....</b>	<b>64</b>
10.1	Chapter Summary .....	64
10.2	Legislation: Compliance and Enforcement Framework .....	64
10.3	Availability of Appropriate and Affordable Materials for Construction and Operation .....	66
10.4	Qualified Workforce for Energy Efficient Building Design, Construction and Operation .....	66

---

10.5	Quality Assurance .....	66
10.6	Market Demand for Energy Efficient Buildings .....	67
10.7	Access to Finance .....	67
10.8	Stakeholder Involvement and Acceptance – Moving Forward Together .....	67
10.9	International Experience – Network and Benefit .....	68
<b>11.</b>	<b>SUSTAINABILITY CERTIFICATION .....</b>	<b>69</b>
11.1	Chapter Summary .....	70
11.2	Introduction .....	70
11.3	Green Building Council of Nigeria (GBCN) .....	70
11.4	Sustainable Buildings Certification Systems .....	71
	BREEAM .....	71
	LEED .....	71
	Green Star .....	71
	Passivhaus .....	71
	EDGE .....	71
<b>12.</b>	<b>CASE STUDIES: ENERGY ANALYSIS OF BUILDINGS IN NIGERIA .....</b>	<b>72</b>
12.1	Chapter Summary .....	72
12.2	Introduction .....	72
12.3	Variants Definition .....	73
12.4	Source of Building Data .....	73
12.5	Source of Cost Data and Procedure of Economic Assessment .....	73
12.6	Simulation Tool .....	73
12.7	Results Format .....	74
12.8	Case Studies Analysis .....	74
	Bungalow .....	74
	Multi-unit apartment building .....	78
	Office building: small office .....	81
	Office building: large office .....	84
12.8	Conclusions .....	86
	<b>REFERENCES .....</b>	<b>89</b>
	<b>APPENDICES .....</b>	<b>92</b>
A.	Breakdown of Measures Adopted for each Variant Simulation and Estimated Added Costs .....	92
B.	Methodology for Carbon Calculations .....	104
C.	Organisations Represented in Workshops organised for the development of the BEEG .....	106



---

# List of Figures

<b>Figure 1</b>	Efficient building approach . . . . .	2
<b>Figure 2</b>	Historical total energy supply in Nigeria (Mtoe) . . . . .	2
<b>Figure 3</b>	Carbon intensity of different fuel types . . . . .	3
<b>Figure 4</b>	Nigerian Electricity Consumption (million kWh). . . . .	4
<b>Figure 5</b>	Energy Use Intensity of office buildings in London and in South Africa . . . . .	5
<b>Figure 6</b>	Typical household annual energy consumption.. . . . .	6
<b>Figure 7</b>	Estimated breakdown of energy use in middle income and high income households . . . . .	6
<b>Figure 8</b>	Integrated Design Process. . . . .	10
<b>Figure 9</b>	IDP team for residential building project . . . . .	11
<b>Figure 10</b>	IDP team for office building project . . . . .	12
<b>Figure 11</b>	IDP: Project stages and team involvement. . . . .	13
<b>Figure 12</b>	Benefits of energy efficient buildings . . . . .	15
<b>Figure 13</b>	Liveable buildings performance metrics . . . . .	16
<b>Figure 14</b>	BedZED community development . . . . .	17
<b>Figure 15</b>	Energy efficiency strategy. . . . .	18
<b>Figure 16</b>	Faculty of Social Sciences, Obafemi Awolowo University. . . . .	18
<b>Figure 17</b>	Climate parameters . . . . .	20
<b>Figure 18</b>	Urban microclimate factors . . . . .	21
<b>Figure 19</b>	Human heat balance mechanisms . . . . .	21
<b>Figure 20</b>	Human Comfort Parameters . . . . .	22
<b>Figure 21</b>	Adaptive Comfort Chart. . . . .	23
<b>Figure 22</b>	Design for cooling: basic strategies, site selection & orientation . . . . .	24
<b>Figure 23</b>	Climate Zones in Nigeria. . . . .	25
<b>Figure 24</b>	Minimum and maximum temperatures in Nigeria. . . . .	26
<b>Figure 25</b>	Climate data for Warri. . . . .	27
<b>Figure 26</b>	Climate data for Lagos. . . . .	27
<b>Figure 27</b>	Climate data for Sokoto. . . . .	27
<b>Figure 28</b>	Climate data for Nguru . . . . .	27
<b>Figure 29</b>	Mean Temperature, Humidity and Integrated Effective Temperature index for Nigeria . . . . .	28

<b>Figure 30</b>	Typical roof construction with palms. . . . .	29
<b>Figure 31</b>	Sample of sun dried clay bricks. . . . .	29
<b>Figure 32</b>	Kano City Mud Wall. . . . .	29
<b>Figure 33</b>	Bioclimatic strategies in typical urban buildings: Shading and natural ventilation.. . . .	31
<b>Figure 34</b>	Sequence of bioclimatic strategies . . . . .	31
<b>Figure 35</b>	Sun path for Kano, Nigeria. . . . .	32
<b>Figure 36</b>	Annual incident radiation for Kano, Nigeria. . . . .	32
<b>Figure 37</b>	Courtyard strategy. . . . .	34
<b>Figure 38</b>	Natural Ventilation Schemes. . . . .	34
<b>Figure 39</b>	Exterior shading strategy. . . . .	35
<b>Figure 40</b>	High thermal mass concept and interlocking stabilised soil blocks. . . . .	39
<b>Figure 41</b>	Green wall system (Frankfurt). . . . .	40
<b>Figure 42</b>	Evaporative coolign tower. . . . .	41
<b>Figure 43</b>	Psychometric charts outlining thermal comfort hours with the main passive strategies outlined . . . . .	43
<b>Figure 44</b>	De-humidification Systems . . . . .	45
<b>Figure 45</b>	Evaporative Systems . . . . .	45
<b>Figure 46</b>	Closed cell elastomeric foam insulation which offers good vapour performance as well as thermal insulation . . . . .	47
<b>Figure 47</b>	BMS interface for controlling temperature set point etc., and simple time clock . . . . .	47
<b>Figure 48</b>	Small petrol generator and various battery options . . . . .	47
<b>Figure 49</b>	Lamp types . . . . .	48
<b>Figure 50</b>	Lamp types and their efficiencies . . . . .	48
<b>Figure 51</b>	PV panels, solar hot water heaters and small wind turbines. . . . .	52
<b>Figure 52</b>	Global horizontal solar radiation in Nigeria. . . . .	52
<b>Figure 53</b>	Flooded deep discharge lead-acid battery bank feeding three SMA Sunny Island inverter/chargers. . . . .	54
<b>Figure 54</b>	Thermosyphon system . . . . .	55
<b>Figure 55</b>	Closed-loop active systems . . . . .	55
<b>Figure 56</b>	Solar Water Heating Systems . . . . .	55
<b>Figure 57</b>	Air source heat pump used to heat domestic water. . . . .	56
<b>Figure 58</b>	Darling Wind farm, South Africa . . . . .	56
<b>Figure 59</b>	Firewood sourcing . . . . .	57
<b>Figure 60</b>	Biogas generator by Pioneer . . . . .	57
<b>Figure 61</b>	World lightning frequency map . . . . .	59
<b>Figure 62</b>	eQuest building model . . . . .	63
<b>Figure 63</b>	DesignBuilder model . . . . .	63
<b>Figure 64</b>	Energy Hierarchy and Energy Efficiency Strategy. . . . .	73
<b>Figure 65</b>	Typology of bungalows . . . . .	74
<b>Figure 66</b>	Bungalow BAU vs Variants . . . . .	75

---

<b>Figure 67</b>	Breakdown of electricity use in simulated bungalow . . . . .	76
<b>Figure 68</b>	Thermal comfort in bungalow under different climates . . . . .	76
<b>Figure 69</b>	Comparison between PV production in Variant and electricity consumption in Variant 2 . . . . .	77
<b>Figure 70</b>	Annual cost of grid electricity and fuel for generators in bungalow (₦/m <sup>2</sup> ). . . . .	77
<b>Figure 71</b>	Model of multi-unit apartment buildings . . . . .	78
<b>Figure 72</b>	Breakdown of electricity consumption in apartment block . . . . .	78
<b>Figure 73</b>	Model of multi-unit apartment BAU vs.Variants . . . . .	79
<b>Figure 74</b>	Thermal comfort in apartment block in different climates . . . . .	79
<b>Figure 75</b>	Comparison between annual PV production in Variant 3 and annual electricity consumption in Variant 2 . . . . .	80
<b>Figure 76</b>	Annual cost of electricity in apartment block (₦/m <sup>2</sup> ) . . . . .	80
<b>Figure 77</b>	Model of small office buildings . . . . .	81
<b>Figure 78</b>	Breakdown of electricity use in small office in hot & dry climate . . . . .	81
<b>Figure 79</b>	Breakdown of electricity use in small office in hot & humid climate . . . . .	81
<b>Figure 80</b>	Model of small office buildings BAU vs. Variants . . . . .	82
<b>Figure 81</b>	Comparison between annual PV production in Variant 3 and annual electricity consumption in Variant 2 . . . . .	83
<b>Figure 82</b>	Annual cost of energy (₦/ m <sup>2</sup> ) in hot & dry climate . . . . .	83
<b>Figure 83</b>	Annual cost of energy (₦/ m <sup>2</sup> ) in hot & humid climate . . . . .	83
<b>Figure 84</b>	Model of large office buildings . . . . .	84
<b>Figure 85</b>	Model of large office BAU vs. Variants . . . . .	85
<b>Figure 86</b>	Breakdown of electricity use in large office in hot & dry climate . . . . .	85
<b>Figure 87</b>	Comparison between annual PV production in Variant and annual electricity consumption in Variant 2 . . . . .	85
<b>Figure 88</b>	Annual cost of energy (₦/ m <sup>2</sup> ) in large office in hot & dry climate . . . . .	86
<b>Figure 89</b>	Annual cost of energy (₦/ m <sup>2</sup> ) in large office in hot & humid climate . . . . .	86
<b>Figure 90</b>	Energy efficiency measures implementation strategy . . . . .	88

# List of Tables

<b>Table 1</b>	Climate parameters in bioclimatic building design . . . . .	20
<b>Table 2</b>	Passive strategies applicability table . . . . .	25
<b>Table 3</b>	Hot & dry: vernacular architecture characteristics . . . . .	30
<b>Table 4</b>	Hot & humid: vernacular architecture characteristics. . . . .	35
<b>Table 5</b>	Lowest sun angle from horizontal to avoid all direct sunlight between 9am and 3pm . . . . .	36
<b>Table 6</b>	Visual and solar performance of a selection of typical glazing options (U values exclude window frame). . . . .	37
<b>Table 7</b>	Solar Reflectance Index (SRI) of common roofing materials . . . . .	38
<b>Table 8</b>	R and U values provided by DesignBuilder software . . . . .	38
<b>Table 9</b>	COP of Cooling Systems. . . . .	46
<b>Table 10</b>	Sample PV Systems . . . . .	53
<b>Table 11</b>	Overview of whole-building tools . . . . .	61
<b>Table 12</b>	Green and Energy Efficient design tools: Strengths and Weaknesses . . . . .	62
<b>Table 13</b>	Electricity consumption for lighting and in total in bungalow. . . . .	76
<b>Table 14</b>	Summary of Key results for bungalow . . . . .	77
<b>Table 15</b>	Electricity consumption for lighting and in total in apartments . . . . .	78
<b>Table 16</b>	Summary of key results for apartment building . . . . .	80
<b>Table 17</b>	Summary of key results for small office . . . . .	83
<b>Table 18</b>	Summary of key results in large office building . . . . .	86
<b>Table 19</b>	Typical envelope R and U values for the construction systems analyzed . . . . .	87
<b>Table 20</b>	Comparison between Variant 1 thermal envelope thermal performance and ASHRAE 90.1 2007 requirements . . . . .	87

---

# List of Acronyms

<b>AC</b>	Air Conditioning
<b>AHU</b>	Air Handling Unit
<b>AP</b>	Acidification Potential
<b>BAU</b>	Business as Usual
<b>BMS</b>	Building Management System (computerised VAC control system)
<b>BREEAM</b>	Building Research Establishment Environmental Assessment Method (UK)
<b>COP</b>	Coefficient of Performance
<b>DHW</b>	Domestic Hot Water
<b>EC</b>	Electronically Commutated
<b>ECOWAS</b>	Economic Community of West African States
<b>EE</b>	Energy Efficiency
<b>EUI</b>	Energy Use Intensity
<b>FFC</b>	Fossil Fuel Consumption
<b>FMPWH</b>	Federal Ministry of Power, Works and Housing (Housing)
<b>GBCA</b>	Green Building Council Australia
<b>GBCN</b>	Green Building Council of Nigeria
<b>GBCI</b>	Green Building Certification Institute
<b>GHG</b>	Green House Gas
<b>GIZ</b>	Deutsche Gesellschaft für Internationale Zusammenarbeit
<b>GWP</b>	Global Warming Potential
<b>HHC</b>	Human Health Criteria
<b>HHW</b>	Heating Hot Water
<b>IDP</b>	Integrated Design Process
<b>LEED</b>	Leadership in Energy and Efficient Design
<b>LED</b>	Light Emitting Diode
<b>MW</b>	Megawatt
<b>NESP</b>	Nigerian Energy Support Programme
<b>ODP</b>	Ozone Depletion Potential
<b>PV</b>	Photovoltaic System
<b>RE</b>	Renewable Energy
<b>SFP</b>	Specific Fan Power
<b>SWH</b>	Solar Water Heating
<b>USGBC</b>	United States Green Building Council
<b>VAC</b>	Ventilation and Air Conditioning
<b>VRV</b>	Variant Refrigerant Volume

# Foreword

Energy Crisis is a global phenomenon affecting all countries. Insufficient electricity generation coupled with increasing load demand has escalated the challenges of energy access and availability with the resultant effect on our country's socio-economic development.

The Federal Ministry of Power, Works and Housing (Housing) (FMPWH) in collaboration with the Nigerian Energy Support Programme (NESP) and relevant stakeholders in the building sub-sector have worked ceaselessly through meetings and workshops in putting together the building energy efficiency guideline. This document will serve as a reference to energy measures being taken that are relevant and appropriate for the Nigerian climate. It will also contribute to the global effort to combat climate change from the building sub-

sector by improving energy utilization efficiency, thereby resulting in socio-economic development of the country.

This guideline is technically divided into two parts: (i) Passive and (ii) Active elements on energy efficient building design. A well implemented building design strategy would provide comfortable conditions in buildings whilst reducing the building cooling demand and energy consumption.

Furthermore the guideline is expected to be a veritable guide to professionals in the building industry to plan, design and construct buildings that are energy efficient for the benefit of the environment and future generations.

**Engr. A.G. Magaji**

Permanent Secretary,

Federal Ministry of Power, Works and Housing (Housing)

---

# Executive Summary

This guideline was commissioned by the Federal Ministry of Power, Works and Housing (Housing) in collaboration with the Nigerian Energy Support Programme (NESP). It aims to give practical advice to professionals in Nigeria on how to design, construct and operate more energy efficient buildings. The guideline also aims to educate the general public about energy efficiency measures and provides clients with information that help them choose energy efficient buildings.

The guideline arises in response to the need to inform and create awareness on:

**What** the state of energy consumption in the building sector and the potential for improvement is.

**Why** energy efficiency is important and what energy efficiency goals should be set for Nigeria.

**How** energy efficiency can be implemented in the building sector in Nigeria.

The structure of the guideline responds to the above questions and is complemented by case studies where different building energy efficiency packages have been modelled and compared to identify optimal solutions for Nigerian climates. Simplifications were necessary in order not to exceed project resources and therefore, solutions have been tested for the two main climates: hot & dry (Northern Nigeria), and hot & humid (Southern Nigeria).

Nigeria faces a severe shortage of building stock with a 16 million housing deficit. For this reason this guideline concentrates on new buildings in the residential and office building sector rather than on improving existing buildings, although many of the solutions are equally relevant to existing buildings.

The analysis performed on various case studies of residential and office buildings highlights the relevance of implementing climate-adapted design strategies as primary measures for improving energy efficiency in buildings. The analysis, represented three different scenarios, the first scenario, where basic energy efficiency measures including bioclimatic design best practices such as improved building orientation, façade design, enhanced natural ventilation, efficient lighting and selection of insulating materials were included; an enhanced scenario where highly efficient façade and mechanical systems were added, and a third scenario where renewable systems were included.

The results showed that the first scenario comprising basic design measures already enabled very significant energy savings, these measures achieved energy consumption reductions of 40% at the very least which increased to 75% against the business as usual buildings when improved envelope and efficient systems were included. According to the results, the addition of PV panels could contribute to reduce electricity generation from fossil fuel sources. Renewable energy from PV panels could satisfy between 18% and 100% of the annual electricity demand. Although cooking energy is an important contributor to residential energy consumption, this guideline has not addressed this source of energy consumption since it is not related to building design.

Creating an energy efficient building starts with the right design approach, considering the specific microclimate conditions of the site, orientation and shaping the building form, a conscious selection of building materials and envelope systems aiming to minimise building heat gains. Following this, any active systems should be selected on the basis of high efficiency (e.g. highly efficient lighting systems) or to enable a reduction of cooling loads appropriate to the climate.



# 01 Introduction to Energy Efficiency in Buildings

## 1.1 Chapter summary

Energy efficient buildings are those which consume less energy while maintaining or even improving the comfort conditions for their occupants compared to standard buildings. Energy efficient buildings result not only in less environmental impact but are also economically sustainable and resilient.

The building sector accounts for the majority of electricity consumption in Nigeria and will inevitably increase significantly in absolute terms in the coming years driven by a rapidly increasing population, migration from low energy consuming rural dwellings to urban centres, and improvements in living standards. Set against a chronic

shortage of electrical generation and transmission capacity, energy efficiency measures represent the cheapest way of improving the state of energy supply in Nigeria now and in the future as the grid plays catch-up with demand.

This chapter provides an overview of the energy sector in Nigeria, its legislation and current policies, including the Renewable Energy and Energy Efficiency policies (2015), and the National Energy Efficiency Action Plan. It identifies what the current energy mix is, its environmental performance, and the breakdown of energy users in the economy. The principles behind the calculation of the EUI (Energy Use Intensity) measure (kWh/m<sup>2</sup>/year) are explained and referenced to international benchmarks.

Key findings	
<b>Statistics</b>	Households account for the large majority of electricity consumption (about 50%). Source: Energy Commission of Nigeria, 2014.
<b>Energy sources</b>	Energy in Nigeria is sourced from: <ul style="list-style-type: none"> <li>• 0.4% hydro</li> <li>• 17% oil/gas</li> <li>• 82% biofuel &amp; waste (mainly firewood)</li> </ul>
<b>Energy use in buildings and trends</b>	Energy consumed by buildings of interest in this guideline, medium-high cost residential and commercial, is mainly for cooling (e.g. air-conditioning units) and lighting. As Nigeria continues to develop, it is expected that energy use in the building sector will increase.
<b>Benchmarks</b>	Lack of reliable data for office and residential buildings makes it difficult to set local benchmarks in Nigeria. For a sub-tropical coastal climate, recent South African regulations set a maximum target of 190kWh/m <sup>2</sup> /year for office buildings.

## 1.2 Introduction

In Nigeria, energy consumed by the buildings targeted in this guideline (medium-high cost residential and commercial) is mainly due to cooling systems (e.g. air conditioning) and lighting. Energy consumed by residential buildings accounts for more than 50% of the total energy consumed in the country (Energy Commission of Nigeria, 2014). By using bioclimatic design techniques with highly efficient active systems, it is possible to greatly reduce the energy required to cool and light a building, or even in some cases eliminate the need for cooling entirely. This in turn reduces dependency on the grid electricity supply and helps improve energy security in the country.

Improving energy efficiency requires a different approach to the design and operation of buildings. It starts from the design methodology and goes through to the implementation of regulatory frameworks to allow and enforce EE targets. Education, dissemination and validation of the achievements of EE buildings could be provided by energy efficiency and sustainability certification schemes in conjunction with the Green Building Council of Nigeria (GBCN) and other relevant bodies. The resulting buildings will not only benefit from reduced energy consumption but will also provide a more comfortable internal environment for occupants, reduce the negative environmental impact, and be more economically sustainable and resilient.

This guideline analyses the current energy efficiency practices in the building sector and presents a design methodology and appropriate solutions for achieving more energy efficient residential and office buildings in Nigeria. Special attention

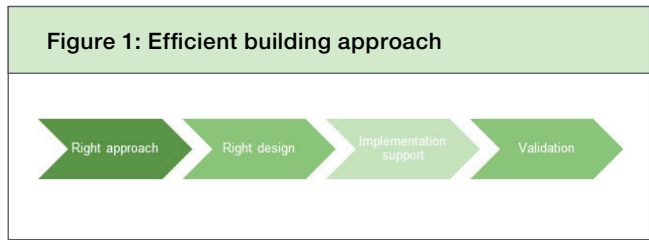

must be given to the fact that the switch to energy efficiency is strongly dependent on a shift in user behaviour to avoid profligate usage and wastage of energy. Users must understand that limiting the growth of electricity consumption will result not only in environmental and economic benefits, but also support energy security, reduce black outs, improve the accessibility to electricity for all, and boost the economic development of the country.

This Building Energy Efficiency Guideline is part of efforts that the FMPWH and NESP are taking to promote this shift by providing awareness and guidance to building design practitioners and users.

## 1.3 Energy Sources in Nigeria

Nigeria is Africa's largest oil producer and in 2012 was the world's fourth largest exporter of liquid natural gas (NESP, 2014). However, this production is currently exported, with only a fraction re-imported in refined form for use in Nigeria. In 2011, 159Mtoe of oil and gas were produced but only 20.5Mtoe consumed in Nigeria, accounting for 17.4% of Nigeria's raw energy consumption. Hydroelectric generation accounts for

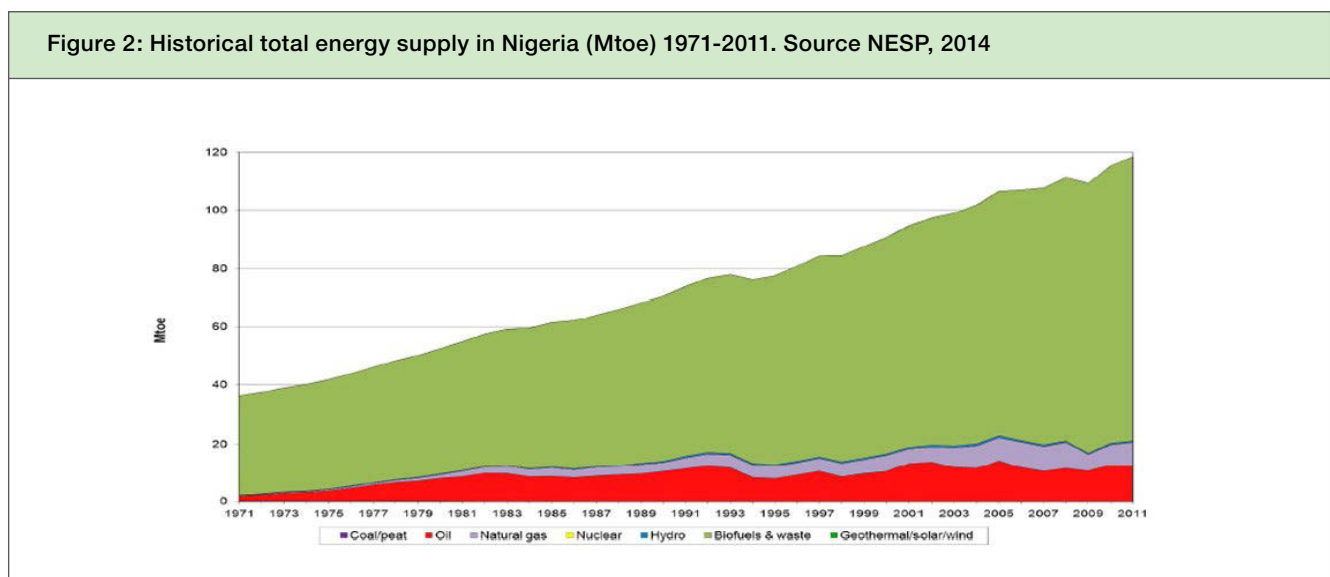

around 0.5Mtoe (0.4% of raw energy consumption). There are also reserves of coal although these have not yet been exploited on a large scale.

The remainder and large majority of energy used in Nigeria (82% in 2011) is biofuel and waste, mostly in the form of firewood burnt for cooking and heating water. As can be seen in Figure 2 above, over the last twenty years the amount of biofuel used has risen steadily while use of fossil fuels is relatively stable, presumably due to costs and poor infrastructure to deliver oil and gas to domestic users. This rate of firewood consumption far exceeds the replenishment rate, and is therefore unsustainable and leading to deforestation and desertification in many areas of Nigeria.

### 1.4 Carbon Emissions from Energy Production in Nigeria

It has now been formally recognised that many sources of energy generation are contributing to global warming via the release of pollutants. Carbon dioxide is the predominant Green House Gas (GHG) and thus, it is common to report on climate change inducing emissions in terms of carbon dioxide equivalent, which may be composed of other GHGs such as nitrous oxide and methane. Given the threat of climate change, the challenge of energy efficiency is not

just to reduce the number of kWh generated, but also to make sure that those kWh of energy have been generated at lowest cost to the environment.

The above graph shows typical carbon emissions for different fuel types. It illustrates, for example, that:

- Currently, using electricity for heating is generally inefficient in carbon terms, better to use gas or wood/ biofuel (but note concerns above regarding deforestation),
- Small petrol generators are a very inefficient way of generating electricity,
- Hydro-electric generation, photovoltaic (PV) and other renewable energy technologies are the cleanest methods of generating electricity.

1. <http://www.eia.gov/>. "CO<sub>2</sub> Emissions from Fuel Combustion (2012 Edition)", IEA, Paris. <http://www.iea.org/> Data for small petrol generators based on manufacturer's data with fuel consumption converted to emissions using United States Environmental Protection Agency (EPA) "Average Carbon Dioxide Emissions Resulting from Gasoline and Diesel Fuel"

**Figure 3: Carbon intensity of different fuel types (note figures differ depending on whether heat or electricity is being generated). Sources: US Energy Information Administration and International Energy Agency <sup>1</sup>**

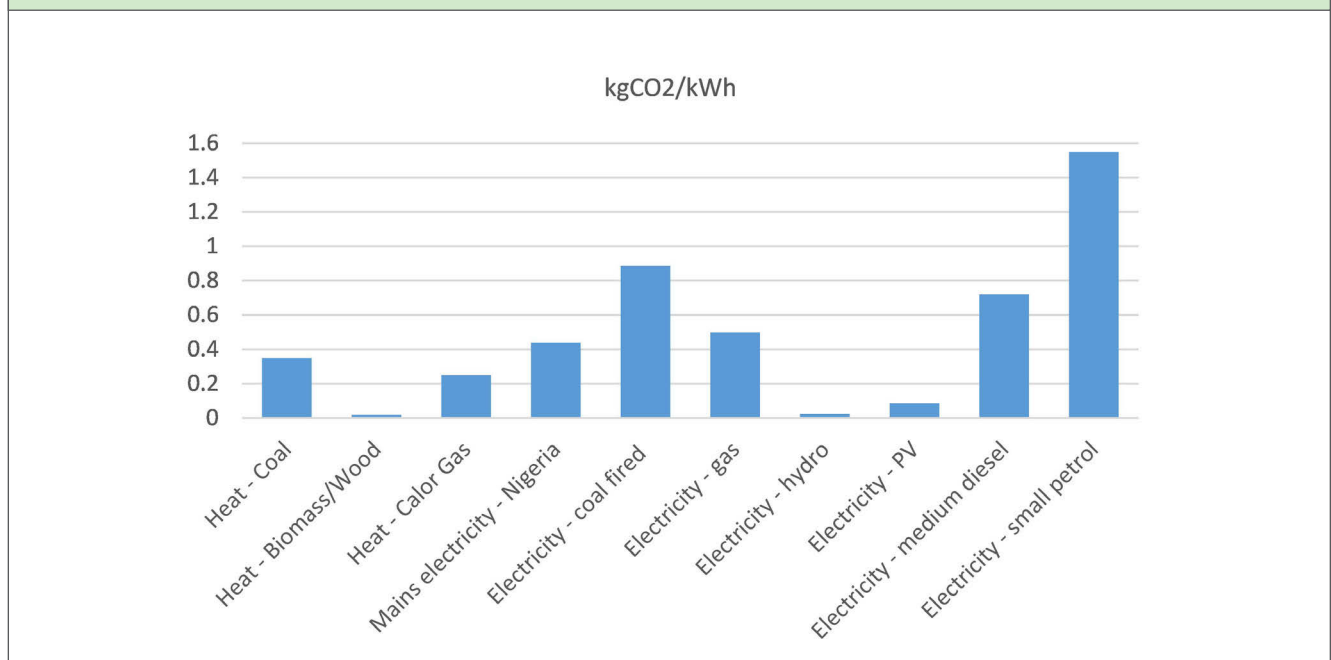

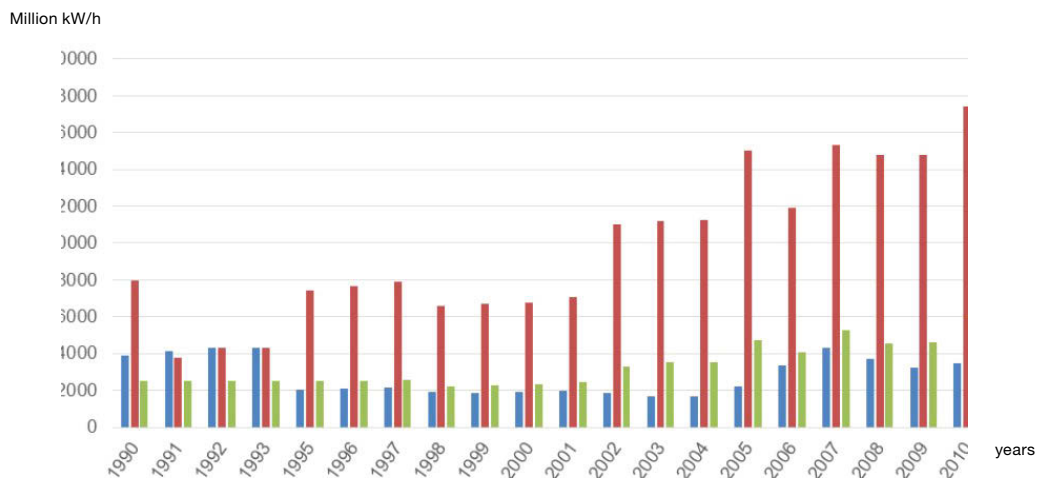
**Figure 4: Nigerian Electricity Consumption (million kWh). Source: NESP, 2013<sup>3</sup>**

## 1.5 Energy Use per Sector

Of the electricity generated in Nigeria, it is estimated that households account for the largest share of consumption (about 78%)<sup>2</sup>. This is a significant contrast with countries such as South Africa and Brazil where the majority is used in industry, and suggests that lack of power is hampering industrial growth in Nigeria.

An estimate of total energy consumption in Nigeria is challenging because a large percentage of the electricity consumed is generated on-site from private petrol/diesel generators. The World Bank estimates that the capacity of off-grid diesel and petrol generators totals 3GW and 1.3GW respectively. This is nearly equivalent to the total installed power plant capacity estimated at 6.2GW in 2011 (NESP, 2014). Due to fuel price rises and shortages, generating electricity with these small generators is not only inefficient in carbon emission terms, but also very expensive and unsustainable.

## 1.6 Energy Consumption in the Nigerian Building Sector

There is a shortage of reliable data on energy consumption in buildings, partly due to poor metering of mains electricity and also due to the fact that most buildings also generate electricity using petrol and diesel generators which complicates assessments.

In late 2014 the former Minister of Power, Professor

Chinedu Nebo estimated that 55% of Nigerian electricity users are not metered (Nebo, 2014). This is recognised as a major barrier to energy efficiency, and efforts are underway to ensure appropriate meters are installed.

### Office energy use

In 2013 GIZ commissioned a study on energy consumption in seven office buildings in Nigeria (NESP, 2013). The study suggested that office air-conditioning (VAC) accounted for 40-68% of electrical consumption, with the other important uses being lighting (13-37%) and office equipment (12-25%). This is probably fairly typical for an air conditioned office in Nigeria, although office equipment consumption will depend heavily on the number and type of computers and other equipment in the building.

The most common way of comparing building energy use is done by using the Energy Use Intensity (EUI) measured in kWh/m<sup>2</sup>/year. This can be calculated by collecting metered data on annual electricity consumption from the grid and/or

2. Note, the previous statistic stated that buildings accounted for 50% of energy use as opposed to electricity specifically.

3. The Nigerian Energy Sector – an overview with special emphasis on Renewable Energy, Energy Efficiency and Rural Electrification”, 2nd Edition June 2015, Nigerian Energy Support Programme (NESP) <https://www.giz.de/en/downloads/giz2015-en-nigerian-energy-sector.pdf>

Figure 5: Energy Use Intensity of office buildings in London (left) and in South Africa (right). Source: GBCSA, 2012

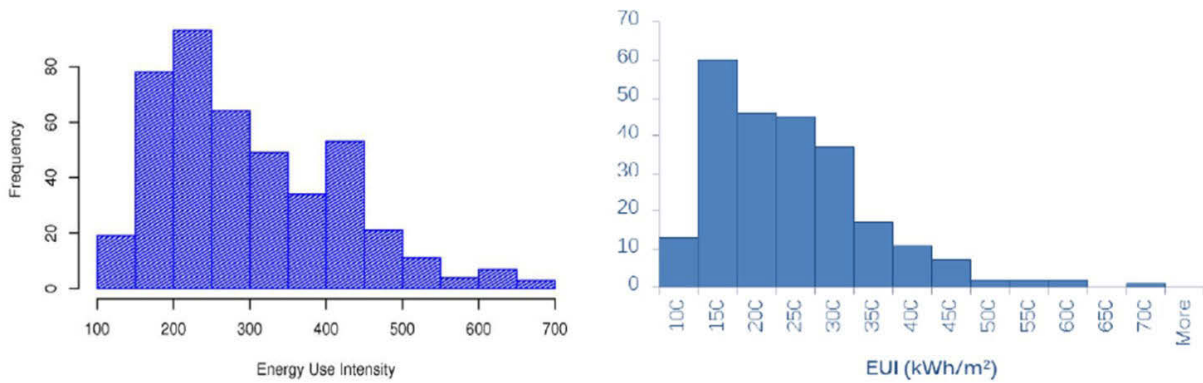

on-site generation (e.g. diesel generators or solar PV) and any other energy consumed (e.g. gas for cooking/water heating) and dividing by the internal floor area of the building. If the exact consumption of small generators are not known, then as an estimate a typical small petrol generator will produce around 1.5kWh of electricity per litre of petrol, while a larger diesel generator will produce around 3.7kWh of electricity per litre of diesel when running at the rated load. This is not a precise conversion since consumption varies significantly according to whether the generators are operating at full load or not. It is recommended that electricity sub-meters are fitted to generators to allow more precise monitoring.

The EUI has some disadvantages, such as penalising buildings which are densely occupied and not reflecting the source of the energy used, but is nevertheless the most widely used indicator for building energy use.

The above graphs show the distribution of EUI measurements in hundreds of office buildings in London and South Africa.

### Benchmarks

Benchmarks developed in South Africa where office construction is similar to Nigeria and where consumption of energy is mainly in the form of electricity, are as follows<sup>4</sup>:

- Under 130kWh/m<sup>2</sup>/year: best practice air conditioned office
- 130-210kWh/m<sup>2</sup>/year: good practice air conditioned office
- 210-320kWh/m<sup>2</sup>/year: typical existing air conditioned office
- Over 320kWh/m<sup>2</sup>/year: poorly performing air conditioned office

South African building regulation SANS 10400-XA introduced in 2011 have set a target that energy consumption of an office in the sub-tropical coastal climate should be no more than 190kWh/m<sup>2</sup>/year.

4. Data from (GBCSA/Arup, 2009)

**Figure 6: Typical household annual energy consumption. Source: NESP 2013<sup>5</sup>**

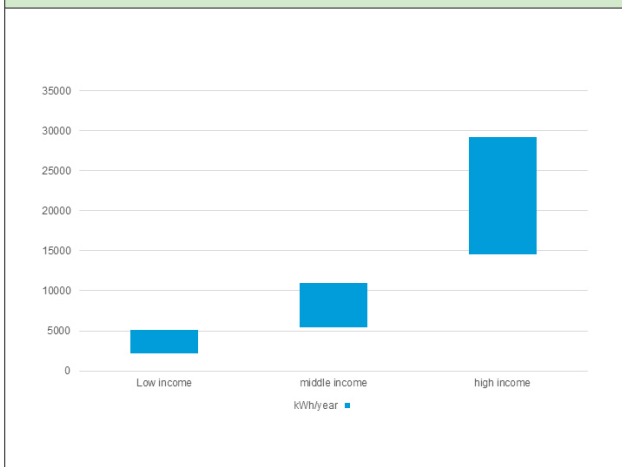

A survey commissioned by GIZ in 2013 covering 51 households in Minna and Abeokuta suggested the above range of electrical consumption (see Figure 7), with a breakdown as shown in the figure below (NESP, 2013).

The most significant difference between the high-income and medium-income households is the increase in energy used for ventilation and cooling, and the rise in the “others” (which includes computers, entertainment systems etc.). In comparison to similar studies in South Africa, the energy used for heating domestic hot water is very low. This may be due in part to difficulties in calculating the energy from firewood and kerosene, but also due to ambient temperatures being high, which means that many people wash in cool water. As Nigeria becomes more developed and thus aspirations for higher living standards are created, and if water availability improves, it is expected that hot water consumption will increase significantly.

**Residential energy use**

The use of the EUI (kWh/m<sup>2</sup>/year) for residential buildings is less common since the floor area is not necessarily correlated with occupancy. As such, a large energy inefficient house with few occupants may well have a better EUI than a small, efficient but densely occupied house, because the presence of more people increases cooling load and electricity consumption for electric appliances. It is, therefore, more common to use kWh/year for the household. However, for the purpose of this study the EUI was used because the building typologies modelled are very commonly constructed in Nigeria with typical occupancy patterns. Thus the EUI will prove useful in assessing the energy efficiency.

**1.7 Energy Efficiency in the Nigerian Building Sector**

In the past, the Federal Government of Nigeria made several policies in the energy sector that aimed to encourage uptake of renewable energy (RE) and energy efficiency (EE). However, these were limited in their scope and only mentioned general

5. “Energy Efficiency in Buildings (EEB) in Selected Sub-Sectors of the Nigerian Building Sector: Development of recommendations for interventions to promote energy efficiency in buildings” Dec 2013, Nigerian Energy Support Programme (NESP).

**Figure 7: Estimated breakdown of energy use in middle income (left) and high income (right) households**

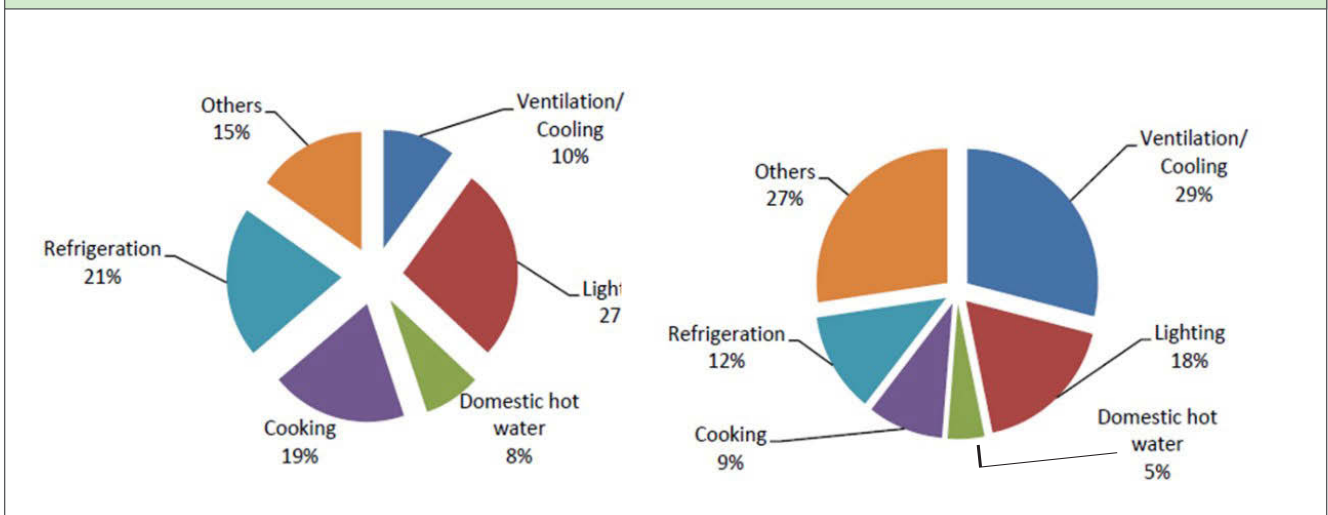

issues without giving a detailed framework. It is hoped that the recent approval of the first ever RE and EE policy for Nigeria will provide better guidance to the industry.

Within the building sector, this policy proposed developing energy efficiency building codes so that buildings are designed in line with bio-climatic design concepts and incorporate other energy saving measures.

A National Energy Efficiency Action Plan is currently being developed by stakeholders with the aim of promoting energy efficiency in Nigeria. This action plan supports the implementation of the recently approved RE and EE policy (2015) and sets its own targets for energy savings in the building sector amongst others and proposes concrete measures and actions that would contribute to meeting the targets.

The ECOWAS Directive on Energy Efficiency in Buildings (2013) also requires action from national governments to promote the improvement of energy efficiency of buildings.

The Nigeria National Building Code (2006) does not currently include detailed energy efficiency requirements, but is under revision to include those energy efficiency aspects that are easy to implement, cost-effective, and would lead to energy savings.

This Nigerian Building Energy Efficiency Guideline responds to the Nigeria RE and EE policy target of producing guidelines on all the key components of energy efficiency by 2020. The guideline provides practical information on the design and construction of energy efficient buildings, and will be disseminated to all major stakeholders in the construction industry.

# 02 Integrated Design Process: The process of Planning an Energy Efficient Building

## 2.1 Chapter Summary

Currently in Nigeria, building designs are usually developed using a linear and conventional design process. An architect is appointed and delivers a concept and scheme design with limited input from other specialists. Structural, Mechanical and Electrical engineers are appointed at the detailed design stage to provide their expertise in line with the design provided but have no role in shaping the design for optimisation in operation.

The design of energy efficient buildings is beyond the skills and expertise of only architects and, therefore, the integrated design process becomes an essential tool for the effective incorporation of expertise across different disciplines.

This chapter explores the Integrated Design Process (IDP) and what advantages it can offer to support the design of energy efficient and sustainable building projects.

### Key facts

#### IDP Process

The following steps help realise a successful project:

- Build a collaborative, open-minded team with communication skills.
- Draft the energy efficiency targets at an early stage.
- Use a whole life cycle approach when budgeting (i.e. taking into account operating costs as well as capital cost).
- Implement an iterative design process, including innovation, synthesis and decision-making based on the agreed objectives.



## 2.2 Integrated versus Conventional Design Process

The process of defining, designing and operating an energy efficient building requires a change in the mind-set and the way stakeholders are involved in the process.

“The Integrated Design Process (IDP) is a method for realising high performance buildings that contribute to sustainable communities. It is a collaborative process that focuses on the design, construction, operation and occupancy of a building over its complete life-cycle. The IDP is designed to allow the client and other stakeholders to develop and realize clearly defined and challenging functional, environmental and economic goals and objectives. The IDP requires a multi-disciplinary design team that includes or acquires the skills required to address all design issues flowing from the objectives. The IDP proceeds from whole building system strategies, working through increasing levels of specificity, to realize more optimally integrated solutions.” (Perkins+Will, 2001)

The IDP requires the integration of multi-disciplinary and collaborative teams whose members, from different perspectives, establish a common vision for the project, make decisions together and have a holistic understanding of the project. While the IDP addresses the entire project life, the major weight is set at the early stages of the project, when the vision and goals are defined, and when main barriers and constraints should be identified and integrated in the project.

The main characteristics of an IDP are:



The following diagram illustrates the differences between an IDP and a conventional design process (CDP):

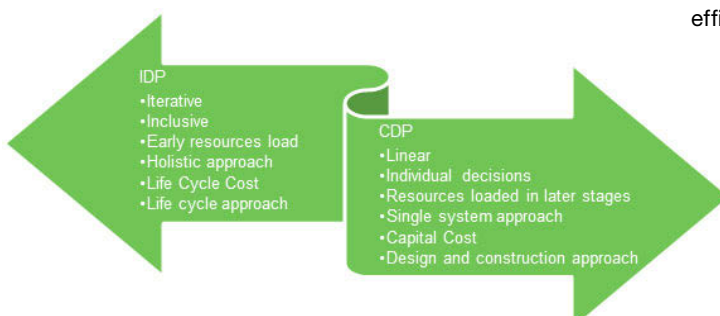

## 2.3 IDP Framework: Nigerian Context

Currently in Nigeria, designs are usually developed using the conventional route described above. Further complexities arise since consultant fees are often based on the value of the equipment that the consultant specifies, meaning that a mechanical engineer has a disincentive to try to reduce the amount of air-conditioning in a building.

In the context of the changes that the FMPWH in collaboration with the NESP are aiming for, the IDP could be used as a tool which would help professionals to develop specific energy efficiency objectives for buildings, identify barriers and opportunities, and set the design and operation strategies that would help to achieve these goals.

## 2.4 Principles of the Integrated Design Process

Sustainable design requires broader thinking and consideration of the environmental, social and economic impacts that each design decision will have today and in the future. When setting energy efficiency goals, the aim is to optimise the building’s performance and operational efficiencies at the lowest building cost. These are “win/win” cost trade-offs that can be identified through the design process. To succeed in this, the IDP established a set of principles that are the foundation to success. One of the most important principles is “effective and open communication” in recognition that a multi-disciplinary team cannot work together without communication (Perkins+Will, 2001). Strategies are suggested to achieve those principles and realise the benefits of the IDP.

The illustration overleaf outlines the mind-set, strategies, principles and subsequent benefits that constitute the IDP.

The following steps adapted from the IDP Roadmap (Perkins+Will, 2001) and the Green Schools resource Guide for Schools in Ontario (ZAS Architects+Halsall Associates, 2008) outline a road map to guide building professionals and stakeholders from inception to completion of an energy efficient building project.



### Build a collaborative team

A collaborative design team is critical for defining efficiency targets and integrating them into the developer's, design and budgeting objectives. The makeup of the design team should be adapted to each project depending on the opportunities and barriers to energy efficiency of the project in question. Nonetheless, the team should strive to have these traits:

- all members must be effective communicators,
- have a cooperative attitude, and
- be open-minded

The collaborative team should have an IDP integrator. The role of the IDP integrator is to maintain the focus and channel all contributions towards achieving the project target. The integrator can also be one of the experts contributing to design. In an IDP this role can be performed by the architect, or in some cases the green building specialist.

The core project team members need to include quantity surveyors and others able to assess the life cycle of the project. A common composition of the IDP team for the two building typologies analysed in this guide is presented below:

For more complex projects, additional members may be required and should be integrated into the team where necessary and encouraged to share their expertise. In small projects, one person will perform more than one task.

### Define the energy efficiency targets

Once the team is assembled, the energy efficiency objectives must be developed with input from key stakeholders.

An energy efficient building is that designed to minimise energy demand and provided with efficient equipment and materials appropriate for the location, use, and conditions, which is operated in such a manner that results in a low energy use when compared to other similar buildings (Meier & Thomas Olofsson, 2002).

The draft project objectives will be used to guide the design and construction phases of the project, enabling more effective decision-making when faced with design and construction choices. Well-defined objectives at the inception stage will reduce the need for changes and corrective actions, which can increase the capital and operation costs during the life cycle of the building.

Figure 9: IDP team for residential building project

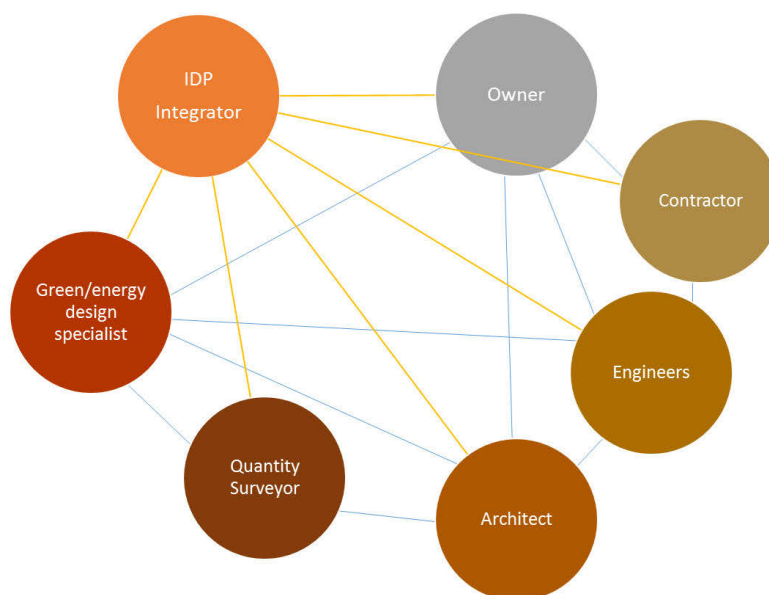
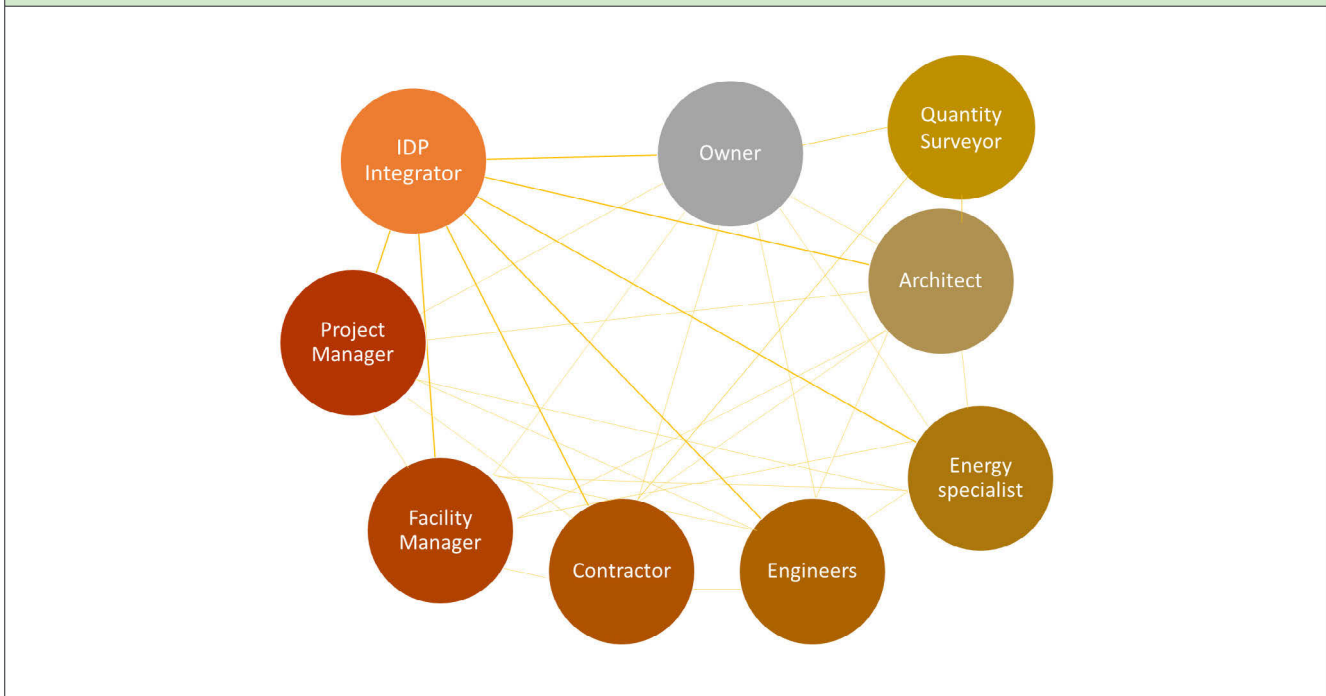

Figure 10: IDP team for office building project



### Define the whole life cycle budget for project

With a definition of the efficiency objectives in place, the next task is to set a whole life cycle budget that is over the entire life of the building. A project aimed only at saving construction costs will probably incur higher long-term operation and maintenance costs. The IDP team should consider a reasonable payback period for any premium over the base construction budget. This budget could be set based on previous experiences and benchmarks. Budgeting may also include non-monetary items, such as carbon emission reduction and water conservation.

### Integrate innovation, synthesis and decision making

Once the target whole life cycle budget (in both financial and non-financial terms) has been determined, the green objectives should be reviewed and specific strategies to achieve the targets discussed. A method of tracking and monitoring adherence to the green objectives should also be established at this point. The IDP team might want to consider the use of one of the many green building rating tools or develop its own tracking method. Regardless of the method, what is important is that the progress can be tracked and that any changes can be explained and understood by all the stakeholders while remaining flexible enough to

take advantage of unexpected synergies that may emerge through design and construction.

Another element is the inclusion of systems commissioning and training requirements in the operational phase, since a building's environmental performance is equally related to occupant behaviour and its operation. Proper commissioning, handover procedures, and operator training ensure that the environmental performance outlined in the design stage is not compromised in operation. A commissioning agent could be valuable as a member of the IDP team to witness the design and construction and to be on board to deliver the building as designed.

The figure below, adapted by Arup from the IDP Roadmap (Perkins+Will, 2001), shows team involvement along the lifespan of the project. As shown this may involve both focussed team workshops with specific experts as well as all team workshops for consultation with all IDP members on progress. Critical to this process is considering each decision as flexible so that it can accept numerous iterations. The same methodology of consultation should be maintained in the operational phase with operations workshops with the facility managers. Even at end of life, a workshop is encouraged to take decisions on the least environmentally damaging future for the building.

Figure 11: IDP: Project stages and team involvement. Source: Arup adaptation of the IDP process graph (Perkins+Will, 2001)

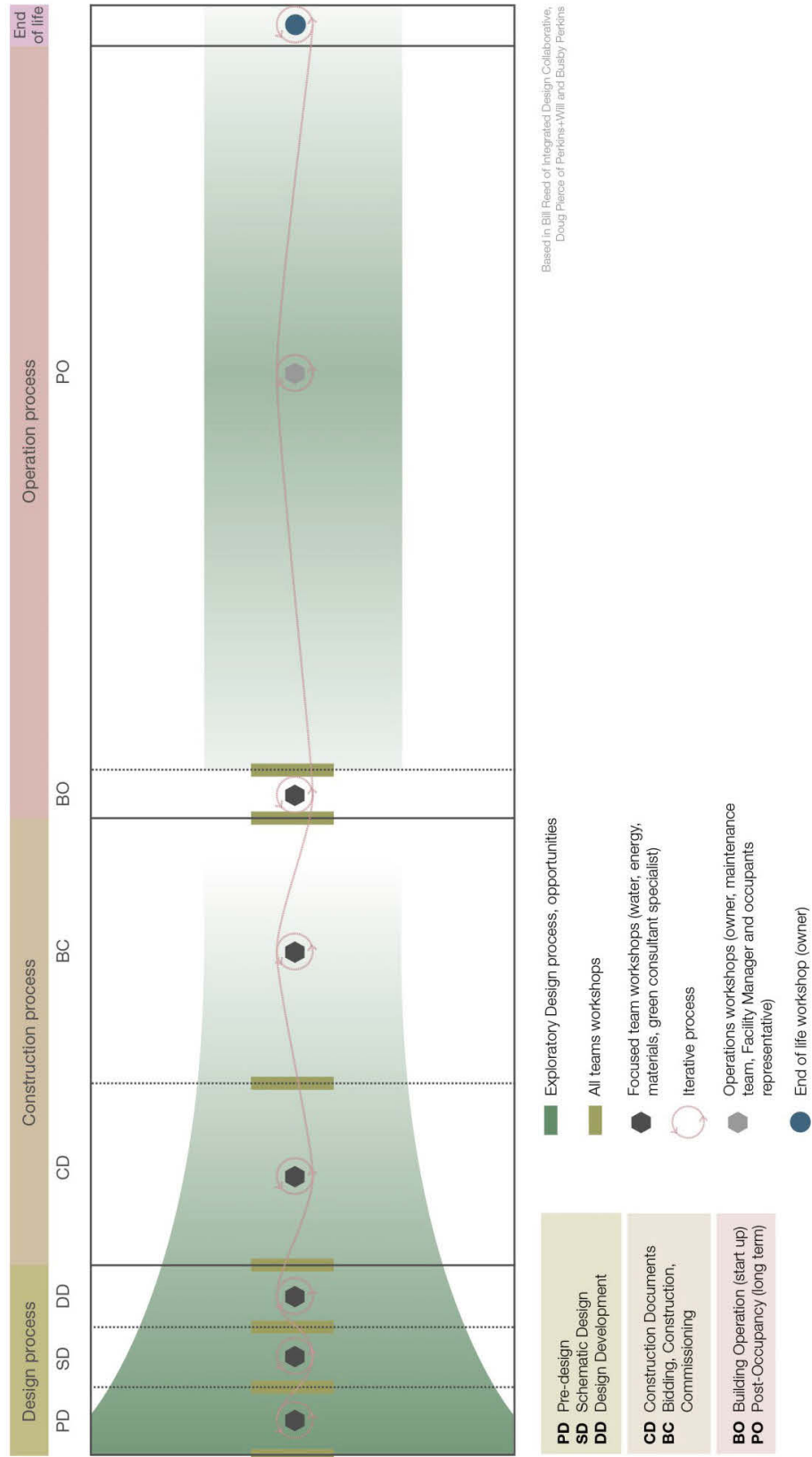

Based in Bill Reed of Integrated Design Collaborative, Doug Pierce of Perkins+Will and Busby Perkins

# 03 Energy Objectives in the Building Sector of Nigeria

Key findings	
<p><b>Building sector: Building Design Objectives</b></p>	<p>Energy efficiency in buildings is the main target, which goes hand-in-hand with the following objectives:</p> <ul style="list-style-type: none"> <li>• <b>Liveable buildings</b>, more comfortable and healthy</li> <li>• <b>Resilient buildings</b> and with reduced dependence on energy supply</li> <li>• <b>Economically viable and affordable buildings</b> with lower capital, operation and maintenance costs</li> </ul> <p>In addition, there is the objective to <b>encourage the development of the renewable energy sector</b>, in a country with very high renewable energy resources such as solar energy.</p>
<p><b>Energy Efficiency Strategy steps</b></p>	<p>The following hierarchy of steps is recommended:</p> <ul style="list-style-type: none"> <li>• <b>Minimise energy demand:</b> Through climate adaptive design (passive design) taking into account local conditions and microclimates</li> <li>• <b>Increase efficiency of systems:</b> Improving mechanical systems, appliances and lighting efficiency</li> <li>• <b>Cover remaining energy demand with renewable energy:</b> Given the large renewable energy capacity of the country, use renewable energy sources to substitute fossil fuel energy whenever possible.</li> </ul>

### 3.1 Chapter summary

This section outlines building energy performance objectives and suggests a general strategy for achieving these.

Improving energy security and reducing the environmental impact while maintaining or improving the comfort levels for building users are some of the major goals for the sector.

### 3.2 Introduction

Nigeria is faced with many challenges with regard to realising improvements in energy efficiency in buildings. Some of the major barriers are:

- lack of awareness and information on the benefits of EE measures in buildings
- inadequate policy, legal and regulatory frameworks
- lack of technical expertise
- lack of showcased energy efficient buildings to draw experience and inspiration from

On the other hand, the unreliable grid supply means that people are aware of energy issues and the high cost of power from small petrol generators makes energy efficiency measures more attractive.

### 3.3 Benefits of Energy Efficient Buildings

Energy efficient buildings have knock-on benefits in social and economic terms as well as environmental benefits as shown below.

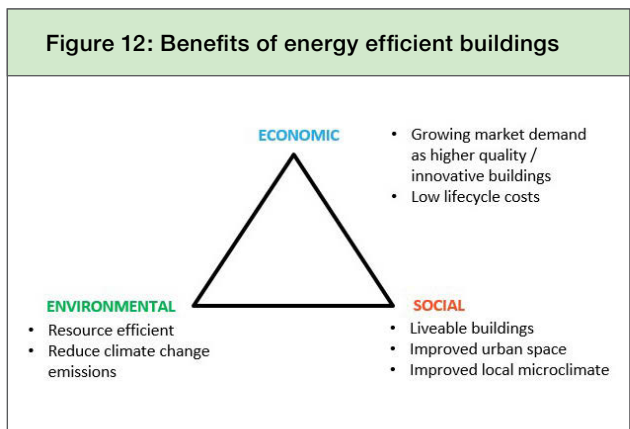

### 3.4 Energy Efficiency Objectives

In terms of energy efficiency, the main goal for the building sector is to achieve a demand reduction that can ameliorate the effects of urban development and poor grid infrastructure. The main strategies for achieving substantial energy demand reduction while maintaining and even increasing human comfort are based on the following:

- 1.** Bioclimatic architectural design to reduce energy demand. Bioclimatic design refers to architectural building design that seeks to optimize its performance by adapting the design to the local climate and achieve a more resource-efficient building. More information is provided in chapter 4.
- 2.** Planning energy efficient mechanical systems based on low demand. Alongside bioclimatic measures, active systems such as air conditioning may be required to guarantee the comfort of occupants. In keeping with the objective to be resource-efficient, energy efficient systems and appliances should be adopted where required. More information is provided in chapter 5.
- 3.** Covering the remaining energy demand (partly) by renewable energies. Once demand has been reduced by passive design and the necessary mechanical systems have been designed and selected to optimise their performance and efficiency, then renewable energy generation can add even more building performance. More information is provided in chapter 6.

### 3.5 Other Design Objectives

#### Design liveable buildings

Liveable buildings is a concept that focusses on creating living spaces designed for the comfort and health of the occupant. People spend a large part of their lives in buildings, whether their homes or offices, and it is critical that the spaces enhance their quality of life. Certain metrics of the interior building environment are key to ensuring a comfortable space, these metrics must be integrated with the energy efficiency goals. The figure below shows the main strategies for achieving comfortable and healthy buildings:

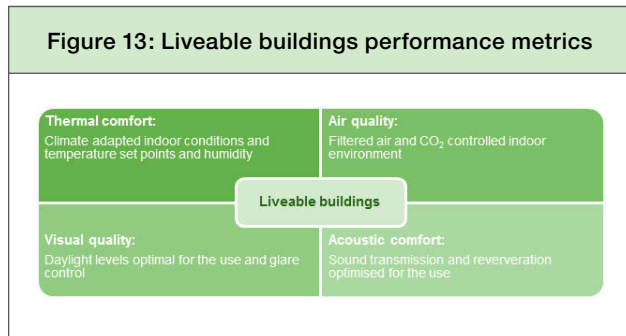

Resilience complements energy efficiency objectives in reducing the dependence of building systems on external commodities such as fuel for power generation. Less energy intensive buildings with the capacity to passively adapt to climate will be more resilient in a scenario of rising air temperatures due to climate change.

The need for healthy and comfortable spaces extends to the urban environment, i.e. outside the building envelope. The growing trend for green infrastructure in cities is attempting to restore the natural landscape in cities with trees and other vegetation which make it more attractive and healthy for dwellers. Vegetation plays an important role in natural CO<sub>2</sub> capture and storage.

**Resilient buildings**

“Resilience is described as the capacity to function and thrive no matter the shocks and stresses encountered. Resilience focuses on enhancing the performance of a system in the face of multiple hazards, rather than preventing or mitigating the loss of assets due to specific events.” (Arup, 2014)

Nigeria faces several challenges across the spectrum of environmental, social and economic realms. Notwithstanding the current electricity shortages and lack of energy security, climate change is predicted to exacerbate the situation through higher temperatures requiring increased electricity for cooling etc., greater risk of flooding events, droughts and deterioration of groundwater. The Nigerian Government has described this threat as “likely to undermine efforts to achieve Nigeria’s development objectives, including the targets set out in Nigeria Vision 20:2020 and the Millennium Development Goals” (FMECCD, 2011). Building designers must be conscious of these threats and mitigate their impact where possible. Furthermore, cities have been identified as being most at risk from these challenges and must respond with proactive measures to create safe, secure and stable environments in which people live. Resilient buildings are core to the functioning of a city for the provision of shelter, work and community spaces.

**Economically viable and affordable**

Energy efficient measures in Nigeria need to be affordable, especially for housing projects. Typically, energy efficient buildings have a higher capital cost than conventional buildings because of the higher quality building materials and systems as well as the bespoke design. On the other hand, operating costs are lower than conventional buildings because of the passive and energy efficient systems. The combination of capital and operating costs is referred to as life cycle costs. Climate-adaptive buildings are commercially attractive because they can achieve lower life cycle costs than conventional buildings.

Countries across the world have been introducing regulations on minimum standards of energy efficiency on new buildings. This is catalysing a new market with expectations of better indoor environments and lower operating energy costs. According to studies, this market is willing to pay a premium for the higher quality buildings. This shift in perception has also been driven by the advent of iconic developments such as Beddington Zero Energy Development (BedZED) in the UK.

Furthermore, not all energy efficient buildings are more expensive than traditional buildings. Some measures such as limiting window sizes and omitting air-conditioning systems may even save money. Particularly for the mass housing market it is necessary to choose which measures are most important and to prioritise these over those which are less costly.

Different levels of energy efficiency and the associated costs are reflected in the variants presented in the case studies at the end of this guideline. Energy efficiency measures can be chosen depending on what is affordable for the target audience.



Figure 14: BedZED community development (courtesy of Wikimedia commons) © Arup



### Encourage renewable energy development

Nigeria has an abundance of renewable resources that, with the continuously falling price of renewable energy technology, are becoming more and more accessible for electricity generation. Currently, the use of diesel and petrol generators is prolific because of the unreliable grid supply. Although petrol/diesel generation currently represents the minimum capital cost solution, the running costs are very high and longer term life cycle costing favours renewable energy generation by PV.

# 04 Bioclimatic Building Design: Concepts

## 4.1 Chapter Summary

Bioclimatic architecture can be defined as design based upon climate considerations and attempting to achieve physical comfort for occupants with minimum use of resources, while taking into account behavioural and psychological aspects.

This chapter summarises in simple terms the building physics concepts required to understand heat flows into and out of buildings, together with the theories of comfort and in particular adaptive comfort which suggests that people adapt their perception of thermal comfort to outdoor weather conditions.

Bioclimatic building design provides comfortable indoor conditions without intensive cooling. Cooling the building to 21°C or even colder harms the occupant’s health and causes energy consumption to skyrocket.

## 4.2 Bioclimatic Design Approach

Bioclimatic architecture can be defined as that based upon climate considerations, attempting to achieve physical comfort for occupants with minimum use of resources (e.g. energy sources, water etc.), while taking into account behavioural and psychological aspects. It’s based on achieving some control of heat gains and losses from the building resulting from the climate and thus optimise environmental conditions within. Bioclimatic design is the starting point and foundation for an energy efficient building.

Bioclimatic design does not impose any particular style on an architect, and there are a wide variety of different buildings which demonstrate effective bio-climatic responsiveness in their respective climates. Typically, a recognisable trait is their optimised orientation and incorporation of solar protection.

Figure 15: Energy efficiency strategy. Source: Arup

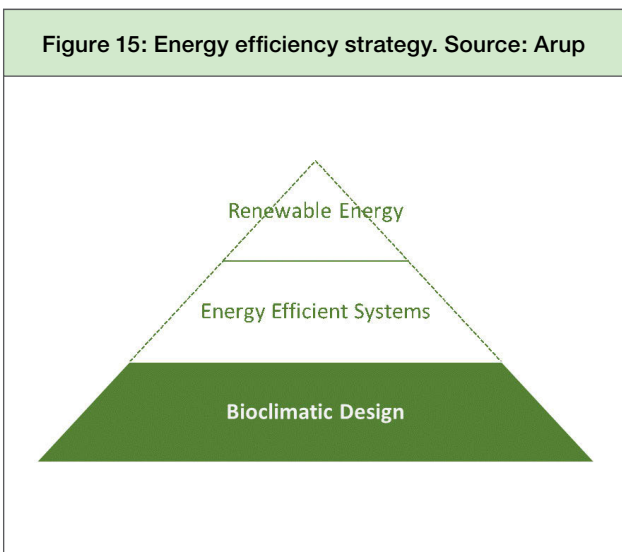

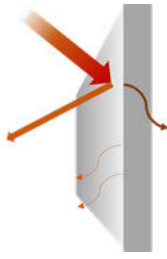
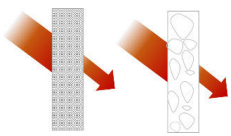
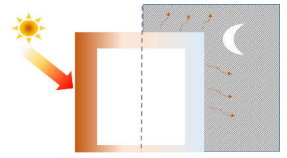

Figure 16: Faculty of Social Sciences, Obafemi Awolowo University. Source: ©Anthony Okoye



AIR	Airflow movement	Warm air is less dense and rises while cold air is denser and moves downward displacing warm air.	
	Evaporation	Evaporation uses energy to change from a liquid to gaseous state and thus removes heat. Dry air absorbs water increasing its humidity and decreasing its temperature.	
MASS	Surface properties: <ul style="list-style-type: none"> <li>• Absorptance</li> <li>• Reflectance</li> <li>• Emittance</li> </ul>	Light colours reflect solar radiation, while dark colours absorb it. The type of material should also be considered as they vary in emittance potential. Both properties are combined into a metric of solar reflectance index (SRI) and in hot climates should be as high as possible.	
	Porosity	Trapped air reduces heat transfer. A material containing air gaps is an insulator and reduces conductive transfer.	
	Thermal inertia	It is the capacity for storing energy. Dense materials can store more thermal energy (heat) releasing it when temperatures drop.	

### 4.3 Physics of Bioclimatic Design

Bioclimatic design uses physics principles to enhance a building's interaction with the environment. The key physical interactions are described below.

Making use of these concepts, designers can select the most appropriate bioclimatic design strategies for the climate in which the building will be constructed.

### 4.4 Climate Concepts

Climate is the factor determining the physical mechanisms used to achieve thermal comfort in a building. Climate is affected by a combination of latitude, terrain and altitude, as well as nearby vegetation, water bodies and wind. The main variables to be considered in bioclimatic design are summarised in the following table:

**Table 1: Climate parameters in bioclimatic building design**

Data	Units
Air temperature (T <sup>a</sup> )	°C
Solar radiation (direct and diffuse)	kWh/m <sup>2</sup>
Sun angle	A (°)
Relative humidity (RH)	%
Wind speed and direction	m/s, (°)
Precipitation	mm

It can be a challenge to get reliable climate data representative of each location. For Nigeria, information is available from the Nigerian Meteorological Agency or from software tools such as Meteonorm<sup>6</sup>.

6. <http://meteonorm.com/>

### 4.5 Microclimate

A microclimate is the distinctive climate of a small area such as a neighbourhood or a park which may be slightly different from the regional climate. The combination of many different microclimate conditions is what builds up to the overall climate of the urban environment. Good master planning and building design can make improvements to the microclimate which in turn improve conditions inside the buildings, as well as improving the outside environment.

The city acts as a huge thermal storage system and heat generated in the built-up areas can lead to a “heat island” phenomenon where temperatures in the city centre rise several degrees higher than the outlying areas. There are numerous causes for this, including the replacement of vegetated areas by hard surfaces and buildings. Higher urban temperatures have a very important impact not only on human comfort, but also on electricity demand for air conditioning (Santamouris, 2001). This is especially critical in hot climates where the warmer temperatures reduce potential for night cooling.

**Figure 17: Climate parameters**

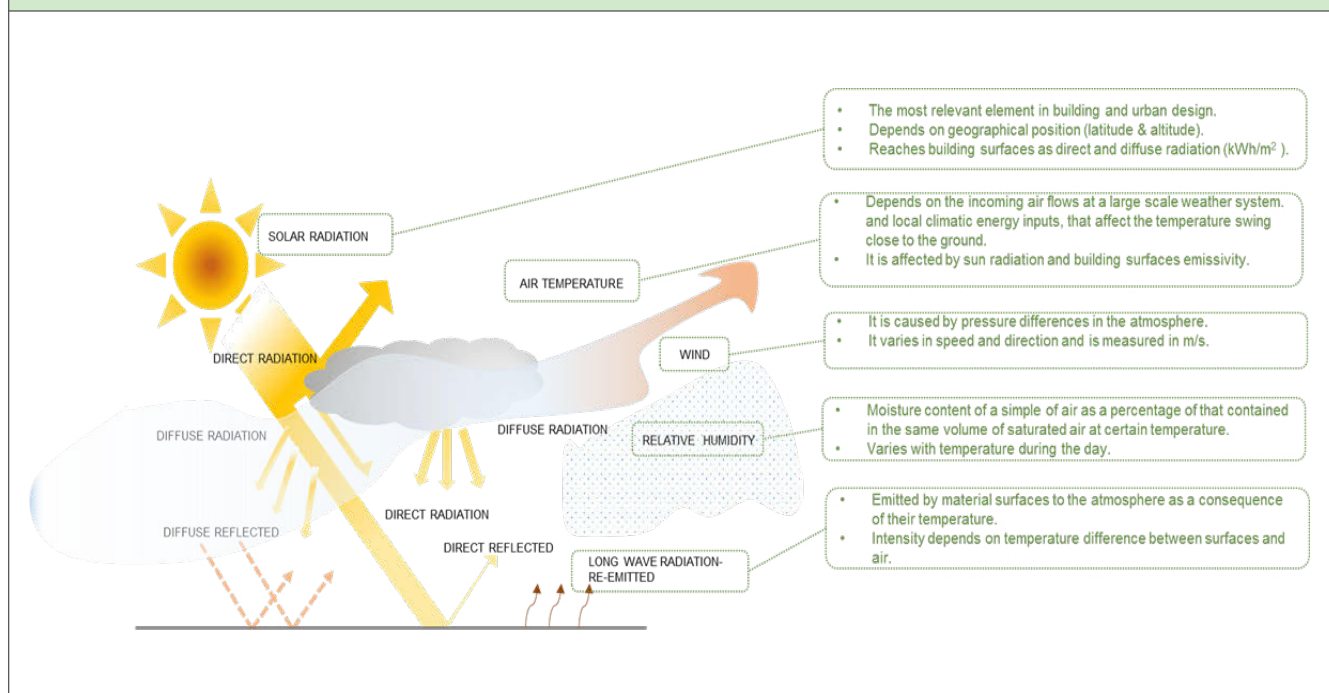

The following figure shows climate aspects affecting microclimate conditions:

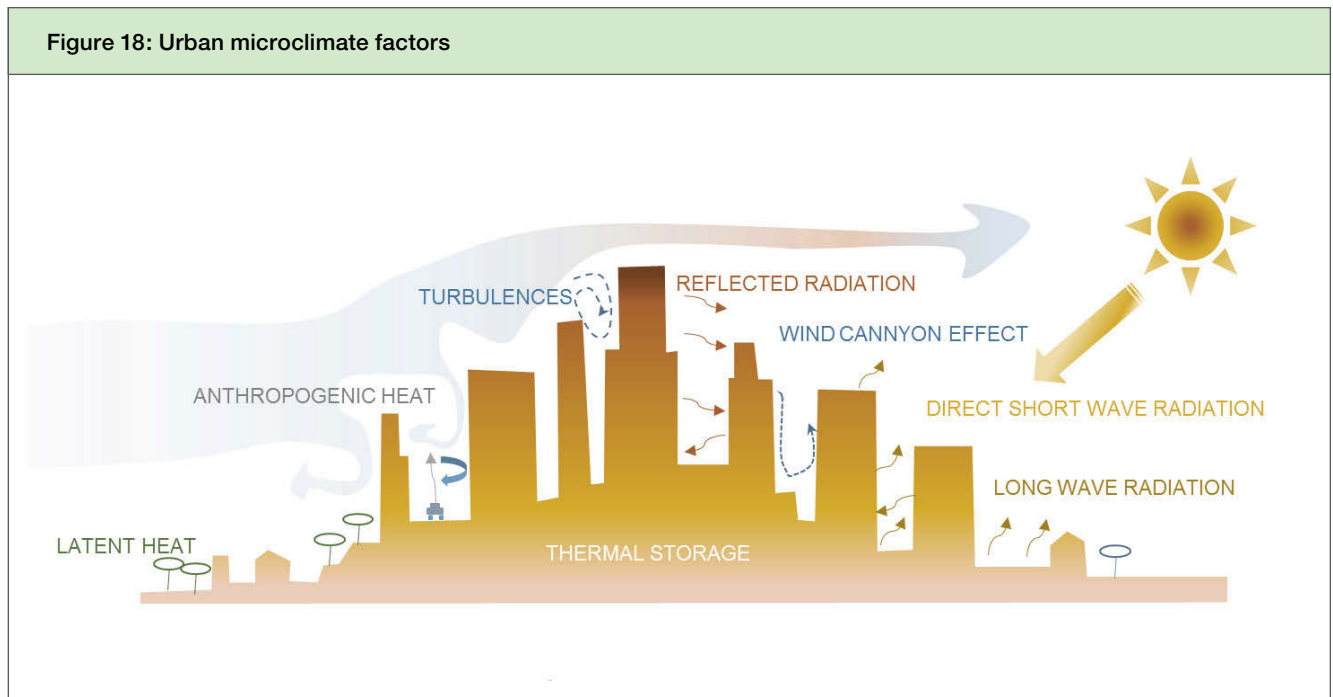

Enhancing the microclimate is geared towards creating a more comfortable environment for those outdoors as well reducing the need for cooling systems inside buildings.

#### 4.5 Thermal Comfort

Thermal comfort is the condition of mind that expresses satisfaction with the thermal environment and is assessed by subjective evaluation. This feeling of satisfaction is achieved when the heat generated by human metabolism is allowed to dissipate, thus maintaining thermal equilibrium with the surroundings (ANSI/ASHRAE Standard 55).

The figure shows the mechanisms that the human body uses to achieve thermal equilibrium.

Within the built environment, thermal comfort is very difficult to define since different people prefer different conditions. ASHRAE Standard 55, defines a thermally comfortable commercial building as a building “that meets the needs of [at least] 80% of occupants.”

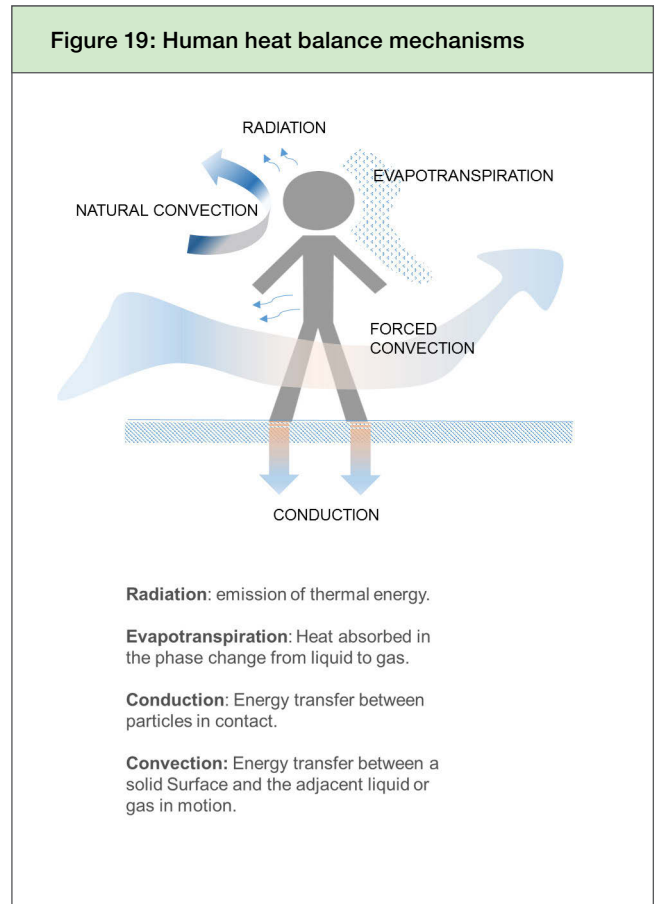

The concept of comfort used in most air conditioned buildings is to try and maintain internal conditions at a fixed “ideal” air temperature by using energy-intensive air conditioning systems with automatic controls. However, with growing concerns around energy efficiency and indoor air quality, this approach has been called into question. More complex formulae to define comfort have been developed which include factors in addition to air temperature such as surface temperatures, humidity, air velocity, clothing and activity levels. Bioclimatic design embeds these mechanisms and uses the outdoor climate conditions to promote human heat balance through the right application of design elements: Solar radiation, wind and humidity are included in the design as dynamic inputs that help to define building geometry, construction systems and operational parameters.

The psychological state of the occupants and how much control they have over their surroundings also plays an important role in determining how comfortable they feel in an environment. For example, if they are able to adjust temperatures, open windows, or are free to move to other parts of the building, they are more likely to tolerate some variations in conditions. The local way of dressing is usually better suited to local climatic conditions than the international business dress code. A building where occupants are allowed to open windows and doors not only allows for natural ventilation, but also gives occupants a sense of connection to the outdoors. This has shown to also increase productivity in offices.

The psychological state of the occupants and how much

Figure 20: Human Comfort Parameters



## Adaptive comfort

The concept of adaptive comfort addresses the need for a more flexible definition of the numerical parameters affecting thermal comfort and includes human psychology alongside physical characteristics of the indoor environment.

Adaptive thermal comfort is a theory that suggests a human connection to the outdoors and control over the immediate environment, allowing them to adapt to (and even prefer) a wider range of thermal conditions than is generally considered comfortable (J.F.Nicol, 2002, G.S. Brager, 2001). It is based on empirical research that showed that outdoor climate influences indoor comfort because humans can naturally adapt to different temperatures during different times of the year.

The most recent version of ASHRAE Standard 55 recognises the role of adaptive factors in establishing thermal comfort, and includes an Adaptive Comfort Standard (ACS) that allows a wider range of indoor temperatures for naturally ventilated buildings which are necessarily more susceptible to outdoor conditions (J.F.Nicol, 2002).

The adaptive chart included in the ACS defines zones of 80% and 90% satisfaction depending on the monthly mean outdoor temperature. This suggests that in Nigeria with a monthly mean external temperature of around 26°C, 90% of occupants would be comfortable with temperatures up to 28°C.

Figure 21: Adaptive Comfort Chart.

Source: ASHRAE 55 2010

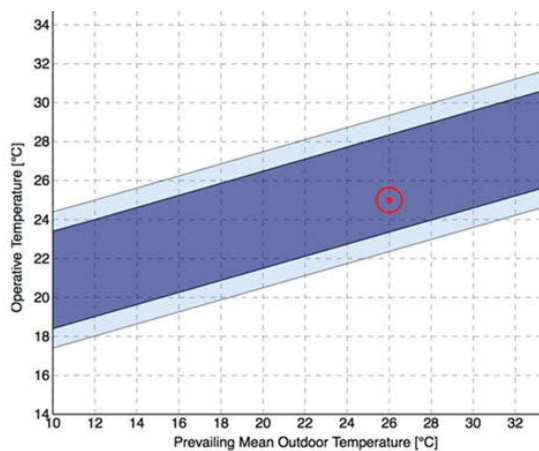

# 05 Bioclimatic Architecture in Nigeria

## 5.1 Chapter Summary

This chapter aims to give practitioners advice on how to apply the principles of bioclimatic design to buildings in Nigeria. It starts with a description of the Nigerian climate and comments on relevant vernacular architecture and what can be learnt from Nigerian architecture past and present. Compact buildings with small windows and high thermal mass are preferred in the hot & dry climate, while in the hot & humid climate, more open, permeable buildings are found.

The two main objectives which inform the design are:

- to minimise heat gains into the building
- to promote heat loss where possible

On larger sites it is possible to create a microclimate around a building through the use of landscaping and vegetation. Orientation of buildings so that the majority of windows face approximately North and South is crucial in reducing solar gains.

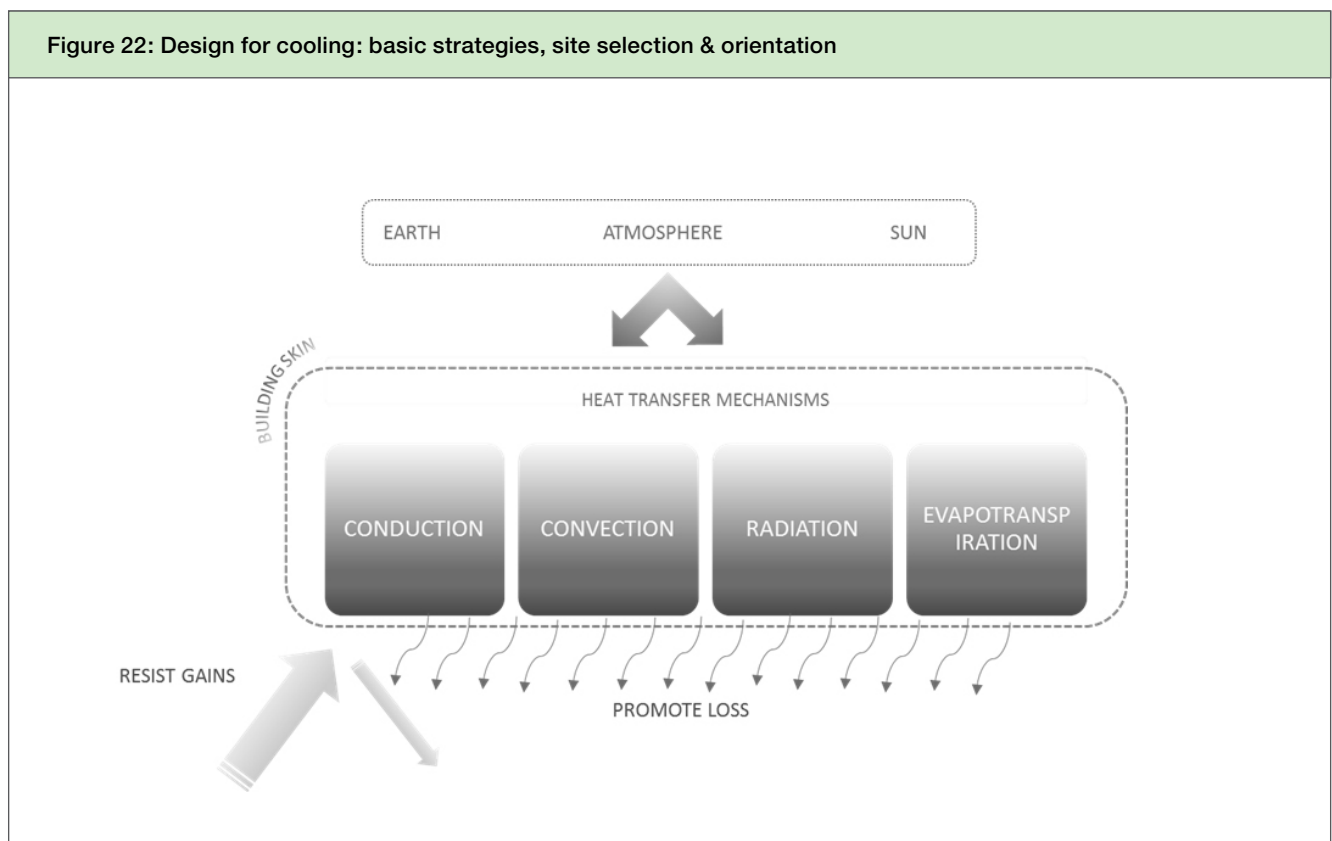



### Building form & geometry

The building form dictates the effectiveness of natural daylight and natural ventilation through a building. Features such as courtyards and buffer zones are described.

### Building envelope

Window and shading design is developed in some detail, together with suggestions on how to improve the insulation of roofs and walls.

### Strategies for passive cooling

Thermal mass is an effective way of stabilising temperatures in climates which have cooler nights, such as the hot & dry climate in northern Nigeria. Other strategies such as evaporative cooling and ventilated facades are briefly discussed.

### Summary of measures for each climate

While most of the strategies for reducing heat gains are valid for all areas of Nigeria, some strategies are only applicable to one climate. The table below summarizes which strategies are most suited to each climatic zone.

## 5.2 Nigerian Climate Characteristics

Nigeria is located wholly within the tropical zone but shows significant climatic variations in different regions of the country. Two principal wind currents affect Nigeria, the Harmattan, from the northeast, which is hot and dry and carries a reddish dust from the desert. The southwest wind brings cloudy and rainy weather. These conditions result in four climate types distinguishable as one moves from South to North.

The climate is predominantly hot & dry in the North, with higher temperature and humidity swings, and hot & humid in the South, with fairly constant temperature and humidity levels. The following diagrams show the maximum and minimum temperatures in Nigeria, the mean temperature and mean relative humidity levels, and how these result in a number of different climatic zones. The city of Jos is located at a high altitude and as a result has its own unique climate, which is significantly cooler than the surrounding areas.

Strategy	Hot & dry	Hot & humid
Compact geometry	✓	✗
Exterior Shading	✓	✓
Daylighting	✓	✓
Window low SHGC	✓	✓
Cross/stack ventilation (if naturally ventilated)	✓	✓
Building permeability (if naturally ventilated)	✗	✓
Roof Insulation	✓	✓
Wall insulation (exterior)	✓	✗
High thermal mass	✓	✗
Low thermal mass	✗	✓
Evaporative cooling	✓	✗

Figure 23: Climate Zones in Nigeria.

Source: (O.M. Eludoyin, 2013)

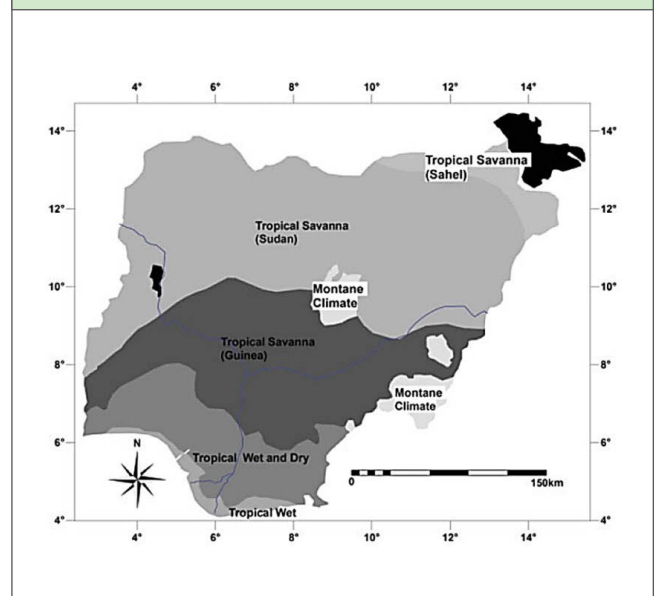

**Figure 24: Minimum and maximum temperatures in Nigeria. Source: (O.M. Eludoyin, 2013)**

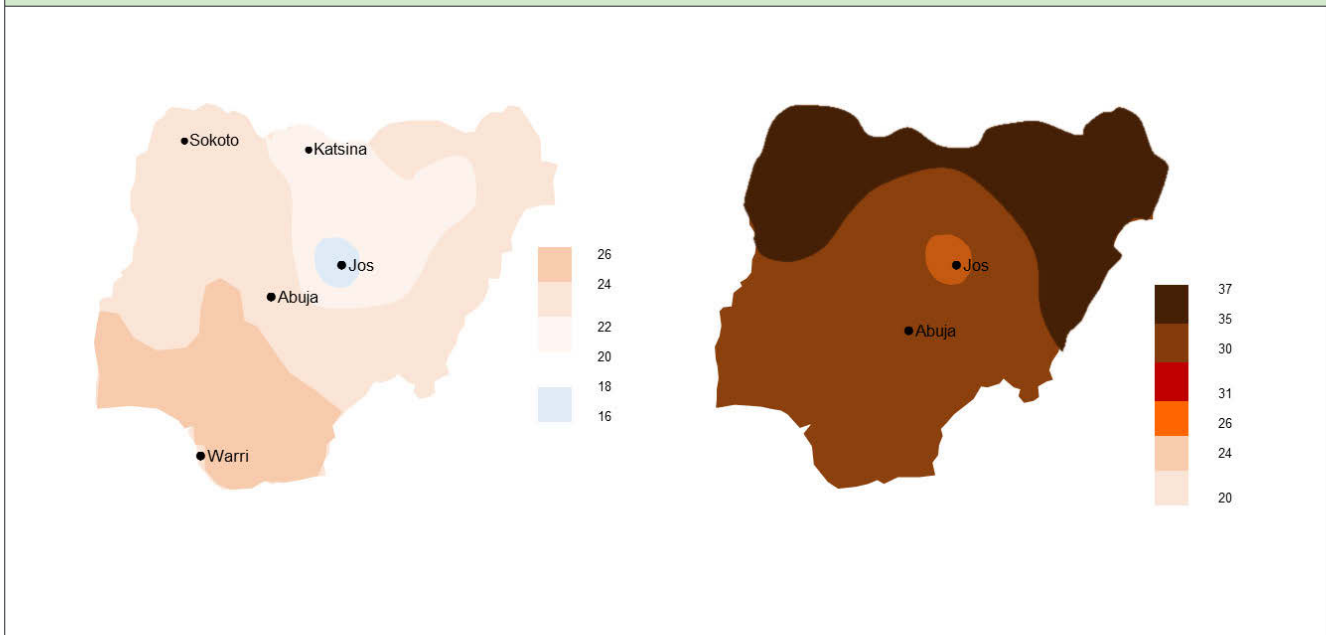

**Coastal area: tropical wet-monsoon**

Near the southern coast, the seasons are not sharply defined, with constant temperatures throughout the year. Temperatures rarely exceed 32°C, but humidity is very high and nights are hot. This area of the country falls within the Koppen Classification “Am” (Hufty, 2001). This climate is influenced by the monsoons originating from the South Atlantic Ocean, which are carried into the country by the seasonal maritime winds. Over 4,000mm of rainfall is received in the coastal region of Nigeria around the Niger delta. Figure 25 shows the climate data for Warri, located in this climate zone.

**Southern area: tropical wet and dry**

The southern region of Nigeria experiences two rainy periods with dry seasons in between. Temperatures remain almost constant for the whole year, again with very high humidity levels throughout the year. This area of the country falls within the Koppen Classification “Af” (Hufty, 2001). Figure 26 shows the climate data for Lagos, located within the tropical humid-dry zone.

**Western Nigeria to central Nigeria area: tropical savannah**

The tropical savannah climate, exerts enormous influence on the country. This climate has a very distinguishable rainy season and a dry season. Unlike the coastal zone, there is a significant difference between daytime and night time temperatures (diurnal variation). The Harmattan wind occurs during the hot season and brings dust from the Sahara Desert. This climate zone falls within the Koppen classification “Aw” (Hufty, 2001). Figure 27 shows climate data for Sokoto, located within the tropical savannah zone.

**Northern area: tropical dry-Sahel**

In this zone, total annual rainfall is lower than in the southern and central part of Nigeria. The rainy season typically lasts for only three to four months (June–September). The rest of the year is hot and dry with variable relative humidity according to the rainy periods. Temperatures can climb as high as 40°C. This climate zone falls within the Koppel classification “Bash” (Hufty, 2001). As with the previous zone, there is significant daily temperature variation between day and night. Figure 28 shows the climate data for Nguru, located in this climate zone.

**Figure 25: Coastal area. Climate data for Warri. Source: Climate-Data.org<sup>7</sup>**

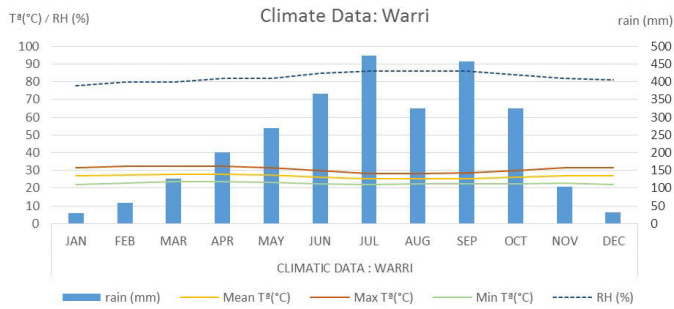

**Figure 26: Southern area. Climate data for Lagos. Source: Climate-Data.org**

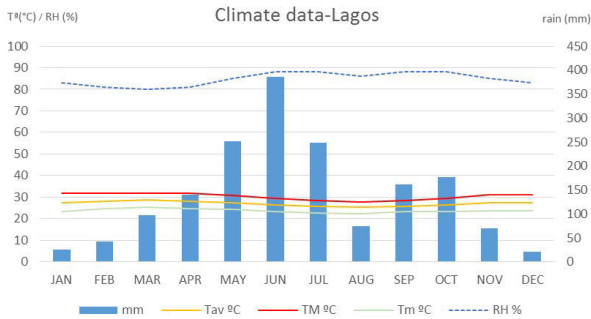

**Figure 27: Western to central. Climate data for Sokoto. Source: Climate-Data.org**

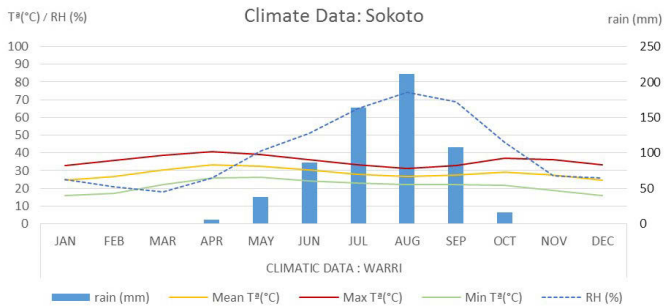

**Figure 28: Northern area. Climate data for Nguru: Source Climate-Data.org**

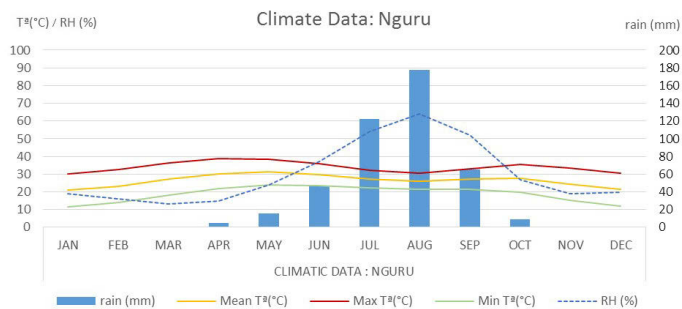

7. <http://climate-data.org>

### Thermal comfort index: Effective Temperature

Humidity should be factored in when assessing thermal comfort as it has been recognised that higher humidity levels reduce the body’s capacity to regulate temperature via evaporation. As such, a metric was developed to combine both air temperature and humidity known as effective temperature index. This index is useful to quantify thermal conditions in the Tropics.

The following maps integrated effect of mean average temperature and humidity represented as Effective Temperature. The Tropical Savannah zone shows lower effective temperatures than the Southern part of the city due to the effect of the high humidity, hence making this climate more challenging for achieving comfort relying only on climate-adapted building design strategies.

### 5.3 Vernacular Architecture: Learning from History

Nigeria like most of Africa, has a history of sustainable, climate-adaptive architecture. Its indigenous buildings share many of the same objectives with actual “green buildings” since they follow the basic prerequisites of sustainable utilisation of environmental resources.

The trends in Nigerian architecture comprise three main eras: the indigenous/traditional, tropical architecture, and the contemporary.

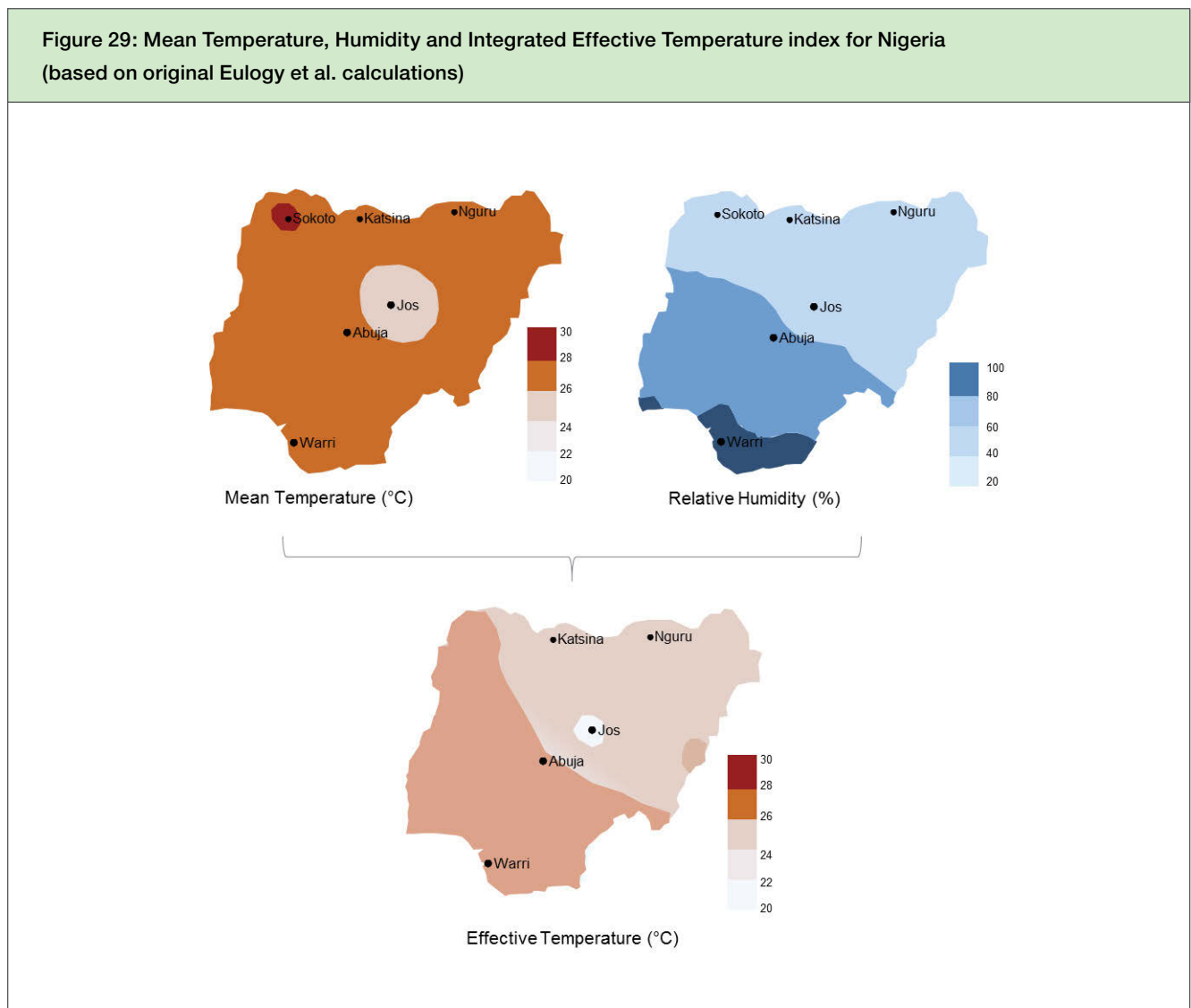

Figure 30: Typical roof construction with palms.

Source: © Creative Commons<sup>8</sup>



Figure 31: Sample of sun dried clay bricks.

Source: Picture by McKay Savage

©Creative Commons<sup>9</sup>



Figure 32: Kano City Mud Wall. Source: image by

David Holt ©Creative Commons<sup>10</sup>



## Indigenous/Traditional

The different ethnic groups, religions, cultures and climate zones that make up the country are reflected in an exceptionally diverse traditional architecture. However, there is common ground due to the use of locally sourced materials for the buildings, and an emphasis on the supremacy of spirituality, community and family life by incorporating family gathering and worship spaces. Settlements typically had community spaces at the centre, a feature which commonly differs in the way modern cities are planned and constructed in Nigeria.

Locally sourced timber, mud bricks and palm leaves were the basic construction materials – these low-cost, simple technologies allowed a minimum environmental footprint and were well adapted to the tropical climate. The lifespan of such buildings was not long, but they could easily be repaired and rebuilt as needed, with a life span concept very different to today's approach to architecture.

### North Nigeria – hot & dry

In North Nigeria, the most common construction material was mud or adobe, used in the form of sun dried block construction, wattle and daub or as a special brick called tubal reinforced with palm branches.

In urban settlements, vernacular architecture was rooted in the old city states existing since the fifteenth century. The architecture is mainly in adobe, reinforced with palm stems. Master craftsmen evolved a structural system using adobe to its structural limits exhibiting abstract art decoration in their walls.

8, 9, 10. <https://creativecommons.org/licenses/by-sa/2.0/legalcode>

Table 3 below summarises the main characteristics of hot & dry vernacular architecture in Nigeria:

Table 3: Hot & dry. Vernacular architecture characteristics	
<b>Building form</b>	<b>Volume:</b> compact to minimise heat gains
<b>Building envelope</b>	<b>Openings:</b> narrow and long to minimise solar gains and maximise daylight, small to avoid dust during Harmattan
	<b>High thermal mass:</b> to balance indoor temperatures during day
	<b>Roof:</b> domed roof, with light colours, to control heat gains, shaped to capture and channel rain water

Table 4: Hot & humid. Vernacular architecture characteristics	
<b>Building form</b>	<b>Volume:</b> expanded to maximise airflow
<b>Building envelope</b>	<b>Openings:</b> wide and shaded to minimise solar gains while maximising ventilation
	<b>Low thermal mass:</b> to avoid heat storage in the envelope
	<b>Roof:</b> pitched roof, covered by palm leaves to allow air infiltration while also able to shed very high intensity rainfall

### Southern Nigeria – hot & humid

The traditional architecture in this climate with very hot and humid conditions and little variation between day and night time temperatures is characterised by open constructions, with very low thermal capacity and large windows. Buildings are often arranged around a courtyard in order to allow cross ventilation of all rooms. Stepped thatched roofs are favoured to quickly shed rain, and feature large overhangs providing shelter and shading to the walls and openings.

Common materials used in southern Nigerian houses include mud, timber and raffia/palm stems. The table 4 above summarises the main characteristics of hot & humid vernacular architecture in Nigeria.

### Tropical architecture: Iconic buildings and architects

From the early 1930s to the end of the 1960s, climate-responsive design matured as a global phenomenon, developing as “Tropical Architecture” in Asia and Africa along the colonies of the British Empire. In the UK, Tropical

Architects such as Otto Koenigsberger, Jane Drew, Maxwell Fry, Leo De Syllas, Fello Atkinson, and George Atkinson led on the development of energy-conscious climatic orientated design (Olgay, 1963, Atkinson, 1953).

Tropical architecture was a form of modernist architecture, initiated by this group of architects who worked in West Africa around the end of the Second World War. Uduku, categorises tropical architecture as early-tropical (pre-1955), mid-tropical (1955 to early 1960), and late tropical (late 1960s to early 1970s) (Uduku, 2006). Examples include the Ghana schools project, the African premier University of Ibadan, the student hostels in the University of Lagos, the University of Ibadan complex, University of Ife Library, humanities, social science, African Studies, Secretariat and Agricultural Science buildings, Elder Dempster’s office building, and Olaoluwakitan House in Lagos.

Notable practitioners included Godwin and Hopwood, James Cubitt, Design Group, Femi Majekudumi, Interstate, Alex Ekwueme to name a few. Unfortunately, some of the projects by these firms in the last decade indicate a deviation from Tropical architectural principles.

**Figure 33: Bioclimatic strategies in typical urban buildings: Shading and natural ventilation.**

Image Source: ©Anthony Okoye



### Contemporary architecture

With the advent of affordable air conditioning systems, many architects felt released from the “restrictions” of passive design, and designed buildings purely based on aesthetic appearances, often copying styles developed for very different climatic zones. Sadly, such buildings tend to be both energy inefficient and uncomfortable for their occupants. While the Tropical Architecture style buildings are now old and may appear dated, the principles behind them could still be applied to modern architecture with fresh interpretations given the modern materials that are now available.

### Bioclimatic design strategies for Nigeria

In hot climates like that of Nigeria, the main aim is to maintain the indoor ambient temperature at a comfortable level. As such, design strategies should be driven by achieving the following objectives:

#### Objective 1- Minimising heat gains

This is the most important objective, common to both the hot & dry and the hot & humid climates, which is to minimise the amount of heat gains inside the building. This objective informs the building orientation, the thermal insulation of the structure, the window design and many other aspects.

#### Objective 2- Promoting heat loss

When the outside temperature is low (for example at night particularly in the hot & dry climate), the building should be designed so that heat stored in the building can be released. This forms the basis of most passive cooling techniques such as thermal mass which are explained later in this chapter. Other ways of encouraging heat loss is by promoting air movement through the building, in the hot & dry climate and evaporative cooling can also be effective.

The design of a building typically follows the following process.

**Figure 34: Sequence of bioclimatic strategies**

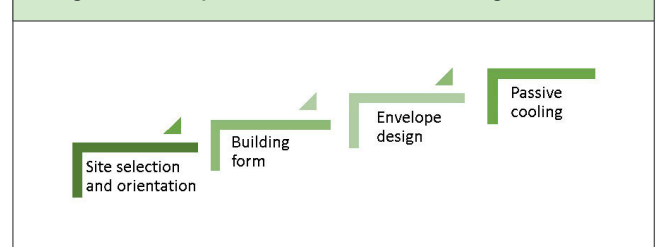

**Site selection and orientation:** The building orientation towards the sun and the wind are the main factors determining the energy balance of buildings since this will affect air movement and solar gains within the building.

**Building form and geometry:** Definition of volume, geometrical components and openings to stop the undesirable thermal gains and promote thermal loss.

**Building envelope:** Selection of materials and building skin components aimed at reducing heat gains by conduction, convection and radiation, control humidity and promote thermal loss. Materials physical properties (colour, thermal mass, conductivity) are critical for good thermal performance.

**Passive cooling strategies:** Architectural strategies for cooling the building without mechanical systems.

**Site selection and orientation**

Depending on the size of the site, consideration should be given to improving the microclimate around the building using landscaping features. Trees can be an effective way of providing shading to buildings and evaporative cooling. Attempts should be made to preserve any existing mature trees or other ecological systems on the site.

Direct solar irradiance contributes to solar heat gains. Windows should, therefore, be minimised in direction of sunlight. As such building orientation in relation to the sun path is important. Nigeria is near the Equator and as such there is not very much variation in the sun path over the year which makes

Figure 35: Sun path for Kano, Nigeria. Source: Arup, Ecotect analysis

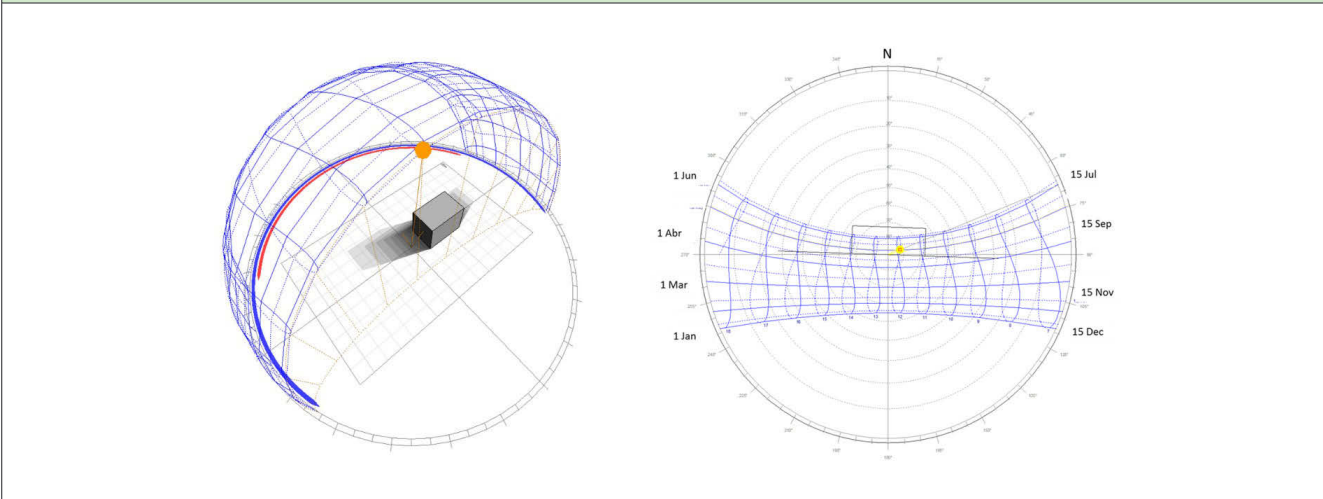
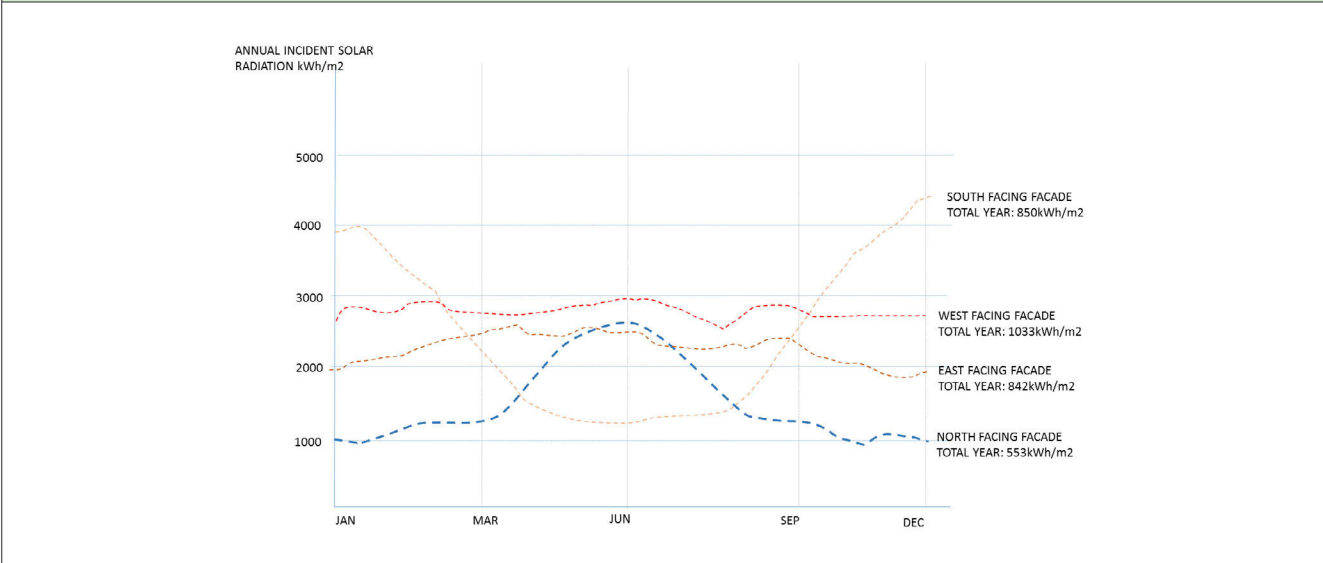

Figure 36: Annual incident radiation for Kano, Nigeria. Source: Arup, Ecotect analysis





optimising orientation and shading relatively straightforward. The high solar altitude means that the roof is the area with the highest solar radiation, and roof lights should be avoided.

The north facing façade has the lowest incident solar radiation, although it does receive direct sunlight for a few months in the year. The south facade receives radiation throughout the year, but the high sun angle means that it is relatively easy to prevent this radiation reaching the building façades by using overhangs or horizontal shading. The east façade receives similar cumulative radiation during the year to the south façade, but due to the low sun angle in the morning it is very difficult to prevent this entering the building. Finally, the west façade has the highest gains, and with low sun angles in the afternoon, windows facing this direction should be minimised. The optimum orientation would be that with windows facing north and south, reducing openings to east and west.

### Building form and geometry

Strategies related to the building form deal mainly with their major components, volume, configuration of rooms and outdoor areas.

### Compact geometry

Reducing building outer skin area in relation to the volume proportionally reduces heat gains. Compact forms such as cubes show lower heat gains than elongated or articulated forms for the same volume, cooling demand will be lower for the lower surface-volume ratio (S/V).

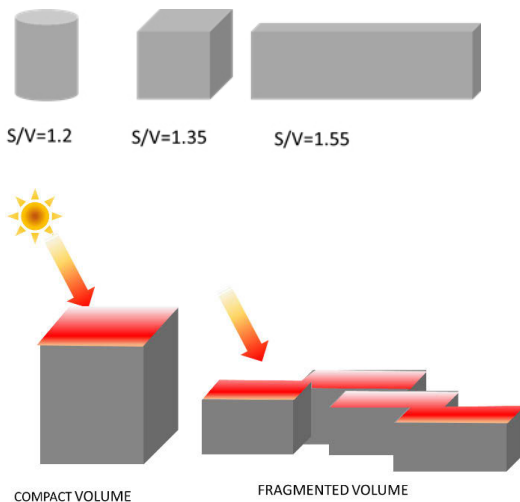

### Thermal zoning

Buffer zones can be used to help protect internal spaces from outside weather conditions. These are spaces which will not be regularly occupied and therefore temperatures outside thermal comfort levels are acceptable. A typical approach in Nigeria is shaded balconies and circulation spaces around buildings.

In office buildings buffer spaces can be especially useful on E-W facing facades.

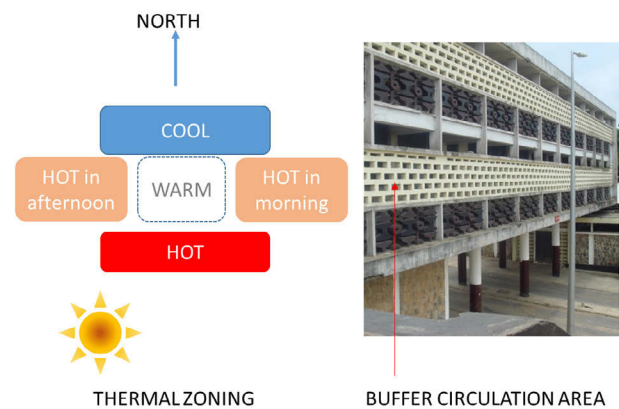

### Daylighting zones and courtyards

Rooms can be arranged within the building so that activities that need higher lighting levels can be located close to the windows avoiding exposure in areas where daylight is not critical.

Courtyards also offer the possibility of providing daylight to areas located in the interior.

Screened and shaded outdoor living areas can be very pleasant spaces in hot weather.

For regions with high solar altitude, central courtyards with shading offer a comfortable outdoor area which provides daylight to the surrounding areas.

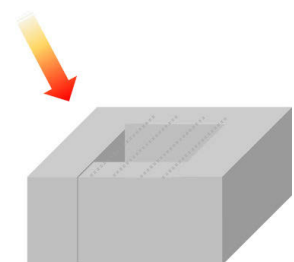

Figure 37: Courtyard strategy. Source: Arup ©Jacob Knight



### Natural ventilation

Various rules of thumb exist to help with the design of naturally ventilated spaces.

Single sided openings are the simplest form of ventilation, but are only viable for room depths around 6m or 2.5 times the ceiling height.

Cross ventilation is more effective since the wind pressure will help force air through the building. In this case, room depths of around 12m or more are possible (5 times the ceiling height).<sup>11</sup>

More complex natural ventilation schemes are possible involving atria, light wells etc. Atria must be designed with caution in Nigeria, since any roof lights will result in high solar gains into the building.

Figure 38: Natural ventilation schemes

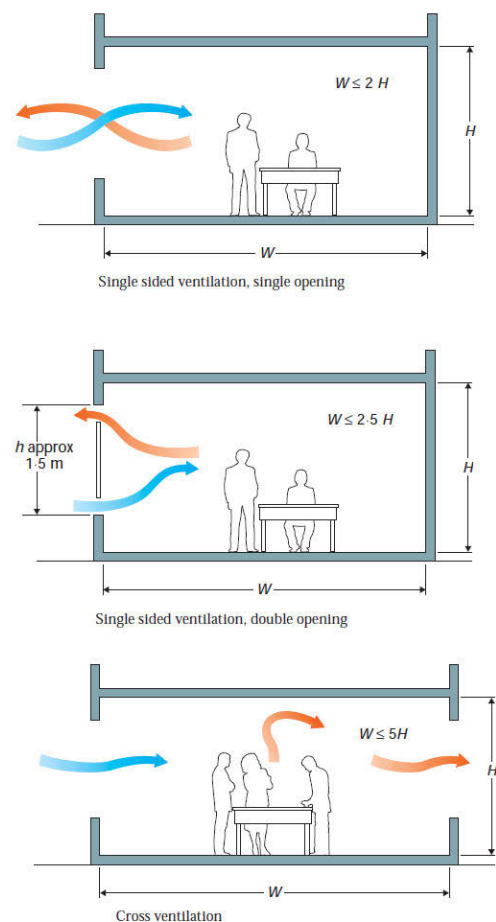

11. CIBSE, AM10 - Natural ventilation in non-domestic buildings, 2005

## Building envelope

### Shading elements

Exterior shading reduces the direct solar radiation entering the building through the windows.

North and south facing elements can be easily shaded with overhangs and horizontal shading, given the high solar altitude in Nigeria.

East and west façades are problematic and require a combination of horizontal and vertical shading, since the sun is very low and reaches the façades almost perpendicularly.

The table below gives the lowest sun angle for Kano and Lagos Latitudes to allow approximate overhang sizing.



**Table 5: Lowest sun angle from horizontal to avoid all direct sunlight between 9am and 3pm**

Façade orientation	Due North	10° E/W of North	20° E/W of North	Due South	10° E/W of South	20° E/W of South
<b>Lagos (6°N)</b>	72°	66°	60°	60°	56°	51°
<b>Kano (12°N)</b>	75°	69°	63°	54°	51°	47°

Figure 39: Exterior shading strategy. Image source: ©Anthony Okoye



## Window design

Daylight is necessary for human comfort and reduces the need for artificial lighting. Daylight incidence must be balanced against the need to minimise solar heat gains and avoid glare from direct sunlight.

The amount of solar heat gain which a window will transmit can vary depending on the coating. Modern coatings allow the heat gains (infra-red) to be reduced while still allowing much of the daylight to pass through the window enabling a good level of daylight to enter whilst avoiding much of the heat gain. The Solar Heat Gain Coefficient (SHGC) is the fraction of incident solar radiation that actually enters a building through the entire window assembly as heat gain. The g-value is the equivalent for the glass itself (ignoring the frame).

The visual transmittance (VT) is how much daylight passes through the window. A VT of at least 60% is recommended to receive sufficient daylight. Tinted glazing with a strong colour can give an unpleasant internal environment.

The table below shows several glazing configurations. The optimal combination should be selected on a case by case basis based on factors such as the size of windows, the level of exposure of the window and the daylight requirements.

It is important to remember that while tinted glass will help reduce solar gains, it will not prevent problems with glare. The most effective way of avoiding glare is to ensure that no direct sunlight enters the building, using careful orientation and external shading as described previously.

Internal shading (e.g. Venetian blinds) can be used to reduce glare, but these do not perform well in heat gain terms because they do not prevent the solar gains from entering the building.

The comparison between the shading coefficients for different internal and external shading devices shows that while internal blind solutions can achieve a shading factor of around 0.6-0.7, the external shading solutions are significantly more effective.

**Table 6: Visual and solar performance of a selection of typical glazing options**  
(U values exclude window frame). Source: Pilkington technical data

Glazing type	Visual light transmittance (high is good)	g value (solar factor) (low is good)	U value (W/m <sup>2</sup> K) (low is good)
Single glazing (clear)	88%	0.82	5.8
Single glazing with hard coating – mild tint (Pilkington Safety shield Solar E Clear)	60%	0.53	5.8
Single glazing with hard coating – heavy tint (Pilkington Safety shield Solar E + Grey)	25%	0.34	5.8
Single glazing with reflective coating (Pilkington Solar shield Silver S10)	11%	0.23	5.8
Double glazing (clear, no coatings)	79%	0.7	2.7
Double glazing, solar control with soft coating (e.g. Pilkington Suncool 66/33)	65%	0.36	1.5

### Materials surface properties: Solar Reflectance Index

Dark surfaces absorb solar radiation and become hot which raises the air temperature surrounding them and slowly dissipates heat into a building. Using light colours and reflective materials can, according to some estimates, reduce the heat gain of a building by up to 30% during the hottest hours of the day (Akbari, 1992).

The Solar Reflectance Index (SRI) of a material describes the ability of that material to reflect solar radiation and emit

heat. The SRI for a black surface is close to 0 while for a white surface is close to 100. For roof surfaces, a SRI higher than 78 is recommended by most green building certification schemes such as LEED® in order to minimise heat gains through the roof and reduce the contribution to the heat island effect in urban areas.

The following table shows examples of SRI for typical roofing materials:

Table 7: Solar Reflectance Index (SRI) of common roofing materials. Source: G.Z. Brown, 2001

Roofing material	Solar Reflectance	Infrared Emittance	Temperature rise	SRI
Galvanized steel	0.61	0.04	31°C	46
Tiles-clay red	0.33	0.9	34°C	41
Metal with high reflective white paint	0.67	0.85	16°C	82
Metal with white polymer coating	0.85	0.91	5°C	88

### Thermal resistance (insulation)

The heat transfer potential of materials is described by its U value ( $W/m^2K$ ). A low U value therefore indicates a material is a good insulator. Its inverse, thermal resistance (R), indicates the converse i.e. a large resistance shows a material is a good insulator.

In hot climates, insulating the roof is generally the first priority since the roof is exposed to very high solar gains. Insulating walls, and using double glazed windows will also help to reduce heat transfer into a building, although it is less important in Nigeria than in cold European climates.

Compressed stabilised earth bricks<sup>12</sup> (UN Habitat, 2004) provide a cheap building material with low embodied energy,

due largely to the reduction in the amount of cement used in making and building with them, and the fact that unlike burnt clay bricks no energy is required to fire them. However, because they are solid, they do not provide as much insulation as hollow sandcrete blocks, and therefore either insulation should be applied externally or else the walls should be designed with generous roof overhangs or other shading to minimise the amount of direct sunlight on the walls. Roof overhangs have the added benefit of protecting the earth blocks from rainfall.

Table 8 below shows a variety of roof and wall materials with or without insulation and their associated U and R values.

<sup>12</sup> Pro-poor Growth and Promotion of Employment in Nigeria Program (SEDIN) promotes compressed stabilised earth bricks in Nigeria.

Table 8: R and U values provided by DesignBuilder software

Construction	Typical R value (m <sup>2</sup> K/W)	Typical U value (W/m <sup>2</sup> K)
Metal roof, void, ceiling	0.51	1.95
Metal roof, void, 100mm mineral wool, ceiling	3.22	0.31
Concrete roof with no insulation	0.77	1.30
Concrete roof with 50mm polystyrene on top	2.69	0.37
150mm hollow sandcrete block wall (rendered)	0.53	1.9
230mm hollow sandcrete block wall (rendered)	0.65	1.6
150mm hollow sandcrete, 25mm polystyrene, 25mm cavity, 100mm brick wall	1.28	0.8
150mm stabilised soil block with internal render (class A)	0.33	3.06 <sup>13</sup>

Recent Building Regulations in South Africa require roofs in the sub-tropical coastal zone to achieve a U value of 0.37W/m<sup>2</sup>K.

### Airtightness

Many buildings in Nigeria have gaps in the building envelope which air can leak through. These may be cracks around windows and doors, or larger gaps where the roof meets the walls etc. While in a naturally ventilated buildings this may not be a major concern, improving the sealing will greatly reduce the energy used by air-conditioning systems, and should also improve the occupant comfort levels. Sealing usually takes the form of flexible or brush seals on doors and windows, together with better detailing and construction quality to avoid gaps. For offices and similar buildings, lobbied entrances reduce the amount of fresh air entering the building. On the other hand, to maintain good air quality it is important to provide minimum levels of fresh air to occupants. In air conditioned buildings, it is often best to do this via mechanical systems controlling air exchange.

### Strategies for passive cooling: promote heat loss

Once thermal gains have been reduced by adequate orientation, building form and envelope design, other strategies can be considered to promote heat loss and make the internal space more comfortable.

### Night cooling thermal mass

Thermal mass can be useful in hot climates by absorbing heat that has accumulated inside the building, storing it and releasing it during the cooler night. This strategy requires large areas of high mass (e.g. concrete or tiled floors/soffits, heavyweight brick/stone walls etc.) to be exposed on the inside of a room. During the day, ventilation is restricted and excess heat gains are absorbed by the thermal mass, limiting the internal temperature rise. At night, when the outside temperature is lower, outdoor air is allowed to ventilate through the building to remove the heat.

<sup>13</sup>. Values taken from [http://www.earth-auroville.com/compressed\\_stabilised\\_earth\\_block\\_en.php](http://www.earth-auroville.com/compressed_stabilised_earth_block_en.php).

Figure 40: High thermal mass concept and interlocking stabilised soil blocks.

Image source: left © Jonathan Assink / right image: © The Global Orphan Project

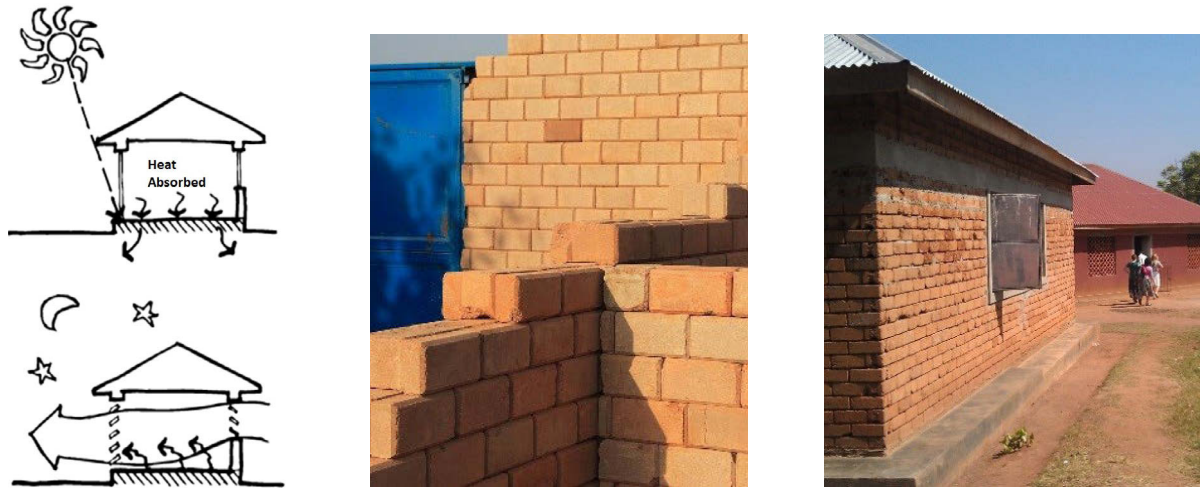

As a rule of thumb, temperature swings of less than 6°C are insufficient to allow night cooling; being optimal where they exceed 10°C. Thermal mass will therefore be most effective in the inland hot & dry areas of Nigeria. It is important that the thermal mass be protected from the outside conditions, ideally using an insulation layer on the outer side. Adding insulation on the inside of the building will decouple the thermal mass and nullify its effectiveness. Similarly adding carpets, false ceilings or other layers of construction will greatly reduce the benefits.



#### Thermal mass storage: rock store cooling

Exposed thermal mass provides a simple and effective way of stabilising internal temperatures and reducing peak cooling loads. A more controllable variation on this is to use rock stores. Air is blown through the rocks at night to cool them down. Then when cooling is required the next day, fresh air is blown through the rocks to cool the air. By using several rock stores, cooling can be kept in reserve for later on in the day. Such systems are used in Harare International School and the Consistory Court in Johannesburg.

Figure 41: Green wall system (Frankfurt). Source: Arup, © Christian Richters



### Ventilated cavity wall

Double skin systems allow heat which has already passed the outer skin surface to be removed prior to passing through the whole wall system. The outer secondary skin provides shade for the inner opaque area, while ventilation of the resulting cavity removes the excess heat that passes through the outer skin.

The efficiency of the double skin system depends on the absorptivity of the outer skin, the emissivity of the cavity and its ventilation rate. The figure below shows a typical ventilated façade. This principle can also be used for glazed walls to achieve greater transparency.

A different version of this system is the vegetated roof or façade where the additional evapotranspiration potential of the vegetation increases the temperature reduction around the inner surface. The requirements for irrigation of these systems need to be considered especially in areas where water is scarce.

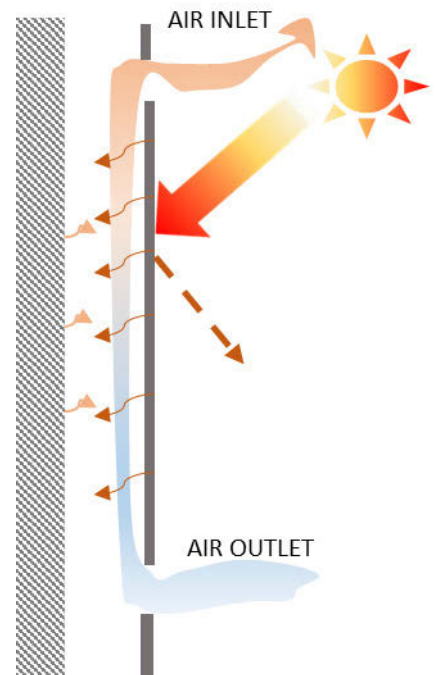



Figure 42: Evaporative cooling tower. Source: Picture by Tim Vo ©Creative Commons<sup>14</sup>



### Evaporative cooling towers

During hot & dry weather, providing water vapour into a space results in its cooling since the water vapour absorbs heat as it evaporates. The water can be provided by mechanical means (see next chapter) or through fountains and water features, or using evaporative towers, where air flows through a wetted pad, is cooled and then falls through gravity into the room.



14. <https://creativecommons.org/licenses/by-sa/2.0/legalcode>

## 5.4 Summary of Key Strategies for Hot & Dry and Hot & Humid Climates

Key passive strategies	Hot & dry	Hot & humid
<b>Climatic conditions</b>	<ul style="list-style-type: none"> <li>• High ambient temperature and solar radiation levels</li> <li>• High glare from direct and reflected sunlight</li> <li>• Dust storms</li> </ul>	<ul style="list-style-type: none"> <li>• High ambient temperature, humidity and solar radiation</li> <li>• Thermal discomfort due to high humidity levels</li> <li>• Flood hazards</li> </ul>
<b>Microclimate design</b>	<ul style="list-style-type: none"> <li>• Compact forms</li> <li>• Shade and shelter for public spaces</li> <li>• Glare control: roughness and low reflective colours</li> <li>• Evaporative cooling: by strategic inclusion of vegetation</li> <li>• Windward location close to water bodies if feasible</li> <li>• Protected urban edges from hot winds</li> <li>• Narrow winding roads and alleys, and mixed building heights</li> </ul>	<ul style="list-style-type: none"> <li>• Provide good airflow conditions around buildings</li> <li>• Wide open streets and dispersed forms provide good ventilation</li> <li>• A variation in building heights encourages more ventilation</li> <li>• Wide open spaces with tree zones providing shading</li> <li>• Design for effective rainwater runoff</li> <li>• Rain shelters in public areas</li> </ul>
<b>Building Design</b>	<p><b>Orientation:</b></p> <ul style="list-style-type: none"> <li>• Windows facing mainly north and south with overhangs or external shading</li> </ul> <p><b>Building form:</b></p> <ul style="list-style-type: none"> <li>• Compact geometry reducing skin area</li> <li>• Buffer zones and thermal zoning</li> <li>• Daylighting zones</li> <li>• Night cooled mass systems</li> <li>• Evaporative cooling towers</li> </ul> <p><b>Materials:</b></p> <ul style="list-style-type: none"> <li>• Roof with High SRI</li> <li>• High thermal mass</li> <li>• Exterior insulation for reducing heat gains during the day</li> <li>• Windows. VLT &gt; 60% for good daylighting</li> </ul>	<p><b>Orientation:</b></p> <ul style="list-style-type: none"> <li>• Windows facing mainly north and south with overhangs or external shading</li> <li>• Opening windows towards prevailing breezes</li> </ul> <p><b>Building form:</b></p> <ul style="list-style-type: none"> <li>• Open and permeable geometry allowing air movement</li> <li>• Courtyards</li> <li>• Buffer zones and thermal zoning</li> <li>• Daylighting zones</li> </ul> <p><b>Materials:</b></p> <ul style="list-style-type: none"> <li>• Roof with High SRI</li> <li>• Low thermal mass</li> <li>• Windows VLT &gt; 60% for good daylighting</li> </ul>

**Figure 43: Psychometric charts for Kano (up) and Lagos (down) outlining thermal comfort hours with the main passive strategies outlined**

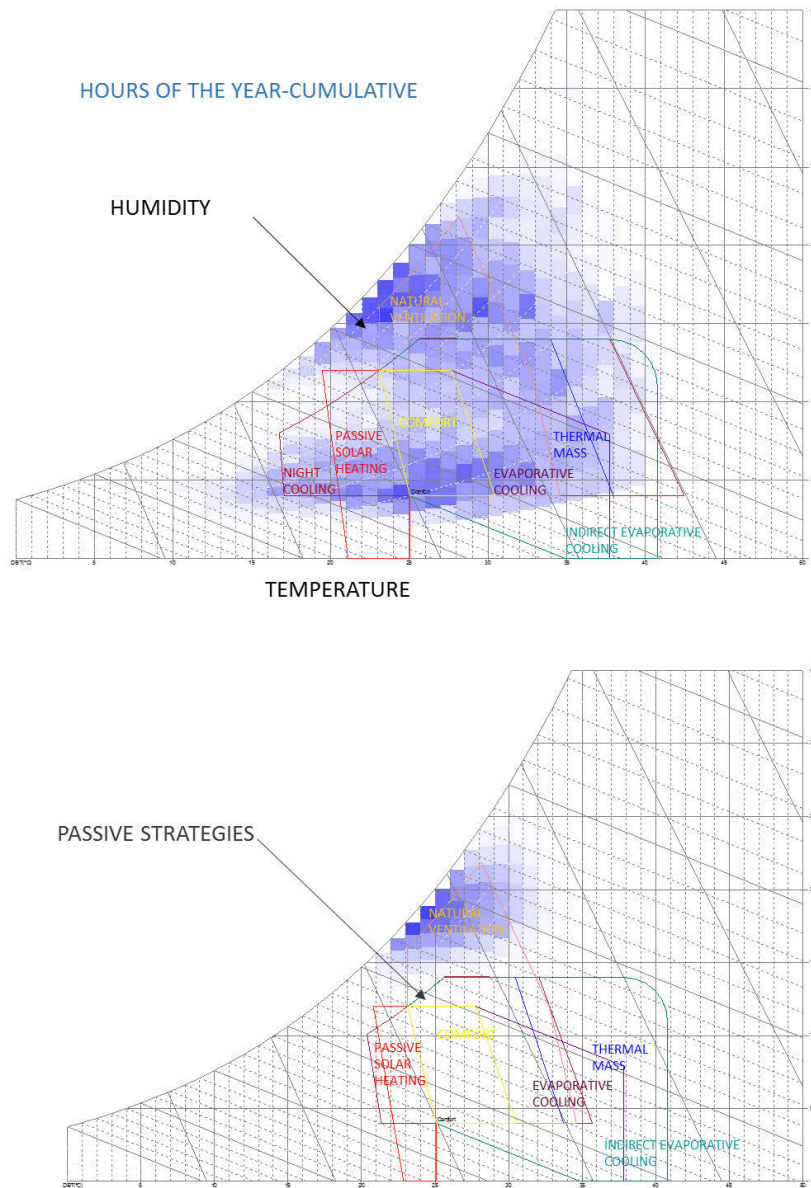

The psychometric charts above show the annual weather data for Kano (hot&dry) and Lagos (hot&humid) in blue against axes of temperature (horizontal) and humidity (vertical). The chart also shows conventional comfort conditions (the yellow zone) and how those comfort conditions can be

expanded with various low energy measures as discussed above. The charts clearly illustrate the range of passive measures which are suitable for hot and dry climates but will not provide benefit in hot and humid climates.

# 06 Active Systems

## 6.1 Chapter Summary

This chapter addresses the active mechanical and electrical systems in buildings and suggests ways in which they can be made more energy efficient.

In Nigeria, cooling and lighting are the main contributors to the energy demand in buildings.

In terms of cooling, once passive strategies have succeeded in alleviating external heat sources, the next step is to reduce internal gains such as those from lighting and equipment. This reduces cooling demand which should be matched with energy efficient cooling systems.

## 6.2 Efficient VAC systems

Once the cooling demand has been reduced, the simplest active cooling strategy would be promoting air movement via ceiling or desk fans, especially in residential buildings where cooling is not usually installed.

For air conditioned buildings, the mechanical equipment should be sized in response to the actual demand and energy efficient systems for cooling production, ventilation and distribution. The measure of performance of cooling systems is the coefficient of performance (COP) which varies from about 2.5 for split AC units, to around 3-3.5 for Variable Refrigerant Volume (VRV) units to around 4-5 for high performance air cooled chillers. The inclusion of building controls provide additional energy savings.

### Efficient lighting and equipment

Lighting is one of the systems where large improvements can be achieved. Simply changing lamps from incandescent bulbs to compact fluorescent or LED results in significant energy savings, especially in the residential sector, where lighting is one of the major energy uses. The addition of daylight and occupancy controls provide an extra level of saving which are recommended in office buildings.

Appliances (e.g. fridges, washing machines, televisions etc.) are another important load, particularly in the residential sector. Consumer labelling of many appliances is now compulsory in Europe and many other countries like South Africa to enable consumers to make choices on the basis of energy efficiency.

### Back up generation

The electricity shortages and the low capacity of the grid, mean that most people rely on private generation for a significant number of hours a year. Small petrol and diesel generators are widespread and are a very inefficient method of generating electricity. Their efficiency can be improved by the addition of energy storage (e.g. batteries). This means generators can be run at full load during the evening (when they are most efficient) but switched off overnight avoiding the running noise.

### Commissioning

Correct testing and system operation is crucial for maximising the benefits of good design. Commissioning should be performed by qualified personnel and the occupant educated on how to operate any systems. Several building certification

programs require that an independent commissioner be included in the owner team so they can review the project energy goals and be an active member in the Integrated Design Process.

### Energy Efficient VAC Systems

The most effective way to reduce VAC systems energy consumption is to reduce the heat load predominantly via measures described in the bioclimatic design section. On top of this, we can further reduce the cooling load by selecting more efficient systems or adjusting operation criteria.

Common strategies are depicted below.

#### Air movement

##### Ceiling and desk fans

Ceiling and desk fans cause air movement which helps the skin cool down. Therefore, sitting under a fan feels cooler even though the air temperature is the same. Ceiling fans consume much less energy than air conditioning systems.

#### Cooling via humidity control Hot & humid climate

In the hot & humid climate, a potential first step for small buildings where mechanical cooling is included, is to provide cooling via humidity control.

##### Dehumidification systems

**Enthalpy Reclaim:** A rotating wheel containing a desiccant material between the supply and exhaust airflows allows the exhaust air to cool and dehumidify the incoming fresh air, thus reducing the cooling load.

Figure 44: Dehumidification Systems

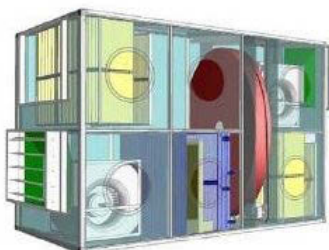

**Desiccant dehumidification:** Desiccants are materials which absorb moisture from the air. Once they become moist, they must be heated and dried out before they can be used again. It is possible to use solar energy to dry the desiccant, in which case the system becomes quite energy efficient, although such units are not yet widely available.

#### Cooling via humidity control

##### Hot & dry climate

In hot & dry climates, cooling can be provided by evaporative cooling systems, which remove heat from the air via evaporation.

##### Evaporative systems

**Evaporative Cooling:** In a simple evaporative cooling system, outside air is drawn through wetted pads and then supplied into the room. As the water evaporates, it draws heat from the surroundings, making the internal space cooler (but also more humid). This technology is therefore only effective when the outside air is fairly dry.





Figure 45: Evaporative Systems



**Indirect evaporative cooling:** A variation on the simple cooler above is when exhaust air is humidified and then used to cool the incoming fresh air via a plate heat exchanger. This then provides some cooling without increasing the humidity in the space.

#### Efficient cooling systems

The efficiency of a cooling system is often measured using the COP. This is a ratio of the cooling output (in kW) at certain defined conditions, relative to the electrical power consumed (also in kW). The following table depicts the most applicable systems and recommended efficiencies:

Table 9: COP of cooling systems		
System	COP (approx.)	
Split systems	2.5	
Inverter driven split systems	3.0	
VRV systems	3.0-3.5	
Air cooled chillers	4.0	
	6.0	
	9.0 or more	

There is a range of cooling systems which can be considered in a typical office building. These range from VRV systems, to chilled water fan coil units, to potentially lower energy systems such as displacement ventilation via a raised floor and chilled beams.

Another type of air conditioning worthy of consideration is the Variable Air Volume (VAV). This system functions by distributing cooled air (either mechanically cooled or drawn from outside air) to each space. The main advantage of this is that in some climates, it allows fresh air to be used with no cooling when outside conditions are favourable. However, in Nigeria, the outside temperature is rarely cool enough for this, and for this reason VAV is unlikely to be energy efficient. The disadvantages of VAV include the need for large ductwork in each space, and the fact that individual space control often relies on reheating the cool air which is inefficient.

The use of R22 refrigerant is still widespread in Nigeria. This has been outlawed in Europe due to the damage it causes to the Ozone layer and its high GHG potential if released into the atmosphere. Other refrigerants such as R134a and R407c should be prioritised when specifying new equipment.

**Fan and AHU efficiency**

The efficiency of an AHU is usually measured by the Specific Fan Power (SFP). This is a measure of the electrical power (in Watts) used to provide 1 litre/sec of air. Typical values are around 2 to 3 W/l/s. Clearly, the lower the SFP, the less energy is used to provide fan air. The best way to obtain a lower SFP is to slow the air velocity through the air handling equipment, which means increasing the size of the fans and ductwork. Other measures, such as using electronically commutated (EC) motors will also help, as well as ensuring filters are kept clean.

**Other VAC efficiency measures**

**Insulation of pipework**

Whatever the system, it is important that basic energy efficiency measures are used such as applying effective insulation (with vapour barriers) to all cold pipework and ductwork.

**Figure 46: Closed cell elastomeric foam insulation which offers good vapour performance as well as thermal insulation**



**Figure 47: BMS interface for controlling temperature set point etc., and simple time clock**



### 6.3 Controls and BMS

Controls are vital to ensure equipment is only operated when needed and is always running at the most efficient setting. A simple wall mounted thermostat/controller can be an effective form of control, especially in cellular offices, provided that the occupants realise the importance of switching systems off when leaving in the evening. Open plan areas are more difficult, since thermostats are often left on the maximum setting (i.e. 16°C) and equipment is left running all night. Most modern VRV systems are designed for centralised system control, which allows, for example, the maintenance manager to switch off all units at 7pm and reset the set points to 24°C, a temperature that is more aligned with the adaptive comfort approach. Other plant (fans etc.) can similarly be run on a time clock.

In more complex buildings, it may be appropriate to have a Building Management System (BMS). This is a computer based system to control fans, valves, dampers etc. based on temperature, occupancy, wind direction etc. Such systems can also gather data from electricity and water meters. This allows for very flexible control and monitoring of the building. The downside of such systems is the current lack of maintenance capacity in Nigeria which would make it very expensive to install and challenging to operate without proper training and technical support, particularly if experiencing malfunctioning. BMS systems should therefore only be used when it is clear that the building occupant will have the necessary resources and expertise to operate them.

### 6.4 Energy Generation and Storage

In Nigeria most buildings rely significantly on electricity generated on site due to deficiencies in the mains supply. While this energy would ideally be generated from a renewable source (see chapter 7 of this guideline), this will not always be possible due to capital cost constraints. The traditional back up power source for large buildings is from diesel generators and petrol generators for small domestic buildings.

Small petrol generators typically have an overall efficiency of around 17% when running at full load, but this drops to around 13% at half load, and even lower at very low loads. These efficiencies are far below those of a commercial power station, even after accounting for losses in the distribution system. Small petrol and diesel generators therefore are very inefficient methods for generating electricity, but are popular due to their low capital costs and small size.

**Figure 48: Small petrol generator and various battery options**



The performance and efficiency of small generators in domestic houses can be improved by the addition of energy storage (e.g. batteries). This allows the generator to be run at full load for a few hours in the evening to cover both the peak demands and also charge up the batteries. Subsequently, the batteries can supply power during the night and during times when the load is low thereby avoiding running a generator all night long just to power one or two air-conditioning units. For more information on batteries please refer to chapter 7 of this guideline.

Larger diesel generators are more efficient at around 35% overall efficiency, which demonstrates that several apartments or buildings can be powered from a single generator which will lead to improved energy efficiency.

## 6.5 Energy Efficient Lighting and Equipment

### Lighting design

The most energy efficient option is the use of daylight, provided this is carefully designed to avoid solar gains and glare as explained in the previous chapter.

The first stage of lighting design is to decide on an appropriate lighting level, measured in lux. While in the past high light levels such as 500 lux were often specified for offices, it has been acknowledged that this is excessive and wasteful of energy, as more people are now using computers rather than paper and pen, and lower levels of typically 300-350 lux have been adopted. This can be supplemented by desk lights to provide task lighting for very detailed tasks which require higher light levels.

For external lighting, a balance has to be made between low light levels for energy efficiency, and adequate lighting to give a sense of security. Once the desired light level has been chosen, a variety of free software such as “Dialux” can be used to design the installation. The colour of the walls and ceiling will have a significant effect on light levels, and darker colours should generally be avoided for large areas.

Up lighting, when the lighting is directed onto the ceiling and “bounces back” into the room, gives a pleasant and even lighting distribution, but is not as efficient as direct lighting. A combination of down and up lighting is recommended by most design guidelines (CIBSE, Lighting Guide LG7: Office Lighting, 2005).

### Artificial light sources

Graph of luminaires and efficiencies

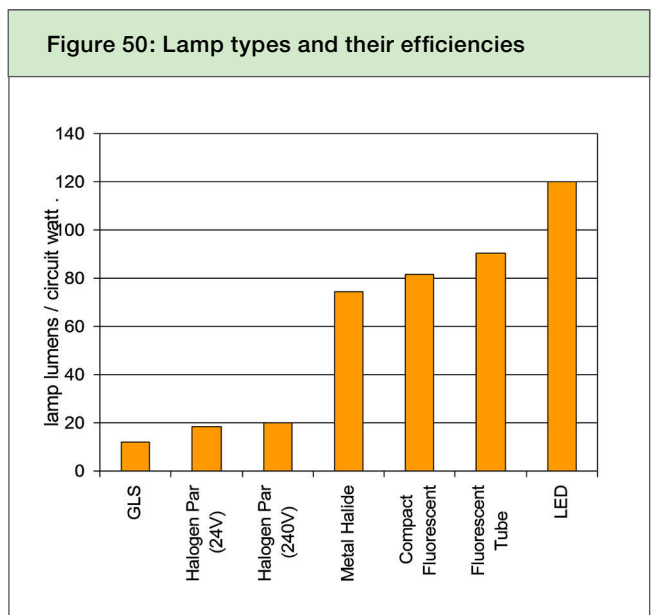
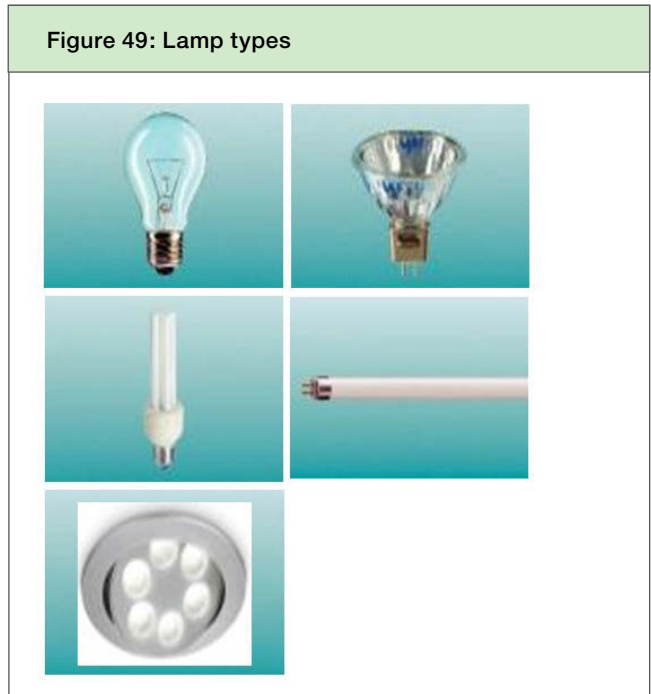



As shown by the graph above, fluorescent lighting is much more efficient than incandescent lights. Despite higher capital costs, the fluorescent lights will usually payback in under a year due to the reduced electrical costs to run them.

Light emitting diodes (LEDs) are now becoming widespread, and while efficiencies vary, many are now even more efficient than fluorescent lights. With a very long lifetime, it is expected that LEDs will become more and more common in both houses and office buildings. LEDs are already widely used in street lighting and other external applications.

Using efficient lighting, it should be relatively easy to achieve lighting loads of around 10W/m<sup>2</sup>, and with more effort and for example using LEDs, loads down to around 5W/m<sup>2</sup> are possible.

### Lighting controls

Another way to reduce lighting energy usage is through effective controls. At their simplest, this is just providing manual switches to each zone of lights which are clearly labelled and positioned close to the occupants to make it easy for them to switch them on and off. The Green Star rating (South Africa) suggests that lighting zones should not exceed 100m<sup>2</sup> of floor area.

Presence detection is a simple and effective form of control especially for toilets and rooms which are rarely occupied. Here a passive infra-red (PIR) sensor is linked to the light, and switches on the light for a fixed time period when any movement is detected. These controls can be unpopular in office areas since if someone is working at a desk there may not be enough movement to trigger the sensor and the lights may be switched off while the person is working. More sophisticated self-contained fittings are available which in addition to dimming when no movement is detected also dim in response to daylight levels.

At the extreme end of the scale, computerised lighting control systems are able to control each light individually (addressable lighting) to allow for centralised controls with local overrides. Such systems can also raise and lower internal blinds and adjust moveable external shading to suit weather conditions.

External lighting can be controlled using photocells which turn on the light when the ambient light level falls. In combination with time clocks this may offer the opportunity to reduce light levels after say, 10pm, to give additional energy savings.

## 6.6 Efficient Equipment

In a modern office, a significant percentage of the building energy use is for IT equipment such as computers, servers, etc. Efforts should be taken to select equipment that are more efficient. For example, modern flat screens consume a lot less power than the old CRT screens. Laptops and tablets also consume significantly less power than desktop computers. Software is available which automatically and safely shuts down computers at night in case staff forget to do so before leaving.

## 6.7 Metering

In order to optimise a building once it is operating, it is necessary to have good data on how energy is being used. It is recommended that sub-meters are included in all large buildings, typically at least one per floor and for large pieces of equipment (e.g. over 50kVA) such as chillers. Systems are available to make consumption information available to all building occupants via real-time “dashboard” websites, which can have very positive effects on people’s behaviour as well as informing the building Facility Management team.

## 6.8 Commissioning

Once the mechanical and electrical systems of a building have been installed, it is vital that they be properly tested and commissioned. In the rush to complete a project and hand it over to the client, these steps are often overlooked, and result in buildings which are never operated in their design potential.

Guidance on commissioning can be found in various CIBSE codes. It is particularly important for large and complex systems such as chilled water systems, but even relatively straightforward VRV systems need to be carefully tested to ensure they are working as intended. It can also be beneficial to “re-commission” a building after a period of say, one year, to ensure that everything is still running as intended, and if otherwise, to understand why and to correct the problems.

Once the building is occupied, failure to carry out regular preventive maintenance will result in reduced equipment life expectancy, plant failures, inefficient running and discomfort for the building occupants. Clients need to consider operation and maintenance of their building from very early on in the design process. There is significant benefit from the Facility Management team being involved in the early stages of design when they are able to explain their requirements to the design

team. Similarly it is important that the architect and designers consider how the building is to be maintained, and provide safe and easy access to all pieces of equipment which will need regular maintenance. This can benefit all parties, for example designing solar shading systems which can also be used as access platforms for cleaning glazing.

The design team and contractor can also assist the building operator by preparing accurate Operation and Maintenance manuals. This should include recommended preventative maintenance procedures, where to obtain spare parts, emergency procedures and similar issues.

In more complex buildings, a simple and readable “Building User’s Guide” can be invaluable in informing general users how to operate the building, how to save energy and water, how to sort their waste for recycling, options for public transport to the building, local shops and so on.

# 07 Renewable Energy Technologies

## 7.1 Chapter Summary

Renewable energy can be defined as energy whose source is replenished naturally on a human timescale. Once demand has been reduced by passive design and the necessary mechanical and electrical systems have been designed and

selected to optimise their performance and efficiency, energy generation from RE sources can further improve building performance. This chapter provides an overview of renewable energy technologies applicable in Nigeria and provides insight on the process for technology selection, sizing and design, implementation and operation.

### Key Renewable Energy Strategies

<b>Photovoltaic (PV) Systems</b>	<p>Costs for PV have decreased rapidly over the years, and it is now financially viable in a wide variety of applications, especially for buildings which do not have a grid connection. Batteries required to store the energy are still expensive and have limited life-span, although it is hoped that this situation will improve in the coming years.</p> <p>There are different ways of connecting PV into a building, ranging from very simple systems with no batteries (suitable for borehole water pumping etc.) through to very complex hybrid systems incorporating diesel generation and battery storage. These are explored in more detail in this chapter.</p>
<b>Solar Hot Water (SHW)</b>	<p>Solar Hot Water (SHW) systems use sunlight to heat domestic water. Two main types are available, thermosyphon systems where the hot water cylinder is located at the top of the panel, and closed loop systems where the hot water cylinder is remote and water is pumped through the panels.</p>
<b>Wind turbines</b>	<p>Small scale wind turbines suitable for mounting on buildings are much less efficient than the large wind turbines used for commercial energy generation. They can also suffer mechanical damage during high winds, and generally require more maintenance than PV.</p>
<b>Bio fuel</b>	<p>Bio-fuel in the form of firewood is widely used in Nigeria, but is leading to deforestation and therefore is not encouraged. Bio-gas (methane) can be generated from organic waste and can be a useful fuel source especially in rural areas.</p>

**Figure 51: Solar hot water panels, PV panels, and small wind turbines.**

Image sources (left to right): © Sunflower solar, © Arup



## 7.2 Renewable Energy (RE) Sources in Nigeria

The main renewable energy source in Nigeria is solar energy. Solar resources are highest in the north of Nigeria, and lower in the southern coastal region. Nevertheless it is sufficient for solar energy viability. Other potentially viable renewable energy resources in Nigeria include wind and bioenergy. Different renewable technologies feature different characteristics of production, costs, scale, maturity, bankability, etc. and because of these reasons, a feasibility assessment should be performed for each potential site to ensure it is both technically and financially suitable to install renewables.

## 7.3 Photovoltaic

The production of a solar energy system is heavily dependent on the amount of incoming solar energy, referred to as solar irradiation or more generally as solar resource. A system located within a site with greater solar resource will generate more energy (either thermal or electrical, depending on the technology) than an equivalent system located within a site with less solar resource.

Nigeria is fortunate to have sufficient solar resource to make solar energy technologies an attractive solution for renewable energy supply in most of the country.

Figure 52 shows the annual average global horizontal illumination (GHI) values for Nigeria. While there is a fairly significant difference in the solar resource available in the southern and northern regions, the lower levels of solar resource within the country are sufficient for solar energy viability.

**Figure 52: Global horizontal solar radiation in Nigeria. Source: Solargis<sup>15</sup>**

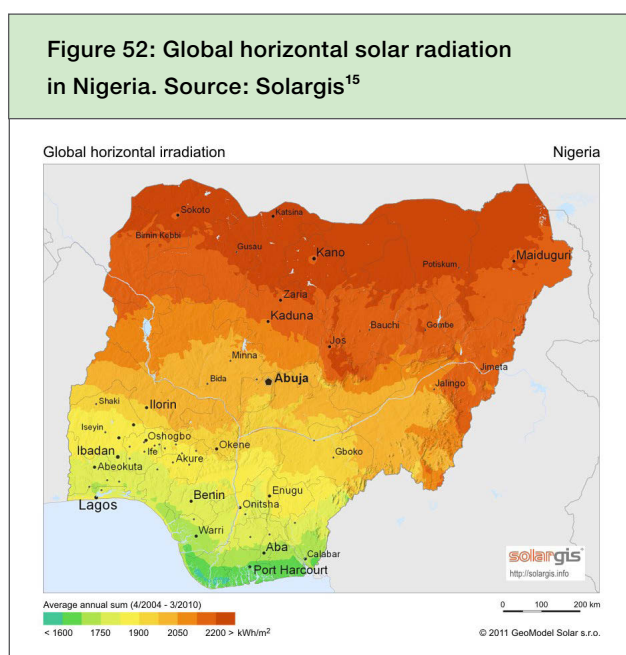

A PV system comprises a variety of different components and provides direct current (DC) or alternating current (AC) depending on the complexity of the system. For example, a solar pumping system may involve simply a solar PV module and a DC pump motor, whereas a complex system that is connected to an unreliable grid may contain several strings of PV modules, an inverter and an inverter/charger, a battery bank, various disconnects and fault protection devices, etc. In general, the main configurations for PV systems relevant to this document will likely include the following:

15. <http://solargis.info/maps>

Table 10: Sample PV systems

Typical PV arrangements

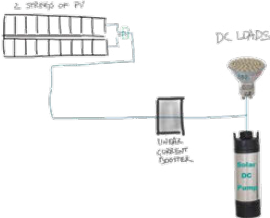
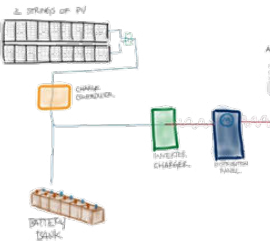
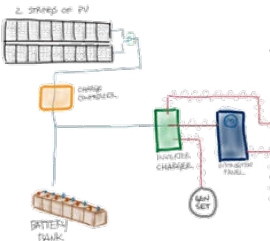
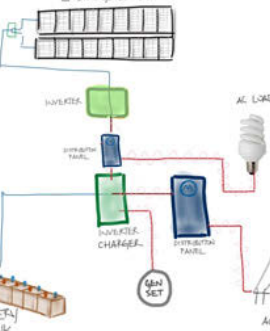
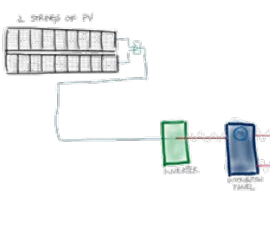
<p><b>DC-only PV system</b></p>	<p>Very simple and cheap – good for borehole pumping</p>	
<p><b>Off-Grid, DC-coupled</b></p>	<p>Good solution for residential and other fairly small buildings without a grid connection.</p>	
<p><b>DC-coupled Battery Backup Grid-Tie</b></p>	<p>Good solution for residential and other fairly small buildings with a grid connection.</p>	
<p><b>AC-Coupled Battery-Backup Grid-Tie</b></p>	<p>Generally the ideal solution for medium to large systems.</p>	
<p><b>Utility-Interactive (aka Grid-Tie)</b></p>	<p>Best solution with stable grid connection and grid policies that permit net metering (export and import to and from the grid).</p>	

### Future trends for decentralized energy: micro grids

A micro grid is a local energy system which incorporates three key components: generation, storage and demand, all within a bounded and controlled network. It may or may not be connected to the grid.

Nearly all solar PV systems require either a connection to an external electrical grid or the integration of an on-site battery and inverter/charger that together create a micro grid. There are regulatory and safety issues with connecting to the national grid, since, for example, if the PV exports power to the grid during an outage it could cause electrocution of utility line workers. In many developed countries, people are encouraged to feed electricity into the grid and are rewarded with generous “feed-in tariffs” for any electricity exported, and such legislation exists in Nigeria for small/medium scale applications.

In an office building, the demand for electricity may well coincide with daylight hours which is when the PV will be generating electricity. Depending on the size of the PV array, it may well be possible to use the electricity directly without needing batteries, which substantially reduces the capital costs. In this case, backup diesel generators (gensets) would still be required, and the PV would be synchronised with the generators or national grid depending on which is operating. However, it must be noted that coupling PV systems into genset micro grids can be tricky, as care must be taken to ensure adequate spinning reserve is available at all times to cover fluctuations in the PV output (e.g. due to a passing cloud). The gensets must also always be operating at levels greater than their manufacturer-suggested minimums (typically 30-40% of their capacity). Solar + diesel hybrid micro grids are generally most reliable and stable when the solar PV system satisfies only a small minority of overall energy demand.

### Batteries

In most buildings where consumption profiles are different from the PV generation profile, batteries will be required to get best utilisation of the PV energy. In standalone systems, the battery is arguably the most critical component. It stores energy when there is more generation than demand, and discharges energy when the demand exceeds the generation.

Currently, lead-acid batteries are the most dominant established technology in stationary electrical storage, particularly on smaller scales. For energy storage applications, deep discharge lead acid batteries should always be used (not car batteries which have a very short life-span if repeatedly charged and discharged). Longer lifetimes can be achieved by providing more batteries and thus reducing the depth of discharge (DoD) of the batteries. Batteries form a significant proportion of the PV system capital cost, hence the choice of the days of autonomy (DoA) and DoD are key decisions in the design process. Typically, battery banks should be located indoors in well ventilated spaces and larger systems can require significant footprints.

Research and development of new battery chemistries is skyrocketing and several new and exciting technologies show promise to unseat lead-acid as the economical favourite, such as saltwater (e.g. Aqueon Energy4F<sup>16</sup>), flow batteries (e.g. Imergy5F<sup>17</sup>) and Li-ion (e.g. Tesla6F<sup>18</sup>).

**Figure 53: Flooded deep discharge lead-acid battery bank feeding three SMA Sunny Island inverter/chargers. Image Source: © DreamPower Solar.**



<sup>16</sup>. [p://www.aquionenergy.com/energy-storage-technology](http://www.aquionenergy.com/energy-storage-technology)



<sup>16</sup>. <http://www.imergy.com/>

<sup>16</sup>. <http://www.teslamotors.com/powerwall>

## 7.4 Solar Hot Water Systems

Very simple methods exist to heat water using solar energy, for example passing the cold water through black

plastic pipe on the roof, or putting the hot water cylinder directly in the sunlight behind glazing. However, two main types of solar heating systems are commercially available, and are discussed in the following figure:

Thermosyphon	Closed loop active
<p>Likely to be the most common of all SHW systems globally, the thermosyphon system is an open-loop passive system that is extremely simple.</p> <p>Natural convection drives the process, with the water heated within the collector naturally rising up to the tank and forcing the colder water down into the collector below.</p> <p>The solar collector is commonly a glazed flat plate, which is the simplest and cheapest option. In countries with cold weather, evacuated tube collectors offer some benefits, but since these are more expensive, they are unlikely to be the best solution for Nigeria.</p>	<p>The typical closed loop active system utilizes a self-contained, closed circuit with a pump that absorbs the thermal energy from the collectors and transfers it to the separate hot water storage tank.</p> <p>These require a more sophisticated design but enable superior control and performance, and are appropriate for larger scale installations such as a hotel.</p>
<p><b>Figure 54: Thermosyphon system</b></p>	<p><b>Figure 55: Close loop active system</b></p>
 <p>© Green Roof Solar</p>	 <p>© Keen Technical Solutions, LLC</p>

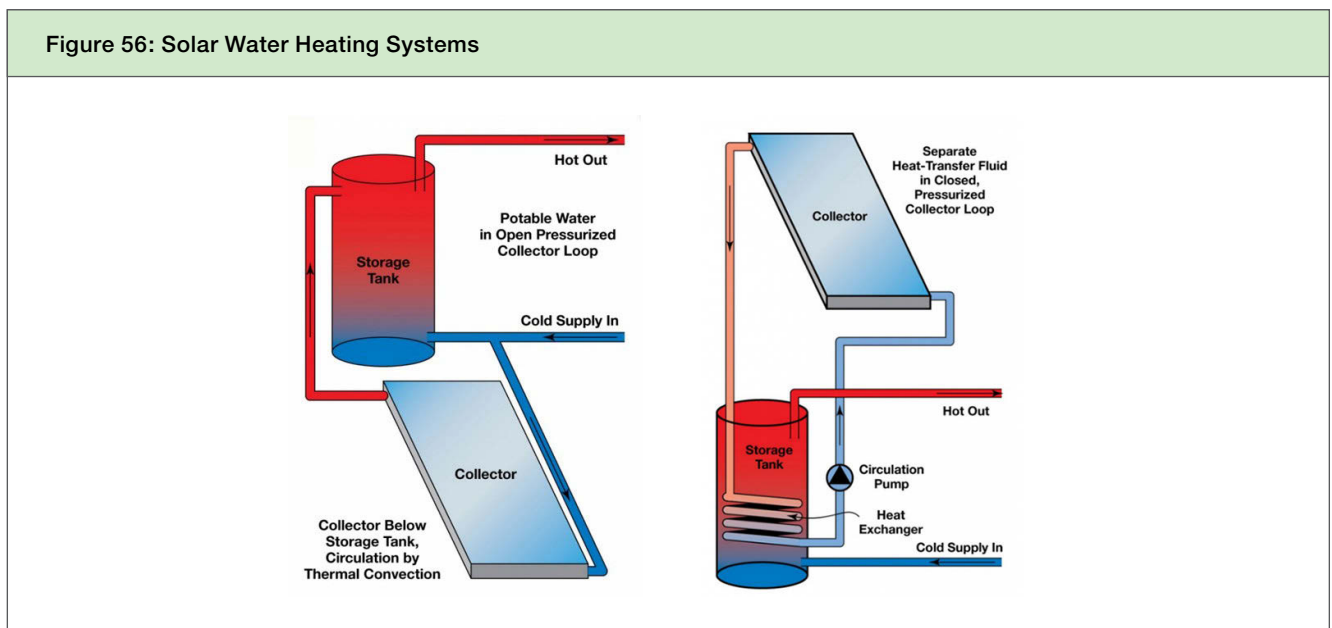

**Figure 57: Air source heat pump used to heat domestic water. Image source: © Mitsubishi**



In general, collectors should be mounted facing the equator (which in Nigeria means having an azimuth facing south) with a tilt angle at or near the angle of the location's latitude.

Many solar hot water systems incorporate backup electric heating elements within the hot water cylinder. Correct control of these heaters is essential. If left on all the time, the electric heater will simply keep the water hot at all times and negate any heating from the sun.

As an alternative to solar water heating, air source heat pumps can be used to heat water and achieve a better efficiency than simply using electricity to directly heat water.

## 7.5 Wind Turbines

Wind turbines create electricity by converting the kinetic energy of wind into rotational energy of the wind turbine rotor, which in turn causes a generator to spin and create electrical energy.

Wind turbines are effective, reliable, and proven on a large utility scale. However, on a smaller scale, they are often less effective. This is mostly since airflow near buildings tends to be turbulent and wind turbines require high quality laminar wind flow for best performance. Small wind turbines are generally only cost effective when sited away from obstructions such as trees and buildings, which generally excludes them from urban applications.

A study in the UK covering 26 small wind turbines located on buildings (Encraft, 2009) showed that the vast majority generated far less than the manufacturer's claims, and also

**Figure 58: Darling Wind Farm, South Africa © Warrenski**



a large number of turbines were inoperational for long periods due to maintenance problems and complaints from nearby residents.

## 7.6 Bioenergy

Bioenergy is energy produced from renewable, biological sources such as biomass. Biomass is biological material, derived from living (or recently living) organisms, that can be turned into fuel (also known as biofuel when it is made from biological material) to supply heat and electricity. Examples of biomass materials include: wood, grass and other plants, forest and crops residues, etc.



Figure 59: Firewood sourcing: Image source© Polio Nigeria



## Wood

Wood is widely used in Nigeria for cooking and heating water, but unfortunately the rate of consumption far exceeds the replenishment rate and is leading to deforestation.

Figure 60: Biogas Generator by Pioneer. Source: © SuSanA Secretariat



## Biogas

It is possible to generate biogas (largely methane) from anaerobic digestion of organic waste, and this has been used successfully in some Sub-Saharan countries. Examples in an urban setting include abattoirs and vegetable markets, which both create significant organic waste.

The biogas can then be used for cooking or other purposes.

# Regional Hazards Affecting Building and Systems Design

## 8.1 Chapter Summary

Nigeria is affected by various natural hazards across the country. Heavy rains, dust storms, the Harmattan, insects and termites etc. pose some additional challenges in the implementation of the strategies outlined above.

It is expected that design practitioners in Nigeria are already aware of these hazards, but this section identifies how energy efficient design may lead to new risks and how they can be mitigated.

## 8.2 Regional Hazards

### Sand and dust

The Harmattan brings hot air and dust, which may interfere with natural ventilation strategies. Dust must be taken into account when designing natural ventilation strategies. It may also be appropriate to use sand louvers when designing air conditioning systems.

Sand also affects the performance of solar systems, requiring continuous cleaning and maintenance to guarantee the proper performance of the system. Safe access must be provided to allow easy cleaning of rooftop solar panels.

### Condensation and mould

High humidity levels bring the risk of mould formation which poses a risk to human health. When insulating walls, it is common in Europe to include vapour barriers in the construction. However, in Nigeria this could lead to condensation occurring within the building fabric (interstitial condensation) unless care is taken to avoid this and ventilate any cavities where condensation may occur. In general, it is better to use slightly permeable (breathable) materials which allow some transfer of moisture through them.

If air conditioned buildings rely on fresh air entering through permanent vents or open windows, there is a risk of condensation since the warm humid air will condense on the first cold surface which it encounters. It is therefore usually preferable in air conditioned buildings to seal the façade and provide tempered and dehumidified fresh air by mechanical means.

Key Findings	
<b>Passive strategies and risks</b>	The selection and implementation of green strategies must consider the durability and resiliency of constructions. Dust and humidity can make difficult the implementation of measures such as natural ventilation. A durability study should be added to the decision making process to mitigate the risks associated with these hazards.

## Heavy rain

Heavy rain causes flooding which requires additional design strategies to be included in the passive design. For example critical and delicate equipment such as inverters and batteries must be sheltered and elevated above the flood levels.

## Security

Operable windows and external shading systems can be seen as a security risk. In practice it is usual to avoid external shading on the ground floor of buildings which helps reduce the risk of people attempting to climb any shading systems. Anti-climb coatings could also be considered if it is thought there may be a significant security threat.

Figure 61: World lightning frequency map

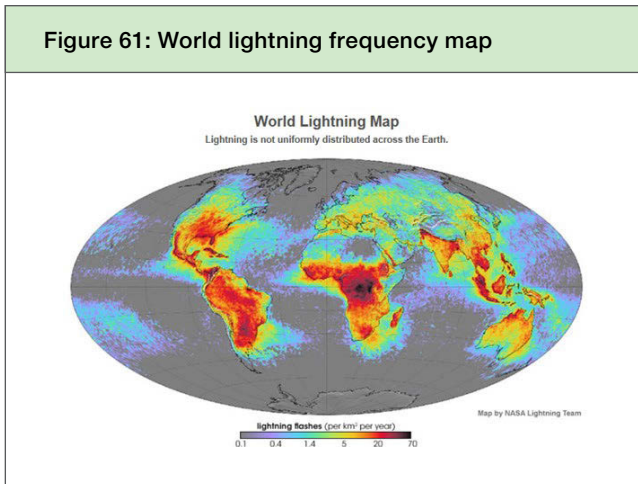

## Lightning

Lightning is very common in the Equatorial zone, and a strike brings risk of fires as well as damage to electrical and computer systems. It is normal to assess the risk to a building using the method outlined in BS 62305 / BS 6651, and if necessary, provide a lightning control system.

## Insects, termites

Vents into roof voids and similar must be designed to prevent pest ingress. Similarly, it may be appropriate to use mesh on window openings, especially those which are intended to be left open at night, since insects will be attracted to any lights inside the building. While using timber for construction has low embodied energy, the risk of termite attack must also be considered.

# 09 Tools for Designing Energy Efficient Buildings

## 9.1 Chapter Summary

Numerous tools have been developed across the world to help the decision making process, guiding design teams and future occupants. This section includes a preliminary shortlist of tools that can contribute to green building design. The following tools are reviewed in more detail:

Whole Building Design Tools:

- Athena
- Green Building Studio
- Eco-Bat
- IES Virtual Environment

Energy efficiency tools:

- eQuest
- Energy Plus
- DesignBuilder
- Passive House Planning Package

## 9.2 Whole Building Design Tools

### Athena

This is a decision support tool that assists in making informed environmental choices. The tool aids the selection of materials and other design options to minimise a building's potential life cycle environmental impacts and foster sustainable development.

Athena model provides a cradle-to-grave Life Cycle Inventory, which provides outputs in terms of consumption of energy, raw materials, as well as emissions of pollutants to air, water and land. In addition, the model provides measures of the Global Warming Potential (GWP), Ozone Depletion Potential (ODP), Acidification Potential (AP), Smog, Human Health Criteria (HHC), Fossil Fuel Consumption (FFC) and eutrophication of the building over its lifetime.

Material manufacturing, including resource extraction and recycled content, transportation, on-site construction, maintenance and replacement effects and demolition and disposal, are the life cycle stages considered by this tool.

### Green Building Studio

This is an Autodesk cloud base software that links architectural building information models (BIM) with energy, water, and carbon analysis. It enables architects to calculate the operational and energy implications of early design including annual energy cost and carbon footprint specific to region and utility mix, renewable energy potential (PV and wind), weather data and user defined graphics, building and site specific natural ventilation potential and water and daylighting preliminary analysis for LEED®.

Green Building Studio life cycle assessment outputs are given as CO<sub>2</sub> emissions and energy consumption over a 30-year period.

## ECO-BAT

This is an environmental impact assessment tool covering the whole building life span. It allows inter-comparison of different variants of a material, an element or a building, definition of building systems and report impacts on: NRE (non-renewable energy), GWP, AP and Photochemical Ozone Creation (POCP).

Numerical and graphical results, globally, by elements, materials and phase can be obtained, with easy to visualise effects resulting from energy or material changes.

## IES-Virtual Environment

IES integrates Life Cycle Assessment with Life Cycle Cost, facilitating design and decision-making through coordinated approach to low-impact design.

This tool allows comparisons of embodied carbon or a particular solution against its operational benefit throughout the life cycle of the building.

IES characterises GWP, Water Extraction (WE), Mineral Resource Extraction (MRE), ODP, Human Toxicity, Eco toxicity to freshwater and land, nuclear waste, waste disposal, Fossil Fuel Disposal (FFD), eutrophication, formation potential of tropospheric ozone photochemical oxidants and acidification

Table 11: Overview of whole building tools

Tool	Strengths	Weaknesses
<b>Athena</b>	<ul style="list-style-type: none"> <li>High quality databases</li> <li>User-friendly interface</li> <li>Cradle-to-grave</li> <li>FREE</li> </ul>	<ul style="list-style-type: none"> <li>Limited to the materials selection analysis</li> <li>For structural materials and assemblies</li> <li>Developed regionally for Canada and USA</li> </ul>
<b>ECO-BAT</b>	<ul style="list-style-type: none"> <li>Detailed LCA analysis</li> <li>Based on the Eco invent database</li> <li>Wide choice of materials</li> <li>Regular database updates for licensed users</li> </ul>	<ul style="list-style-type: none"> <li>No validation method has been implemented (Eco indicator, EPS, etc.) yet.</li> <li>LICENCE FEE</li> </ul>
<b>Green Building Studio</b>	<ul style="list-style-type: none"> <li>Enables hourly whole building energy</li> <li>Carbon and water analyses early in the design process</li> </ul>	<ul style="list-style-type: none"> <li>Too detailed results</li> <li>The virtual environment is not user friendly.</li> <li>Reduced Life cycle output</li> <li>LICENCE FEE</li> </ul>
<b>IES-Virtual Environment</b>	<ul style="list-style-type: none"> <li>Comprehensive analysis across wide range of metrics</li> <li>Simulation results are linked between modules</li> <li>User friendly virtual environment</li> <li>Ability to undertake what-if assessments at design stage</li> <li>Outstanding interoperability with CAD/BIM platforms</li> </ul>	<ul style="list-style-type: none"> <li>Linux environment is not supported</li> <li>Engine simulation tools (Apache) are not open sourced, thus the calculation methods are not accessible to users</li> <li>LICENCE FEE</li> </ul>

**Table 12: Green and energy efficient design tools: Strengths and weaknesses**

Tool	Strengths	Weaknesses
<b>eQuest</b>	<ul style="list-style-type: none"> <li>• Whole-building annual energy performance</li> <li>• High execution speed that makes it feasible to perform many evaluations of large models</li> <li>• Captures critical interactions between building</li> <li>• Weather data for thousands of locations across the globe</li> </ul>	<ul style="list-style-type: none"> <li>• Non-automated compliance analysis for LEED® compliance</li> <li>• Does not support SI units (I-P units only)</li> <li>• Infiltration/natural ventilation and daylight models are simplified and limited</li> </ul>
<b>Energy Plus</b>	<ul style="list-style-type: none"> <li>• Complex modelling capabilities.</li> <li>• Independently tested</li> <li>• Input is geared to the 'object' model way of thinking</li> <li>• Weather files available for several locations around the world</li> <li>• Modular approach allows for additional modules</li> </ul>	<ul style="list-style-type: none"> <li>• Very complex and not user-friendly</li> <li>• Data input is text based</li> <li>• Requires extensive modelling experience and large learning curve</li> <li>• Large models can run slow</li> </ul>
<b>DesignBuilder</b>	<ul style="list-style-type: none"> <li>• Allows comparison of various design options for environmental comfort, energy consumption, daylight and natural ventilation</li> <li>• Based in Energy plus, models can be exported and further developed in this software</li> <li>• Results are detailed and accurate, exported to excel spreadsheets</li> </ul>	<ul style="list-style-type: none"> <li>• Limited default mechanical systems</li> <li>• Simulation can take long a long time, making iterative processed difficult for model for early design stages and decision-making</li> </ul>
<b>Passive House Planning Package</b>	<ul style="list-style-type: none"> <li>• Easy to use tool</li> <li>• Excel based and does not require simulation expertise</li> </ul>	<ul style="list-style-type: none"> <li>• Does not provide hourly, whole energy simulation tool which is not acceptable for most of the internationally recognised certification programs, such as LEED or BREEAM</li> <li>• Systems limited to conventional technologies</li> </ul>

### 9.3 Energy Efficiency Assessment Tools

#### eQuest

Using the DOE-2 simulation engine, eQuest was developed as a freeware tool designed to perform detailed energy analysis, even for critical decisions, including today's most sophisticated building energy use. The eQuest software can conduct whole-building performance simulation analysis throughout the entire design process.

Simulations include equipment and energy consuming devices performance as well as several end uses.

Graphic and tabulated results include energy cost estimation, daylight and energy system control, automatic implementation of common energy efficiency measures, as well as energy consumption.

#### Energy Plus

Simulation tool that features BLAST and DOE-2 capabilities, allowing design flexibility. This tool includes multi-zone airflow, electric power simulation of fuel cells and other distributed energy systems, as well as water manager rainfall, groundwater, and zone water use.

It does not include a graphical interface, therefore input is based on text, increasing the modeller effort. In the same line, energy and water results are available as spreadsheets and ASCII files for users to interpret and customise data visualisation.

#### DesignBuilder

User-friendly modelling interface from the Energy Plus tool, used for developing energy consumption calculations, internal comfort and VAC component sizes. DesignBuilder can be used for simulations of many common VAC types, naturally ventilated buildings, buildings with daylighting control, double facades, advanced solar shading strategies etc.

Energy consumption (by fuel and end-use), CO<sub>2</sub> generation amongst other results are based on detailed sub-hourly simulation time steps using the energy simulation engine.

Figure 62: eQuest building model

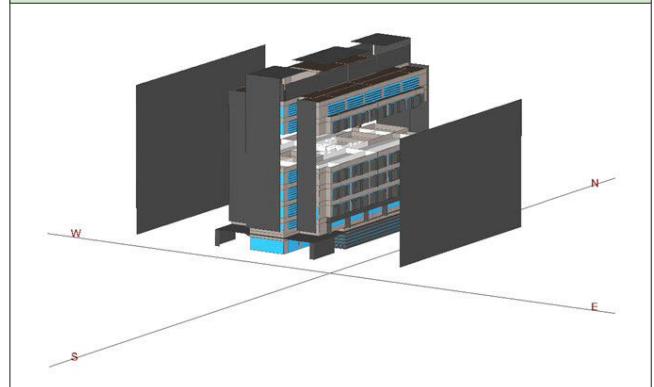
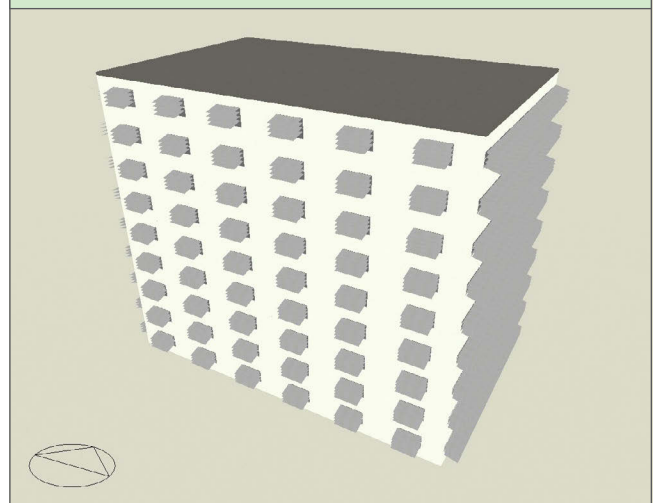

Figure 63: DesignBuilder model



#### Passive Hause (Passivehaus) Planning Package

Excel based assessment tool adapted for Mediterranean and hot climates offers quick basic energy assessment for early stages of decision-making, which makes this tool an easy-to-use approach during early stages.

Calculating energy efficiency for Passivhaus requires additional tools available at no cost and adapted for also for different climatic zones.

Currently, a 3D data entry and design modelling tool is being developed as a SketchUP plug-in. Table 12 highlights the strengths and weaknesses of each of the tools listed above.

# 10 Regulatory Framework

## 10.1 Chapter Summary

This section provides an overview of the current regulatory framework on energy efficiency in Nigeria. It identifies the current regulations, barriers and opportunities for improvement and the mechanisms needed for setting the groundwork for the implementation of energy efficiency measures in the design and construction standards in the building sector.

The energy and cost saving potential of energy efficiency standards can only be attained in practice if certain framework conditions are established.

The core element is an effective compliance and enforcement framework. However, there are other equally important aspects because they enable compliance and thus are paramount for the transformation of energy efficiency standards into actual practice. To summarise, the most important elements are:

- Legislation: Compliance and enforcement framework
- Availability of appropriate and cost-effective materials for construction and operation
- Qualified workforce for energy efficient building design, construction and operation
- Quality assurance
- Market demand for energy efficient buildings
- Access to finance
- Stakeholder involvement and acceptance – Moving forward together
- International Experience: Network and benefit

The guideline reviews international experience in developing countries. Their efforts and successful strategies have

allowed them to improve the building sector energy efficiency and reduce the demand, while increasing accessibility and resiliency of their energy sector.

## 10.2 Legislation: Compliance and Enforcement Framework

Minimum requirements addressing energy efficiency in buildings are usually part of the building legislation. In Nigeria, the building code is being revised to include energy efficiency. In this regard, the relevant compliance and enforcement framework is the one given by the building legislation. In this chapter, we briefly explain the concept of the National Building Code and the state legislation in place. We outline what further development will be needed to implement energy efficiency effectively in practice, once energy performance minimum requirements have been defined and also the supporting documents needed for declaration. In order to achieve energy efficiency targets, people must actually construct building plans that have been submitted and approved and not plans altered during construction after legislation has been satisfied.

### Building legislation: National Building Code and the state legislation

The National Building Code recently reviewed in 2013 is yet to be enacted into law by the National Assembly. This enactment into law will encourage states to adopt and enforce the National Building Code which is presently not the case, as states in Nigeria usually have local planning regulations for approval of building permits. Professionals in the Nigerian construction industry will need to be encouraged and trained to make use of the building



code by providing adequate incentives like reducing the time required to get a building permit. NESP supports the Federal Ministry of Power, Works and Housing (Housing) to integrate energy efficiency into the National Building Code with the aim of reducing the energy demand of buildings in Nigeria which will ensure better energy access and security for Nigerians.

### **Elements of an effective compliance and enforcement framework**

In order to achieve good compliance, societal support is important, meaning that stakeholders understand and accept the need for energy efficiency requirements, the need for compliance and the need to check and enforce compliance. Compliance can be achieved by rewarding if requirements are met or by penalising if requirements are not met. In many countries a combination of both options can be found.

Stakeholders respect clear enforcement procedures resulting in adequately severe sanctions being executed in case of non-compliance. Legal obligations without clear procedures in case of non-compliances usually lack practical implementation. Threat of penalties and other sanctions tend to be less effective if sanctioning procedures are not clear. First of all, sanctions should address the room for improvement detected during the compliance-check, not only to ensure compliance but also to contribute to quality assurance. Thus, apart from financial sanctions such as penalties, there are other types of sanctions, such as mandatory trainings for experts to improve the quality of energy efficiency measures.

### **There is a three-step approach to achieve good compliance and thus actual energy efficiency:**

- There should be clear procedures on how energy performance is determined (procedures address experts calculating the energy performance of buildings).
- There should be clear procedures on how to decide on non-compliance and related actions (procedures address officials in charge of approving the design and issuing the building permit).
- There should be effective control and sanctioning mechanisms to be applied in cases of non-compliance (what to do if building designs and the as-built situation do not comply).

A clear legal framework on how to detect and decide on non-compliance is a precondition for good compliance. Non-compliance can occur at different levels:

- Wrong reporting: there are problems in choosing input data for energy efficiency calculation, resulting in wrong energy efficiency declarations;
- Not meeting the requirements: wrong energy performance indicators can cause another type of non-compliance, e.g. not achieving the minimum requirements;
- No reporting: the energy declaration is not presented, although there is the legal obligation to do so.

In order to achieve good compliance, energy efficiency legislation must be unambiguous and include methods (e.g. random control of statistical sample) and responsibilities of checking compliance (e.g. third party control and/or carried out by public bodies) as well as sanctions to be applied in case non-compliance is detected. Well-designed compliance frameworks are effective, cost-efficient and simplify implementation for administration as well as for the construction and real estate sector.

Examples of methods of checking compliance include checking energy efficiency declarations on a full scale basis, carrying out random sample checks, certification of authorised experts issuing certificates, checks of supporting documents.

In Nigeria, responsibilities of checking compliance could be allocated to the authority mandated with issuing the building permit (check of planning documents) and Right of Occupancy (check of as-built situation).

Rewards in case of compliance could be a reduction of fees and access to a specific financing instrument created for the construction of energy efficient building. Sanctions in case of non-compliance could be the improvement of the design and the building respectively and attending mandatory training.

### 10.3 Availability of Appropriate and Affordable Materials for Construction and Operation

Nigeria's construction industry is growing rapidly and has the potential to be one of the biggest construction markets in the world. However, the construction industry faces a huge challenge to meet the new energy efficiency requirements the building sector demands, because new materials and products will be needed. At the same time, this is an enormous chance for innovative companies to win market share.

To ensure the availability of appropriate and cost-effective materials for constructing and maintaining energy efficient buildings, the co-operation between companies and the Nigerian Building and Road Research Institute<sup>19</sup> (an institute under the aegis of the Federal Ministry of Science and Technology FMST) is vital. The institute carries out research and is active in product development and testing.

Other options are signing a specific partnership agreement with energy efficient technologies (e.g. double glazed windows, insulation materials etc.) providers and making feasibility studies to produce specific products locally.

In this context, incentive programs/programmes to ease the access to efficient technologies are important, as well as quality assurance mechanisms to control imports of energy efficient systems. In this regard, quality labels are available and should be integrated in specifications for purchase/import, such as:

- Energy efficient lighting<sup>20</sup>
- Energy labelling for electric appliances<sup>21</sup>
- Energy efficient office equipment<sup>22</sup>
- Solar Key Mark for Solar Thermal Collectors<sup>23</sup>
- Certification of PV modules<sup>24</sup>

### 10.4 Qualified Workforce for Energy Efficient Building Design, Construction and Operation

A skilled workforce is crucial for improving energy efficiency in buildings. The need to develop capacity in sustainable design and construction is acknowledged in the Nairobi Declaration on Green Building in Africa, which affirmed the importance of training and certifying professionals, and introducing green building practices in the education system. For the construction industry in Nigeria to be able to service the economy and the building industry more effectively, well-trained and reliable

consultants and contractors with qualified and competent operatives are needed.

The continuous growth in technological know-how worldwide has led to new products and construction methods which are more demanding in terms of skills. Adopting these new technologies will help enhance sustainability and energy efficiency as well as labour productivity, among other benefits. However, this adoption of new techniques has to be aligned with an analysis of qualification needs, especially regarding unskilled workers and technicians. While respective content can be integrated to formal education and training schemes, specific training programmes (e.g. short on-site training) targeting the unskilled labour must be developed to cope with the increasing demand for better qualified workforce and the still large availability of unskilled workers in need of employment.

### 10.5 Quality Assurance

A quality assurance process is needed to make sure that what has been planned by the design team is actually delivered on-site.

Important elements of quality assurance regarding energy efficiency are:

- Check of design by registered expert (e.g. GBCN registered expert)
- On-site control by registered expert (e.g. GBCN registered expert)
- Commissioning of building by registered expert (e.g. GBCN registered expert)

Quality assurance results in extra cost during the design and construction phase, but will result in a better building and actual energy efficiency due to the fact that mistakes (such as design errors, mistakes during construction, using products different from the ones approved) will be avoided.

19. <http://www.nbrri.gov.ng/sites/index.php>

20. <http://www.premiumlight.eu>

21. <https://www.gov.uk/the-energy-labelling-of-products>

22. <http://eu-energystar.org>

23. <http://www.estif.org/solarkeymarknew/>

24. <http://www.tuv-pv-cert.de/en.html>

## 10.6 Market Demand for Energy Efficient Buildings

In Nigeria, population grew to 159 million inhabitants in 2010 and average electricity consumption was 149kWh per capita. (World\_Bank, 2014). This is very low compared to other countries in the world where the indicator is usually above 1,000kWh per capita, and over 13,000kWh per capita in the USA. An increase is necessary in order to achieve the development goals and meet suppressed demand for adequate energy services. The population is expected to grow at an average annual rate of 2.86% between 2000 and 2030 (Sambo, 2010) to 282 million. It is evident that this will generate an urgent need for housing construction and potentially skyrocketing energy consumption. There is currently a 16 million housing deficit and about 59 trillion will be required to provide the housing needs, whilst the growing number of sector reforms in Nigeria (Agriculture, Telecommunication, Energy) are leading to a greater demand for offices as international investors are on the increase (NESP, 2013) .

The urgent need for energy efficiency in buildings is clear, looking at the prosperous economic development, rapid population growth, the continued rural-urban migration and the suppressed demand for energy services.

In some sectors, international pressure may be put on organisations to become more energy efficient. For example in the banking sector, the Nigerian Central Bank has signed up to the Equator Principles which, amongst other things, requires new buildings to be energy efficient.

Awareness campaigns putting to the fore what is in it for the individual tenant, owner, developer, architect, and engineer will help to establish energy efficiency standards in the building sector. In this regard, the GBCN could play an active role.

## 10.7 Access to Finance

Building projects are capital intensive, and capital costs are high in Nigeria. Access to affordable financing instruments is paramount for a successful establishment of energy efficient buildings.

In this sense, some of the remedial measures to mitigate scarcity of capital are financial collaboration/partnerships between the government and the private sector (PPP) and applying for some of the multilateral organisations calls for proposals.

Today, an increasing number of international organisations are already active or planning to get involved in supporting the energy efficiency sector in Nigeria. For example, the French Agency for Development (AFD) is planning to establish a credit line for energy efficiency measures providing interest-reduced loans. On the international level, the NAMA-facility provides funding to finance the transition towards sustainable growth in countries. In Mexico, a project with the duration 2013-2019 targets energy efficiency in the residential sector. It is the objective to promote the penetration of basic efficiency standards in the entire new housing market in Mexico by means of: (a) technical assistance to large public housing financiers and small and medium-sized housing developers and; (b) financial incentives and project-related technical support for small and medium-sized developers and financial intermediaries. Another objective is to promote the upgrading of energy efficiency standards to more ambitious levels.<sup>25</sup>

## 10.8 Stakeholder involvement and acceptance – Moving forward together

Establishing energy efficiency in buildings is a joint societal effort and will only be achieved if all relevant stakeholders are involved. Most important stakeholders are:

- Developers, architects, builders, engineers, and their professional associations
- Standards Organization of Nigeria (SON)
- Universities and research organisations
- Consumers associations
- Government ministries
- Construction industry
- Building products industry

<sup>25</sup> [http://www.nama-facility.org/uploads/media/NAMA\\_Facility\\_factsheet\\_Mexico.pdf](http://www.nama-facility.org/uploads/media/NAMA_Facility_factsheet_Mexico.pdf)

The Federal Ministry of Power, Works and Housing (Housing) (FMPWH) has established an inter-ministerial committee to ensure the smooth transition towards an energy efficient building sector. The committee will be leveraged upon to share and promote knowledge on energy efficiency in buildings. The committee is composed of stakeholders from both the energy and housing sector and hence this ensures synergies across relevant sectors critical for the promotion of energy efficiency in buildings.

## 10.9 International Experience – Network and Benefit

Nigerian research institutions, professional associations and public bodies benefit from international co-operation. It provides access to up-to-date knowledge which can be adapted and further developed to be useful in Nigeria. From the other perspective, Nigeria is an important partner due to its role as the economic powerhouse in West Africa.

To participate in international co-operation, it is important to have clear assignments and budgets to take the right steps to initiate and then maintain co-operation successfully.

Potential platforms for co-operation are for example:

- American Society of Heating, Refrigerating and Air-Conditioning Engineers<sup>26</sup>
- International Council of Air-Conditioning, Refrigeration, and Heating Manufacturers Associations (ICARHMA)<sup>27</sup>
- International Energy Agency<sup>28</sup>
- Climate Alliance<sup>29</sup>

The European Union collaborates with many countries outside Europe, and non-EU countries also have access to the research and technology development programmes<sup>30</sup>.

The recent development of energy efficiency regulations in South Africa may also provide a useful case study for Nigeria. At the turn of the century, South Africa was in a similar position to Nigeria with no clear building regulations on energy efficiency. A voluntary standard SANS 204 “Energy Efficiency in Buildings” was developed in 2008 which gives guidance on construction U values, equipment efficiency, and gave targets in terms of kWh/m<sup>2</sup>/year. While setting simple performance targets in kWh/m<sup>2</sup>/year is attractive to legislators, in reality it is very difficult to enforce such targets since the responsibility for excessive energy use can be blamed on many factors such as the original design, the construction quality, inefficient equipment installed by the tenant, inefficient operation and maintenance, etc.

A few years later, after some development of the standard, some aspects of the standard were incorporated into a new mandatory building regulation SANS 10400-XA. This offers two main ways of compliance, the first being an elemental approach where the building U values for walls and roofs must achieve stated values, together with limits on glazing areas and performance. The alternative compliance route is via energy simulation to demonstrate that the building energy consumption will be less than a similar size building built to the elemental standard. The standard also requires that at least 50% of hot water is heated via a heat pump or a solar water heater.

26. <https://www.ashrae.org>

27. <http://www.icarhma.org/council+members.aspx>

28. <http://iea.org>

29. <http://climatealliance.org/home.0.htm>

30. <http://ec.europa.eu/research/iscp/index.cfm>

# 11 Sustainability Certification

Tool	Strengths	Weaknesses
<b>BREEAM</b>	<ul style="list-style-type: none"> <li>• Independent review by auditor</li> <li>• Based on local standards</li> <li>• Internationally recognised</li> </ul>	<ul style="list-style-type: none"> <li>• Requires licenced certified assessors</li> <li>• High costs for the assessors</li> <li>• High certification fees</li> </ul>
<b>LEED</b>	<ul style="list-style-type: none"> <li>• Independent review by USGBC(GBCI)</li> <li>• Based on local standards</li> <li>• Internationally recognised</li> <li>• Provides training and certification of professionals</li> <li>• High marketability</li> </ul>	<ul style="list-style-type: none"> <li>• High certification fees</li> <li>• Based in internationally recognised standards (i.e. ASHRAE)</li> <li>• Might need interpretation to respond to the local environmental issues</li> <li>• GBCI auditors do not verify on-site implementation of sustainable measures</li> </ul>
<b>Green Star</b>	<ul style="list-style-type: none"> <li>• Recognition and marketability in Africa and Australia</li> <li>• Independent review</li> <li>• Requires assessors training and certification</li> </ul>	<ul style="list-style-type: none"> <li>• Less international recognition than LEED®</li> <li>• Does not cover building operation</li> <li>• Less global marketability than LEED®</li> </ul>
<b>Passivhaus</b>	<ul style="list-style-type: none"> <li>• Recognised system in Europe</li> <li>• Simple assessment tools and direct performance approach</li> </ul>	<ul style="list-style-type: none"> <li>• Mainly used in cold climates, recently adapted to hot climates</li> <li>• Less market value</li> </ul>
<b>EDGE</b>	<ul style="list-style-type: none"> <li>• Intended for developing countries</li> <li>• Provides help assessing capital costs and longer term savings</li> </ul>	<ul style="list-style-type: none"> <li>• Does not provide detailed design advice</li> </ul>
<b>GBCN</b>	<ul style="list-style-type: none"> <li>• Locally developed and designed to suit Nigeria conditions</li> <li>• Includes social and economic measures</li> <li>• Local capacity building and education opportunities via the GBCN</li> </ul>	<ul style="list-style-type: none"> <li>• Still in development</li> <li>• Scope limited to residential buildings</li> <li>• Not known outside of Nigeria</li> </ul>

## 11.1 Chapter Summary

Certification schemes aim to assess buildings in a quantitative and unbiased way, producing a simple score or rating. This can be used either to demonstrate the building's environmental credentials, or a client can specify a desired rating as part of their brief to ensure that they obtain a building with sustainable features.

The previous table summarises the best known international systems and the systems under development by the GBCN.

### Key Findings

It is hoped that the residential tools being introduced by the GBCN will gain traction and become popular in the residential market.

For other projects, until a local rating is available, Green Star and LEED would seem best suited for building certification in Nigeria, although the challenges of using international rating schemes should not be underestimated.

## 11.2 Introduction

With the growing interest in energy efficient buildings, the need to understand the metrics for sustainable buildings, and to distinguish between truly "green" buildings and those that are conventional buildings made to look green for example by incorporating some PV systems, referred to as "green wash", has arisen.

This section provides an overview of the best known internationally recognised green building certification tools, and ends with a description of the tools currently in preparation by the GBCN.

As well as demonstrating corporate responsibility and assisting with marketing, the certification schemes offer benefits such as making design teams more familiar with sustainability concepts, and also help to ensure that the green measures are carried through to completion of the building, rather than being gradually omitted due to cost cutting or procurement difficulties.

All these rating systems require significant amounts of paperwork to demonstrate compliance with the individual credits, and most require detailed energy simulations to be carried out, and this must be taken on board when deciding whether or not to specify a rating. It is also advantageous to decide on the rating system at the early concept design stage, since otherwise the team may find that some credits are unattainable.

## 11.3 Green Building Council of Nigeria (GBCN)

The GBCN is planning to operate a building evaluation system developed in Nigeria and targets residential buildings such as bungalows and apartment buildings. It has based its principles on the experience gained worldwide with existing green building assessment schemes, adapting and complementing them with essential technical, social and economic criteria to be considered for a successful implementation in Nigeria.

The goal is to generate a profile of a building's strengths and weaknesses from a detailed analysis during the design or planning stage, in order to improve the building's quality and reduce pollution over its entire life cycle. As the life cycle of buildings is extremely long compared to that of most other products, the consequences of any decisions made will be felt for a long time.

GBCN suggests a number of criteria to optimise the planning, construction and utilisation of buildings. Everyone involved stands to benefit: comprehensive planning assistance and execution monitoring play an important role for the team of planners and the local building supervisors. The future tenants or buyers receive the key data of their apartment in the form of a building pass and can therefore quickly get information about the building quality and maintainability performance, especially with regard to aspects relevant to the users. At the same time optimum climate protection, resource efficiency and eco-friendliness when erecting the building play an important role.

The sustainable building certificates are ideally suited for public relations and product marketing purposes to present outstanding project characteristics<sup>31</sup>.

<sup>31</sup>. More information can be found at [gbcn@yahoo.com](mailto:gbcn@yahoo.com)

## 11.4 Sustainable Buildings Certification Systems

### BREEAM

The Building Research Establishment's (BRE) Environmental Assessment Method was the first rating tool, and was launched in the UK in 1990. It is continuously updated, and sets the standard for best practice in sustainable building design and construction. Its main goals are focused on the mitigation of the life cycle impacts of buildings on the environment, enabling buildings to be recognised according to their environmental benefits and to attain credibility. In Nigeria, a bespoke BREEAM rating can be obtained, where a BREEAM assessor first has to propose minor modifications to the system to suit Nigeria, which are then approved by the BRE. This makes the process rather expensive and lengthy.

### LEED

Leadership in Energy & Environmental Design, LEED®, is the sustainability rating system created by the US Green Building Council (USGBC). It is based on a set of performance based criteria with a wide range of paths to achieve the level of certification. LEED projects are evaluated per criterion which is either a 'Prerequisite' or 'Credit' which results in a point score for certification. LEED can be carried out internationally, and the submissions are now web-based. However, credits are based around typical American construction and equipment performances, which can make compliance difficult in developing countries.

### Green Star

Green Star was launched in 2003 by the Green Building Council of Australia (GBCA) and is broadly similar in approach to BREEAM and LEED. It looks at a building's management, internal environment, energy consumption, water consumption, material selection and ecology degradation, with two certification stages available "Design" rating at tender stage, and an "As Build" rating upon completion. Green Star has been adapted by the Green Building Council of South Africa (GBCSA) for use in South Africa, and this can be used in other African countries subject to some adaptations.

### Passivhaus

The Passivhaus standard is for residential buildings, and while originally developed for cold European climates, it could be adapted to also cover warm climates. The system uses excel based tools for conducting the assessment.

### EDGE

The EDGE tool has been developed by the International Finance Corporation (IFC) in partnership with the World Green Building Council, and is aimed at identifying low-cost sustainable opportunities for buildings particularly in developing countries.

A building achieves the EDGE standard when 20% efficiency is met in energy, water, and embodied energy in materials.

Less complex than tools such as LEED, the EDGE rating aims to capture the capital costs and projected operational savings for various measures at the early conceptual stage.

It is intended for use by building professionals rather than green building specialists, and uses an excel platform.

# 12

## Case Studies: Energy Analysis of Buildings in Nigeria

### 12.1 Chapter Summary

Four case studies are presented; a 3 bedroom bungalow, an apartment, a small office and a large office. In each case, a business as usual (BAU) case is proposed and modelled, followed by three variants which gradually increase the energy efficiency of the building. For each variant, the costs for the measures are estimated together with the resulting reduction in energy consumption and running costs.

#### Key Findings

##### Bungalow/Apartment

- Since there is no cooling, the largest energy saving is achieved by replacing conventional lighting with high energy efficiency lighting.
- Roof insulation, cavity walls, well-orientated windows and external shading make the internal conditions significantly more comfortable.
- While energy used to heat water (for bathing/washing) does not represent a very large percentage of total energy use at the moment, it is likely to increase as living standards improve and solar hot water heating should be recommended.
- Appliance labelling would help people to choose energy efficient appliances.

##### Offices

- Passive measures (reduced glazing, external shading, better orientation, roof and wall insulation etc.) have a large impact on energy consumption by reducing the cooling loads.
- More efficient VAC systems and controls can also make a significant contribution.
- Reductions are broadly similar in the two climate zones.
- Renewable energy produced by PV systems are ideal for offices due to the match between the generating and consumption profiles. However, this strategy requires large areas occupied by PV panels in order to meet the entire building's demand with this renewable energy.

### 12.2 Introduction

One of the objectives of this guideline is to assess and quantify the impact of specific energy efficiency measures and to improve on future building energy efficiency standards. This section presents four case studies, and aims to highlight the most effective measures to improve energy performance in Nigeria. The building typologies analysed are residential (bungalow and apartment) and office building (large and small). Both typologies have been tested for the hot & dry climate and the hot & humid climate.



## 12.3 Variants definition

In order to illustrate the impact of energy efficiency measures on each building type, a BAU case was defined for each typology. The BAU aims to be representative of the norm in current building design practices and installed equipment (e.g. for VAC or lighting) in Nigeria. The BAU was derived from responses to questionnaires circulated in various parts of Nigeria in April-June 2015, together with local knowledge. Then three variants on this BAU were modelled where incremental improvements have been made following the principles of the energy hierarchy.

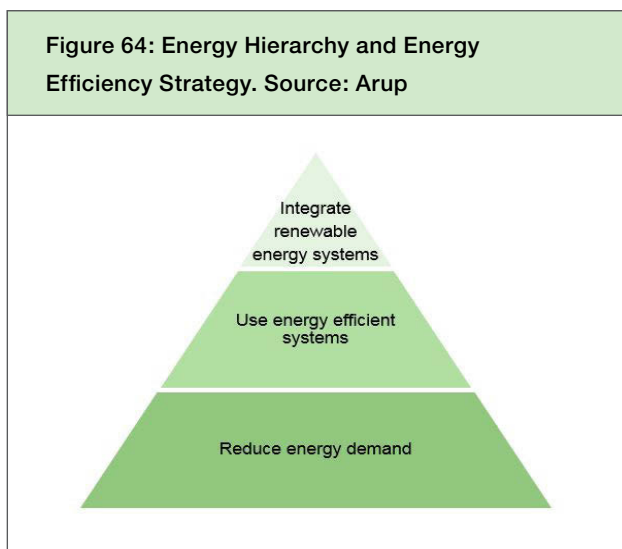

The defined variants for this study are:

- Variant 1: reducing energy demand by simple measures such as improving orientation, optimising window sizes, adding roof insulation and affordable improvements such as higher efficiency lighting.
- Variant 2: as Variant 1 but with additional measures such as insulated walls, double glazing, solar hot water heating and similar.
- Variant 3: as Variant 2 but adding PV to generate renewable electricity.

It should be noted that these measures are sample measures only and may not be appropriate for all projects. For each individual project designers should assess the most appropriate measures for that particular project. Similarly, the estimates of energy and cost savings are for guidance only and will depend on the individual project circumstances. They should not be regarded as a guarantee of savings for a real project.

## 12.4 Source of building data

The typical building layouts for residential and office buildings have been provided by the FMPWH and Design Genre. Based on this information, simplified models representing the typical building configurations have been developed.

## 12.5 Source of cost data and procedure of economic assessment

Building related costs have been provided by Billing Cost Associates, a professional Quantity Surveyor in Lagos based on previous project experience. The cost represents just construction cost and do not include the land cost.

The annual cost of energy has been calculated using the energy billing rate and the cost of fuel for the energy fraction provided by backup systems:

- The cost of electricity from the grid and diesel used to run generators was calculated assuming that the cost of electricity for domestic and non-domestic use was ₦13.21 per kWh and ₦26.44 per kWh respectively<sup>32</sup>.
- Diesel was assumed to cost ₦160 per litre and petrol ₦87 per litre<sup>33</sup>.

## 12.6 Simulation tool

The simulation tool selected for this analysis is DesignBuilder version 3. A whole building dynamic energy simulation tool that uses Energy Plus engine for calculating annual energy consumption of building designs. The software has the capacity of analysing both, passive and active measures such as solar shading compare façade options, simulate natural ventilation and different mechanical systems' options and controls. The main outputs of the tool for this study are annual energy consumption, annual energy cost and hours of thermal comfort.

<sup>32</sup>. Electricity cost data for 2013 from the Power Holding Company of Nigeria (PHCN).

<sup>33</sup>. Diesel cost provided by the Petroleum Products Pricing Regulatory Agency (PPPRA)-July 2015.

## 12.7 Results format

The results of the energy analysis are provided in the following format:

- Energy consumption per net floor area (kWh/m<sup>2</sup>): this metric is a measure of the electricity required to run all systems in the buildings. Reduced energy consumption accounts for the combination of energy demand reduction and the efficiency of active systems.
- Energy production per net floor area (kWh/m<sup>2</sup>): this metric is used to indicate the amount of energy produced by renewable generation on-site. This production will then displace grid and on-site generators.
- Hours of thermal comfort: this metric reflects thermal comfort and is a proxy for reducing the active cooling demand. It is particularly useful in the residential case studies where minimal active cooling is implemented, and performance is measured according to the building capacity for providing improved comfort levels without active cooling. The model provides the number of hours the internal ambient temperature is below a threshold temperature of 28°C. This temperature is deemed as comfortable according to ASHRAE Standard 55 in this climatic zone.
- kg of CO<sub>2</sub> emissions: these were calculated based on the grid carbon intensity for Nigeria from the International Energy Agency (IEA) and the carbon intensity of diesel and petrol generators. It was assumed that residential buildings would use petrol generators whilst offices would use diesel ones. In both cases the electricity from these would represent 40% of the total consumed. This proportion was not changed because even when PV generation was incorporated in the buildings, they were connected to the grid, and no renewable energy storage systems were assumed in the calculations. Therefore, generators would be needed whenever there was grid failure.
- Energy efficiency measures, capital costs (₦) and payback (years): the additional capital cost versus the BAU building and payback periods of suggested measures were estimated.

## 12.8 Case studies analysis

The following sections contain the description of the four case studies and the modelling results for the BAU and variants. Simulations were carried out using DesignBuilder software based on a set of inputs on the building envelope, geometry, materials, cooling systems, appliances

and lighting to produce the results. Hourly weather data from Meteororm for Lagos and Kano was used.

### Bungalow

The bungalow is a typical family home in Nigeria with three bedrooms, a kitchen, a living room, a bathroom and a toilet. The dwelling has a net floor area of 200m<sup>2</sup> and it was assumed to be inhabited by 5 occupants. According to the survey results, bungalows commonly do not have AC systems so these were not introduced. Instead, natural ventilation and fans are used for cooling.

Figure 65: Model of bungalow



### Key Findings – Bungalow Case Study

Since there is no cooling, the energy savings are solely attributed to lighting systems. Savings are achieved by replacing conventional lighting with high energy efficiency lighting. This measure is the same for both climate zones.

Thermal comfort is used as a proxy for cooling demand in buildings with no air conditioning. Hours within the thermal comfort range (using the adaptive comfort approach) improves dramatically with passive measures, especially in the hot & dry climate.

Figure 66: Model of bungalow BAU vs Variants

BAU	VAR 1	VAR 2
<ul style="list-style-type: none"> <li>• Hollow sandcrete wall, <math>U = 1.9\text{W/m}^2\text{K}</math></li> <li>• Pitched metal sheeting roof without insulation</li> <li>• Single glazing with metal frame, <math>U = 5.77\text{W/m}^2\text{K}</math></li> <li>• Badly oriented, majority of windows facing E/W</li> <li>• No external shading</li> <li>• 90% of light bulbs incandescent</li> <li>• Energy inefficient appliances</li> </ul>	<ul style="list-style-type: none"> <li>• Hollow sandcrete wall, <math>U = 1.5\text{W/m}^2\text{K}</math></li> <li>• Naturally ventilated pitched metal sheeting roof with insulation</li> <li>• Improved orientation, majority of windows facing N/S</li> <li>• External shading to windows in the form of 1m horizontal overhang</li> <li>• 100% efficient fluorescent lighting</li> </ul>	<ul style="list-style-type: none"> <li>• Insulated wall, <math>U = 0.7\text{W/m}^2\text{K}</math></li> <li>• Double glazing with metal frame, <math>U = 3.09\text{W/m}^2\text{K}</math></li> <li>• 100% LED lighting</li> <li>• Energy efficient appliances (TV, refrigerator, microwave)</li> <li>• 60% of DHW from solar thermal</li> </ul>

The main improvements in the bungalow have been made in the building geometry and orientation as well as the replacement of incandescent light bulbs with more energy efficient lighting. As can be seen from the diagrams above, the BAU bungalow featured a metal roof which transmitted heat directly to the interior building, and the window design did not include shading, thus transmitting the solar radiation mainly at dawn and dusk because of the building's orientation. This resulted in large heat gains from solar radiation, dramatically reducing the number of thermal comfort hours within the building. It was assumed that cooling is provided by means of natural ventilation and fans, thus having a minimal fraction of the building energy consumption associated to cooling.

The largest electricity consumption was for lighting. As explained in chapter 6 on energy efficient lighting, incandescent bulbs are the most inefficient lighting technology and contribute to internal heat gains.

Since there are no cooling systems, the same results were obtained for both the hot & dry and the hot & humid climate. Cooling electricity is marginal, only for fans, and no difference in electricity consumption was observed.

The most effective improvement in terms of energy consumption was the replacement of incandescent bulbs to fluorescent lighting in Variant 1 and then to LEDs in Variant 2. Figure 67 shows a reduction in lighting energy consumption of more than 80% when installing efficient lightings. We recommend that a requirement within the building codes for new buildings should be the phasing out of incandescent bulbs.

The proportion of electricity for daily hot water is small and the adoption of solar thermal systems is effective in reducing this electrical consumption to negligible amounts (see Variant 2)<sup>34</sup>.

The impact of the bioclimatic design measures was greatest when comparing thermal comfort hours within the building. As discussed in chapter 4, the Adaptive Comfort Standard (ACS) allows a wider range of indoor temperatures to be considered

<sup>34</sup>. Note that the demand for daily hot water in residential buildings is expected to increase in the future as a result in improvements in living standards

**Figure 67: Breakdown of electricity use in simulated bungalow**

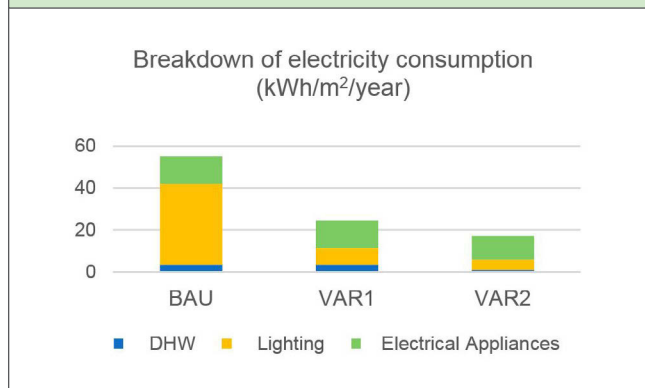

**Table 13: Electricity consumption for lighting & total electricity consumption for bungalows**

Electricity consumption (kWh/m²/year)	BAU	VAR 1	VAR 2
Lighting	38	7	5
Total	55	24	17

**Figure 68: Thermal comfort in bungalow under different climates**

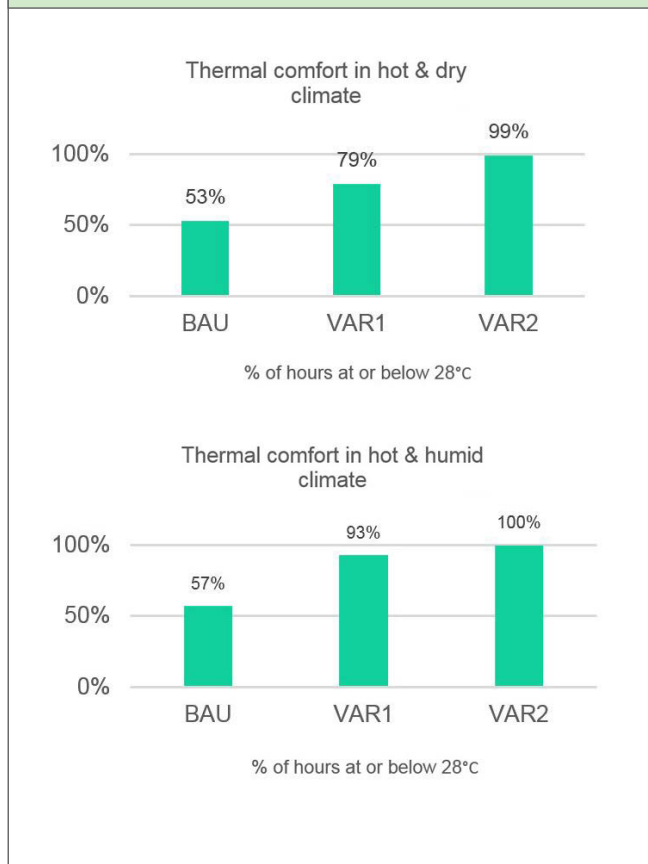

comfortable for naturally ventilated buildings. In line with this, the number of hours that the internal ambient temperature was at or below 28°C was calculated with DesignBuilder and large improvements were observed versus the BAU as shown in Figure 68. Up to 46% improvement was achieved in the hot & dry climate and 43% in the hot & humid.

Under both scenarios, the installation of 50m<sup>2</sup> of solar panels with a capacity equivalent to 7kW facing South on a 30° tilted roof, could meet almost the entire electricity consumption when measures suggested under Variant 2 are implemented (provided sufficient battery storage is available). In the hot & dry climate, the area of solar panels was reduced to 36m<sup>2</sup> because the solar irradiation in Kano is higher than in Lagos and the annual electricity consumption was met with this PV area. Electricity generated by PV panels could also offset electricity consumed by the grid via net metering (i.e. the exported electricity from the PV system counts as offsetting consumption on meters).

Potential carbon savings from the measures suggested range from 50% to 100%, the latter assuming the renewable energy offsets all electricity consumption. Detailed CO<sub>2</sub> emissions calculations indicating emission factors and sources used for this analysis are included in the Appendix A to this document.

The cost of the BAU was estimated to be ₦25 million<sup>35</sup>. The additional capital need is ₦1.45 million to introduce Variant 1 lighting and appliances efficiency as well as comfort improvement measures and ₦3.25 million for Variant 2, which includes wall insulation and improved window glazing. The annual energy costs drop by 56% and 68% respectively under measures in Variant 1 and Variant 2, in accordance with the electricity savings, which are due to lighting and appliances improvements since no cooling has been assumed for the bungalow. The incremental cost of VAR 3 which also includes renewable energy production with PV systems would be ₦5.6 million. Figure 70 below shows the annual cost of energy in each variant. Since the bungalows are not air-conditioned, only lighting and appliances have been considered for the energy consumption calculation.

**Figure 69: Comparison between PV production in Variant 3 and electricity consumption in Variant 2**

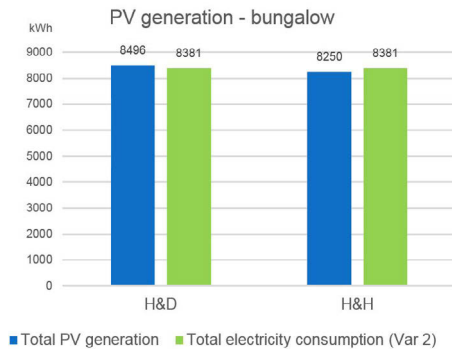

**Figure 70: Annual cost of grid electricity and fuel for generators in bungalow (₦/m²).**

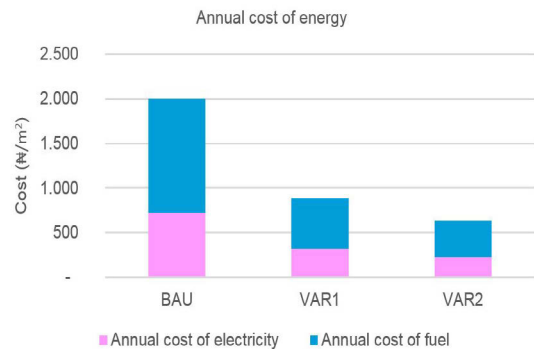

Since the bungalow has no cooling, the energy savings have been produced by the switch to efficient lighting, efficient appliances and the PV installation. The simple payback period for the implementation of the lighting and appliances improvements in Variant 1 and 2 has been estimated at 1 year for the replacement of the low efficient incandescent bulbs to fluorescent or LED lighting and the inclusion of efficient appliances. The payback period for Variant 3, including the PV system for 100% electricity consumption coverage has been calculated at 15 years, due to the fact that batteries have been included in the cost and only lighting and appliances account for energy consumption. The PV option could become a most cost effective option if cooking energy switched to electricity. The main benefit of the PV option is the increased reliability of the electricity supply, since it is less reliant on the grid.

A summary of all the key results is presented below. As shown, the bulk of the energy savings are achieved from Variant 1

improvements. To reduce CO<sub>2</sub> as much as possible PV panels are most suitable. Since no cooling has been assumed for the residential building, the cost included in the payback calculations are those associated with efficient lighting and appliances and the PV system. The following table summarises the cost implications, energy and carbon savings as well as the comfort improvement found in the different variants analysed.

35. For the purposes of this guideline, we have considered the PV panels to be zero carbon as emissions would be negligible in comparison with conventional electricity generation in Nigeria. For a more complete analysis the carbon emissions associated with production, distribution, maintenance and disposal should be considered.

36. Simple payback period. No inflation or interest rates have been included in the calculation. The only cost includes are those related to electricity consumption, lighting, appliances and PV.

**Table 14: Summary of key results for bungalow**

Bungalow	Additional capital cost for lighting and appliances improvement	Energy savings percentage over BAU	Energy cost savings per year (₦/m²)	Annual CO <sub>2</sub> savings per year (kgCO <sub>2</sub> /m²)	Thermal comfort improvement: hours/year (H&D/H&H)	Simple payback <sup>36</sup>
						Lighting/appliance/PV
VAR 1	₦15,600	56%	1,112	27 (52%)	20%/36%	1
VAR 2	₦120,600	69%	1,364	33 (64%)	43%/46%	1
VAR 3	₦5,600,000	100%	1,998	49(100%)	-	15

The complete cost breakdown is included in Appendix A.

### Multi-unit apartment building

The multi-apartment block is a three storey building with 4 apartments on each floor. Each apartment contains two bedrooms, a living room, kitchen, bathroom and one toilet. Each dwelling has a net floor surface of approximately 100m<sup>2</sup> and is occupied by 4 persons. The total net floor area is 1,200m<sup>2</sup>.

Figure 71: Model of multi-unit apartment building

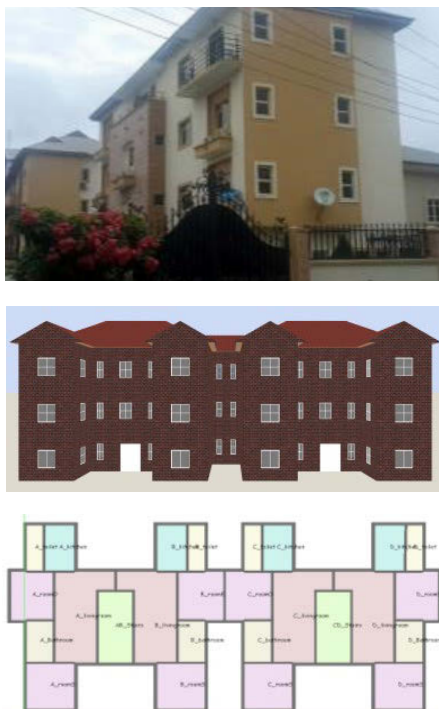

Since no cooling was assumed for the residential use, the results and recommendations were similar to the bungalow. Lighting constituted the largest electrical load and replacement with more efficient lighting was highly effective in reducing energy consumption, see figure and table below. The adoption of more energy efficient appliances also contributed to a reduction in energy consumption, in totality potentially bringing the consumption down by over 60% from near 100kWh/m<sup>2</sup> to 35kWh/m<sup>2</sup> (Variant 2). The annual electricity cost for each variant is provided by the simulation tool Design Builder.

Again, the daily demand for hot water represents a small proportion of the electrical demand, but is expected to increase in the future and therefore should not be ignored. The adoption of solar thermal energy is an effective strategy for reducing this load on the grid system.

Figure 72: Breakdown of electricity consumption in apartment block

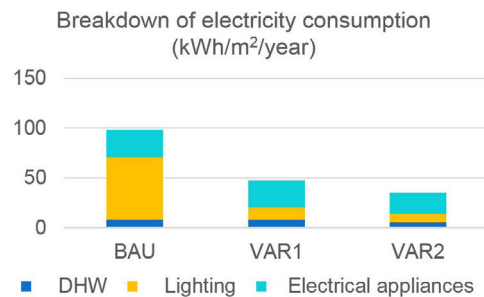

### Key Findings

- Since there is no cooling, the largest energy saving measures are achieved by replacing conventional lighting with high energy efficiency lighting which is the same for both climate zones.
- A significant reduction in electricity for appliances is observed in Variant 2 when more efficient systems are introduced.
- Domestic hot water (DHW) reduces in Variant 2 because a third of the thermal energy is generated from solar hot water system, displacing the need for the grid.
- Hours within the thermal comfort range (using the adaptive comfort approach) improves dramatically with passive measures, especially in the hot & dry climate.

Table 15: Electricity consumption for lighting & total electricity consumption for apartment block

Electricity consumption (kWh/m <sup>2</sup> /year)	BAU	VAR 1	VAR 2
Lighting	63	13	8
Total	98	48	35

Figure 73: Model of multi-unit apartment BAU vs Variants

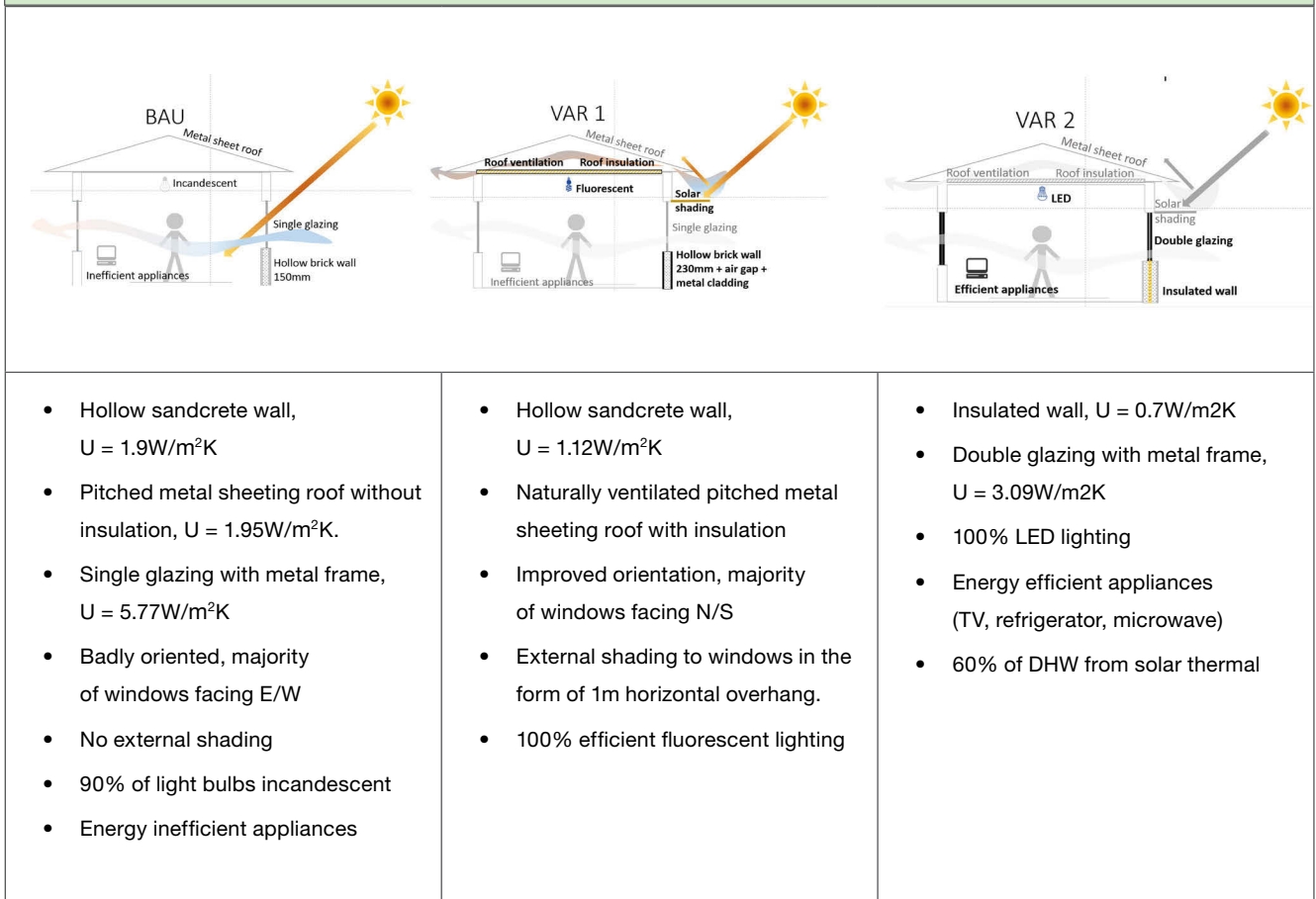

The lack of cooling means that the building consumes an equivalent amount of electricity in both climates as both have the same demand for lighting and other appliances. The multi-apartment block, however, performs better in terms of thermal comfort in the hot & humid climate. This is attributed to the less variable and less extreme high temperatures characteristic of the climate. Therefore, natural ventilation and fans function most effectively.

It was assumed that 125m<sup>2</sup> were covered with south facing PV panels at a 30° tilt. This is equivalent to a peak capacity of 17.5kW. The displacement of grid and on-site generators is 72% and 50% in Kano (hot & dry climate) and Lagos (hot & humid climate) respectively for the multi-apartment block. The reduced contribution of renewable energy in relation to the bungalow is caused by the decrease in ratio of roof area to internal surface area.

Again, the Variant 1 achieves a large saving in carbon emissions, a reduction of over 50% whilst investment in solar panels for the rooftop results in 90% and 82% carbon savings under the hot & dry and hot & humid climates respectively.

Figure 74: Thermal comfort in apartment block under different climates

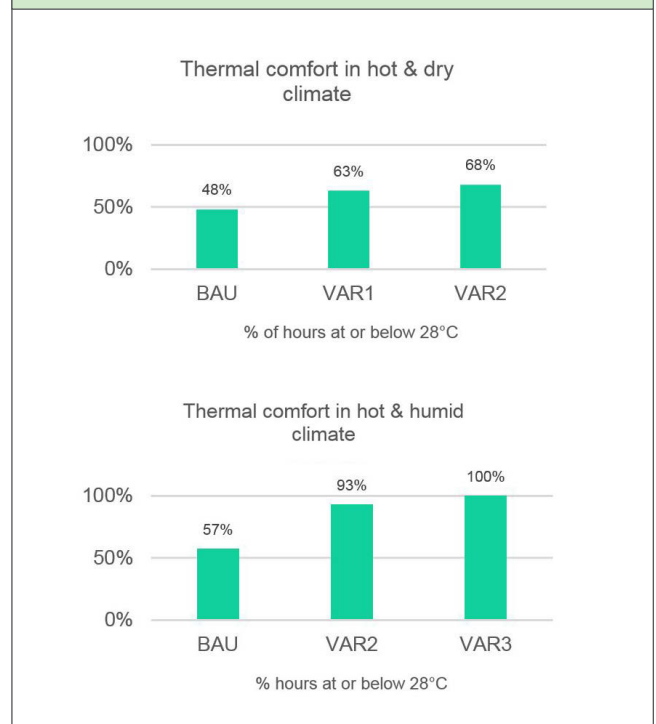

**Figure 75: Comparison between annual PV production in Variant 3 and annual electricity consumption in Variant 2**

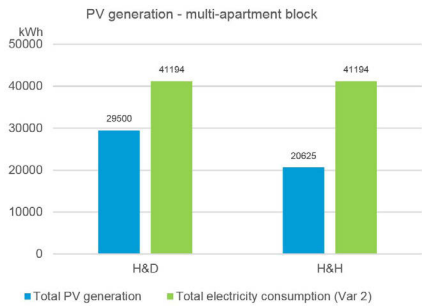

**Figure 76: Annual cost of electricity in apartment block (₦/m²)**

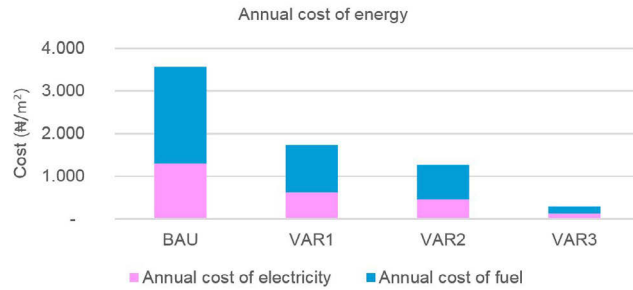

The cost of the BAU for the entire apartment block was estimated to be ₦174 million not including the cost of land. The annual cost of used energy decreases in line with the reduced consumption by 40% and 60% by implementing the measures in Variant 1 and 2 respectively.

A summary of all the key results can be found below. As shown, the bulk of the energy savings and comfort improvement are

achieved from Variant 1 improvements, but only up to just over 50%. Beyond that, LEDs could enable the multi-apartment block to reduce consumption by 64% and operate at 35kWh/m². At this point, installation of PV panels is effective in reducing CO<sub>2</sub> emissions considerably and could possibly displace the need for a generator if the storage is sized and operated appropriately. Since no cooling has been assumed for the residential building, the cost included in the payback calculations are those associated to efficient lighting and

<sup>37</sup> Simple payback period. No inflation or interest rates have been included in the calculation. The only cost included are those related to electricity consumption, lighting, appliances and PV.

**Table 16: Summary of key results for apartment building**

Apartment block	Additional capital cost for lighting and appliances improvement	Energy savings percentage over BAU	Energy cost savings per year (₦/m²)	Annual CO <sub>2</sub> savings per year (kgCO <sub>2</sub> /m²)	Simple payback period <sup>37</sup> Lighting appliances/PV
<b>VAR 1</b>	₦171,600	52%	1,842	45	1
<b>VAR 2</b>	₦1,719,600	64%	2,299	56	1
<b>VAR 3</b>	₦12,280,400	90% of electricity demand	3,272	78	4

The cost breakdown is included in Appendix A.



### Office building: small office

A typical small office has been modelled as three storey building, net area 800m<sup>2</sup> with an open plan office, toilets and meeting rooms on each floor. The average occupancy rate is 12.5m<sup>2</sup> per person with 50% of the façades glazed in all orientations.

#### Key Findings

Passive measures and higher VAC system efficiency have the largest contribution in overall energy reduction since they affect cooling which is the main electric load. There is a slightly bigger reduction in hot & humid climates given the higher number of annual hours where air conditioning is required.

PV integration in the roof is a well suited technology to offset non-renewable energy consumption in this building typology.

Figure 77: Model of small office buildings

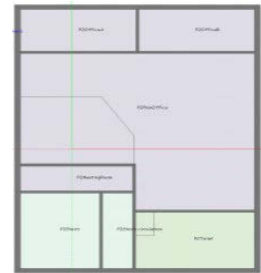
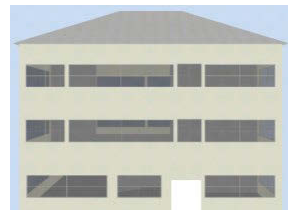

The components of electricity consumption are very different for offices and residential buildings. As can be seen in the Figures 78 and Figure 79 the majority of electricity is used to power the cooling systems. Electricity consumption was reduced significantly by a combination of passive strategies and improvement in active systems. As such, in terms of improving the building envelope the focus should be on reducing the cooling demand via restrictions on apertures, enhanced shading and improvement in window design (i.e. double glazing and use of reflective glass requirements).

Codes informing window design are particularly important for offices because of the tendency to have large areas of glazing in comparison to residential buildings. In terms of improving the performance of active cooling systems, as a minimum, building managers should adjust the set point temperature to a minimum of 24°C, a temperature that is comfortable for occupants and offsets the inevitable internal gains from office equipment.

The adoption of more efficient lighting shows a significant impact, while the improvement of office equipment is relatively marginal but it should be encouraged since efficient equipment releases less heat and reduces internal gains thus reducing the cooling demand.

Overall energy demand is reduced by between 32-36% and 58-59% under Variant 1 and 2.

Figure 78: Breakdown of electricity use in small office in hot & dry climate

Breakdown of electricity consumption in hot & dry climate (kWh/m<sup>2</sup>/year)

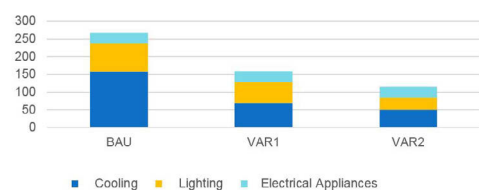

Figure 79: Breakdown of electricity use in small office in hot & humid climate

Breakdown of electricity consumption in hot & humid climate (kWh/m<sup>2</sup>/year)

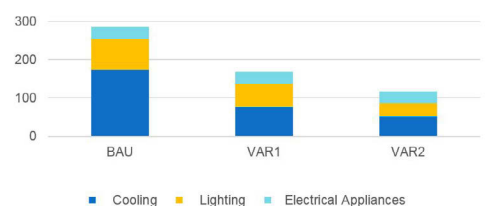
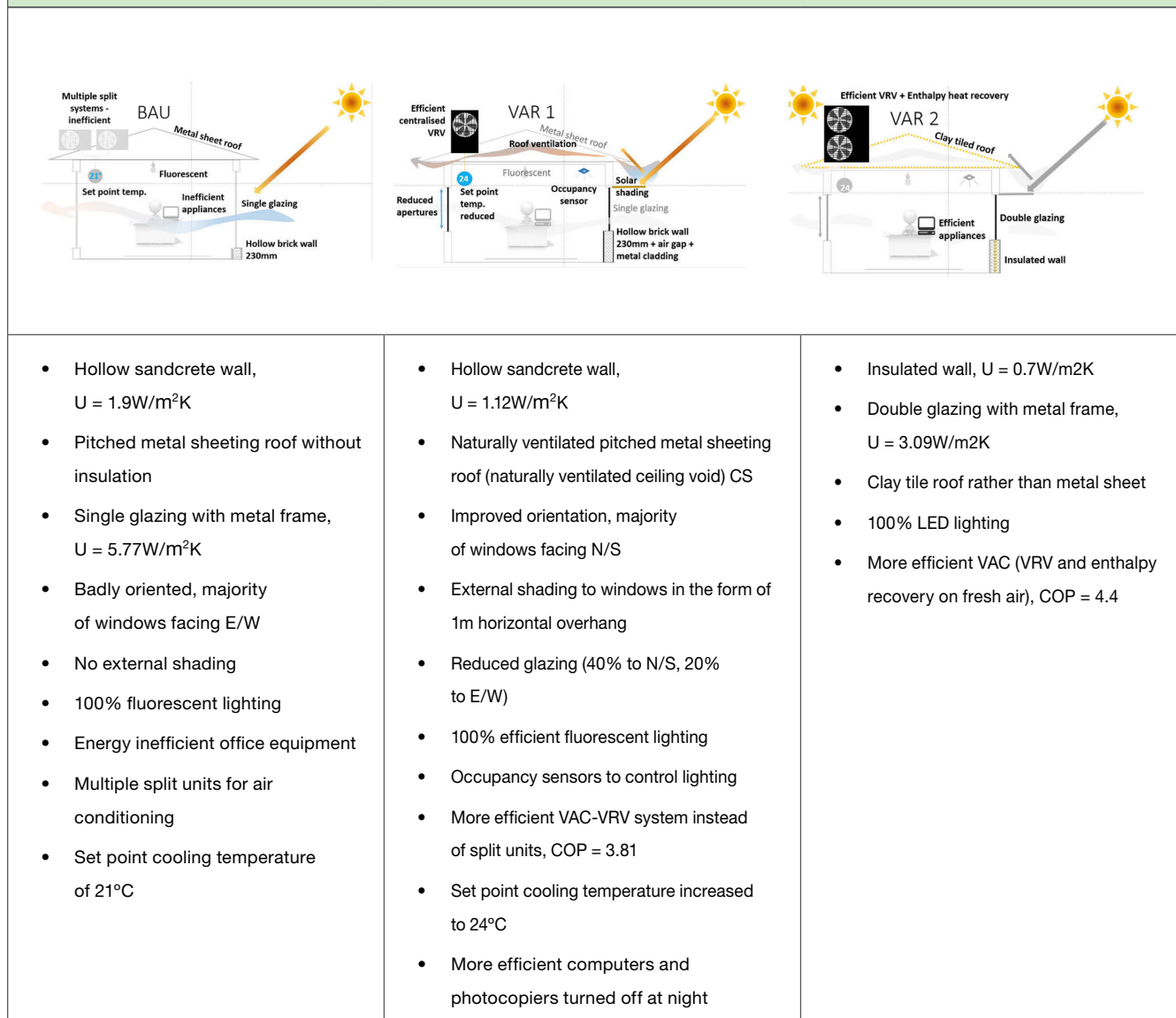

Figure 80: Model of small office BAU vs Variants



Integrating solar PV reduces reliance on grid but its contribution in this typology is smaller than for residential because of much greater load and space constraints. According to our results, solar PV could meet up to 39% of electricity demand from the grid in the hot & dry climate and 27% in the hot & humid climate with 21kW installed on the roof. Nonetheless, PV panels are a renewable energy technology well suited to office blocks, as consumption is predominantly during the day.

Carbon savings are in the order of 40% as a result of energy efficiency measures in Variant 1 and increase near 60% and around 70% with the inclusion of PV panels.

The cost of the BAU was estimated to be near ₦148 million. Additional capital costs for bio-climatic design measures and active systems total ₦6 million for Variant 1 and ₦13 million for variant 2 (including variable 1 measures). Total cost for Variant

3, which includes 1 and 2 measures has been estimated at ₦30 million. Based on actual electricity and generators fuel, the annual energy costs would drop from over ₦10,000 per m<sup>2</sup> per year to less than ₦6,000 per m<sup>2</sup>. This drops further to ₦4,000 and ₦2,000 per m<sup>2</sup> if measures from Variant 2 and the rooftop PV panels are adopted respectively.

A summary of the key results can be found below. In this case, energy savings were approximately 40% from the Variant 1 package of measures. A further 20% versus BAU were achieved by the adoption of a more efficient VRV (COP 4.4) and optimising bio-climatic design.

The payback period for the measures proposed do not exceed 5 years in all cases. Since cooling is included in the office scenarios, the total costs have been included in the calculations.

**Figure 81: Comparison between annual PV production in Variant 3 and annual electricity consumption in Variant 2**

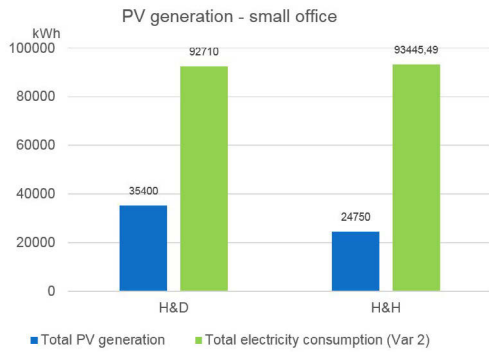

**Figure 82: Annual cost of energy (₦/m²) in hot & dry climate**

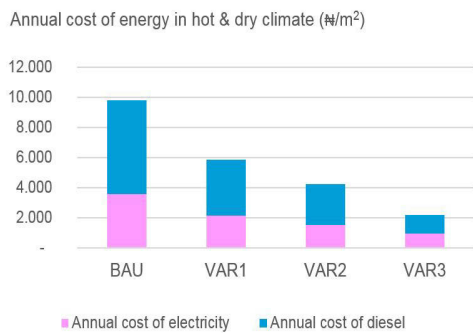

**Figure 83: Annual cost of energy (₦/m²) in hot & humid climate**

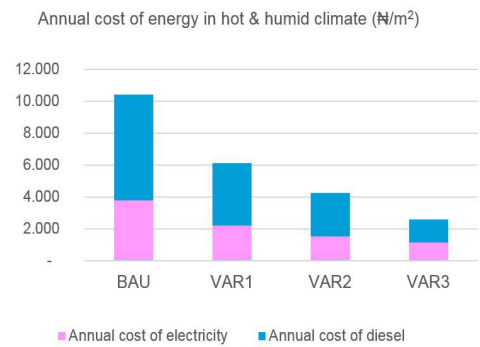

**Table 17: Summary of key results for small office**

Small Office	Additional capital cost (Naira) & Percentage increase		Energy saving per year (kWh/m²) and reduction percentage over BAU		Energy cost savings per year (Naira/m²)		Annual CO <sub>2</sub> savings per year (kgCO <sub>2</sub> /m²)		Simple payback
	BAU COST: ₦148,000,000		H&D	H&H	H&D	H&H	H&D	H&H	
Climate	N/A		H&D	H&H	H&D	H&H	H&D	H&H	H&D/H&H
<b>VAR 1</b>	₦6,012,240	4%	108 (40%)	117 (41%)	3,946	4,277	60	65	2
<b>VAR 2</b>	₦13,270,305	9%	154 (57%)	169 (59%)	5,593	6,163	85	93	3
<b>VAR 3</b>	₦30,070,305	20%	198 (73%)	200 (70%)	7,625	7,795	109	110	5

A complete cost breakdown is included in Appendix A.

### Office building: large office

This typology is represented by a typical large modern office block. A tower with nine floors above-ground, and three levels of underground basement for car parks adding a total 7,400m<sup>2</sup> of net area. The average occupancy rate is 12.5m<sup>2</sup> per person and the envelope features large windows with 85% glazing exposed to all orientations.

**Figure 84: Model of large office buildings**

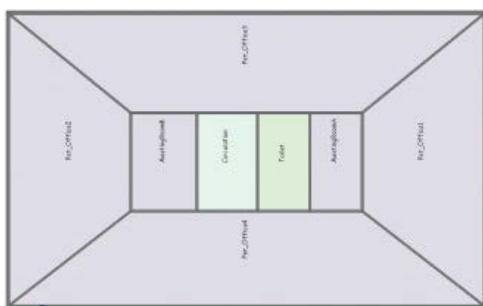
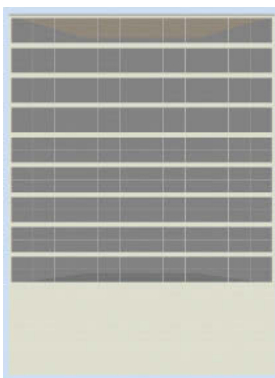

The results show that the largest drop in electricity consumption is in cooling. Similar to the small office, we advocate a re-design of the glazing and adoption of more efficient cooling systems changing from split systems to centralised VRV as a minimum (see Variant 1) and targeting a higher set point temperature. In Variant 2 a chiller was included on the basis that the load in a large office is large enough to justify this investment. Overall energy consumption is reduced by 53-54% and 74-76% under Variant 1 and 2 respectively. The large office exhibits greater energy savings than the small office because the starting point (BAU) had poorer energy performance and more sophisticated energy saving measures were introduced, such as daylight sensors on lighting.

The PV generation can be said to be the least effective in displacing electricity from other sources in the large office because the ratio of roof area to internal floor area will be smallest. Nonetheless, with 70kW capacity or otherwise expressed as 500m<sup>2</sup>, 26% and 18% of the electricity consumption could be met in the hot and dry and hot & humid climate respectively, see graph below. The large office was assumed to have a flat roof and therefore the PV was mounted at an angle of 10°, optimised for the sunpath in Nigeria.

The BAU cost for the large office has been estimated in ₦1,959.9 million.

The additional capital cost for the large office in relation to the BAU is in the order of ₦29 million for Variant 1 measures, ₦65.8 million for Variant 2 and ₦121.8 million for Variant 3.

A summary of the key results can be found below. In this case, energy savings are approximately 50% in the hot & dry climate but only 36% in the hot & humid climate from the Variant 1 package of measures. Under Variant 2, the improvements reach 75% in both climates, suggesting that greater insulation and double glazing is reducing cooling demand.

The payback period in the large office scenario is significantly shorter than in other building typologies because the savings achieved with the improvements are much larger. Especially in lighting and cooling.

### Key Findings

Passive measures and higher VAC systems efficiency have the largest contribution in overall energy reduction since they affect cooling, which is the main electric load.

Figure 85: Model of large office BAU vs Variants

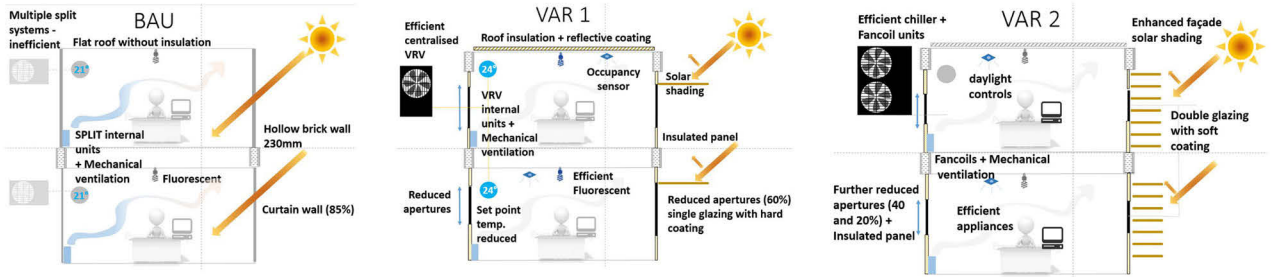

- Curtain wall 85% of glazed area
- Flat roof without insulation
- Badly oriented, majority of windows facing E/W
- No external shading
- 100% fluorescent lighting
- Energy inefficient office equipment
- Multiple split units for air conditioning
- Set point cooling temperature of 21°C

- Reduced glazing 60% in all orientations
- Single glazed 6/6mm air with hard reflective coating
- Other parts of façade insulated opaque panels: glass (6mm) + 40mm insulation panel
- Insulated roof
- Improved orientation, majority of windows facing N/S
- External shading to windows in the form of 1.5m horizontal overhang.
- 100% efficient fluorescent lighting
- Occupancy sensors to control lighting
- More efficient VAV-VRV system instead, COP = 3.81
- Set point cooling temperature increased to 24°C

- Further reduced glazing (40% to N/S and 20% to E/W)
- Double glazed 6/6mm air with soft reflective coating
- Enhanced shading in E/W windows in the form of exterior 0.5m projection louvers
- 100% LED lighting + occupancy sensors to control lighting + daylight sensors
- Clay tile roof rather than metal sheet
- More efficient VAC (Chiller with Fan coils and enthalpy recovery on fresh air), COP = 4.85

Figure 86: Breakdown of electricity use in large office in hot & dry climate

Breakdown of electricity consumption in hot & dry climate (kWh/m<sup>2</sup>/year)

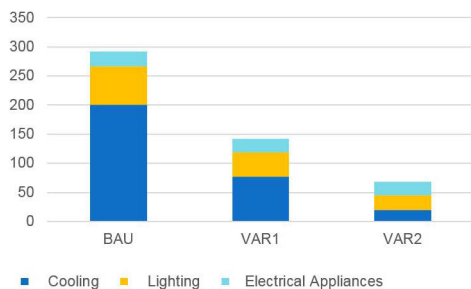
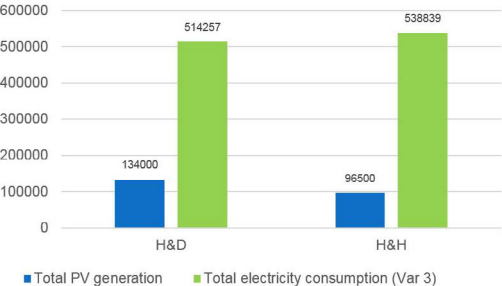
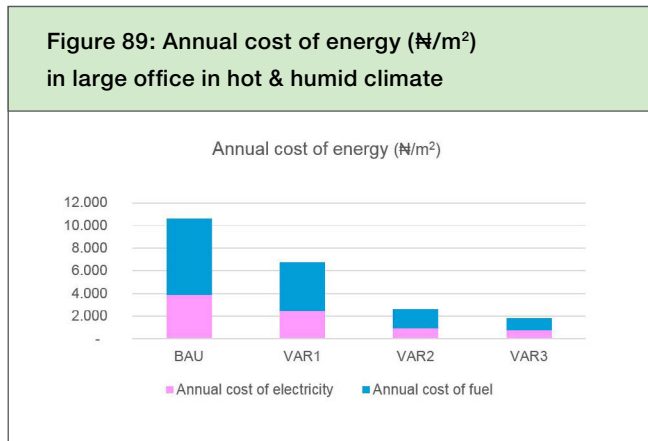
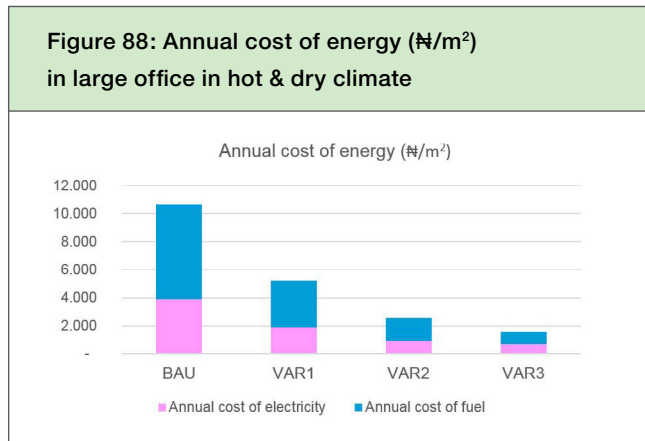

Figure 87: Comparison between annual PV production in Variant 3 and annual electricity consumption in Variant 2

PV generation - large office





**Table 18: Summary of key results in large office building**

Large Office	Additional capital cost (Naira/m <sup>2</sup> ) & % increase		Energy saving per year (kWh/m <sup>2</sup> ) and reduction percentage over BAU		Energy cost savings per year (Naira/m <sup>2</sup> )		Annual CO <sub>2</sub> savings per year (kgCO <sub>2</sub> /m <sup>2</sup> )		Simple payback (years)	
			H&D	H&H	H&D	H&H	H&D	H&H	H&D	H&H
Climate	N/A		H&D	H&H	H&D	H&H	H&D	H&H	H&D	H&H
VAR 1	₦28,789,200	2%	150 (51%)	105 (36%)	5,449	3,819	83	58	1	2
VAR 2	₦65,817,402	3%	223 (76%)	218 (75%)	8,123	7,945	123	120	2	2
VAR 3	₦121,817,402	6%	241 (82%)	231 (79%)	9,089	8,776	133	127	2	2

A complete cost breakdown is included in Appendix A

## 12.9 Conclusions

The results of this analysis show a strong potential for energy consumption reductions and an improvement in thermal comfort conditions in all building typologies analysed and for both climate zones in Nigeria. For all building typologies, basic energy efficiency measures included in Variant 1 accounted for the largest percentage of the total energy reduction potential identified. These measures represent the most economically efficient measures with the shortest payback periods, which are of special interest in large office buildings.

The following table summarises the envelope performance parameters proposed for the Variant 1 scenario, which have been defined by local experts and reflect a realistic improvement in envelope performance for the specific building typologies and typical construction systems used in Nigeria.

Internationally recognised standards such as ASHRAE 90.1 2007, set much more stringent requirements for envelope performance for both the hot and dry and hot & humid climates, defined as 2A and 2B in ASHRAE 90.1 2007. The following table compares the thermal properties of the envelope systems defined in the Variant 1 with the requirements set by ASHRAE 90.1 for the construction systems assessed.

Further studies should be conducted to identify the optimal thermal performance requirements for the building envelope for all building typologies and construction systems in Nigeria in order to set cost optimal requirements in the future building code. This guideline has identified the large potential for energy efficiency and foresees the positive impact that implementing bioclimatic design and improving envelope, lighting and systems performance could have on the energy demand and the environment in Nigeria.

As a summary, figure 90 represents the recommended sequence and hierarchy for the implementation of energy efficiency strategies in the design process.

**Table 19: Typical envelope R and U values for the construction systems analyzed**

Construction System	Typical R value (m <sup>2</sup> K/W)	Typical U value (W/m <sup>2</sup> K)
Metal roof, void, ceiling	0.51	1.95
Metal roof, void, 100mm mineral wool, ceiling	3.22	0.31
Concrete roof with 50mm polystyrene on top	2.69	0.37
150mm hollow sandcrete block wall (rendered)	0.53	1.9
230mm hollow sandcrete block wall (rendered)	0.65	1.6
150mm hollow sandcrete, 25mm polystyrene, 25mm cavity, 100mm brick wall	1.28	0.8

**Table 20: Comparison between Variant 1 thermal envelope thermal performance and ASHRAE 90.1 2007 requirements**

	Variant 1 U (W/°C m <sup>2</sup> )		ASHRAE 90.1 2010 8 (climate zone 2A /2B) U (W/°C m <sup>2</sup> )	
	Residential	Office	Residential	Office
<b>Opaque areas</b>	1.6	1.6	0.701	0.857
<b>Glazed areas</b>	5.7	5.7	4.26	4.26
<b>Roof area</b>	0.31	0.37	0.153	0.153

Figure 90: Energy efficiency measures implementation strategy

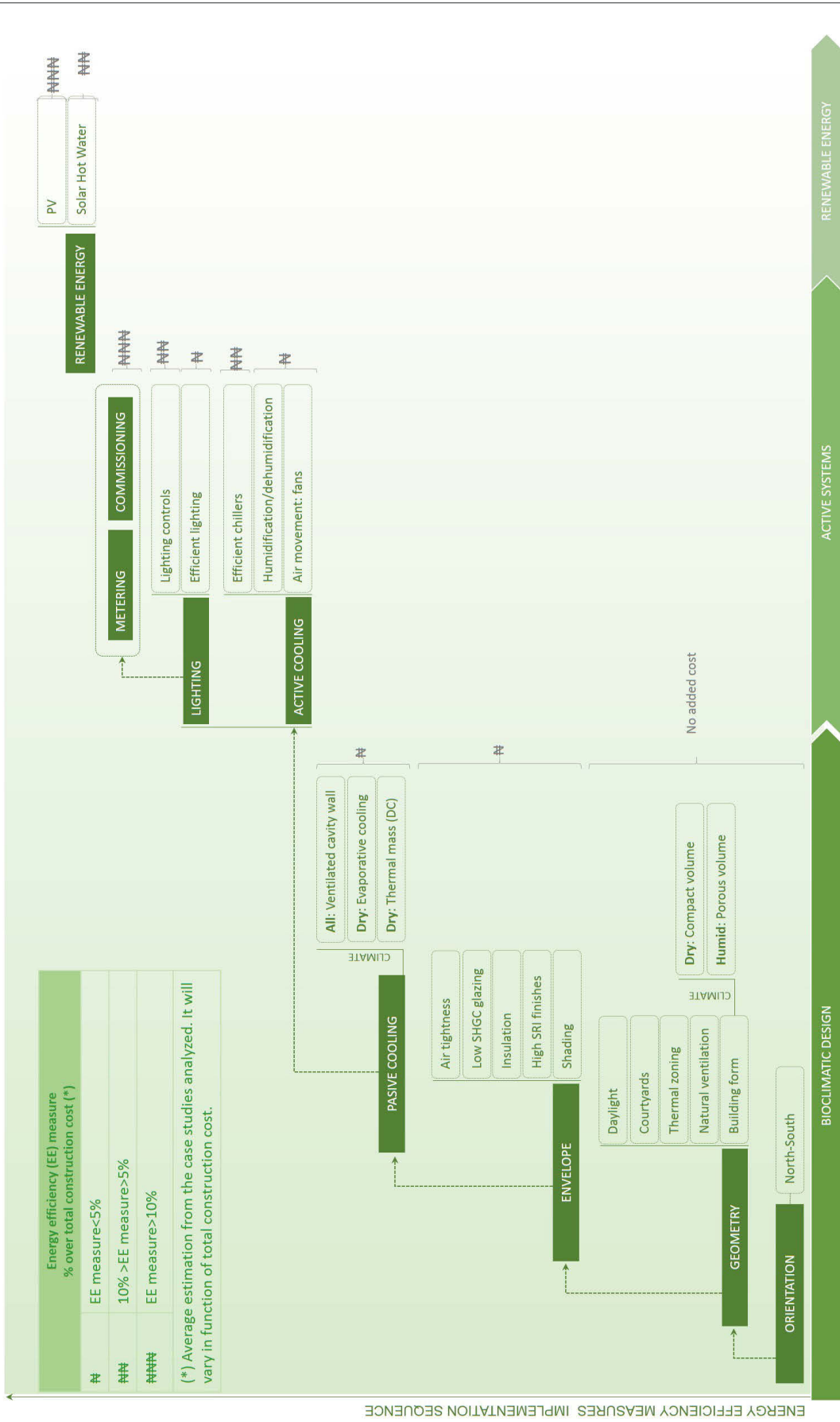



---

# References

**AHSRAE.** (2010). ASHRAE 55.

**Akbari, H. S.** (1992). Cooling our communities, a guidebook on tree planting and white colored surfaces. EPA.

**Arup.** (2014). City Resilience Framework. Rockefeller Foundation.

**Atkinson, F.** (1953). Style and Tropical Architecture - a report of the proceedings of the conference held at University College London.

**Berkley.** (2013). <http://comfort.cbe.berkeley.edu/>. Retrieved from CBE Comfort Tool.

**CIBSE.** (2005). AM10 - Natural ventilation in non-domestic buildings.

**CIBSE.** (2005). Lighting Guide LG7: Office Lighting.

**ECOWAS.** (2013). Directive on Energy Efficiency in Buildings.

**Encraft.** (2009). Warwick Wind Trial Project - Findings Report.

**Energy Commission of Nigeria.** (2014). National Energy Masterplan.

**Federal Government of Nigeria.** (2015). Energy Efficiency Policy.

**Federal Government of Nigeria.** (2015). National Energy Action Plan.

**Federal Government of Nigeria.** (2015). Renewable Energy Policy.

**FMECCD, F. M.** (2011). National Adaptation Strategy and Plan of Action on Climate Change for Nigeria.

**G.S. Brager, R. d.** (2001). Climate, Comfort & Natural Ventilation: A new adaptive comfort standard for ASHRAE Standard 55. Berkeley: University of California, Berkeley.

**G.Z. Brown, M. D.** (2001). Sun, Wind & Light: Architectural Design Strategies. New York: John Wiley & Sons, Inc.

- GBCSA.** (2012). GBCSA Energy and Water Benchmark Methodology - Final Report.
- GBCSA/Arup.** (2009). Existing Buildings Survival Strategies.
- GIZ.** (2014). TOR BEEG Nigeria.
- Huft, A.** (2001). Classification des climats de Köppen » dans Introduction à la climatologie: Le rayonnement et la température, l'atmosphère, l'eau, le climat et l'activité humaine, page 12. Laval: Presses Université Laval.
- IPCC, I. P.** (2013). Working Group I Report "Climate Change 2013: The Physical science Basis".
- J. Fergus, N. a.** (n.d.). Adaptive Thermal comfort and sustainable Thermal Standards for Buildings.
- J.F.Nicol, M. H.** (2002). Adaptive thermal comfort and sustainable thermal standards for buildings. Energy and Buildings, 563-572, Volume 34, issue 6.
- Kato, S. &.** (2007). Estimation of storage heat flux in an urban area using ASTER data. . Remote Sensing of Environment, 110(1), 1-17.
- Meier, A., & Thomas Olofsson, R. I.** (2002). What is an Energy Efficient Building? IX Encontro Nacional de Tecnologia do Ambiente Construido. Paraná: ENTAC.
- National Government of Nigeria.** (2006). Nigeria Federal Building Code.
- Nations, U.** (1987). Report of the World Commission on Environment & Development: Our Common Future.
- Nebo, C.** (2014). <http://sunnewsonline.com/new/55-electricity-consumers-not-metered-says-nebo/>. Retrieved from <http://sunnewsonline.com>.
- NESP.** (2013). Energy Efficiency in Buildings (EEB) in Selected Sub Sectors of the Nigerian Building Sector: Development of recommendations for interventions to promote energy efficiency in buildings.
- NESP.** (2014). The Nigerian Energy Sector 2014. Nigerian Energy Support Program.
- Nigeria, E. C.** (2014). National Energy Masterplan.
- NRRE.** (2015). <http://www.energyplatformnigeria.com>. Retrieved from [http://www.energyplatformnigeria.com/images/Library/NREEE\\_Policy\\_2015\\_FEC%20approved\\_-\\_FGN.pdf](http://www.energyplatformnigeria.com/images/Library/NREEE_Policy_2015_FEC%20approved_-_FGN.pdf).
- O. Ola Ogunstone, B. P.-O.** (2002). Defining Climatic Zones for Architectural Design in Nigeria: A Systematic Delineation. Journal of Environmental Technology, 1-14.
- O.M. Eludoyin, I. A.** (2013). Air, temperature, relative humidity, climate regionalization and thermal comfort of Nigeria. International Journal of Climatology.

---

**O.P., A.** (2011). Importance of climate to architectural designs in Nigeria. *Journal of Environmental Issues and Agriculture in Developing Countries*, volume 3 Number 1, 15-28.

**Olgay, V.** (1963). *Design with Climate: Bioclimatic Approach to Architectural Regionalism*. Princeton.

**Perkins+Will, B.** (2001). *The Integrated Design process: Report on a National Workshop*. Toronto.

**PITTA, S., & GOULART, T.** (1994). *Advanced topics in Bioclimatology to building design*,. PPGEC-UFSC (PPGEC-UFSC).

**Sambo, A. S. (2010).** *Electricity Generation and the Present Challenges in the Nigerian Power Sector*. Energy Commission of Nigeria, Abuja-Nigeria.

**Santamouris, M.** (2001). Heat Island Effect. In M. Santamouris, *Energy and climate in the urban built environment* (pp. 48-69). London: James & James ( Science Publishers) Ltd.

**Uduku, O.** (2006). Modernist architecture and 'the tropical'in West Africa: The tropical architecture movement in West Africa, 1948–1970 *Habitat international* 30 (3), 396-411.

**UN Habitat, a. A.** (2004). *Interlocking Stabilised Soil Blocks - Appropriate Aarth Technologies in Uganda*.

**Urbanism, A.** (n.d.). /traditional-igbo-design. Retrieved from africanurbanism: <http://africanurbanism.net/2012/03/31/traditional-igbo-design/>

**US Green Building Council.** (2015). *Green Building Facts*.

**World Green Building Council.** (2013). *The Business Case for Green Building*. World Green Building Council.

**World\_Bank.** (2014). *Catalog Sources: World Development Indicators*. <http://data.worldbank.org/indicator/EG.USE.ELEC.KH.PC/countries?display=default>.

**ZAS Architects+Halsall Associates.** (2008). *Green Schools, Resource Guide*.

**Zimmerman, A.** (2003). *Integrated Design Process Guide*. Toronto: Canada Mortgage and housing Corporation.

# Breakdown of measures adopted for each variant simulation and estimated added costs

The cost of each measure has been based on unitary costs or complete systems cost provided by Billing Cost Associates for the BAU and energy efficiency measures proposed. Quantities

have been estimated based on previous cost consultant experience for similar projects and adapted to the specific buildings representing each case study.

## Bungalow

Bungalow   Variant 1		
Improvement measure	Purpose	Possible alternatives
Improved orientation, majority of windows facing N/S	Reduce solar heat gains	Additional external shading (vertical), trees etc., mitigate solar gains on E&W windows where these cannot be avoided
External shading to windows in the form of 1m overhang	Reduce solar heat gains and direct sunlight into the building	Different shading types e.g. roof overhangs. Planting trees/vegetation
Fluorescent lighting	Reduce lighting energy consumption & internal heat gains	Metal halide and LED lighting
Behavioural change – turning lights off at night	Reduce lighting energy consumption & internal heat gains	Photocell sensors can help automate this. Security lights on PIR rather than being permanently on
100mm rock wool insulation above ceiling and ventilated ceiling void	Reduce heat gain via the roof	Other forms of insulation possible to achieve same level of ceiling insulation  $U = 0.328\text{W/m}^2$ (or better)
Hollow block wall – 230mm sandcrete hollow block, with 13mm rendering	Reduce heat gain via external walls	Other forms of construction to achieve  $U = 1.5\text{W/m}^2$ (or better)

Bungalow   Variant 2		
Improvement measure	Purpose	Possible alternatives
Insulated wall  150mm sandcrete block, 50mm insulation, 10mm Air gap, 100mm brickwork  U = 0.7 W/m <sup>2</sup>	Reduce heat gain via external walls	Other forms of construction to achieve  U = 0.7 W/m <sup>2</sup> K
Double glazed windows	Reduce heat conduction through windows	U = 3.1 W/m <sup>2</sup> K
Clay tile roof rather than metal sheet	Reduce heat conduction through roof	
LED lighting	Reduce energy consumption & internal heat gains	
Solar water heating (300 litre)	Renewable energy generation	
Energy efficient appliances (TV, refrigerator, microwave)	Reduce energy consumption & internal heat gains	

Bungalow   Variant 3		
Improvement measure	Purpose	Possible alternatives
35m <sup>2</sup> (Kano) or 50m <sup>2</sup> (Lagos) of PV, with battery storage and invertors	Generate renewable energy	Wind turbines and other forms of generation

The following tables present the cost breakdown for all the measures associated with construction costs for the bungalow. Costs have been sourced from a professional local quantity surveyor based on project experience. Cost of the PV system has been provided by Arup based on project experience.

Bungalow   Average construction cost		
Unitary cost (Naira/m <sup>2</sup> )	Area	Total cost
125,000	200	25,000,000

Bungalow   Energy efficiency measures cost breakdown						
Scenario	Measure description	Added cost Naira/unit <sup>39</sup>	Unit	Quantity	Total added cost Naira	% Increase over BAU
<b>Variant 1</b>	Added external shading to windows in the form of 1m overhang	7,560.00	m	18.00	136,080.00	6%
	Change from incandescent to fluorescent lighting	1,300.00	unit	12.00	15,600.00	
	Added 100mm rock wool insulation above ceiling	6,200.00	m <sup>2</sup>	200.00	1,240,000.00	
	Added ventilation to roof with fly screen	16,800.00	unit	1.00	16,800.00	
	Increased thickness of wall, from 150mm to 230mm sandcrete hollow block, with 13mm rendering	400.00	m <sup>2</sup>	120.00	48,000.00	
	Added 100mm rock wool insulation above ceiling	6,200.00	m <sup>2</sup>	200.00	1,240,000.00	
<b>Variant 2</b>	Added ventilation to roof with fly screen	16,800.00	unit	1.00	16,800.00	13%
	Added external shading to windows in the form of 1m overhang	7,560.00	m	18.00	136,080.00	
	Added 50mm insulation to the 150mm hollow block + air gap + 100 brick	7,920.00	m <sup>2</sup>	119.70	948,024.00	
	Change from incandescent to LED lighting	1,050.00	unit	12	12,600.00	
	Improved window from single glazing to double glazing (U = 3.09W/m <sup>2</sup> K)	14,000.00	m <sup>2</sup>	36	504,000.00	
	Efficient appliances	108,000.00	unit	1	108,000.00	
<b>Variant 3</b>	Added DHW solar thermal system	285,000.00	unit	1	285,000.00	35%
	Added PV system: Per solar system including modules, inverters and batteries. Batteries sized for one day of autonomy. Assumed 140Wp/m <sup>2</sup> and cost for 4/Wp	800.00	Wp	7000	5,600,000.00	

<sup>39</sup> Cost sources: Construction cost provided by local Quantity Surveyor based in project experiences. PV system costs provided by Arup from project experience. Only measures with associated construction costs have been included. This applies to all building typologies.

## Multi-apartment block

Multi-apartment   Variant 1		
Improvement measure	Purpose	Possible alternatives
Improved orientation, majority of windows facing N/S	Reduce solar heat gains	Additional external shading (vertical), trees etc.), mitigate solar gains on E&W windows where these cannot be avoided
External shading to windows in the form of 1m overhang	Reduce solar heat gains and direct sunlight into the building	Different shading types e.g. roof overhangs. Planting trees/vegetation
Fluorescent lighting	Reduce lighting energy consumption & internal gains	Metal halide and LED lighting
Behavioural change – turning lights off at night	Reduce lighting energy consumption & internal gains	Photocell sensors can help automate this. Security lights on PIR rather than staying permanently on
100mm rock wool insulation above ceiling and ventilated ceiling void	Reduce heat gain via the roof	Other forms of insulation possible to achieve same level of ceiling insulation $U = 0.328 \text{ W/m}^2$ (or better)
Hollow block wall – 230mm sandcrete hollow block, 20mm air gap, external metal coating	Reduce heat gain via walls	Other forms of construction to achieve $U = 1.21 \text{ W/m}^2\text{K}$

Multi-apartment   Variant 2		
Improvement measure	Purpose	Possible alternatives
Insulated wall 150mm sandcrete block, 50mm insulation, 25mm air gap, 100mm brickwork	Reduce heat gain via external walls	Other forms of construction to achieve $U = 0.7W/m^2$
Double glazed windows	Reduce heat conduction through windows	$U = 3.1W/m^2K$
Clay tile roof rather than metal sheet	Reduce heat convection through roof	
LED lighting	Reduce energy consumption & internal heat gains	
Solar water heating (each apartment has 300 litre cylinder)	Renewable energy generation	
Energy efficient appliances (TV, refrigerator, microwave)	Reduce energy consumption & internal heat gains	

Multi-apartment   Variant 3		
Improvement measure	Purpose	Possible alternatives
100m <sup>2</sup> of PV (i.e. 8.3m <sup>2</sup> per apartment), with battery storage and invertors	Generate renewable energy	Wind turbines and other forms of generation  Smaller amounts of PV could also be installed

The following tables present the cost breakdown for all the measures associated with construction costs for the multi-apartment. Costs have been sourced from a professional local quantity surveyor based on project experience. Cost of the PV system has been provided by Arup based on project experience.

Multi-apartment   Average construction cost		
Unitary cost (Naira/m <sup>2</sup> )	Area	Total cost
145,000	1,200	174,000,000



Multi-apartment   Energy efficiency measures cost breakdown						
Scenario	Measure description	Added cost Naira/unit	Unit	Quantity	Total added cost Naira	% Increase over BAU
<b>Variant 1</b>	Added external shading to windows in the form of 1m overhang	7,560.00	m	100.00	756,000.00	6%
	Change from incandescent to fluorescent lighting	1,300.00	unit	132.00	171,600.00	
	Added 100mm rock wool insulation above ceiling	6,200.00	m <sup>2</sup>	500.00	3,100,000.00	
	Added ventilation to roof with flyscreen	250,000.00	unit	1.00	250,000.00	
	Increased thickness of wall, from 150mm to 230mm sandcrete hollow block, plus air gap and metal cladding	7,920.00	m <sup>2</sup>	747.00	5,916,240.00	
	Added 100mm rock wool insulation above ceiling	6,200.00	m <sup>2</sup>	500.00	3,100,000.00	
<b>Variant 2</b>	Added ventilation to roof with flyscreen	250,000.00	unit	1.00	250,000.00	15%
	Added external shading to windows in the form of 1m overhang	7,560.00	m	100.00	756,000.00	
	Added 50mm insulation to the 150mm hollow block + air gap + 100 brick	7,920.00	m <sup>2</sup>	747.00	5,916,240.00	
	Change from incandescent to LED lighting	1,050.00	unit	132	138,600.00	
	Improved window from single glazing to double glazing (U = 3.09W/m2K)	14,000.00	m <sup>2</sup>	108	1,512,000.00	
	Efficient appliances	108,000.00	unit	132	14,256,000.00	
<b>Variant 3</b>	Added DHW solar thermal system	85,000.00	unit	1	285,000.00	23%
	Added PV system. See bungalow description	800.00	Wp	17500	14,000,000.00	

## Small office

Small office   Variant 1		
Improvement measure	Purpose	Possible alternatives
Improved orientation, majority of windows facing N/S	Reduce solar heat gains	Additional external shading (vertical), trees etc.), mitigate solar gains on E&W windows where these cannot be avoided
Reduced glazing (40% to N/S, 20% to E/W)	Reduce solar heat gains	
External shading to windows in the form of 1m overhang	Reduce solar heat gains and direct sunlight into the building	Different shading types e.g. roof overhangs. Planting trees/vegetation
Ventilated ceiling void	Reduce heat gain via the roof	Other forms of insulation possible to achieve the recommended U
Hollow block wall – 230mm sandcrete hollow block, 20mm air gap, external metal coating	Reduce heat gain via walls	Other forms of construction to achieve $U = 1.21 \text{ W/m}^2\text{K}$
More efficient VAC-VRV system instead of split units. COP= 3.8	Energy efficient cooling	
Occupancy sensors to control lighting	Reduce lighting energy consumption & internal gains	Metal halide and LED lighting
More efficient computers and photocopiers and turned off at night	Reduce lighting energy consumption & internal gains	
Set point increased to 24°C	Reduce A/C energy consumption	

Small office   Variant 2		
Improvement measure	Purpose	Possible alternatives
Insulated wall 150mm sandcrete block, 50mm insulation, 25mm air gap, 100mm brickwork	Reduce heat gain via external walls	Other forms of construction to achieve $U = 0.7 \text{ W/m}^2\text{K}$
Double glazed windows $U = 3.1 \text{ W/m}^2\text{K}$	Reduce heat conduction through windows	
Clay tile roof rather than metal sheet	Reduce heat convection through roof	
LED lighting with occupancy sensors	Reduce energy consumption & internal heat gains	
More efficient VAC (VRV and enthalpy recovery on fresh air) COP=4.4	Energy efficient cooling	

Small office   Variant 3		
Improvement measure	Purpose	Possible alternatives
150m <sup>2</sup> of PV, with invertors (no batteries required)	Generate renewable energy	Wind turbines and other forms of generation  Smaller amounts of PV could also be installed

The following tables present the cost breakdown for all the measures associated with construction costs for the small office. Costs have been sourced from a professional local quantity surveyor based on project experience. Cost of the PV system has been provided by Arup based on project experience.

Small office   Average construction cost		
Unitary cost (Naira/m <sup>2</sup> )	Area	Total cost
185,000	800	148,000,000

Small office   Energy efficiency measures cost breakdown							
Scenario	Measure description	Added cost Naira/unit	Unit	Quantity	Total added cost Naira	% Increase over BAU	
<b>Variant 1</b>	Added external shading to windows in the form of 1m overhang	7,560.00	m	60.00	453,600.00	4%	
	Change from incandescent to fluorescent lighting controlled with occupancy sensors	1,350,000.00	unit	1.00	1,350,000.00		
	Added ventilation to roof with fly screen	250,000.00	unit	1.00	250,000.00		
	Efficient office equipment	1,250,000.00	unit	1.00	1,250,000.00		
	Increased thickness of wall, from 150mm to 230mm sandcrete hollow block, plus air gap and metal cladding	7,920.00	m <sup>2</sup>	342.00	2,708,640.00		
	Reduced glazing	(9,000.00)	m <sup>2</sup>	92.00	(828,000.00)		
	More efficient VAC-VRV system instead of split units. COP = 3.8, 82.5kW cooling	1,189,069.00	unit	1.00	1,189,069.00		
	Added ventilation to roof with fly screen	250,000.00	unit	1.00	250,000.00		
	Added external shading to windows in the form of 1m overhang	7,560.00	m	60.00	453,600.00		
	Clay tile roof; NIGERITE Crete tile + timber carcass	7,450	m <sup>2</sup>	255.00	1,899,750.00		
<b>Variant 2</b>	Added external shading to windows in the form of 1m overhang	7,560.00	m	60.00	453,600.00	9%	
	Added 50mm insulation to the 150mm hollow block + air gap + 100 brick	7,920.00	m <sup>2</sup>	342.00	2,708,640.00		
	Change from incandescent to fluorescent lighting controlled with occupancy sensors	1,350,000.00	unit	1	1,350,000.00		
	Improved window from single glazing to double glazing (U = 3.09W/m <sup>2</sup> K)	14,000.00	m <sup>2</sup>	205	2,870,000.00		
	More efficient VAC (VRV and enthalpy recovery on fresh air) COP:4.4	2,034,715.00	unit	1	2,034,715.00		
	Efficient office equipment	1,250,000.00	unit	1	1,250,000.00		
	Measures from Variant 2						
	Added PV system. Assumed inverters, batteries included. Batteries sized for one day of autonomy. Assumed 140Wp/m <sup>2</sup> and cost for \$4/Wp	800.00	Wp	21,000	VAR 2 cost 16,800,000.00		20%

## Large office

Large office   Variant 1		
Improvement measure	Purpose	Possible alternatives
Improved orientation, majority of windows facing N/S	Reduce solar heat gains	Additional external shading (vertical), trees etc.), mitigate solar gains on E&W windows where these cannot be avoided
<p>Reduced glazing 60% in all orientations</p> <p>Single glazed 6/6 mm air with hard reflective coating:  <math>U=5.6 \text{ W/m}^2\text{K}</math>                      Solar factor= 34%                      Light transmittance= 25%</p> <p>Other parts of façade insulated opaque panels: glass (6mm) + 40mm insulation panel+ glass (6mm)  <math>U=1.1 \text{ W/m}^2\text{K}</math></p>	Reduce solar heat gains	
External shading to windows in the form of 1.5 m overhang	Reduce solar heat gains and direct sunlight into the building	Different shading types e.g. roof overhangs. Planting trees/vegetation
Insulated roof (100mm of polystyrene above asphalt with gravel )	Reduce heat gain via the roof	Other forms of insulation possible to achieve $U = 0.371 \text{ W/m}^2\text{K}$
More efficient VAC-VRV system instead of split units, COP = 3.8	Energy efficient cooling	
Occupancy sensors to control lighting	Reduce energy consumption & internal heat gains	Metal halide and LED lighting
More efficient computers and photocopiers and turned off at night	Reduce energy consumption & internal heat gains	
Set point increased to 24°C	Reduce cooling demand	

Large office   Variant 2		
Improvement measure	Purpose	Possible alternatives
<p>Reduced glazing (40% to N/S and 20% to E/W)</p> <p>Double glazed 6/6mm air with soft reflective coating  <math>U = 2.9W/m^2K</math>                      Solar factor = 36%                      Light transmittance = 65%</p> <p>Other parts of façade insulated opaque panels: glass (6mm) + 40mm insulation panel+ glass (6mm)  <math>U = 1.12W/m^2K</math></p>	Reduce heat conduction through windows	
Enhanced shading in E/W windows in the form of exterior 0.5 m projection louvers	Reduce solar gain through windows	
LED lighting with occupancy sensors & daylighting sensors	Reduce energy consumption & internal heat gains	
More efficient VAC (chiller + efficient fancoils), COP = 4.8	Energy efficient cooling	

Large office   Variant 3		
Improvement measure	Purpose	Possible alternatives
500m <sup>2</sup> of PV, with invertors (no batteries required)	Generate renewable energy	<p>Wind turbines and other forms of generation</p> <p>Smaller amounts of PV could also be installed</p>

The following tables present the cost breakdown for all the measures associated with construction costs for the large office. Costs have been sourced from a professional local quantity surveyor based on project experience. Cost of the PV system has been provided by Arup based on project experience.

Large office   Average construction cost		
Unitary cost (Naira/m <sup>2</sup> )	Area	Total cost
265,000	7,400	1,961,000,000

Large office   Energy efficiency measures cost breakdown						
Scenario	Measure description	Added cost Naira/unit	Unit	Quantity	Total added cost Naira	% Increase over BAU
<b>Variant 1</b>	Added external shading to windows in the form of 1.5m overhang	7,600.00	m	342.00	2,599,200.00	2%
	Add occupancy sensors to fluorescent lightings: 1sensor/50m <sup>2</sup>	12,150,000.00	unit	1.00	12,150,000.00	
	Added insulation to roof – 100mm polystyrene	13,500.00	unit	650.00	8,775,000.00	
	Efficient office equipment	585,000.00	unit	9.00	5,265,000.00	
	Substitute glazing by opaque glazed panels to keep 60% glazed areas (6mm glass + 40mm insulation board)	(1,000.00)	m <sup>2</sup>	700.00	(700,000.00)	
	More efficient VAC-VRV system instead of split units. COP = 3.8	1,189,069.00	unit	9.00	10,701,621.00	
<b>Variant 2</b>	Add occupancy and daylight sensors to lighting and switch to LED	13,728,947.37	unit	1.00	13,728,947.37	3%
	Added external shading to windows in the form of 0.5 louvers	7,500.00	m	189.00	1,417,500.00	
	Added insulation to roof 100mm polystyrene	13,500.00	unit	650.00	8,775,000.00	
	Added external shading to windows in the form of 1.5m overhang	7,560.00	m	342.00	2,585,520.00	
	Substitute glazing by glazed insulated panels 6mm + 40 insulation board to keep 40% glazed areas in N/S facades and 20% in E/W	(1,000.00)	m <sup>2</sup>	1067.00	(1,067,000.00)	
	Improved window from single glazing to double glazing (U = 3.09W/m <sup>2</sup> K)	14,000.00	m <sup>2</sup>	1,200.00	16,800,000.00	
<b>Variant 3</b>	More efficient VAC (VRV and enthalpy recovery on fresh air) COP = 4.4	2,034,715.00	unit	9.00	18,312,435.00	6%
	Efficient office equipment	585,000.00	unit	9.00	5,265,000.00	
	<i>Measures from Variant 2</i> Added PV system. Assumed inverters and batteries included. Batteries sized for one day of autonomy. Assumed 140Wp/m <sup>2</sup> and cost for \$4/Wp	800.00	Wp	70,000	<i>Variant 2 cost</i> 56,000,000.00	

# B Methodology for carbon calculations

The figures provide below are based on the buildings as a whole. Specifically, the annual energy consumption and carbon emissions are for the following:

- Bungalow building composed of two separate dwellings
- Multi-apartment block composed of 12 apartments over 3 floors
- Small office
- Large office

To calculate the carbon emissions resulting from the use of electricity, we have assumed the following:

For residential buildings – that on-site generators produce on average 40% of electricity consumed per year. These will be small petrol generators of approximately 4kW capacity.

For office buildings – that on-site generators produce on average 40% of electricity consumed per year. These will range between 200 to 2,000kW diesel generators.

Where PV generation is part of the generation mix, we have assumed that this technology does not contribute any carbon emissions.

---

40. Carbon factors for fossil fuels do not vary significantly overtime as quality and production process similar. This factor was cross-checked with other sources. Source: IEA, 2011

41. Source: Arup industry experience

42. Source: US EPA, 2005



Table 21: Annual energy consumption and carbon emissions per building typology and variant

Scen-arios	Annual electricity consumption (kWh/year)		Grid Intensity <sup>40</sup> (kgCO <sub>2</sub> /kwh)	Fuel for on-site generator <sup>41</sup>	Fuel Carbon Intensity <sup>42</sup> (kgCO <sub>2</sub> /kWh)	Proportion of electricity generated on-site <sup>41</sup>	Average Carbon Intensity of electricity (kgCO <sub>2</sub> /kWh)	Annual CO <sub>2</sub> emissions (kgCO <sub>2</sub> /year)		
	H&H	H&D						H&H	H&D	
<b>Bungalow</b>	<b>BAU</b>	26,415	26,415	0.44	Petrol	1.55	40%	0.88	23,344	23,344
	<b>Var 1</b>	11,719	11,719	0.44	Petrol	1.55	40%	0.88	10,357	10,357
	<b>Var 2</b>	8,381	8,381	0.44	Petrol	1.55	40%	0.88	7,407	7,407
	<b>Var 3</b>	-	-	0.44	Petrol	1.55	40%	0.88	-	-
<b>Multi-apartment block</b>	<b>BAU</b>	115,400	115,400	0.44	Petrol	1.55	40%	0.88	101,986	101,986
	<b>Var 1</b>	55,954	55,954	0.44	Petrol	1.55	40%	0.88	49,450	49,450
	<b>Var 2</b>	41,194	41,194	0.44	Petrol	1.55	40%	0.88	36,405	36,405
	<b>Var 3</b>	11,694	20,569	0.44	Petrol	1.55	40%	0.88	10,335	18,178
	<b>BAU</b>	215,716	228,992	0.44	Diesel	0.72	40%	0.55	119,023	126,348
	<b>Var 1</b>	128,933	134,923	0.44	Diesel	0.72	40%	0.55	71,140	74,445
<b>Small office</b>	<b>Var 2</b>	92,710	93,445	0.44	Diesel	0.72	40%	0.55	51,153	51,559
	<b>Var 3</b>	57,310	68,695	0.44	Diesel	0.72	40%	0.55	31,621	37,903
	<b>BAU</b>	2,158,416	2,147,066	0.44	Diesel	0.72	40%	0.55	1,190,917	1,184,65
<b>Large office</b>	<b>Var 1</b>	1,055,436	1,373,972	0.44	Diesel	0.72	40%	0.55	582,342	758,096
	<b>Var 2</b>	514,257	538,839	0.44	Diesel	0.72	40%	0.55	283,744	297,307
	<b>Var 3</b>	380,257	442,339	0.44	Diesel	0.72	40%	0.55	209,809	244,063

# Organisations represented in the Workshops organized for the development of the BEEG

AMAC – Abuja Municipal Area Council

Anglia Ruskin University, UK

ARCHON – Architects Registration Council of Nigeria

Blue Camel Energy

Cappa and D'Alberto Plc

CORBON – Council of Registered Builders of Nigeria

COREN – Council for the Regulation of Engineering in Nigeria

Daily Trust Newspapers of Nigeria

ECN – Energy Commission of Nigeria

FCDA – Federal Capital Development Authority

FHA – Federal Housing Authority

FMBN – Federal Mortgage Bank of Nigeria

FUT Minna – Federal University of Technology, Minna Niger State

FMPWH – Federal Ministry of Power, Works and Housing (Housing)

GBCN – Green Building Council of Nigeria

GIZ – Deutsche Gesellschaft für Internationale Zusammenarbeit (German Development Cooperation)

NBRRI – Nigerian Building and Road Research Institute

NCECC – National Centre for Energy Efficiency and Conservation

NIA – Nigeria Institute of Architects

NESP – Nigerian Energy Support Programme

NSE – Nigerian Society of Engineers

NUC \_ Nigerian Universities Commission (Energy Department)

Ove Arup & Partners

PHCN – Power Holding Company of Nigeria

Population Council of Nigeria

SON – Standards Organisation of Nigeria

UN-HAPSO – United Nations Habitat Programme Support Office, Nigeria

YSEMA-Yobe State Emergency Management Agency (SEMA, Yobe State)

