

# Micro Hydropower in Nepal: A Journey from Stand-alone System to Distributed Generation

Jiwan Kumar Mallik  
AEPC/RERL  
jiwan.mallik@aepe.gov.np

Satish Gautam  
AEPC/RERL  
satish.gautam@aepe.gov.np

Surendra Mathema  
Preesu Electronics P. Ltd.  
surendramathema@gmail.com

Binod Koirala  
ECN part of TNO, Netherland  
binod.koirala@tno.nl

Hitendra Dev Shakya  
NEA  
hitendradev@hotmail.com

**Abstract** - Nepal is known for its successful rural electrification efforts through community owned and managed standalone micro hydropower projects (MHP) that have helped transform its rural economy. Unfortunately, as soon as the national grid reaches a micro hydro catchment area, things start falling apart. For various reasons, people's preference is the grid and eventually switch over from MHP which then lies idle and ultimately abandoned. A recent survey carried out by the Alternative Energy Promotion Centre (AEPC) shows that about 8% of the MHPs in Province 1 have shut down. The number of abandoned plant would be much larger if MHPs of less than 10kW capacity are also considered. Thus, the Government of Nepal came-up with the policy for grid interconnection of MHPs of less than 100kW capacity. This opportunity of transforming a standalone system to grid connected system has several advantages for both the utility grid and the MHP, the grid gets power injection near the load centers whereas MHP earns additional revenue. The technological difference between grid interconnection of MHP and other hydropower projects shall be discussed in detail in the Nepalese context. A MATLAB simulation analysis is presented to demonstrate the technical viability of the interconnection in the 11kV feeder line. Moreover, financial and economic analysis of the grid interconnected systems is also discussed. This paper also focuses on how droop features of Electronic Load Controller (ELC) could have managed the proportional load sharing among the MHP plants if such ELC with droop features were available.

**Keywords** - *Micro Hydro Plant, Distributed Generation, Electronic Load Controller, Droop Characteristics*

## I. INTRODUCTION

Nepal is known for its successful rural electrification efforts through community owned and managed standalone MHP that have helped transform a large part of its remote and hilly districts. Nepal's green energy, which totals more than 36 MW today, has not only brought electricity to more than 350,000 families in remote areas away from the grid, it has created an environment conducive for new economic activities, relieved people of drudgeries, improved their health and helped better children's education.

Unfortunately, as soon as the national grid reaches a MHP catchment area, things start falling apart. Community is divided among those supporting the expansion of the national

grid and the ones maintaining the MHP that serves them well. Some people eventually start using grid electricity thus further depriving an already financially stressed off grid system. Consequently, many MHP installations cannot compete with the grid and stop their operations. In some cases, however, it has been observed that the communities have reverted to MHP as the grid is plagued with a lot of outages. Among others, this unfortunate situation is due to the lack of coordination between the two largest governmental organizations involved in rural electrification, Nepal Electricity Authority (NEA), the single off-taker in Nepal and AEPC responsible for off grid renewable energy. Renewable Energy for Rural Livelihood (RERL), a joint project of AEPC and UNDP started working on the grid interconnection of MHPs in 2011. After the policy breakthrough in July 2014, the first grid interconnection of MHP was realized on 11 January 2018. This opportunity of transforming a standalone system to grid connected system has several advantages for both the utility grid and the MHP, the grid gets power injection near the load centers by reducing line losses and enhancing power quality whereas MHP earns additional revenue.

The frequency control strategy adopted in MHP is different from large hydro [3-4]. The frequency balancing in MHP through load control is not only economical but also robust compared to flow control. However, for grid interconnection of MHP, the modified load control has been adopted instead of governor. This paper also discusses how power-frequency droop control strategy would help to share the proportional load among the interconnected MHPs. Further, the modified voltage control strategy for grid interconnected MHP has been elaborated in detail. The financial analysis has been presented in the paper to showcase the viability of the grid interconnection of MHP in the Nepalese context. The overall purpose of this paper is to present remarkable achievement in the MHP sector of Nepal.

## II. TECHNICALITIES OF GRID INTERCONNECTED MHP

The MHP has different control mechanism than large hydro to manage voltage and frequency. The flow control based governor in large hydro maintain frequency by controlling water flow in accordance to required power generation whereas in isolated MHP, load controller based on ELC

maintained the frequency by balancing generated power between dummy/ballast load and consumer load. The Fig. 1 depicts MHP governing strategy in isolated mode. The generated power is constant as the water flow in the turbine is constant unless there is manual operation of turbine valve. Initially, the consumer load is zero, thus ELC diverts all power to ballast load. Similarly, when consumer load is getting increased, the ballast load is getting decreased to maintain the generated power constant [3]. In large hydro, the power generation can be varied in accordance to flow of water in the turbine. For grid interconnection, it's obvious that better frequency control can be achieved in flow controller based governor. While ELC creates harmonics distortion in the power system and the same ELC used in the existing isolated MHP can't be used for grid interconnection. The limitation of ELC in the already built MHP poses another challenges for grid interconnection.

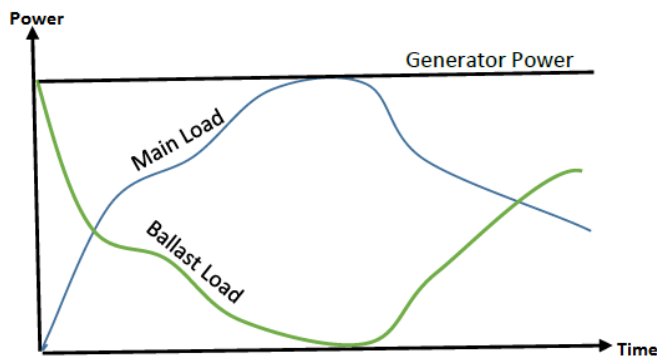

Fig. 1. Governing Mechanism of MHP using ELC

### III. THE ELC TECHNOLOGY FOR ISOLATED MHP SYSTEM

The ELC is an electronic device that keeps the speed of synchronous generator constant at varying consumer load conditions. The generator is driven by unregulated turbine with constant power output and a dummy/ballast load is connected across the generator terminals to dump the excess of power generated. When the consumer's load changes, frequency of generated power changes. This changes of frequency is sensed and compared with the reference frequency and error so obtained is utilized to control power consumed by ballast load so that generator always operates at its full rating, resulting in constant speed.

Fig. 2 shows the schematic diagram of the proposed scheme. The generator supplies power to the three phase consumer load and the ELC with resistive ballast load is connected in parallel to the load through Thyristor. When the load of the consumer is changed with unbalanced loading, the frequency and per phase load current changes. The frequency and the load currents of each phase have to be sensed. However, the control mechanism in Nepalese make ELC doesn't have current sensing presently. Then the firing angles of Thyristor of respective phases are calculated and changed to make constant

frequency and balanced generator terminal currents.

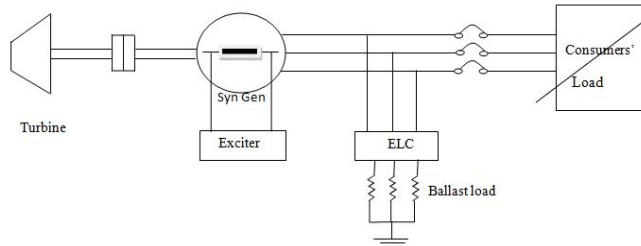

Fig. 2. Schematic diagram of ELC used for Isolated MHP

In other word, the ELC proposed in the scheme consumes power in such a way that the excessive power of particular phase is dissipated in the ballast of the respective phase. In case of no load condition, the ELC can dissipate all active power generated in the ballast load. Fig. 3 shows the control strategy of the ELC practiced in Nepal.

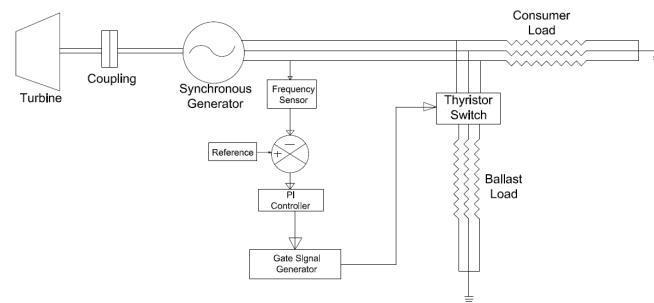

Fig. 3. Control Strategy of ELC practiced in Nepal

### IV. ELC FOR GRID INTERCONNECTION

The disadvantage of phase angle based firing of thyristor causes harmonics current injection in the system which sometime may cause hunting (sudden rise and fall of electrical parameters in the system) in the system too, especially during the condition of firing at 90°. The harmonic causes the problem for regular operation of grid interconnection MHP, more specifically while MHP disconnected from the grid during any abnormalities in the utility grid.

While MHP interconnecting with utility grid, the ELC is deactivated during the grid interconnection. As soon as the MHP become islanded with the grid (in the event of any unusual fault in the grid), ELC again comes into action and diverts the generated power to the ballast load. During this transition, the voltage rises to unacceptable limit. This is one of the major technological constraints faced while interconnecting MHP to the grid. One possible reason could be low inertia of MHP. For the first grid interconnected MHP of Syaurebhumii 23kW, the inertia of turbine-generator system is large thus the voltage rise during the transition is not significant. However there is problem of voltage rise seen with the 40kW Leguwa Khola MHP in Dhankuta. The Single Line Diagram of grid interconnected MHP is shown in Fig. 4.

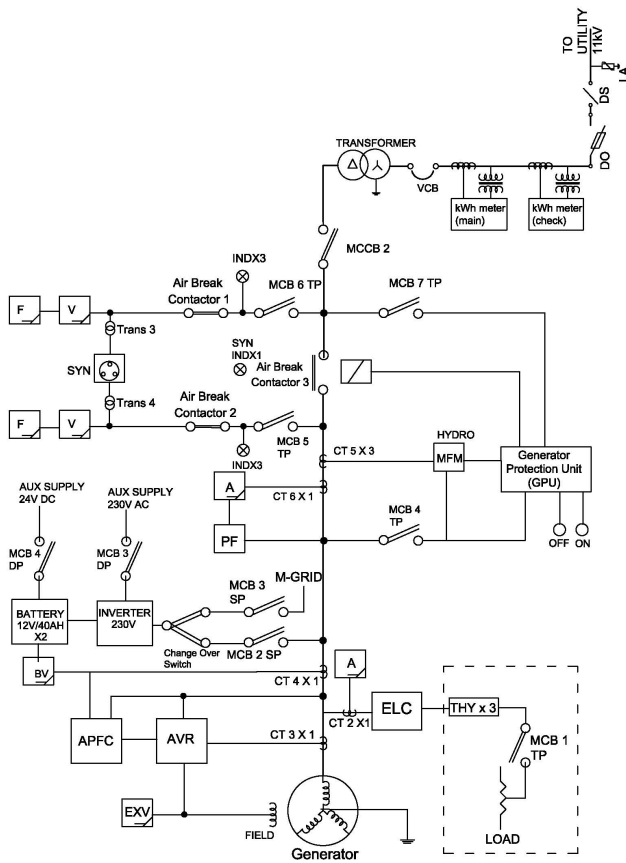

Fig. 4. Single Line Diagram of Grid Interconnection of MHP

Moreover, MHP to MHP interconnection requires droop featured ELC which will ensure proportional sharing of active power of ballast based on its capacity. Nepal has piloted two MHP to MHP interconnection projects, i) Baglung Mini Grid in central Nepal, ii) Gulmi Mini Grid in central Nepal and the third one, Taplejung Mini Grid in eastern Nepal is under construction. Baglung Mini Grid interconnects 6 MHPs with capacity ranging from 9kW to 23kW with total cumulative capacity of 107kW whereas Gulmi Mini Grid interconnects two MHPs of capacity 135kW and 83kW and Taplejung Mini Grid interconnects 5 MHPs with capacity ranging from 36kW to 95kW with total cumulative capacity of 326kW, a 500kW MHP will be interconnected in the system once completed. However, the technology used in these projects has limitation of proportional sharing of active power. In Fig. 5,  $\Delta P1$  for MHP 1 ballast differs from the  $\Delta P2$  of MHP2 ballast for the same frequency changes. This is possible because of different slope of power-frequency curve of ballast i.e. higher the MHP capacity, lower the slope (MHP2) and vice versa. Usually, the droop varies from 2% to 12%. In MHP to MHP interconnected Mini Grids the consumer loads are not shared in proportion to ballast capacities which could result in conflicts among owners on revenue sharing. Thus, further research would be required for droop featured ELC for MHP to MHP interconnection.

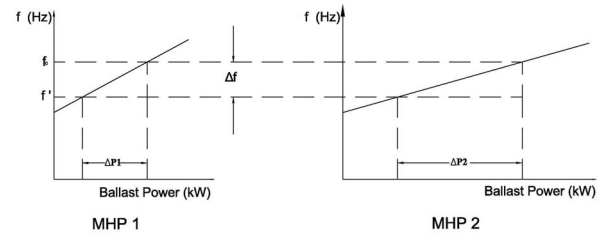

Fig. 5. p-f droop for parallel operation of MHP

## V. AUTOMATIC VOLTAGE REGULATOR (AVR)

The synchronous generator has an exciter, which provides a constant excitation to produce normal rated terminal voltage at full load and it is capable of generating the reactive power too. Synchronous generators used in Nepal for MHP has compounding transformer with built in electronic AVR for the brushless excitation system. The primary winding of compounding transformer (which also acts as current winding) is connected in series with the generator output terminal so that the change of the load in the consumer can be reflected into the excitation of the generator. The secondary winding (which also act as voltage winding) having adjustable tap from -20% to +20% with the step of 5% is connected to three phase bridge rectifier which helps to change the on-load output voltage of the generator. The adjustable air-gap in the compounding transformer is provided for no-load voltage regulation. The DC current output from three phase Bridge Rectifier directly feeds into the "Compounding Field Winding" which gives larger current than necessary. In addition, there is an Electronic AVR having droop current transformer (CT) connected in 'B' phase of generator and phase sensing voltage from 'R' and 'Y' phase of generator provided to regulate the "Regulation Field Winding" of exciter current. The Electronic AVR help to maintain the expected generator voltage. The "Auxiliary Field Winding" is used for supplying power to the "Compounding Field Winding" and "Regulation Field Winding". Furthermore, a single phase Bridge Rectifier is used to switch-over in manual mode in case of failure of "Electronic AVR". This architecture has been used in two interconnection projects having generator rating more than 100kVA. The Electronic AVR is not provided in case of less than 100kVA size of generator. In that case a separate compatible electronic AVR is required for interconnection of MHP with the utility grid. Another solution for less than 100kVA generator could be a variable resistor in series with positive terminal of three phase bridge rectifier which will regulate the DC excitation and thus regulation in the generator output voltage. The latter case has been deployed in 40kW Leguwa MHP for grid interconnection while a Stamford AVR has been used in 23kW Syaurebhumu MHP. The architecture of excitation system is shown in Fig. 6.

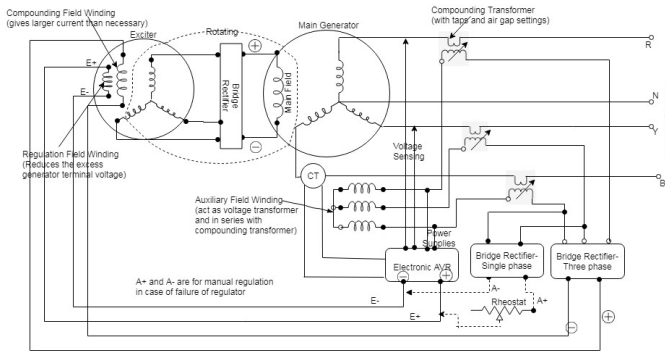

Fig. 6. Architecture of Excitation System in MHP

## VI. MATLAB SIMULATION OF GRID INTERCONNECTED MHP

A MATLAB simulation is conducted for the 23kW Syaurebhumi MHP. The parameters of components used in the simulation are given in Annex I. The complete simulation system is given in Fig. 7.

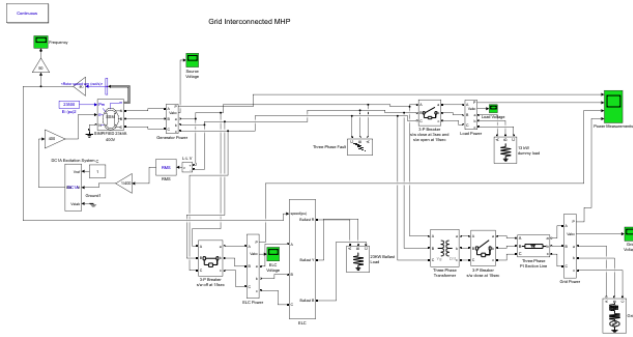

Fig. 7. MATLAB Simulation

The main objective to conduct the simulation is to check the functionality of the ELC deployed in the project. During the grid connected mode, the ELC is deactivated. In case of any abnormality in the grid, the grid would be isolated from the generating system. In case of grid outage, the ELC diverts the generated power to dummy load. If the consumer load is also connected in the islanded mode, the ELC also supplies the power to the consumer and only excess power is diverted to the dummy load, also called ballast load. The detailed parameters used in the simulation are given in Appendix I. To determine protection system parameters, reference from Sri Lanka and UK were considered [11] and [12].

## VII. SIMULATION RESULTS

To check the functionalities and robustness of ELC for the generating system of 23kW, results are obtained for different scenarios for simulation time of 16 seconds. Up to 3 seconds, the generator supplies full power to dummy load through the ELC. At the event of 3sec, when consumer load of capacity 13kW is switched-on, the ELC automatically sets the firing angle of thyristor in such a way that it diverts excess power of 10kW to the dummy load. The generator power of 23kW output remains constant as the turbine input is constant. Furthermore, the generator is synchronized with the grid at 15sec and all the generated power of 23kW is evacuated to

grid and the ELC is deactivated. As the consumer also gets power through the grid, no power is consumed by the consumer load.

To check the robustness of the ELC, a three phase to ground fault for 5ms has been created at 9sec. The result obtained is satisfactory as the generator parameters including power, frequency and voltage settled down after 3 seconds. The stabilizing time also depends upon the inertia constant of the generator which is very low in this case, thus it takes 3 seconds to stabilize the parameters. A zoom-in view of generator voltage during the transition of synchronization at 15sec is shown in Fig. 8(f). It can be clearly seen that there is voltage distortion before 15sec while generator was supplying power to dummy load through ELC. There is no such voltage distortion while generator continued to supply to the grid when the ELC is deactivated. This is one of the drawbacks of the frequency control through the ELC.

The phase angle based firing of thyristor causes harmonics current injection in the system which sometime may cause hunting (sudden rise and fall of electrical parameters in the system) in the system too, especially during the condition of firing at phase angle of  $90^\circ$  of sine wave. The harmonic causes the problem more specifically when the MHP is disconnected from the grid due to abnormalities in the grid. There is also a voltage spike seen just after 15sec which is also caused by lower inertia of the generator. In the practical scenario of grid interconnection of 4 different MHPs so far carried out in Nepal, it had been seen that the electrical parameters are unstable for lower inertial machine whereas somewhat stable with machine with higher inertia. The PI controller tuning for ELC has been carried out by hit-and-trial basis. Thus, the gain obtained may not be optimal, which is one of the limitations of this paper. Evolutionary Algorithm (EA) could have been deployed to find out optimal gain of PI controller which could be the future scope of work.

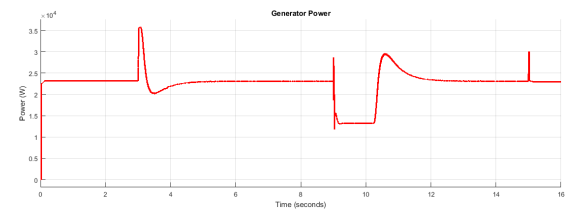

Fig. 8 (a). Generated Power

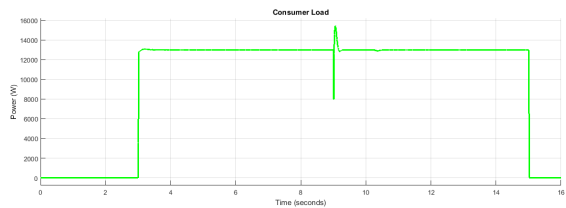

Fig. 8 (b). Consumer Load

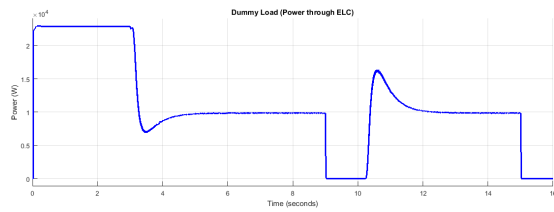

Fig. 8 (c). Power to Dummy Load

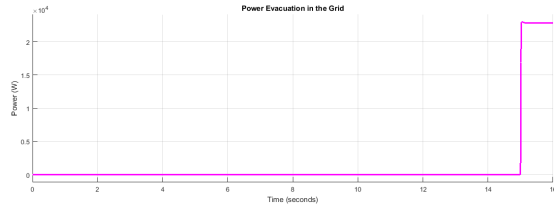

Fig. 8 (d). Power Evacuation into the Grid

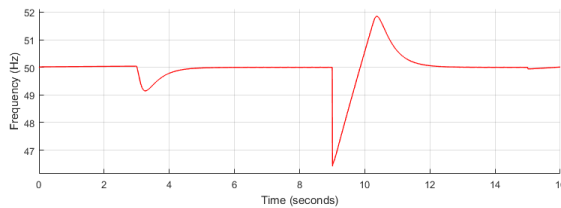

Fig. 8 (e). Generator Frequency

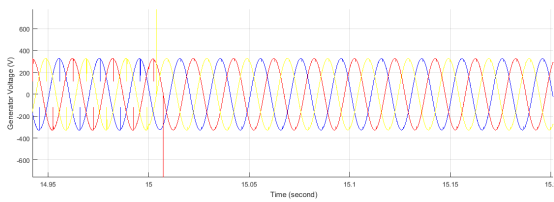

Fig. 8 (f). Generator Voltages

## VIII. FINANCIAL ANALYSIS OF GRID INTERCONNECTED MHP

Grid interconnection cost mainly varies with the distance between the grid and the MHP. If the grid is very close to powerhouse of MHP, the interconnection cost at 11kV is around NPR 3 million irrespective of capacity of MHP. In the financial analysis, following assumptions are made; 70:30 Loan to Equity ratio, interconnection is not subsidized, loan payback period is 7 years, loan interest rate is 12%, discount rate of 10%, capital cost of MHP is not considered, plant load factor of 80% (varies on the condition of MHP infrastructure and grid condition), PPA rate of NPR 4.8/kWh for 8 months and NPR 8.4/kWh for 4 months, PPA escalator of 3% for 8 times, 10% of Income Tax after 10 years and project period of 15 years after interconnection with the grid. With these assumptions, a sensitive analysis was carried out which is discussed below.

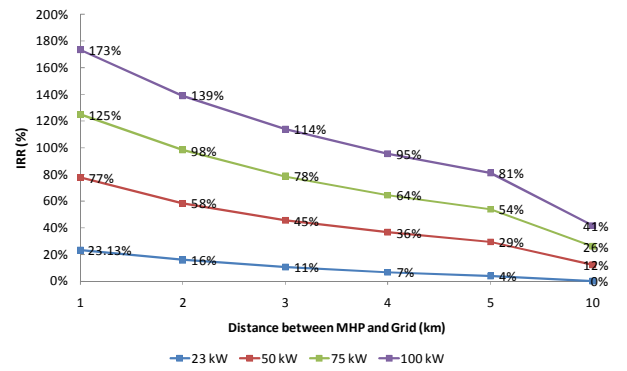

Fig. 9 (a). Internal Rate of Return (IRR) vs Interconnection Distance

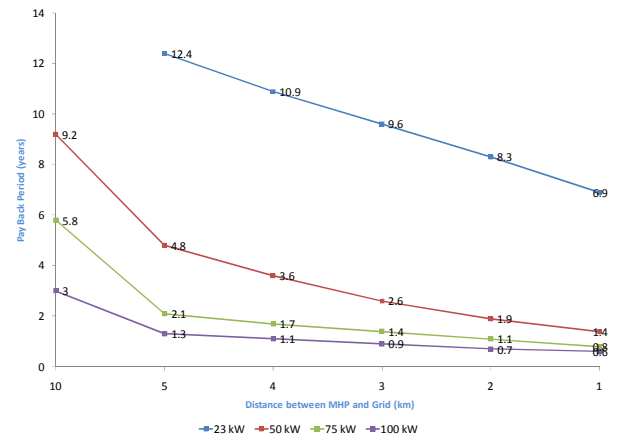

Fig. 9 (b). Payback Period vs Interconnection Distance

It can be seen that an interconnection project is feasible even at 23 kW if the interconnection distance (distance between MHP powerhouse and nearest point of interconnection with the grid of 11kV) is 1 km, for this scenario, the project's internal rate of return (IRR) is 23.13% and the payback period is 6.9 years. In case of a 100kW MHP, the IRR is 41% and the payback period is 3 years even at the interconnection distance of 10km. In nutshell, grid interconnection of existing MHP (considering only cost of interconnection) is financially viable for projects above 20kW capacity if the interconnection distance is less than 1km. However, the government needs to provide financial support for grid interconnection of MHPs until interconnection technology is mature and required equipment are widely available in the market.

## IX. CONCLUSION

It has been observed that the MHPs, built mainly to provide electricity access to rural communities, are abandoned when the grid encroaches their service area. The technical and financial analysis presented in this paper show that grid interconnection of MHP is a viable solution to utilize already invested national resources. The pilot grid interconnection of the 23 kW Syaurebhumu MHP has clearly demonstrated that the model is both technically feasible and financially attractive paving way for similar interconnections of hundreds of other MHPs. Furthermore, in the 23 kW of Syaurebhumu MHP, it

was observed that the voltage of the feeder line was increased by 2% at point of common coupling. Thus, it can be concluded that the distributed generation (grid interconnected system) has not only minimized the transmission and distribution losses but also improved the quality and reliability of the distribution system. However, there still are some policy and institutional gaps that have to be addressed for wider adaptation of this innovative solution.

The ‘permit/license’ regime prevalent for grid interconnection in Nepal has to be simplified before a large number of rural communities come forward to take advantage of government’s policy to interconnect MHPs of less than 100kW. Requirements and processes such as Connection Agreement, PPA, Operating Procedure, Testing and Commissioning Format, etc for the MHPs and hydropower projects up to 25 MW are the same. In MW scale projects, there are dedicated staff to ensure that all requirements are addressed to get approvals. But for an MHP located in rural parts, these lengthy processes become hassles and in some cases have preferred to abandon their MHPs rather than going through the difficult and time consuming processes. In Sri Lanka, the off-taker, Ceylon Electricity Board (CEB) has simplified the processes for grid interconnection of MHP by making a Standard PPA.

Finally, though there is a genuine potential to interconnect hundreds of distributed generation plants with the national grid and improve its reliability and quality in Nepal, government policies and procedures need to be simplified before the owners of these MHPs come forward to interconnect their systems with the grid.

#### ACKNOWLEDGEMENT

Authors would like to thank both AEPC and UNDP Nepal for putting generous effort to make the pilot grid interconnection project in Nepal a success. We are also grateful to our colleagues in AEPC/RERL for useful discussions on the topic of this paper.

#### APPENDIX I

##### Generator

Nominal power = 23kW (this value is based on considering generator loss incurred by resistive losses only)

Line to line voltage = 400V; Frequency = 50 Hz

Mechanical power input =23.5kW; Inertia Constant =5 kg/m<sup>2</sup>

Damping Factor = 0.01; No. of pole pairs = 2

##### Excitation System

$K_a = 200$   $T_a = 0.0001s$

##### Electronic Load Controller

$K_p = 100$   $K_i = 180$

##### Network parameter (pi section line)

$R_1 = 0.01273 \Omega/km$ ,  $L_1 = 0.1 \text{ mH/km}$

$R_0 = 0.1864 \Omega/km$ ,  $L_2 = 1.1264 \text{ mH/km}$

Length of Line = 1km

TABLE I. PROTECTION SYSTEM PARAMETERS FOR GRID INTERCONNECTED 23kW SYAUREBHUMI MHP

Parameter	Value
Rated Power Plant Power	27kW*
Rated Current at 400V generation	48A
Nominal Voltage	390V
Nominal RPM of Generator	1500
Nominal Frequency	50Hz
Over Current	110% for 20sec; 120% for 10sec; 130% for 3sec; 140% for 1sec
Generator Over Voltage	120% for 3sec
Generator Under Voltage	75% for 5 sec
Generator Over Frequency	102.5% for 3sec; 110% for 1sec
Generator Under Frequency	97.5% for 3sec; 90% for 1sec
Grid Over Voltage	110% for 5sec
Grid Under Voltage	90% for 5 sec
Grid Over Frequency	102.5% for 3sec; 110% for 1sec
Grid Under Frequency	97.5% for 3sec; 90% for 1sec
Rate of Change of Frequency (ROCOF)	10 Hz/sec; 6 period
Vector Jump	15 degree
Reverse Power (% of rated power)	5%
Maximum allowable frequency difference for static synchronization	0.1Hz
Maximum allowable voltage difference for static synchronization	5%
Phase window for static synchronization	15 degree

\*Plan to upgrade MHP to 27 kW by increasing flow.

#### REFERENCES

- [1] Padoan, A.C.; Kawkabani, B.; Schwery, A.; Ramirez, C.; Nicolet, C.; Simond, J.-J.; Avellan, F.; , "Dynamical Behavior Comparison Between Variable Speed and Synchronous Machines With PSS," Power Systems, IEEE Transactions on , vol.25, no.3, pp.1555-1565, Feb. 2010.
- [2] Mallik J. K., "Reducing the effect of vortex rope oscillation on hydro units by power system stabilizer designed using Genetic Algorithm," 2011 Annual IEEE India Conference, Hyderabad, 2011, pp. 1-4.
- [3] S. K. Rai, O. P. Rahi and S. Kumar, "Implementation of electronic load controller for control of micro hydro power plant," 2015 International Conference on Energy Economics and Environment (ICEEE), Noida, 2015, pp. 1-6.
- [4] I. Salhi, S. Doubabi and N. Essounbouli, "Fuzzy control of micro hydro power plants," 5th IET International Conference on Power Electronics, Machines and Drives (PEMD 2010), Brighton, UK, 2010, pp. 1-6.
- [5] P. Kundur, Power System Stability and Control, McGraw-Hill 1994.
- [6] P. W. Sauer and M. A. Pai, Power System Dynamics and Stability. Englewood Cliffs, NJ: Prentice-Hall, 1998.
- [7] HPNet Website "Impact of practice-to-policy dialogue: Nepal’s first grid interconnected micro hydro project," Hydro Empowerment Network, Feb 2018.
- [8] World Bank Group ESMAP "Nepal - Scaling up Electricity Access through Mini and Micro Hydropower Applications, September 2014.
- [9] UNDP Website, "Power to the people: Breakthrough in micro-hydro prospects", Kathmandu Nepal, February 2018
- [10] Adam Harvey, Micro Hydro Design Manual
- [11] Cylon Electricity Board, Sri Lanka, "Guide for Grid Interconnection of Embedded Generators Part I and Part II" December 2000
- [12] Energy Network Association, Recommendations for the Connection of Generating Plant to The Distribution Systems of Licensed Distribution Network Operators, London, Issue 3 Amendment September 2015
- [13] David Roberts, Development Of Standardised Control And Connection Systems for Mini Grid Applications, 2002