

CONSTRUCTION MANUAL FOR THE FIREWOOD SAVING ROCKET BAKING OVENS



MINISTRY OF ENERGY AND MINERAL DEVELOPMENT
PROMOTION OF RENEWABLE ENERGY & ENERGY EFFICIENCY PROGRAMME

With the Support of the German Technical Cooperation



THE REPUBLIC OF UGANDA

MINISTRY OF ENERGY AND MINERAL DEVELOPEMNT



gtz

November 2008

Editor:

Rosette Komuhangi Kabuleta

Text, Technical Diagrams and Photographs by:

Leonard Mugerwa & Joseph Kirule

Figures by:

Haruna Lubwama

Advisory:

Philippe Simonis (GTZ – PREEEP)

John Kuteesakwe (GTZ – PREEEP)

Godfrey Ndawula (MEMD)

Published by:

Ministry of Energy and Mineral Development (MEMD)

Promotion of Renewable Energy and Energy Efficiency Programme (PREEEP)

Cover Page: Designed by Harunah Lubwama**Date:**

November 2008

© 2008 MEMD - PREEEP

First Edition November 200 (Not Published)

Second Edition November 2008

Table of Contents

Acknowledgement.....	iii
Introduction	iv
The Technical Modifications in the Rocket baking oven Design.....	v
BASIC FACTS ABOUT THE ROCKET BAKING OVENS	vii
Advantages of using the Institutional Rocket Stoves.....	vii
HOW THE OVEN WORKS.....	viii
2.0 Things to Consider Before Constructing the Rocket Baking Oven	1
PART 1.....	3
SINGLE DECK ROCKET BAKING OVEN.....	3
3.0 Oven Construction Materials	3
3.1 Brickwork.....	3
3.2 Metal Oven Box Fabrication	4
4. Materials Purchase and delivery	4
4.1 The Firewood Rocket Oven Drawing.....	5
5.0 THE BRICK WORK.....	6
5.1 Determining the size of the oven base	6
5.1.1 Determining the combustion chamber position and size	7
5.6 Calculating the combustion chamber height.....	9
6.0 THE METAL BOX / BAKING CHAMBER	16
PART 2:.....	34
8.0 DOUBLE DECK ROCKET BAKING OVEN	34
8.1 DOUBLE DECK ROCKET BAKING OVEN	35
9.0 USING THE OVEN.....	36
9.1 Efficient baking practices.....	36
9.2 Cleaning the oven	36
9.3 Oven maintenance and repair	37

Acknowledgement

This publication is attributed to the work of the Ministry of Energy and Mineral Development who perceive this as an effort to follow up the energy Policy goal of meeting the energy needs of Uganda's population for social and economic development in an environmentally sustainable manner.

Appreciation goes to GTZ – Energy Project for funding this publication and the subsequent developments in Biomass Energy Technologies (BETs).

Special tribute goes to Mr. Peter Scott of Aprovecho Research Center, Oregon, USA, who cooperated with GTZ –PREEEP during the research work on the rocket – elbow combustion chamber and supporting its adaptability to the local Ugandan setting.

The Uganda Industrial Research Institute (UIRI) for their cooperation with MEMD –EAP that made it possible for the research work to be performed at their premises and to their Bakeries department. UIRI carried out the field survey on baking ovens and the oven performance tests.

Introduction

Uganda faces a biomass energy crisis marked by an increasing imbalance between the supply and the demand for the firewood by households, institutions and commercial industries. One of the most effective strategies to sustainably contribute towards the reduction of this problem is through an extensive dissemination of biomass energy efficient technologies.

The biomass energy efficient technologies have been developed to improve energy efficiency for household, institutional and industrial practices. They include the domestic and institutional firewood stoves and the firewood baking oven. The Rocket baking ovens have overall efficiency of over 50% (average) compared to the traditional baking ovens at approximately 15% and leads to fire wood savings of over 80%.

These rocket baking ovens help the users to have financial savings of 60-90 % when compared to the traditional bread baking ovens. This implies that the amount of money spent on firewood by a baker in one week with a traditional baking ovens can be used for 9 weeks with the rocket baking ovens. Another advantage of using the rocket baking ovens is the fact that the spent investment on oven construction can be recovered in a relatively short time through money saved from firewood savings.

The main objective of developing the improved rocket bread baking ovens is to achieve relatively efficient firewood combustion and maximising heat transfer to the baking products.

The purpose of this manual is to give to oven fabrication artisans a practical tool to use in construction of rocket baking ovens of all sizes.

The Technical Modifications in the Rocket baking oven Design

Following the impressive performance of the prototype rocket bread baking ovens in comparison with the traditional ovens, the Ministry of Energy and Mineral Development (MEMD) through the GTZ-Energy Project (PREEEP), has supported private producers to disseminate several rocket baking ovens to support institutions. A survey across selected bakeries using improved rocket baking ovens, covering both the entrepreneurs and the bakery workers, reported significant benefits that include:

- Increased efficiency in firewood use and to reduce environmental degradation through the adoption and optimum utilisation of the rocket baking ovens.
- Improved the working conditions of the bakery staff that were previously exposed to the dangerous smoke and intense heat emission from the traditional baking ovens.
- Reduction in baking time and better quality.
- Reduction in indoor air pollution because of reduced smoke emission.

However it was also noted that several rocket ovens were damaged due to limited use and subsequent crashing of the firewood shelves. The other challenge was that most of the oven boxes get destroyed at the bottom centre due to direct exposure to strong heat from the combustion chamber.

In a GTZ regional workshop on household energy¹ held at Mulanje Malawi in March 2007, several technical aspects were highlighted that required a design review in order to enhance oven performance, durability and user satisfaction.

The proposed modifications included:

- Introducing the bypass air inlet in the design as a replacement for the firewood shelf which is easily destroyed by the fire
- Incorporating a charcoal grate in the combustion chamber to trap the large hot coals to enhance their combustion prior to becoming ash
- Fitting a thick enough mild Steel (MS) Plate as a secondary shield from direct fire at the bottom of the oven box.
- Sealing the oven top with removable insulated laminated tops with provisions for letting out the exhausts to minimise the indoor air pollution and to allow for oven cleaning during maintenance.
- Installing the oven in an assembling format for easy maintenance and repair

It was concluded that for improved performance, the rocket baking ovens should henceforth be disseminated with the features described above. It is recommended that such ovens are constructed by qualified technicians who have considerable experience in the technical specialities of masonry / building construction, metal fabrication and industrial ceramics.

This revised rocket baking oven manual (November 2008 edition) describes the step-by-step construction procedure of the rocket baking oven.

¹ GTZ Report : GTZ Workshop on Household Energy, Mulanje, Malawi, 8 – 13th March 2007

Disclaimer

Whereas relative to the traditional bread baking oven the rocket baking ovens are believed to offer significant benefits to the user(s) including firewood savings, reduced baking time and reduced indoor air pollution and whereas this oven construction manual is believed to be a useful tool for instruction in the procedure for the construction of rocket baking ovens, neither the Uganda Ministry of Energy and Mineral Development nor the German Technical Cooperation assumes responsibility for the completeness or usefulness of the information herein. Additionally neither the Uganda Ministry of Energy and Mineral Development nor the German Technical Cooperation assumes liability in respect of any claim(s) that may arise in the event of any injuries and / or damages that may occur during the design, construction, use, misuse, maintenance and / or malfunction of any ovens that may be constructed on the basis of the design or procedure described herein.

BASIC FACTS ABOUT THE ROCKET BAKING OVENS

The rocket baking ovens are able to achieve maximum transfer of heat to the baking products because they heat at least 90% of the baking box surface area and have insulation around the combustion chamber and fire passages.

Advantages of using the Institutional Rocket Stoves

1. Saves money: A baker who previously used 100,000/= worth of wood fuel with the traditional oven can now use only 10,000/= with the rocket baking oven per week.

2. Time saving: The ovens require about 30-45 minutes for preheating and only 15 minutes for actual baking of buns. This is unlike the traditional baking ovens which require 4 hours for preheating.

3. Less smoke: Because of their design, the rocket ovens produce very little smoke. Only a little smoke is produced during the lighting process or if wet wood is used. The baked products are not contaminated with smoke and other effluents of combustion such as ash.

4. Safe and Easy to use: Once lit, the rocket oven fire will not go out unless the user stops adding firewood. There is also *no need* to blow at the flame to keep the fire alight. Rocket ovens are safer to use because the fire is shielded. There is less likelihood of accidents or burns to the baker.

5. Good Heat Distribution: The rocket oven evenly distributes heat around the baking chamber meaning better quality products.

6. Environmentally Friendly: The rocket baking ovens use less firewood and therefore have less impact in terms of deforestation. They offer less pollution to the environment because of their almost smokeless operation.

HOW THE OVEN WORKS

Fig: 1 below shows a sectioned front view of the oven and how it is intended to function.

The bread is enclosed in a metal box / baking chamber which prevents it from getting contaminated with smoke, ash and hot gases.

The bottom, sides and top of the baking chamber are exposed to the fire, which result into increased heat transfer.

The fired clay tiles are used for heat retention.

The tray rests on the mesh so that heat is not directly transferred to the baking products through conduction thus minimising the risk of burning.

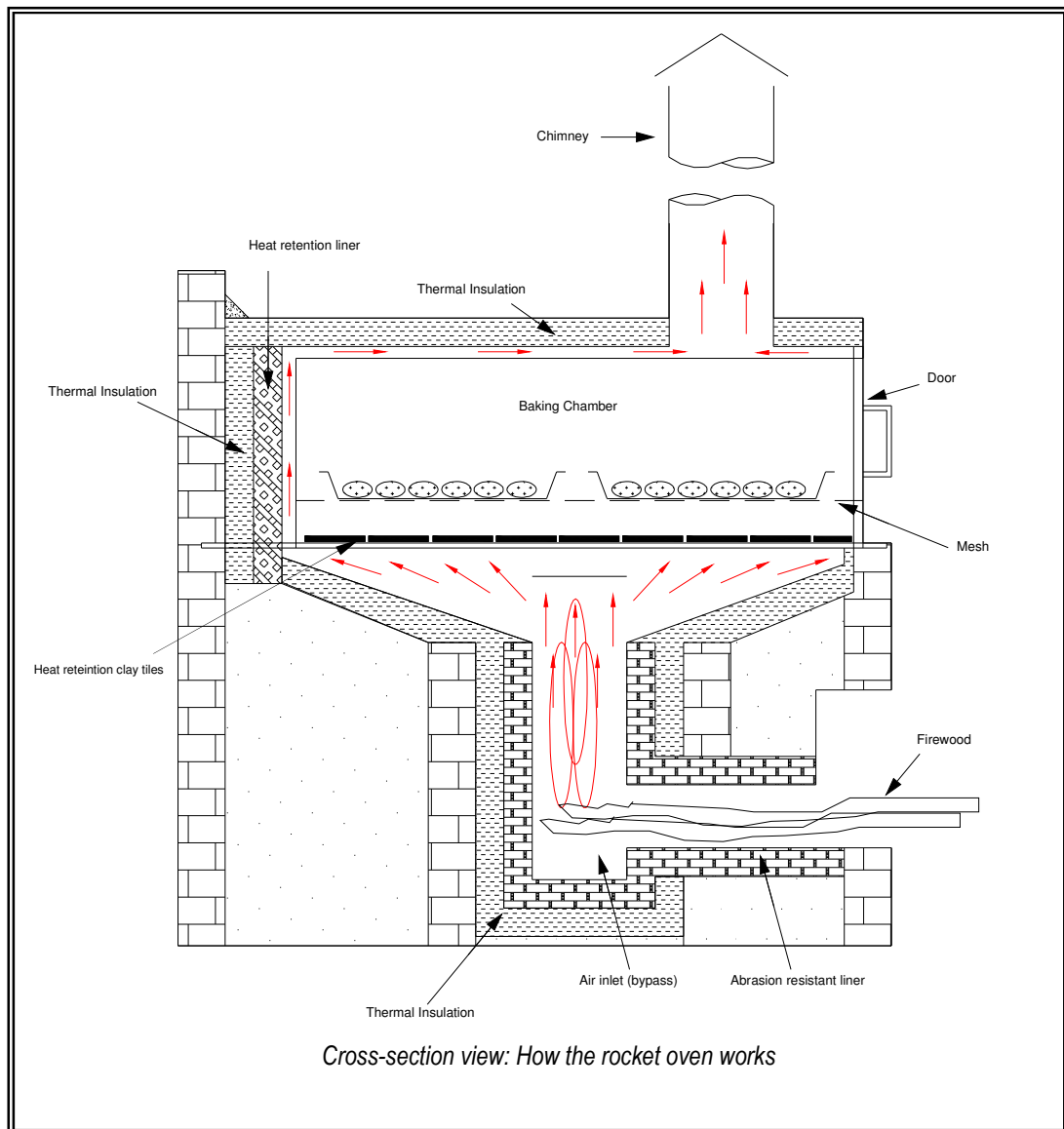

2.0 Things to Consider Before Constructing the Rocket Baking Oven

SHELTER

Ensure that shelter is in place to house and protect the baking oven from intrusion and extreme weather like rain.

TOOLS

The rocket baking oven has two major parts: -

- i. The brickwork
- ii. The metallic baking chamber

The common building construction tools are required for the brickwork while metal fabrication tools are required for the metal box (baking chamber)

Table 1: Common building construction tools for the brick work

	Brickwork tools	Purpose
1	Hoe	Digging foundation base and mixing ingredients
2	Pickaxe	Digging foundation base
3	Shovel or Spade	Extract soil from foundation base and mixing ingredients
4	Jerry can	Fetching water
5	Sieve	Sifting ingredients
6	Trough (<i>karaayi</i>)	Measuring materials by volume and carrying mixtures
7	Trowel	Placing mortar and smoothing plaster
8	Measuring Tape	Taking measurements
9	Spirit level	Inspecting horizontal level for laid bricks
10	Plumb line	Inspecting vertical alignment for laid bricks / walls
11	Try Square	Inspecting right angled corners
12	Building line	Inspecting the level of brick layers
13	Wooden float	Smoothing plaster
14	Claw Hammer	Driving and removal of nails
15	Sledge Hammer	Driving foundation pegs into the ground
16	Wall Chisel	Split, cut into, notch bricks and walls
17	Bow Saw	Cutting pumice into regular shaped blocks

Table 2: Common metal fabrication tools required for the metal box chamber

	Metal fabrication tools	Purpose
1	Hacksaw	Cutting sections to length
2	Vice	Holding sections when being cut to length
3	Hammer	Driving chisel, removal of slag
4	Chisel	Cutting metal sheet
5	File	Smoothing metal edges
6	Measuring Tape	Taking measurements
7	Try Square	Inspecting right angled corners
8	Anvil (or equivalent)	Base for hammering
9	Arc welding set	Joining metal pieces
10	Pick hammer	Removes slag from welded metal parts

Table 3: Safety Gear² recommended for use where available

	Device	Purpose
1	Eye Shield	Protection of eyes against radiation during welding
2	Leather gloves	Protection of hands from fire during welding
3	Leather apron	Protection of body and clothes during welding
4	Nose Mask	Protection against inhaling of toxic during welding
5	Industrial boots	Protection of during welding
6	Helmet	Protection of head
7	Overalls	Protection of clothes during work
8	First Aid Kit ³	Treatment for injuries

² Recommended for use where available.

³ Professional workshop practice recommends that a First Aid kit should be in place.

PART 1

SINGLE DECK ROCKET BAKING OVEN

3.0 Oven Construction Materials

This oven has a capacity of baking 28 loaves of bread of 1kg each*

3.1 Brickwork

Table 4: Brickwork specifications and quantity for the single deck rocket oven

	ITEM	SPECIFICATION	QUANTITY
Brick Structure			
1	Bricks	12 X 12 X 22 cm, Kiln Fired	800
2	Sand	River / Plaster Sand	1 Trip (1ton)
3	Cement	Portland	6 Bags
4	Water		30 Jerry cans (20l each)
Heat Insulation & Ceramics			
1	Pumice	Porous	4 bags (@ 100l)
2	Grog	High temperature	4 bags
3	Vermiculite	Exfoliated	4 Bags (@100l)
4	Clay Tiles	5" X 10 " X 1" kiln fired	70 Pcs
5	Quarry tile	8" x 12" x 1.5"	20 Pcs

* Suitable for small and medium scale baking.

3.2 Metal Oven Box Fabrication

Table 5: Requirements for metal fabrication in specification and quantity (Single deck oven)

	ITEM	SPECIFICATION	QUANTITY
1	M.S. Plate	4' X 8' X mm (1220 X 2440 X 4 mm)	1 Pc
2	M.S. Plate	4' X 8' X 2 mm (1220 X 2440 X 2 mm)	1 Pc
3	M.S Plate for oven door	4' x 8' X 0.8mm (1220 X 2440 X 1.2 mm)	1 Plate
4	M.S. Plate	15'' x 15'' x 8mm	1 Plate
5	Angle bar	1 ½ " X 20' X 6 mm (40 X 6000 X 6 mm)	2 Pcs
6	Hollow Sections	Sq. 2.5 cm X 2 mm	3 Pcs
7	Hinges (for oven door)	Bullet	1 Pair
8	Firewood grate	Steel Fabricated	1 Pc
9	Welding rods (1 pack)	G.10	1 Packet
10	Wire mesh	Sq. 6 cm (Size 118 X 118 cm)	1
11	Flat sections	50 x 6000 x 4mm	1

4. Materials Purchase and delivery

Purchase the oven brick work construction materials and deliver them to the store at the oven construction site.

Caution:

1. Materials like vermiculite, pumice, cement, and wall tiles are expensive and should be stored in a secure room.
2. Cement, vermiculite, pumice should be kept in a dry place

4.1 The Firewood Rocket Oven Drawing

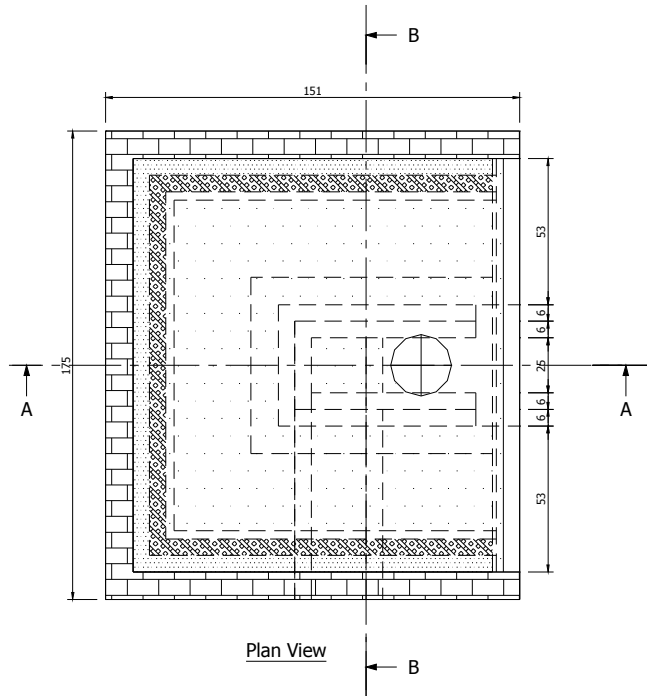

The Firewood Rocket Baking Oven

Baking Chamber: Single deck (120x120x40cm)
 Fuel: Firewood
 Dimensions: cm
 Designed by: MEMD / GTZ-PREEEP
 Drawn by: Leonard Mugerwa
 Date: November 2008

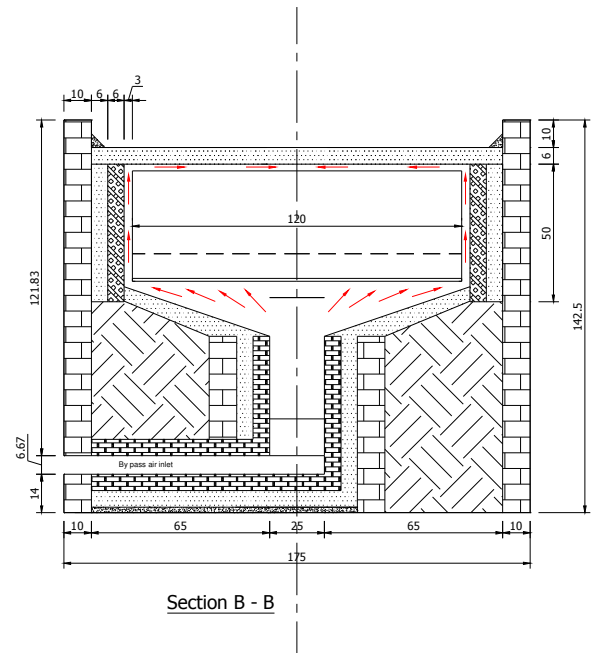
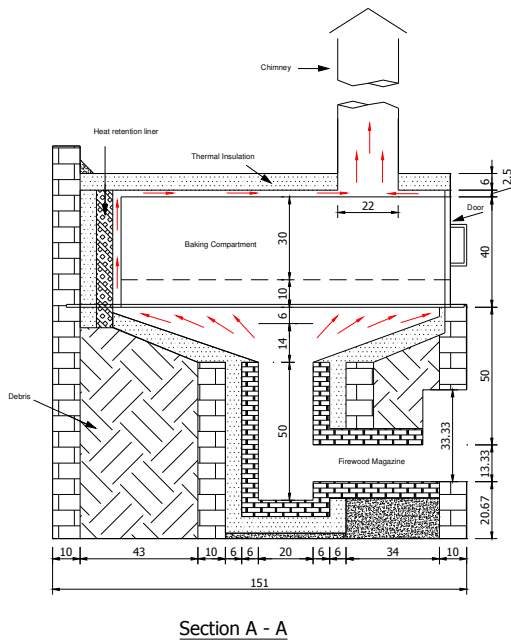
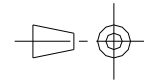

Diagram 2: Technical Drawings of the single deck Rocket Firewood baking oven

5.0 THE BRICK WORK

5.1 Determining the size of the oven base

When building a $120 \times 120 \times 40 \text{ cm}^3$ oven, its overall size will be as described in the technical drawing shown on the previous page. The reader is advised to make reference to this drawing for guidance when reading through the remaining part of this book.

The outside dimensions have not been included in the technical drawing because the sizes of the bricks that are available on the market are not the same, depending on the size of the mould that was used by the brick maker⁴. Therefore it has been preferred to specify the inside dimensions of the oven while the outer dimensions will depend on the size of the bricks used.

For instance if the size of the bricks used is $10 \times 10 \times 20 \text{ cm}$, the inside and outer dimensions of the oven's foundation will be 126 and 166 cm respectively, when laid in header style.

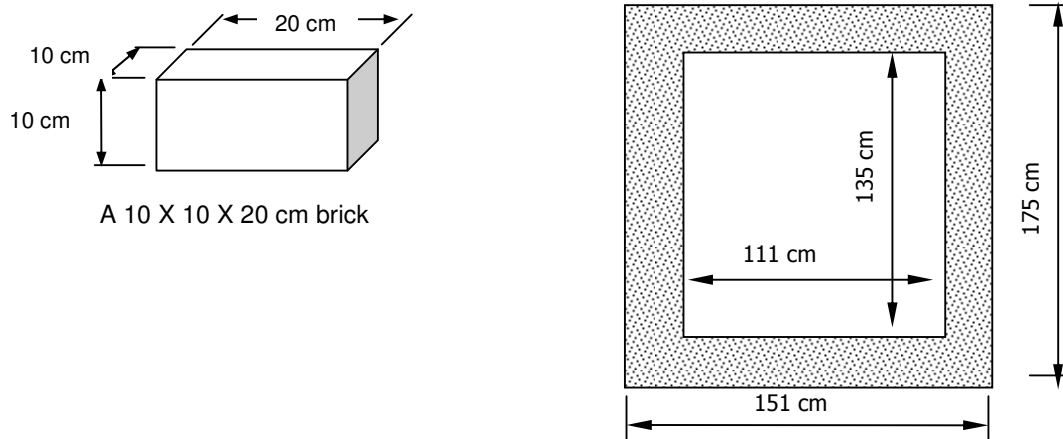

Diagram 3: Normal size of the brick and the inside and outer dimensions of the ovens foundation.

⁴ This book has been published at a time when there are no standard sizes for bricks in Uganda. Brick sizes vary according to the building construction practices or preferences of a region.

5.1.1 Determining the combustion chamber position and size

A square combustion chamber equivalent to 20cm x 20cm is used for the oven of 111cm x 135cm internal dimensions shown above.

- Draw the outline of the stove base on paper with dimensions clearly marked,
- Following these drawings, make a floor plan where the stove is to be built,
- Draw the diagonal lines across the outline and mark where they cross each other as shown in Diagram 4. This will be the centre of the oven combustion chamber.
- Measure a distance of 20cm apart between each two diagonal sides at equal distances from the centre. This will give you a smaller square (20cm x 20cm) in the middle forming the combustion position of the oven.
- Draw lines outwards of the central box in perpendicular direction to form
 - a) Fuel Magazine
 - b) By pass Air inlet

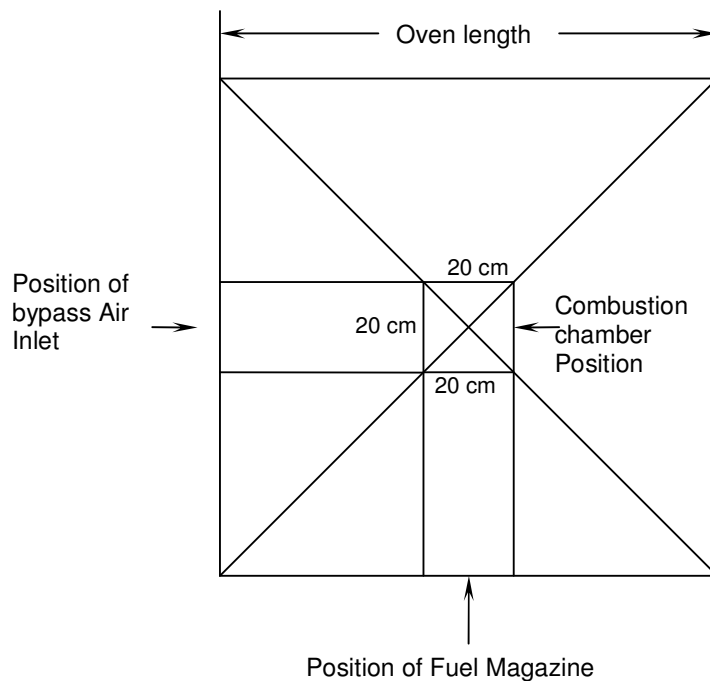

Diagram 4: Positioning the fuel magazine and Bypass air inlet

5.2 Following diagrams 3 and 4 above, map the foundation base on the ground and use wooden pegs to fasten building lines to aid the excavation as shown in figure 1.

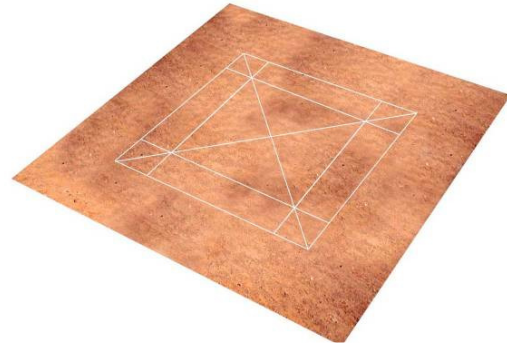

Fig. 1

5.3 Use the pickaxe and hoe to dig the foundation base within the bounds of the building lines.

Use a spade to remove the soil from the foundation base. In the centre marked as in diagram 3, dig a depth of approximately 10cm as shown in figure 2

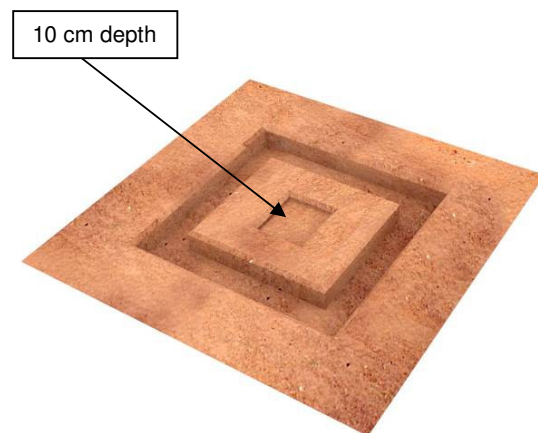

Fig. 2

5.4 Mix the cement and sand in a volumetric ratio 1:3. Add water and blend the mortar as shown in picture 1.

Also mix insulation fire resistant mortar of cement and grog in a volumetric ratio 1:2. with water.



Picture 1

5.5 Lay insulative pumice blocks at the centre as shown in the figure 3. Bond and Cover the pumice blocks with fire resistant mortar to form a smooth surface. Concurrently, lay the foundation bricks in a header style as shown after placing a layer of mortar below.

The mortar should also be placed between the bricks for effective bonding just as it is usually done in building construction.

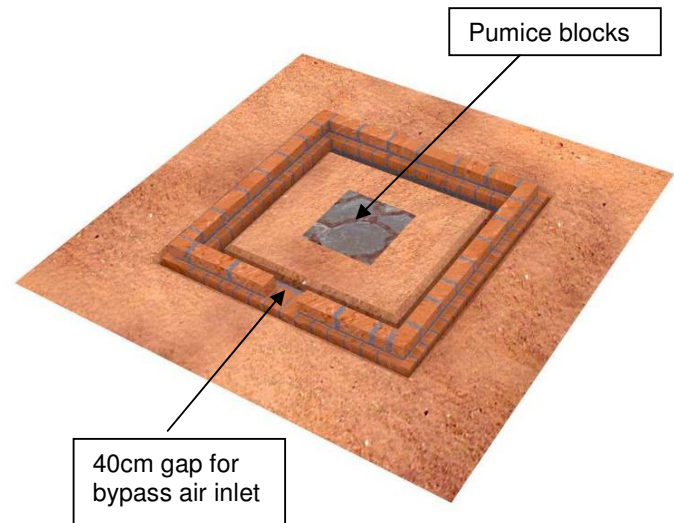

Fig. 3

After constructing at least 2 layers of bricks for the foundation, in the header style depending on the strength of the ground, start to build the walls of the oven.

The bricks forming the walls may be laid in the stretcher style as shown in figure 3.

Leave a 40 cm gap for the bypass air inlet centred on one of the walls as shown in figure 3.

5.6 Calculating the combustion chamber height.

Considering the rocket principle, and the early text. The overall open end height of the firewood magazine is J .

- For this oven size:
 $J = 20$ cm.
- This then means the air inlet is $J / 3 = 20/3 = 6.7$ cm.
- The actual firewood magazine will be $2J/3$ as illustrated in the diagram implying,
- $2J/3 = 40/3 = 13.3$ cm
- $K = 1.5 \times J = 1.5 \times 20 = 30$ cm
- The overall Height (H) of the Combustion chamber is
 $H = K + J = 30+20 = 50$ cm

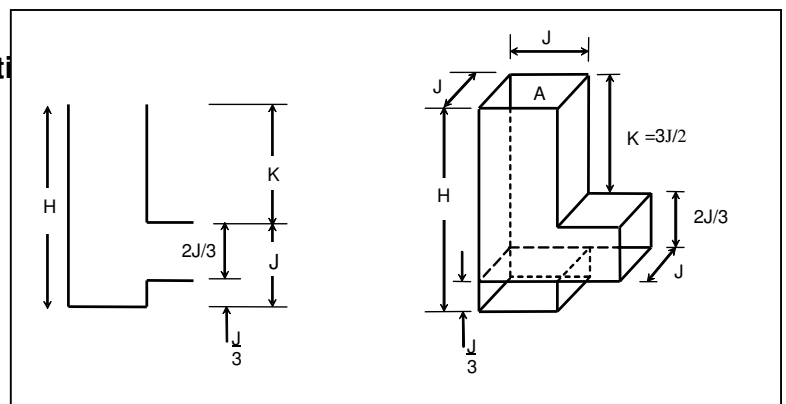

Diagram 5: Details of the combustion chamber dimensions.

5.7 Using fire resistant mortar and special firebricks/ clay liners, lay the combustion chamber foundation as shown. Providing for the bypass air inlet and firewood magazine.

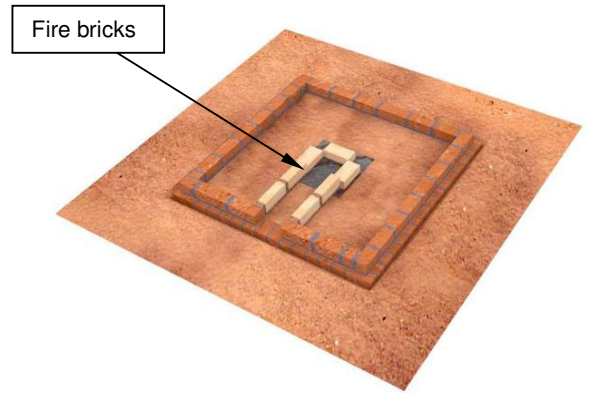

Fig. 4 Foundation for firewood magazine

Simultaneously build a foundation for the firewood inlet in a perpendicular direction beginning from the centre outwards using firebricks. Also using ordinary bricks build a reinforcement wall directly opposite the firewood inlet as illustrated in fig. 5

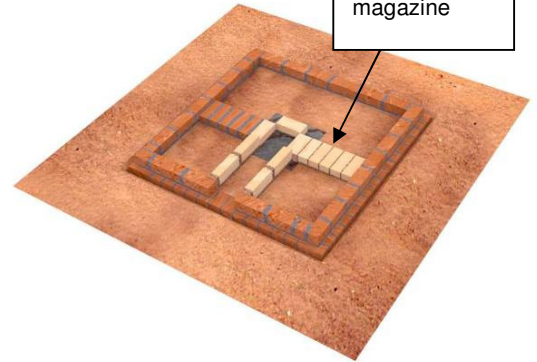

Fig. 5



Metallic grate

5.8 In the centre and at a height 6.7 cm from the ground level, insert the metallic grate such that it is supported by fire bricks as shown in figure 6.

This metallic grate is rectangular shaped in order to enable it to rest on a square shaped combustion chamber base.

All the joints in the firebricks must be filled with fire resistant cement grog mixture.

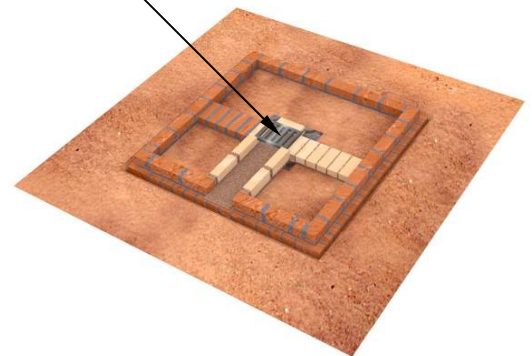
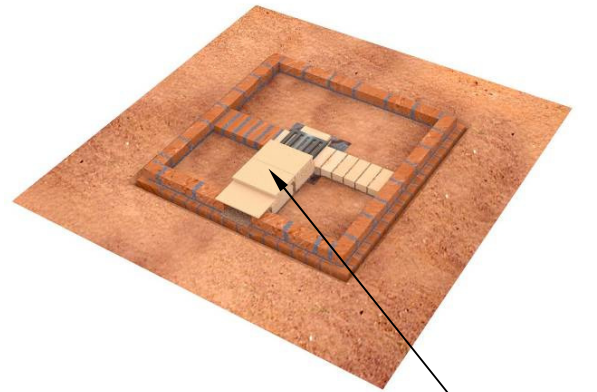

Fig. 6

5.9 After inserting the grate, construct an arc using quarry tiles over the bypass air inlet.

This level forms the base of the firewood inlet at an elevation of 6.7cm above the ground as shown in fig 7.



Arc constructed with quarry tiles

Fig. 7

5.10 Continue constructing the walls of the combustion chamber. At the firewood grate level, construct a tunnel like structure of height 13.3 cm in the direction of the firewood inlet and insert quarry tiles to form an arc as shown in figures 8 and 9. This will be the firewood inlet.

Use a tri-square, plumb-ball spirit level, to inspect right angles and brick levels in the combustion chamber and external walls

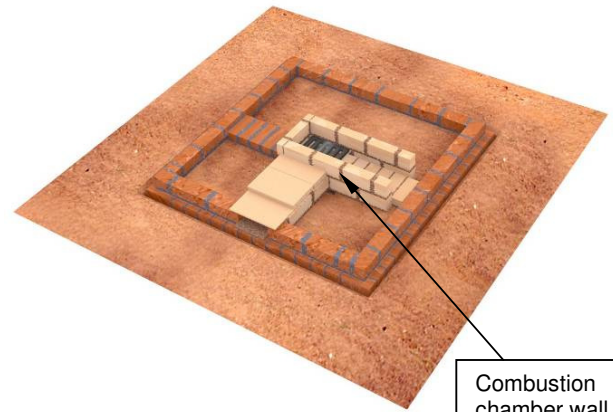

Combustion chamber wall

Fig. 8

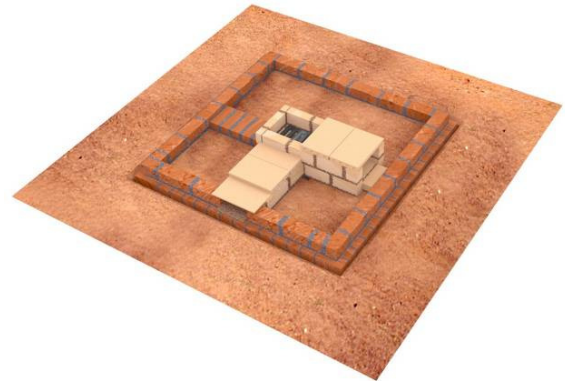

Fig. 9

5.11 Proceed by raising the square combustion chamber walls to the recommended height of 50cm. Use a mixture of grog and cement in ratio 2:1 respectively with fire bricks.

This mixture is made using water.

5.12 Concurrently, continue to build the combustion chamber support walls using ordinary bricks and mortar leaving a 6-7 cm insulative gap to be filled with pumice as shown the figure 11.

Use the try square to ensure that walls are right angled at the corners. Use the building line and spirit level to ensure that bricks in each layer are at the same horizontal level.

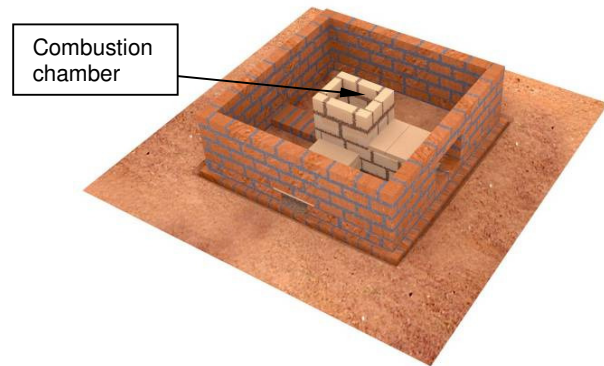

Fig. 10

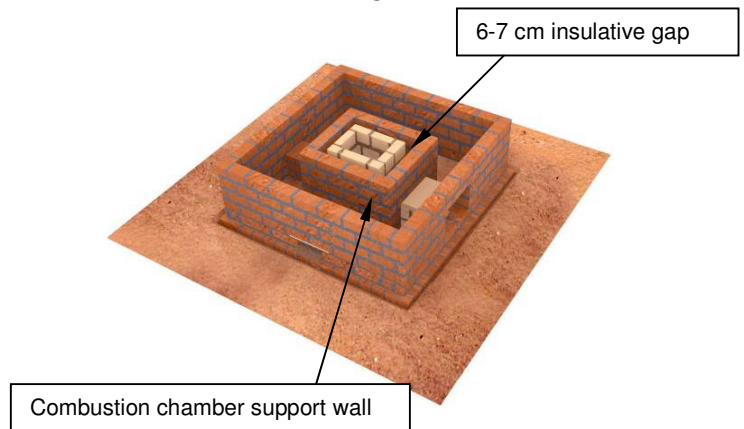

Fig. 11

5.13 Use the bow saw to cut the Pumice into several slabs each of 5-6cm (minimum thickness).

The pumice slabs will be used for thermal insulation in the gap left around the combustion chamber and around the flue gas (fire) passages. The recommended minimum thickness= 5 cm



5.14 Insert the cut pumice blocks in the gap between the combustion chamber and the support walls as shown in fig 12. This will form insulation for all the heat generated in the combustion chamber.

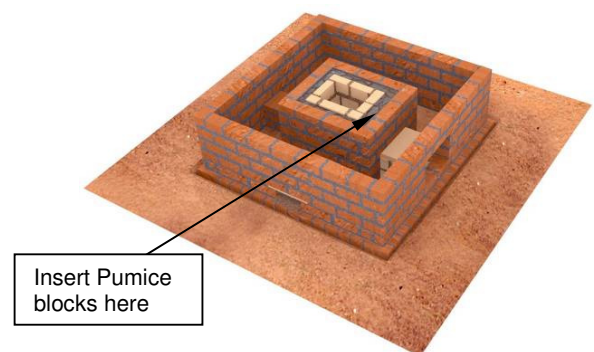

Fig 12

15.15 Fill the gap between the oven Outer walls and the combustion chamber support walls with debris.

The debris should be laid to provide a base that inclines outwards from the combustion chamber.

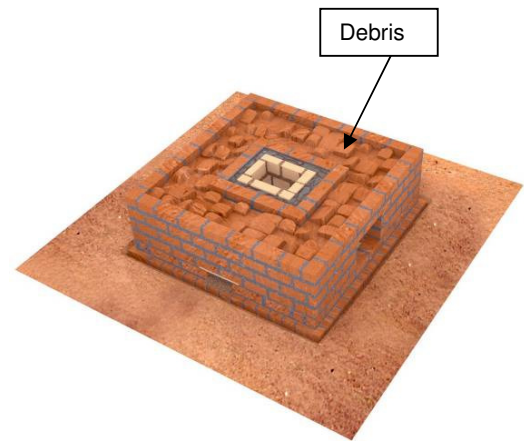

Fig 13

Continue to build the oven walls to about another 32 cm in order to give room for construction of the slanting insulation layer above the combustion chamber as shown in fig 14. Chisel 2 holes in the vertical insulation at the backside to be used to hold the metal box support angle bars.



Fig 14

5.16 Using a mixture of cement and sand place some form of slab on top of the debris to form a primary foundation for the insulation layer to be built in the next stage. The ratio of sand to cement should be 3:1. Start to shape the slant at this level in the slab.

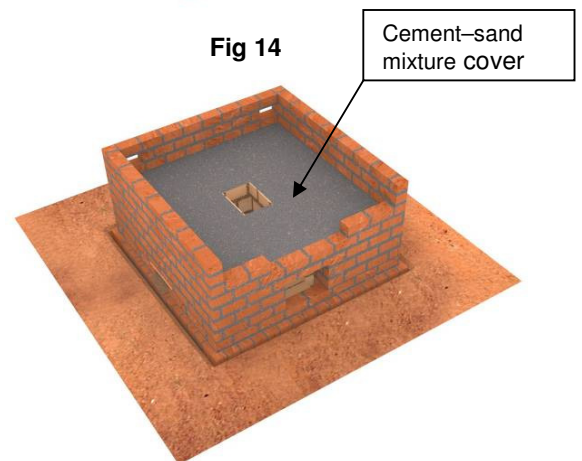

Fig 15

5.17 Erect 4 supports for the box on the sloping surfaces spaced at 80 cm.

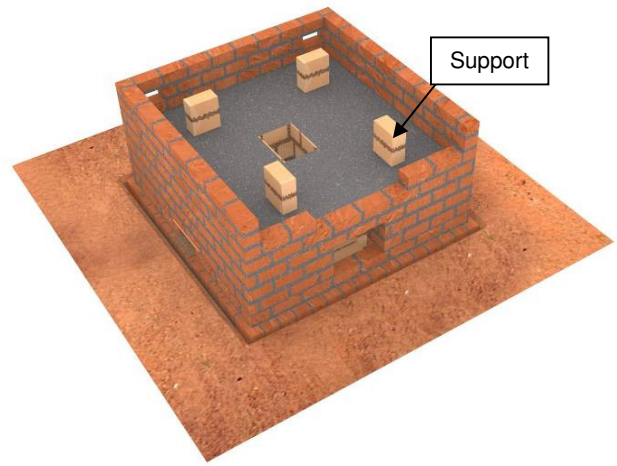

Fig 16

5.18 Lay pumice slabs horizontally along the generated slant as shown in figure 17. Use the insulation mortar to form bonding between the pumice slabs.

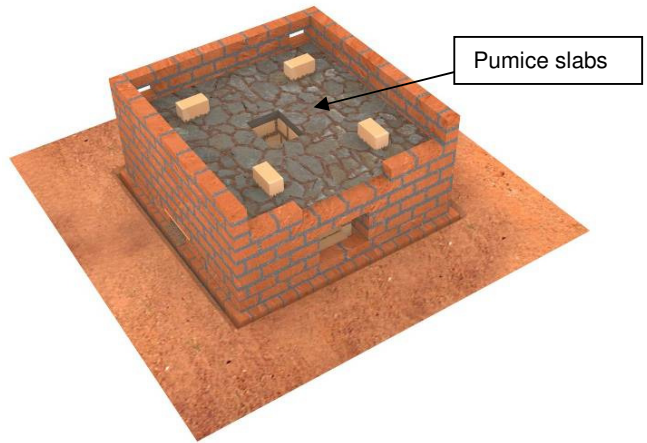

Fig 17

Use the insulation mortar to plaster and make the slope faces smooth.

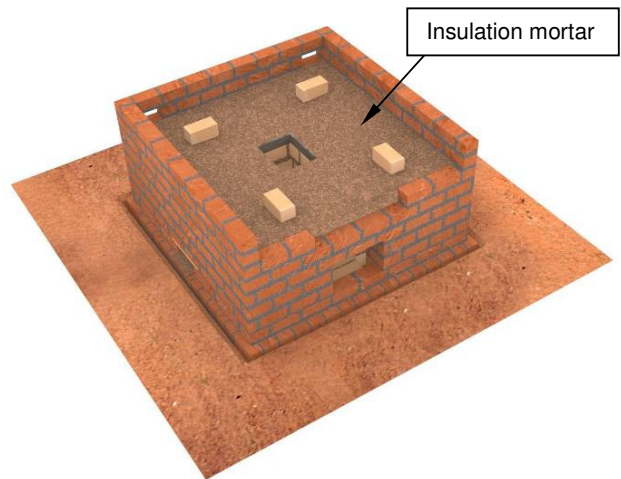

Fig 18

5.19 Continue to build the oven walls upwards to 3ft using ordinary bricks and ordinary cement and sand mixture leaving the front side open as provision for insertion of the metallic baking box as shown in figure 19.

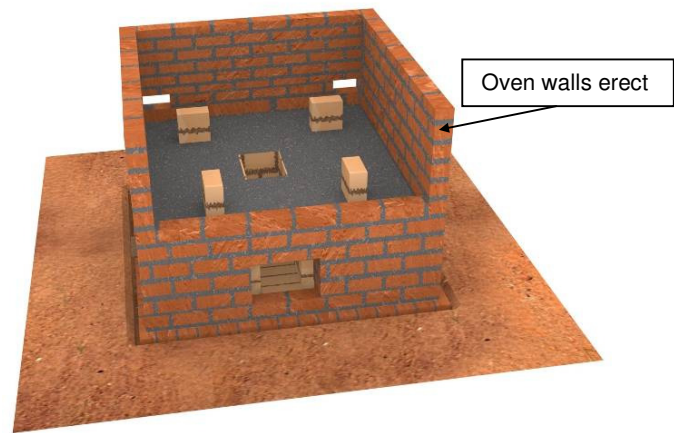

Fig 19

5.20 Using pumice slabs and insulation mortar, build the vertical insulation layer of minimum thickness 6cm. This will help to reduce heat loss through the oven walls in order to give the

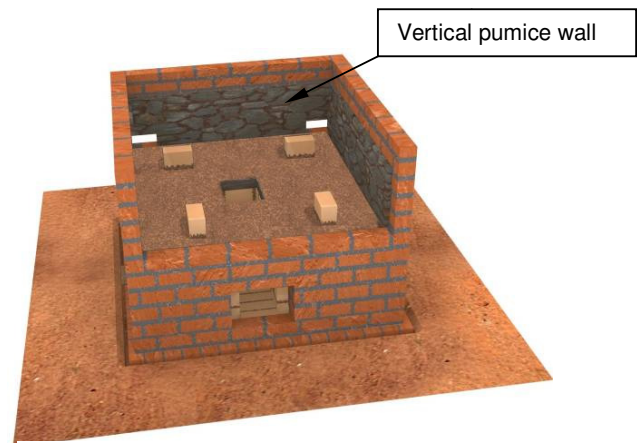

Fig 20

5.21 Construct a an insulative heat retention layer of firebricks or heat retention tiles of a approximate thickness 6cm on top of the pumice layer.

In practice this step is concurrently done with the insertion of pumice in order give support and regularity to the pumice wall.

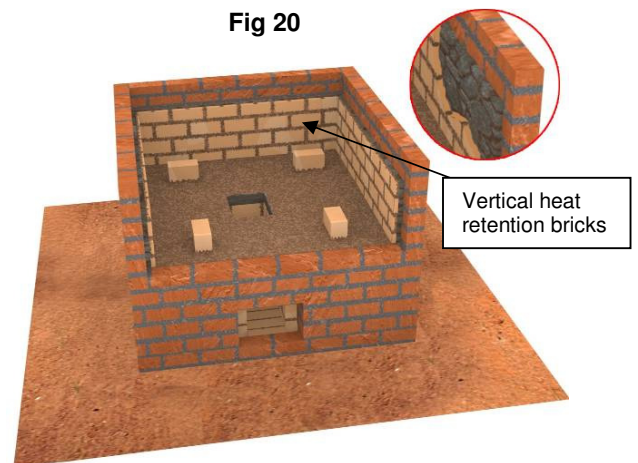

Fig 21

6.0 THE METAL BOX / BAKING CHAMBER

Single deck oven (120 x 120 x 40cm)

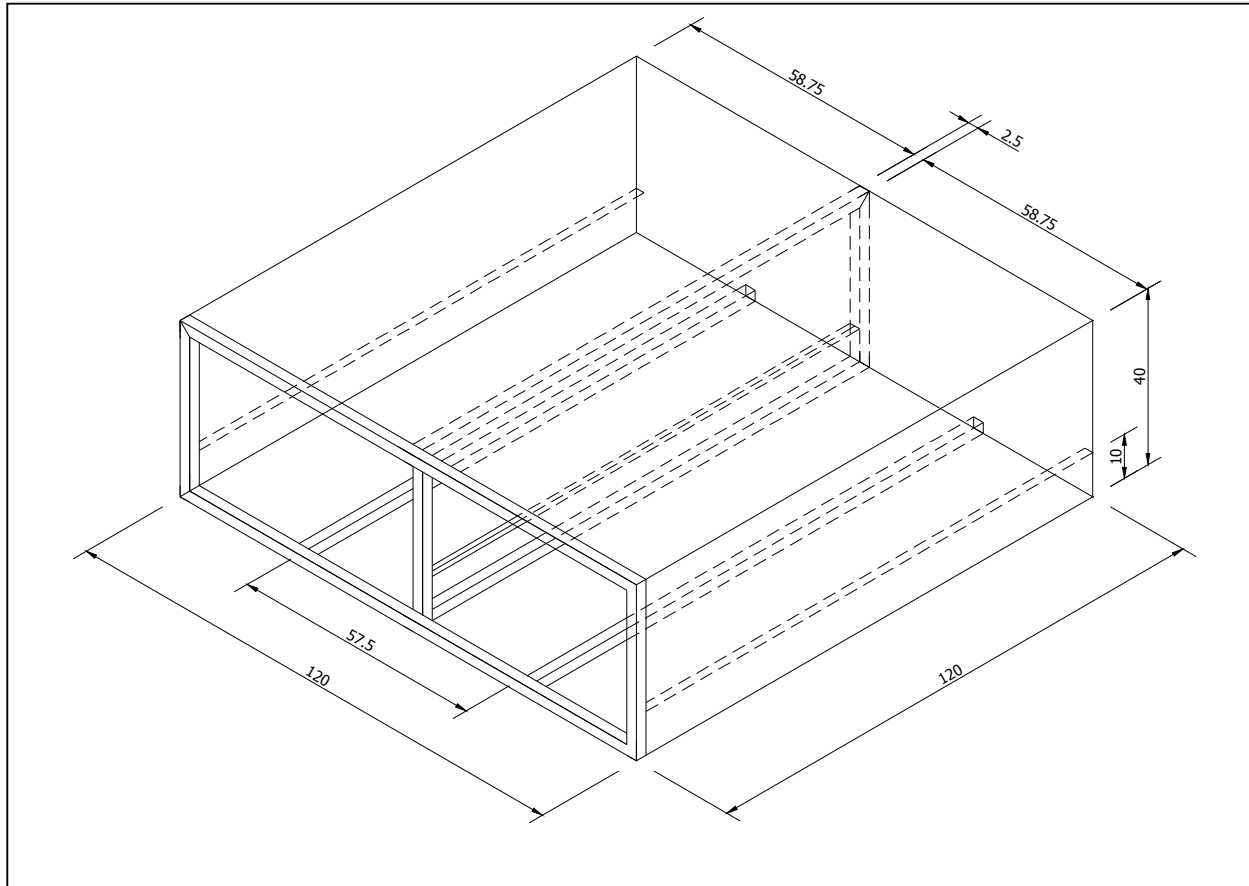

Diagram 6: Illustration of dimensions of the 120 x 120 x 40cm metal oven box

6.1 Fabrication of the metal box (baking chamber) Single Deck / 4 trays Oven (Capacity 120 X 120 X 40 cm³).

When fabricating the 120 X 120 X 40 cm³ metal baking chamber, usable for small and medium scale baking, its overall size will be as described in the technical drawing shown on the next page. The reader is advised to make reference to this drawing for guidance when reading through the fabrication procedure.

It is recommended that the bottom and sides of the box be made from the 4 mm thick mild steel (M.S.) plate in order for the oven to last long enough. This is because the fire from the rocket – elbow combustion chamber, are quite hot and can easily wear out M.S. plates of less thickness as revealed by experience at the bakeries which are currently using the oven. The top covers of the box may be fabricated out of the 2 mm thick M.S. plate because the temperature of the hot flue gases will have reduced at this point. Finally the oven bottom of the metallic box is reinforced with a secondary heat protection thick M.S. plate (8mm recommended) to prevent direct contact of the fire with the oven bottom.

Lay down the 1220 X 2440 X 4 mm M.S. plate (= 4' X 8' X 4 mm), and then mark it for cutting / bending as shown below.

KEY: Cut with hammer driven chisel / angle grinder with steel cutting disc
Soften with hammer driven chisel then bend through 90°

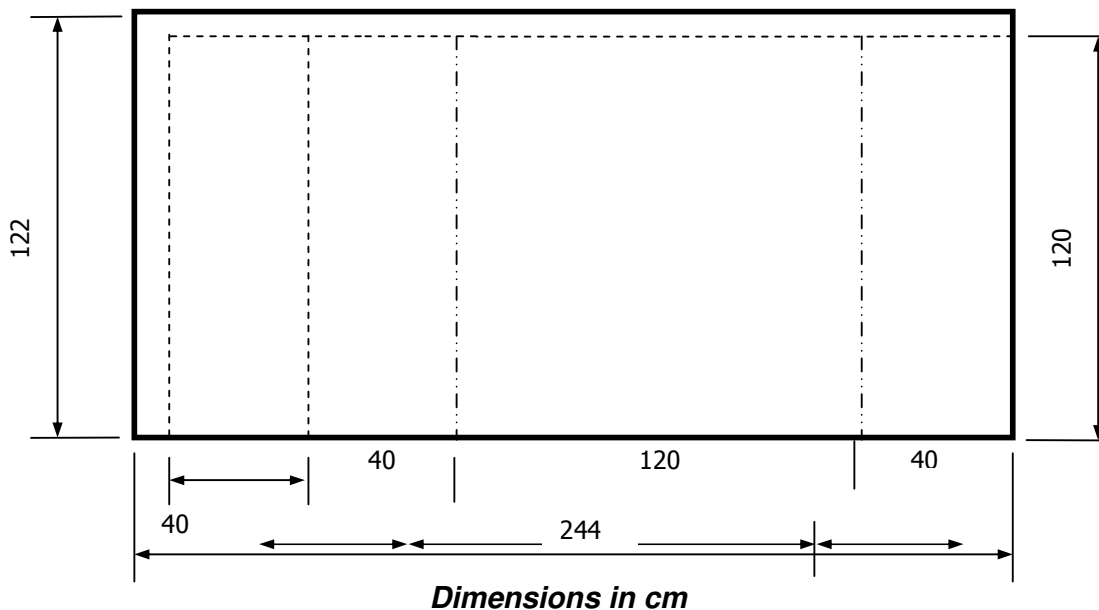

Diagram 7: Bending the 4mm metal sheet to form metal box (Baking chamber)

6.2 Bend the piece that has been cut from the M.S. plate 1220 X 2440 X 4 mm (= 4' X 8' X 4 mm) through 90° along the softened lines to obtain a U-shaped piece. Ensure that there are no holes along the bends.

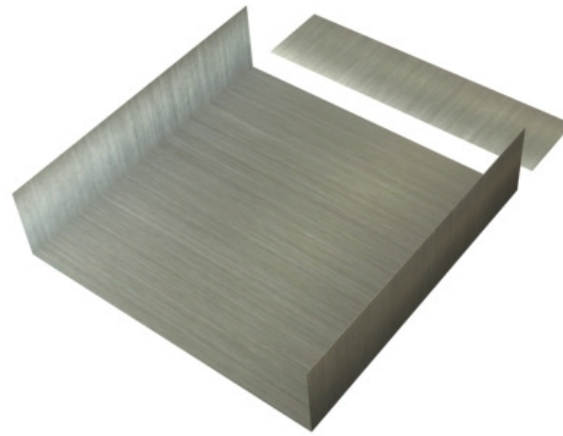

Fig 22

6.3 Use arc welding to attach the 40 X 120 cm piece that has been cut from the M.S. plate 1220 X 2440 X 4 mm (= 4' X 8' X 4 mm) to the back side of the U – shaped piece. The edges should be given a full (continuous) weld to prevent the flue gases, smoke etc, from entering the baking chamber.

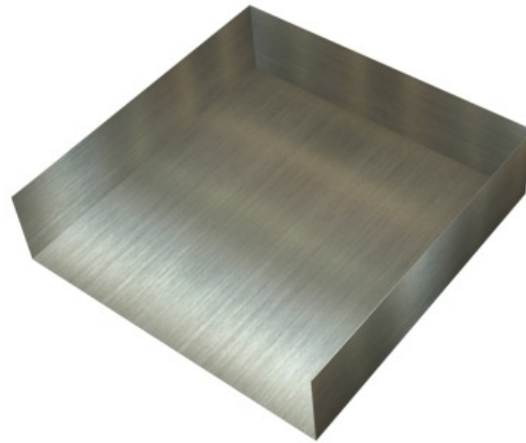

Fig 23

6.4 Lay down the 1220 x 2440 x 2mm MS plate (= 4' X 8' X 2 mm), and then mark it for cutting as shown below.

KEY: ----- Cut with hammer driven chisel / angle grinder with steel cutting disc.

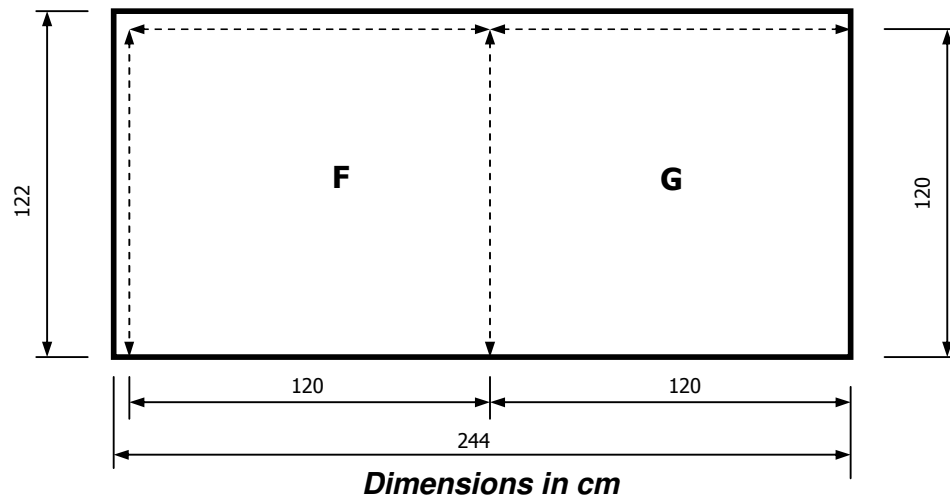
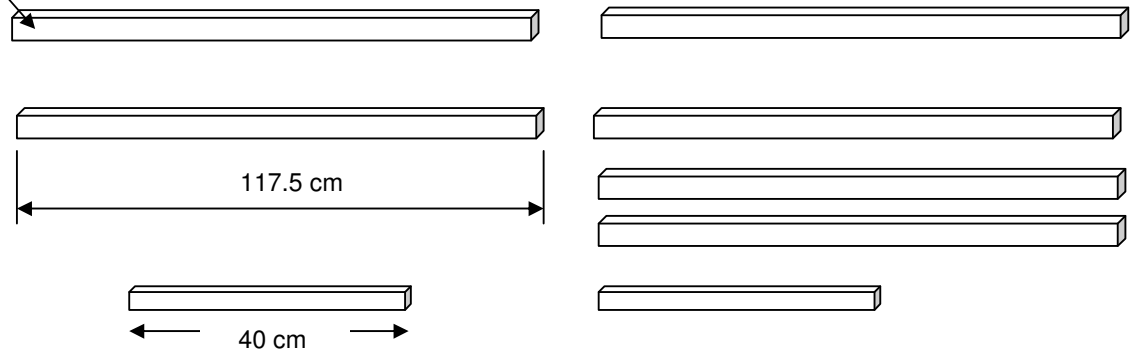

Diagram 8: Cutting the 2mm MS plate for the metal box top

6.5 Cut a hollow section (sq. 20 X 6000 X 2 mm) into segments of 117.5 cm length each.

Hollow section
Sq. 25 X 2 mm thick



6.6 Assemble some of the segments to form internal support frame of the oven box as illustrated. This will give vertical support in the middle of the oven baking chamber to check sagging when the oven gets hot during baking.

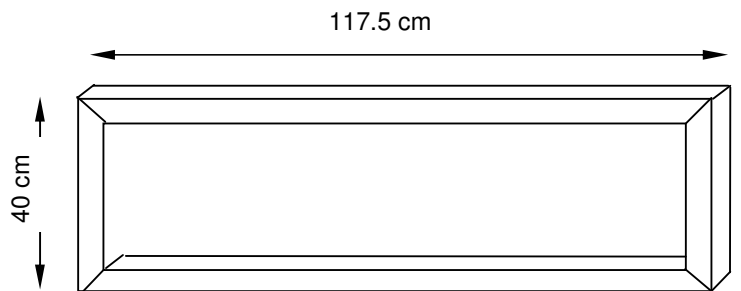

6.7 Weld two 117.5 cm hollow section segments on the M.S. plate assembly, as shown, to increase its structural strength. Spacing is 57.5 cm. (Also refer to the metal box drawing in diagram 6). Position them starting from the back while leaving a 2.5 cm gap towards the front of the box.

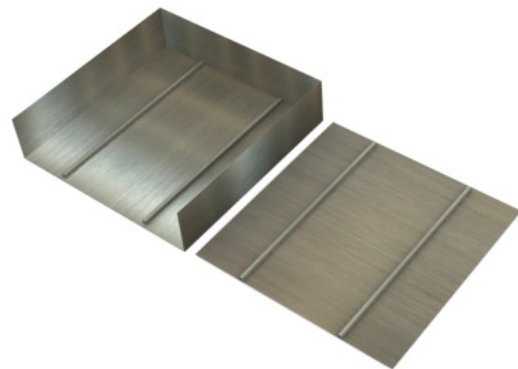

Fig 24

6.8 Insert the complete support frame vertically and weld it in the middle of the MS plate assembly as illustrated. Use a pick hammer to remove the slug from the welded joints

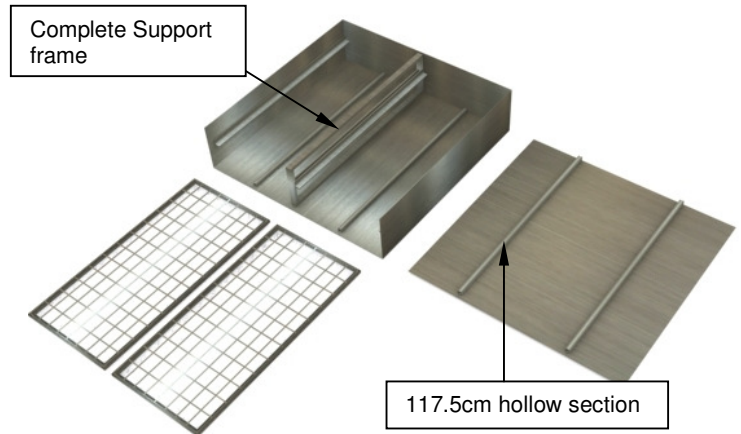

Fig 25

6.9 Weld the remaining 2 pieces of the 117.5 cm hollow section segments on one of the sheets (say **F**) cut from the 2 mm M.S. plate, as shown, to increase its structural strength. Spacing is 57.5 cm. (Also refer to the metal box drawing diagram 6). Position them starting from the back while leaving 2.5 cm gap towards the front of the sheet. See figure 25.

6.10 Invert the 2 mm M.S. sheet that has been welded with the hollow sections to form the top cover for the box and weld it at the edges to form the box as illustrated in fig 25. Ensure that the edges of the box are fully welded to make them airtight. This is important in preventing flue gases, smoke etc from entering the baking chamber during baking. The result is that baking products (bread, cakes etc) will be clean.



Fig 26

6.11 With the edges at an angle of 45°, cut the hollow section (sq. 25 X 6000 X 2 mm) into segments of the lengths specified below. These will be used to make the door shutter.

2 segments of 119.4 cm

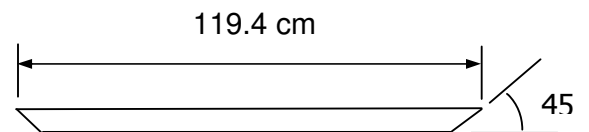

2 segments of 39.5 cm

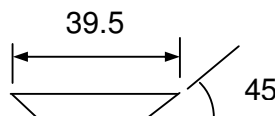

6.12 From the same section as above, cut one segment with flat edges and length 35 cm which will act as support in the middle of the door shutter.

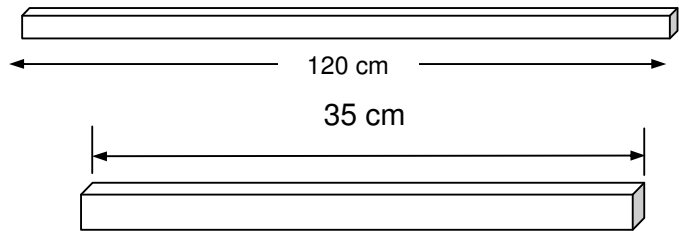

6.24 Weld the 45° angled hollow sections into a rectangular frame together with the central support section. This will be the door shutter for the baking chamber.

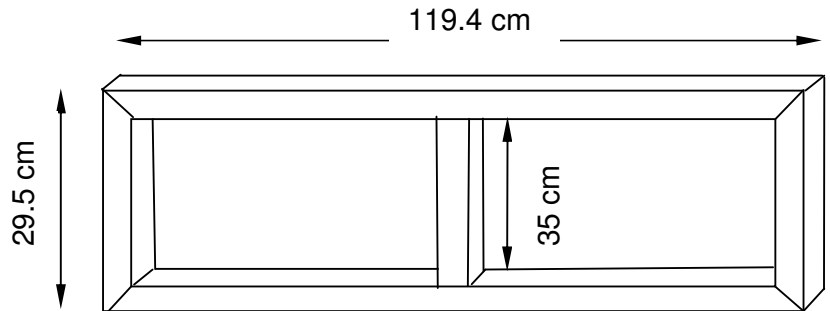

Weld the rectangular doorframe to the entrance of the metal box as shown in figure 27.

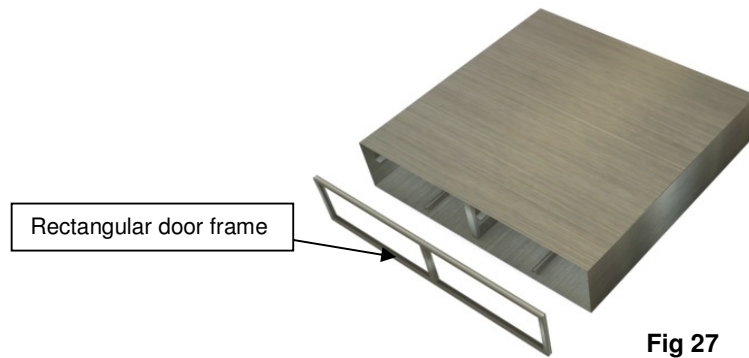

6.25 Lay down the 122 cm X 244 cm X 0.8 mm thick M.S. plate. Mark it for cutting as shown. Cut it and label the pieces with letters respectively

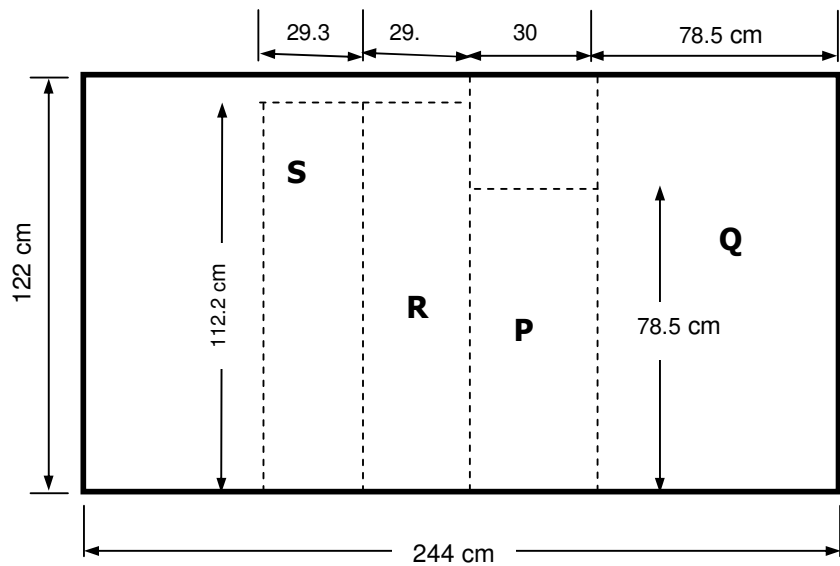

6.26 Cut out segment **R** and divide it into 2 pieces of equal length i.e. 56.1cm.

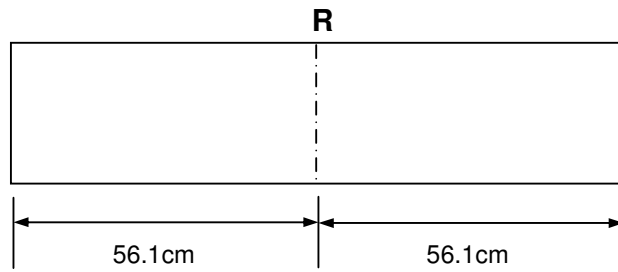

Cut out 1.5 cm squares from the corners of each of the two metal sheets marked from **R**.

Mark the dotted lines on the remaining piece of the two sheets as shown.

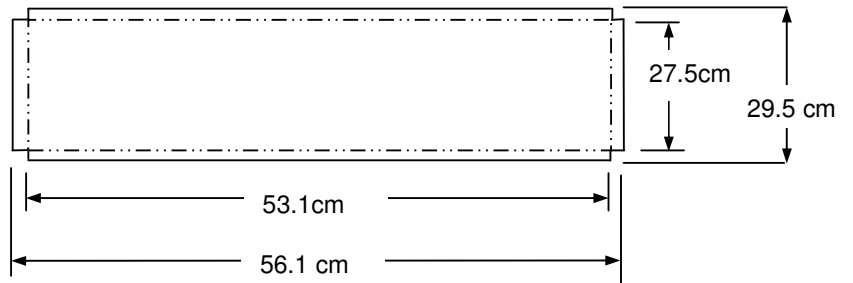

Fold them along the dotted lines through 90° to form two tray – shaped pieces.

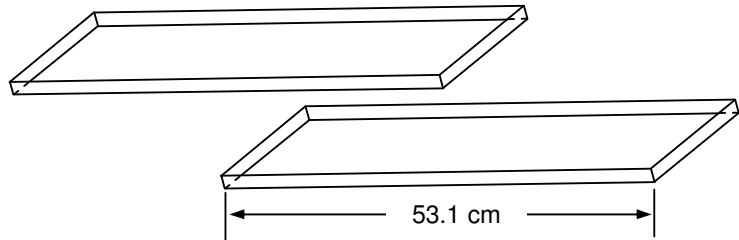

6.27 With the edges at an angle of 45°, cut the hollow section (sq. 25 X 6000 X 2 mm) into segments of the lengths specified below. These will be used to make the 2 door frames

4 segments of 54.5 cm

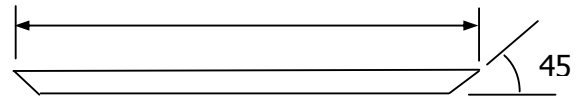

4 segments of 29.5 cm



6.28 Weld the 45° angled hollow sections into two rectangular frames. These will be the door shutters for the baking chamber

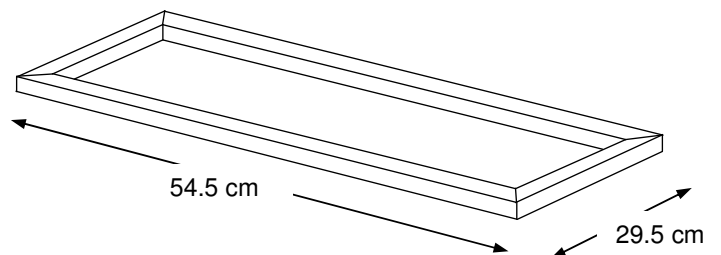

6.29 Use arc Weld to fit the tray – shaped pieces into the door shutter frame. It will then appear like a tray bounded by a hollow section frame.

Fig 28

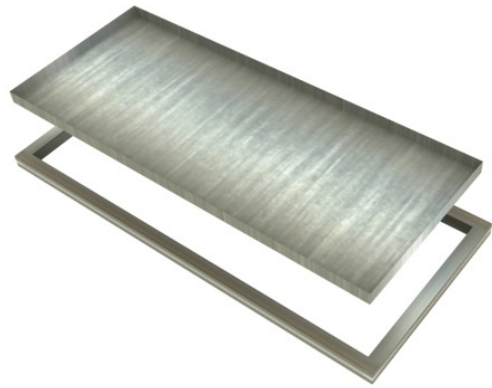

6.30 Fill the tray – shaped piece with vermiculite to level.

Cover it with metal sheet **S** and use arc welding to fix it onto the frame.

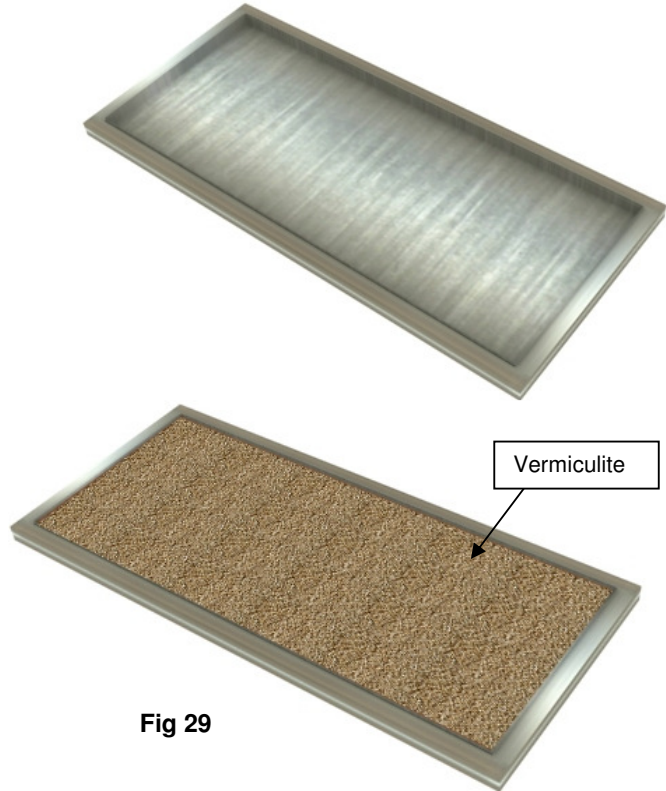

Fig 29

6.31 Cover it with metal sheet **S** and use arc welding to fix it onto the frame.

Ensure that the weld is continuous (full) such that the vermiculite does not pour out through the door shutter.

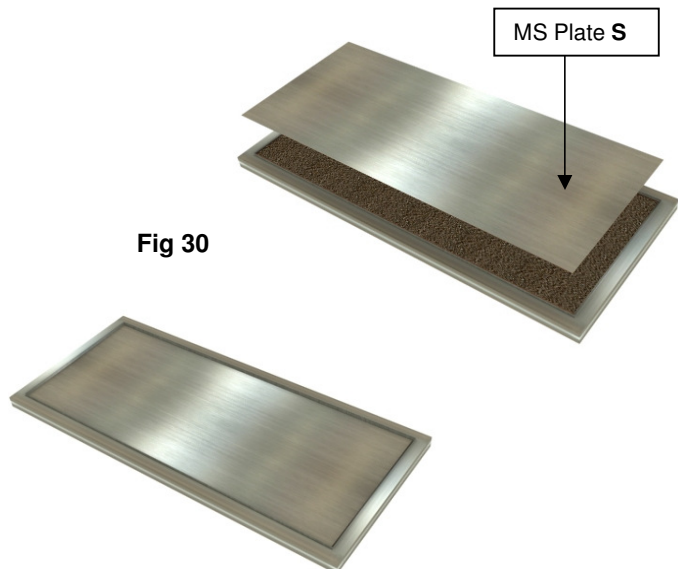

Fig 30

6.32 Fit hinges to the sides of the door shutter and use arc welding to fit to the box such that the doors open sideways.

Fit a latch and a handle to the door shutter. Both of them should be insulated to protect the oven user from injury.

At this stage the box appears as shown in figure 32.

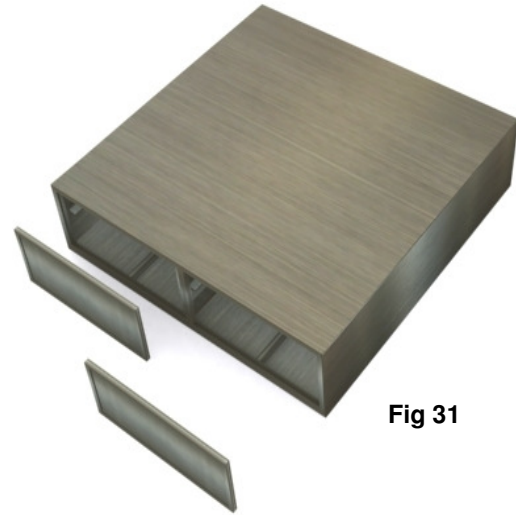

Fig 31

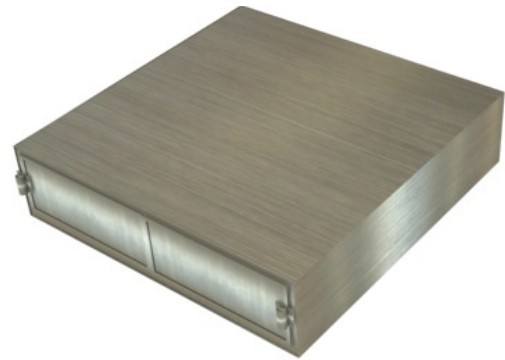
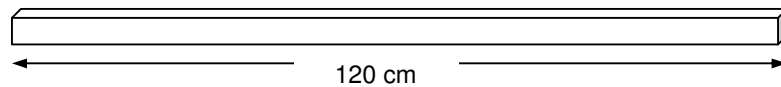

Fig 32

6.33 Cut more of the hollow section (sq. 30mm X 6000 X 2 mm) into segments of

One segment of 120 cm each



One segment of 70 cm each

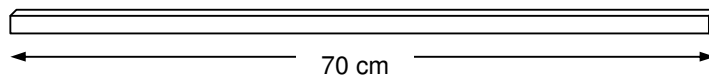

2 segments of 59 cm each

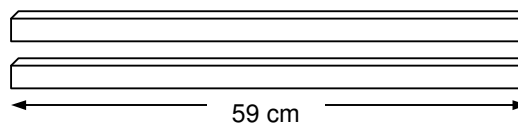

2 segments of 91 cm each



2 segments
of 38 cm each

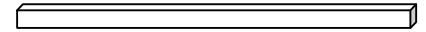
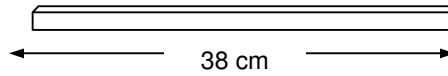

2 segments
of 51 cm each

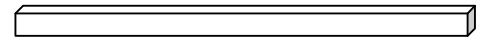
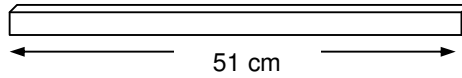

2 segments of
45 cm each

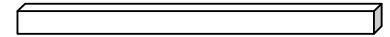
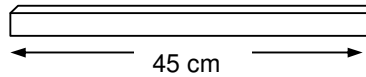

2 segments of
48 cm each

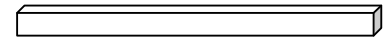
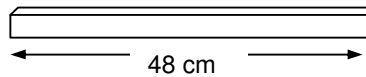

1 segments of
10 cm each

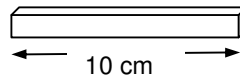

6.34 Position the hollow section segments radially on the top face of the box as shown below. The picture shows the plan view of the box when facing in the direction of the arrow marked F.E. (see Diagram 9). Use arc weld to fix them into position.

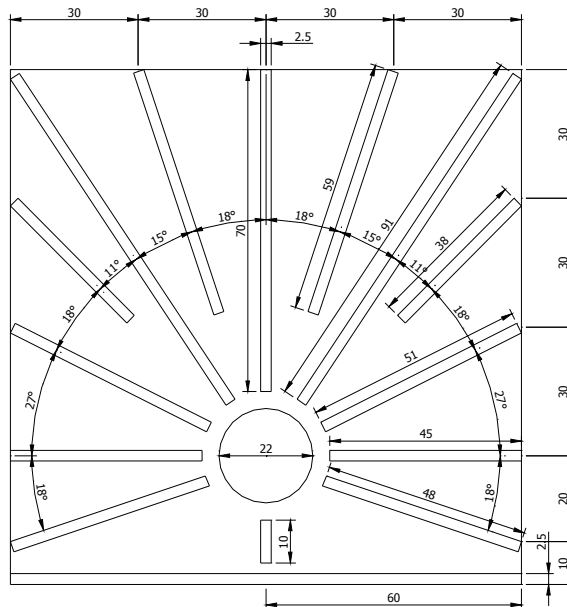

Diagram 9: Oven top fire distribution pattern

Key

M represents the position to be occupied by the chimney; centred on the top of the box.



Fig 33

Constructing the Oven top cover

6.35 Lay down a fresh MS Plate of 122cm x 244cm x 2mm and mark it for cutting as shown. Label the sheets **G** and **H** as shown in the diagram.

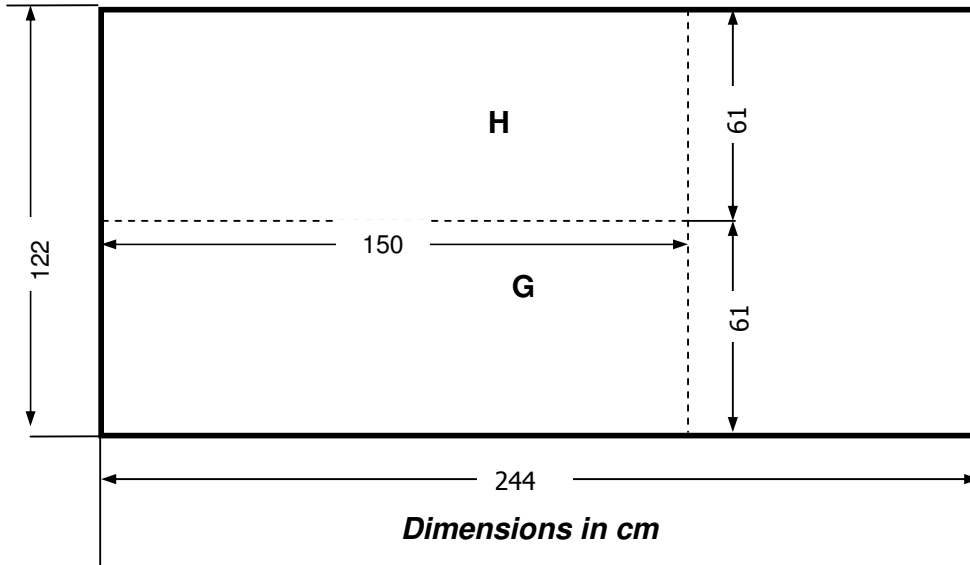

6.36 Lay down 2 angle bar sections measuring 40 x 4mm x 6m and cut them into 4 segments of 150 cm length and 4 segments of 61 cm length.

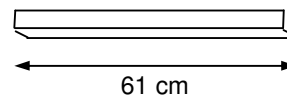
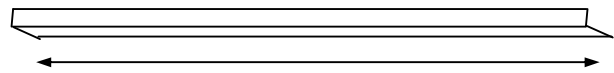

Weld the angle sections to form two rectangular frames of sides 150 x 61 cm.

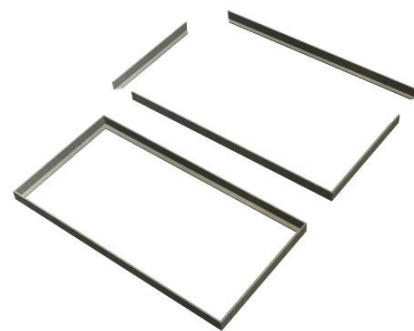

Fig 34

Lay down and weld the MS Plates **G** and **H** in to the frames in figure 27.

6.37 Scribe a 25 cm diameter circle at the centre of one of the Plates named **G** as shown in figure 28.

Use a chisel driven hammer to cut along the perimeter of the circle to form a hole to be occupied by the chimney

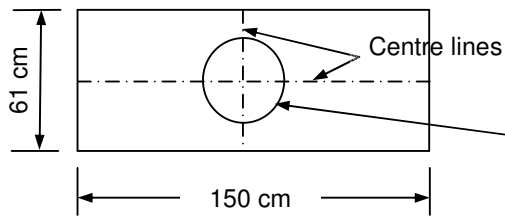
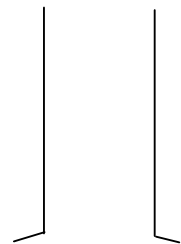
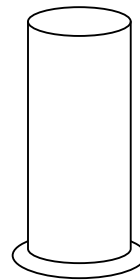
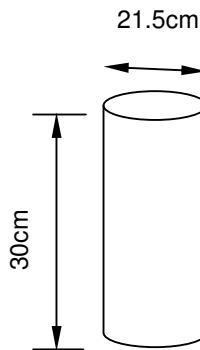

Fig 35

Dia = 22cm

6.38 Making use of the M.S. Plate 122 cm X 244 cm X 0.8 mm Labeled in 6.25, roll the sheet marked **P** to form a cylinder. Use seaming to join the edges. Taper it at the top.



6.39 Use the hammer and anvil to spread out the shape of the base. This forms the chimney base.

6.40 Insert the chimney base into the 25 cm hole in the centre of the 2 mm M.S. sheet (sheet **G**). Insert it from below as shown.

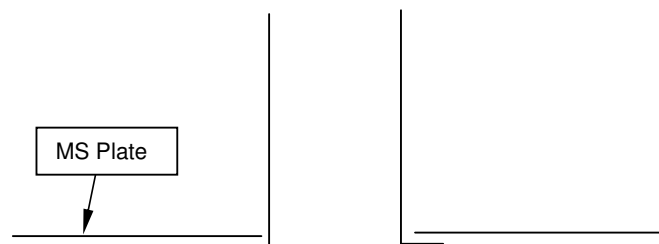

Note:

For purposes of clarity, the gaps in the diagram have been made to appear bigger.

6.41 Use arc weld to fit the chimney base to the 2 mm M.S. sheet (sheet G) as shown.

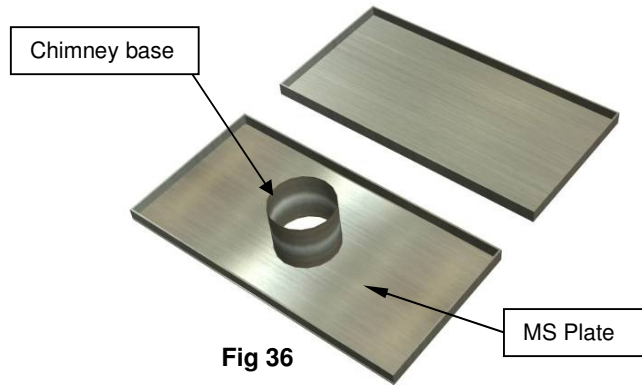

6.42 Fill the top covers with vermiculite as shown. This will help in insulation of the oven top in order to allow for sufficient movement of heat around the box before the hot smoke finally escapes through the chimney pipe.

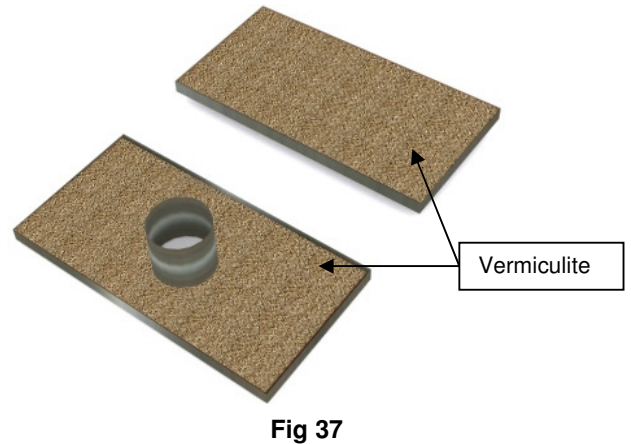

6.43 Repeat step 6.13 and 6.14 to obtain two other M.S. Plates for use to cover the vermiculite in figure 37. Use arc weld to seal these tops in order to prevent any leakages.

6.44 These will be placed on the radial hollow segments on top of the box assembly.

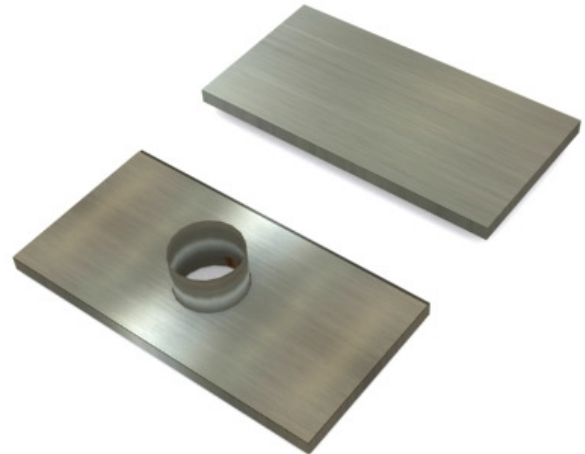

6.45 Lay down an angle bar measuring 25 x 40mm x 6m and cut it into 2 segments of 150 cm length.

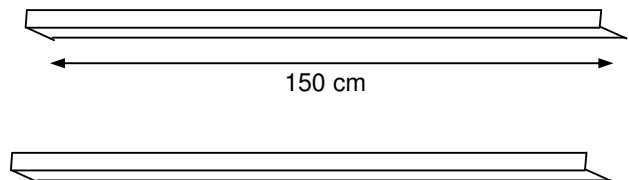

Using arc weld, attach the angle sections to the top covers as shown in figure 32 in order to seal off any gas escape during the time of oven operation.

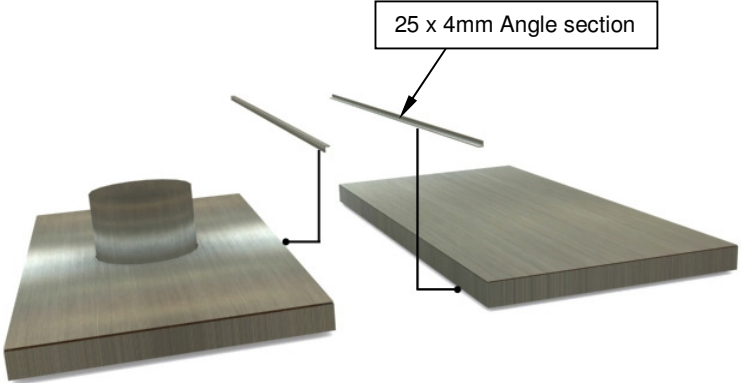

Fig 39

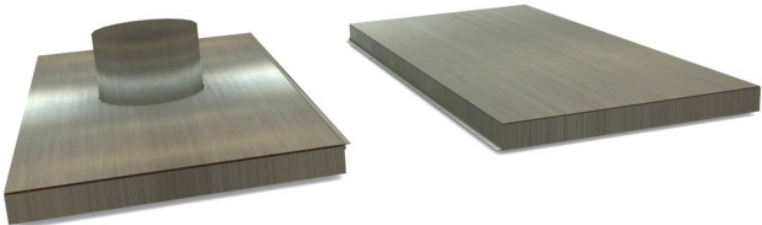

Fig 40

6.46 Proceed and fix two sizable handles on each of the top covers as shown in figure 41.

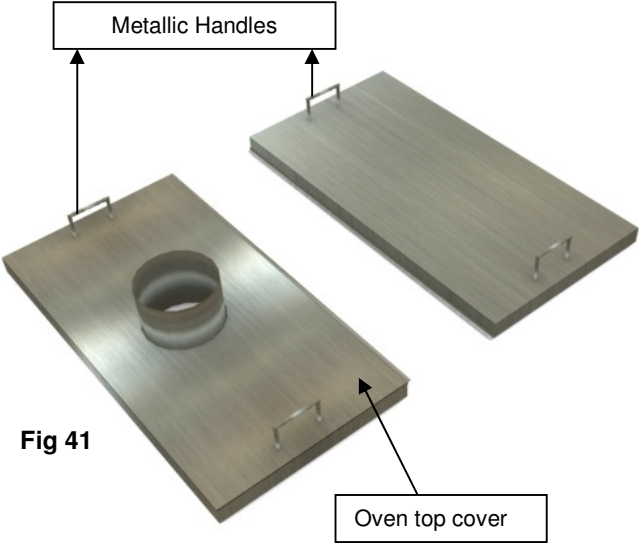
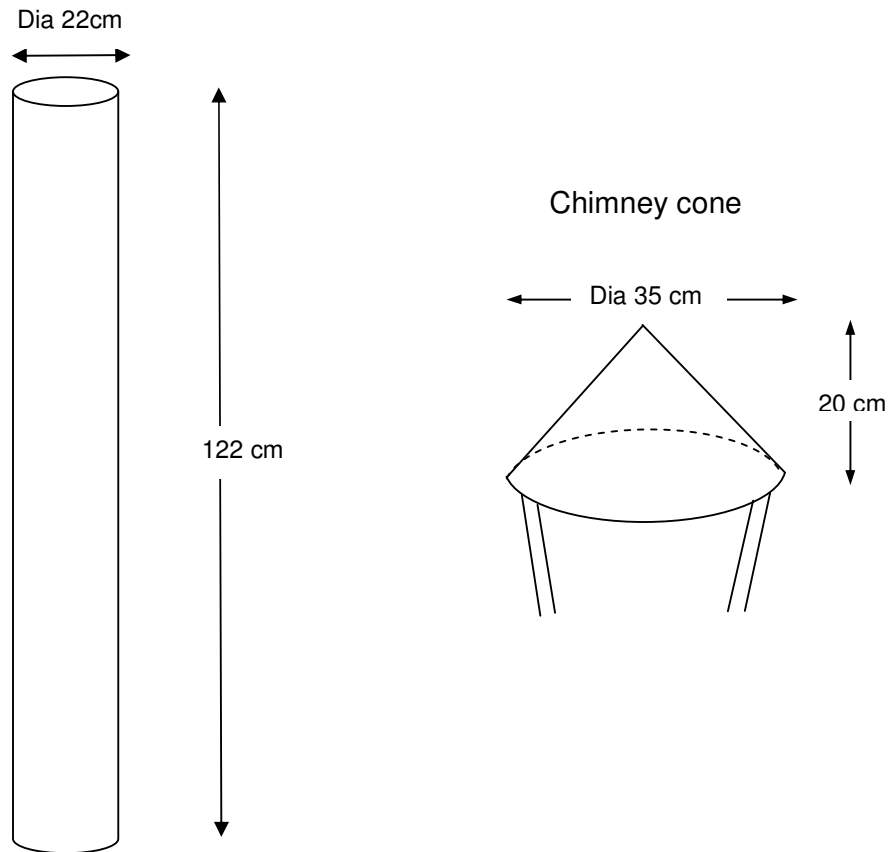

Fig 41

6.47 Roll the 2 mm sheet off cut labelled **Q** into a 22 cm diameter X 122 cm long chimney. Fasten the edges using the seaming method as was done with the chimney adaptor. Attach a cone at its top. Keep it for use at a later stage.



6.48 Lay down a C – Section measuring 40 x 40 x 4mm x 6m and cut off two sections each measuring 40 x 40 x 4 x 450mm. Lay down another MS Plate. Measuring 40 x 40 cm x 8mm.

This combination will construct a secondary protection for the oven box against direct contact with flames from the combustion chamber that usually destroy and reduce oven box durability. See fig 42.

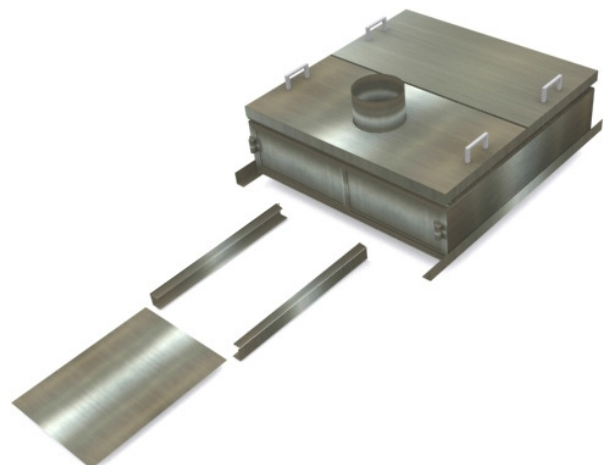

Fig 42

Use bolts or arc welding to attach the two C-Sections at spacing of 40 cm apart beneath the metallic box in a central position as shown in figure 43.

The height of the C – Section automatically provides the space between the oven metallic box and the 8mm plate. It is approximately 7cm maximum.



Fig 43

6.48 Weld 2 pieces of 6 X 6 cm spaced mesh on two 118 X 59 cm rectangular hollow section frames.

Weld sliding levels for the mesh frame to support it inside the metal box at 5 cm above from the bottom.

This mesh will hold the trays with baking products (bread, cakes etc), during baking, protection from burning.

6.49 Insert clay tiles (Heat retention tiles) on the floor of the baking chamber.

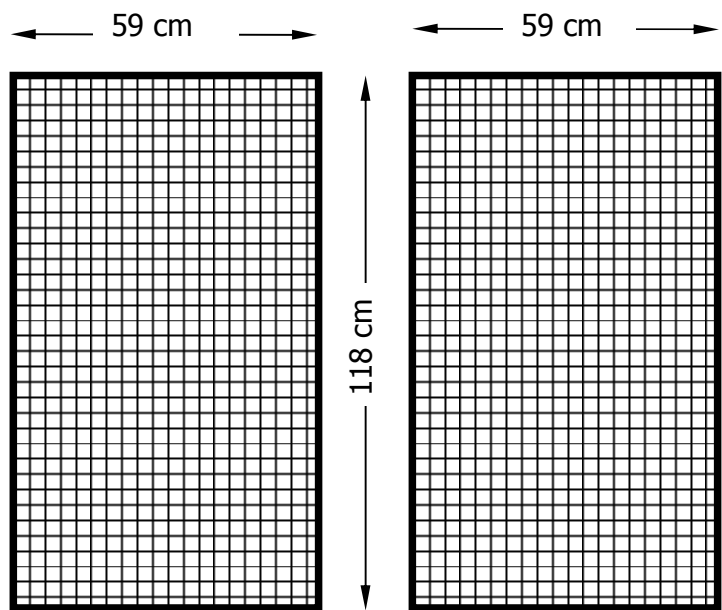

6.50 Place the mesh frame into the box.

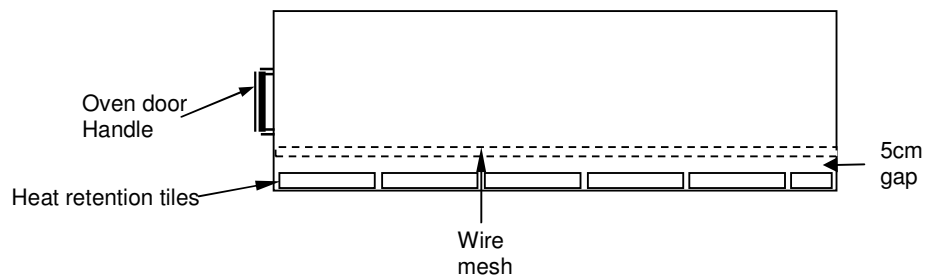

7.0 FITTING METAL BOX ON THE BRICK STRUCTURE

7.1 Fit the box in the brick structure and ensure a 3 cm gap between the box and the vertical insulation (left, back and right). The gaps between the front of the box and the brick structure should be sealed to avoid leakage of fire.

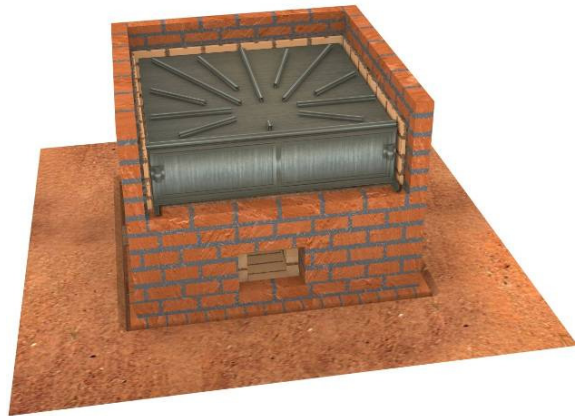

Fig 44

7.2 Cover the top of the oven with the tops fabricated in **Fig 41**. Place them on the radial hollow segments on top of the box assembly. They should leave an extension beyond the box of 15 cm on either side across as shown in figure 45.

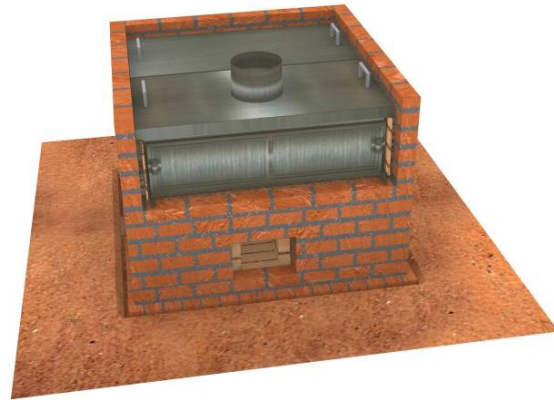
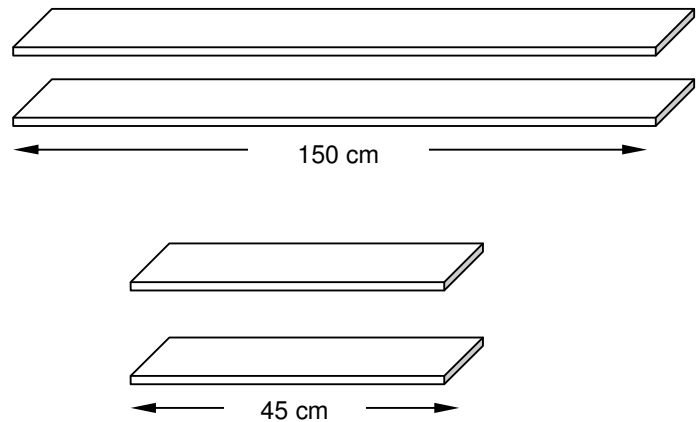

Fig 45

7.3 Lay down Flat sections (Sq. 50 X 3 X 6000 mm) and cut them into segments to fit in the gaps of the oven body.



7.4 Place the flat sections on the front of the oven body to seal off any escape of heat as shown in figure 46.

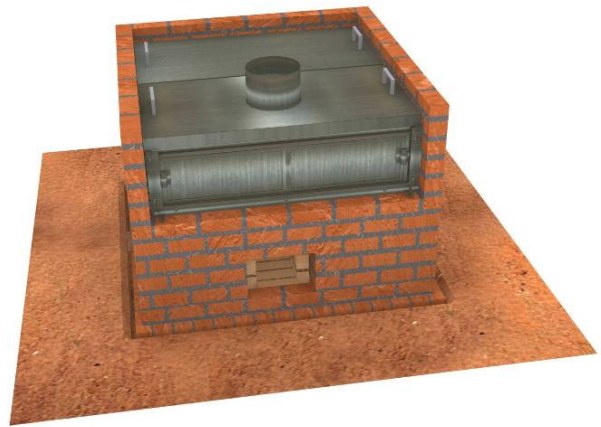

Fig 46

7.5 Proceed and seal off any other possible leakage joints with silicon gel. This will ensure proper heat /energy management in oven utilisation and should regularly be checked to stop leakages.

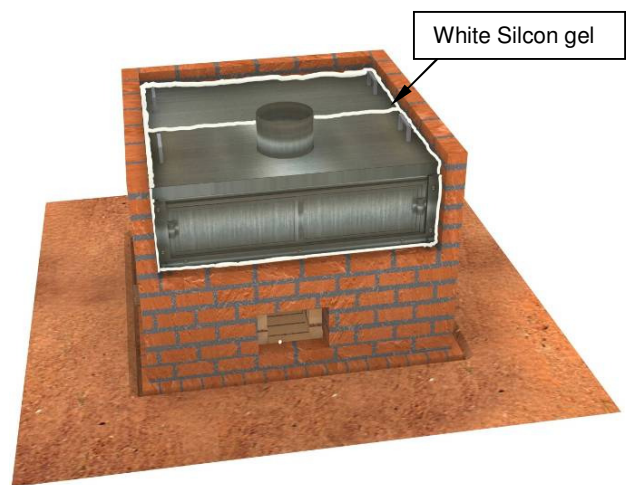

Fig 47

7.6 Plaster the oven walls using an appropriate mix of cement and sand in the ratio 1:3.

7.7 Attach the chimney cone to the chimney pipe and Slide it onto the chimney base.

7.8 Allow a period of 10 days for the cement to bond and all the oven parts to dry effectively. The oven will be ready for use after this.



Fig 48

PART 2:

8.0 DOUBLE DECK ROCKET BAKING OVEN

The double deck rocket baking oven is constructed following the same procedure as that for the single deck rocket baking oven explained in PART 1 of this manual.

This oven has got a total baking capacity of 44 1kg loaves accommodated on 8 trays at ago.

It offers all the other benefits as mentioned for the case of the single deck rocket baking oven.

To proceed in construction of the double deck rocket baking oven, follow the drawings on the next page.

8.1 DOUBLE DECK ROCKET BAKING OVEN

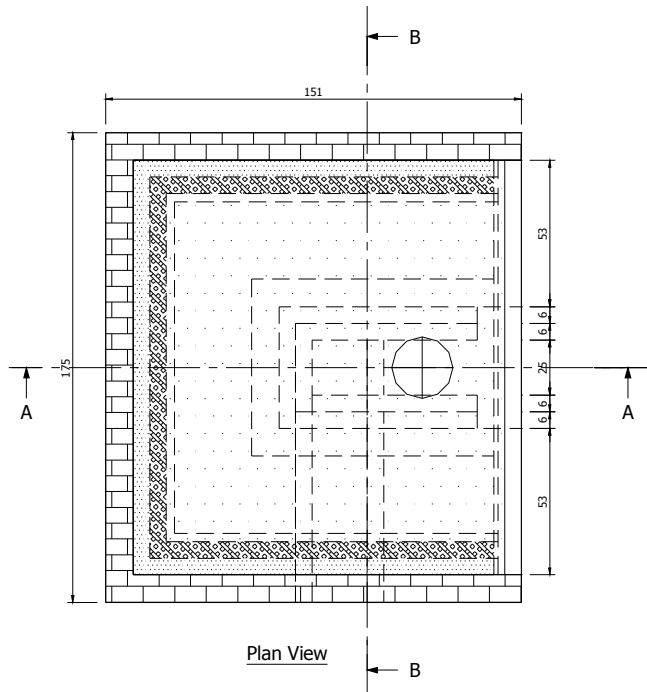

The Firewood Rocket Baking Oven

Baking Chamber: Double deck (120x120x70cm)
 Fuel: Firewood
 Dimensions: cm
 Designed by: MEMD/GTZ-PREEEP
 Drawn by: Leonard Mugerwa
 Date: November 2008

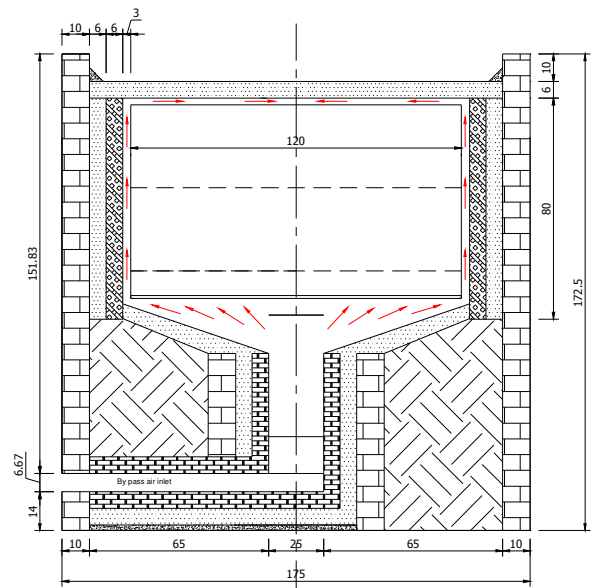
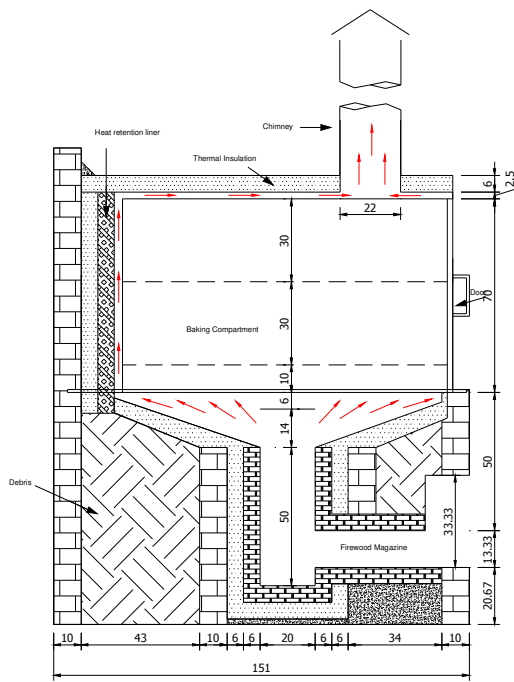
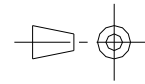

9.0 USING THE OVEN

The oven is now ready for use. It is suitable for use in baking all common baking products including bread, cakes, cookies etc.

Note: *This manual has been written for the purpose of technical guidance in oven construction and maintenance only. It is important that the person using this oven for baking should have prior training in baking skills.*

When using the oven it is advisable to use small amounts of dry chopped firewood. It is also important to observe the following recommendations

9.1 Efficient baking practices

- ❖ Always use dry firewood split into thin pieces. Wet firewood takes longer to burn and produces a lot of smoke.
- ❖ Preheat the oven to the desired temperature before loading it.
- ❖ Avoid feeding too much firewood into the oven. This will waste wood and burn your products
- ❖ Always remove any ash from the combustion chamber before lighting the oven.
- ❖ Avoid frequent opening of the oven door as this results in heat loss.
- ❖ Prepare your dough beforehand so that it is ready when your oven reaches the right temperature. This helps to save time and firewood.
- ❖ Proof and baking times must be synchronized so that both the oven and dough pieces are ready at the proper times.
- ❖ Bake a full load each time.

9.2 Cleaning the oven

The oven should be cleaned only when it is not in use (i.e. it should be cold).

- ❖ **Baking chamber**
Open the baking chamber door to clean the baking chamber. This should always be done at least twice a week.
- ❖ **Combustion chamber**
Slide out the firewood shelf and remove the wood ash from the firewood feed chamber. Place back the firewood shelf after removing the ash. This should always be done before lighting the fire.
- ❖ **The oven body**
Use a damp cloth to clean the oven walls and the oven top covers. This should be done at least twice a week to avoid accumulation of dust on the oven.

❖ **Chimney**

Lift the chimney off its base. Remove soot from its inside using a brush with a long handle (or similar tool). Place back the chimney on its base. This should be done every 2 a month to avoid clogging.

Note: The chimney has been designed so that it can easily be placed (attached) on and lifted (detached) from its 30 cm high base to allow for cleaning. Care should be taken to avoid deforming it and its cone.

Table 6: Summary of cleaning schedule

Oven Part	Frequency of cleaning	Purpose
Baking chamber	At least twice a week	Remove crumbs
Chimney	After 4 weeks	Remove soot
Combustion chamber	Always before lighting fire	Remove wood ash
By pass Air inlet	Always before lighting fire	Remove wood ash
The oven body	At least twice a week	Remove dust
Bottom plate	Once in six months	Check for strength
Oven Cavities (flue gaps)	Once in Six months	Remove soot and dust.

9.3 Oven maintenance and repair

It is advisable to perform oven inspection to identify faults and provide the necessary remedy to check further damage.

Table 7: Oven maintenance checklist

Oven Part	Fault to be checked
Baking chamber	Wear and tear
Baking chamber door	Looseness
Chimney	Wear and tear
Combustion chamber insulation	Cracks, wear and tear
Firewood grate	Cracks in tiles, wear and tear
Heat retention tiles	Wear and tear
Oven door latch, handle, hinges	Wear and tear
Oven walls	Cracks, wear and tear
Top insulation	Flu gas leakage, wear and tear
Wire mesh	Wear and tear