

MICRO HYDRO POWER SCOUT GUIDE

A FIELD WORKER'S MANUAL

KNOW HOW TO DO

HYDRO

POWER

INGENIEURBÜRO
VALENTIN SCHNITZER

gtz | Dutch-German Partnership
Energising Development
Access to Modern Energy Services –
Ethiopia (AMES-E)

IMPRINT:



Dutch-German Partnership
 Energising Development
 Access to Modern Energy Services –
 Ethiopia (AMES-E)

ACCESS TO MODERN ENERGY SERVICES –
 ETHIOPIA (AMES-E)

ADDIS ABABA, ETHIOPIA

P.O. BOX 12994

PHONE: +251 . 11 . 6451020

FAX: +251 . 11 . 6463653

MAIL: JOACHIM.GAUBE@GTZ.DE



HYDRO POWER – V. SCHNITZER,

INDUSTRIESTR. 100

69245 BAMMENTAL, GERMANY

PHONE: +49 . 62 23 . 4 75 32

FAX: +49 . 62 23 . 4 81 59

MAIL: HYDRO-POWER@T-ONLINE.DE

© 2009 HYDRO POWER, AMES – E / GTZ

AUTHOR: VALENTIN SCHNITZER

GRAPHIC DESIGN: BRUNO DORN

ILLUSTRATIONS: EVA BAUMANN, BRUNO DORN

Contents

WORDS OF APPRECIATION	4
FOREWORD	5
1. OVERVIEW	6
1.1 Components of plant	6
2. HOW TO PUT YOUR PLANT ON PAPER	8
3. FLOW DETERMINATION METHODS	12
3.1 Velocity-area method (rough estimate)	12
3.2 Weir Method (rectangular)	14
3.3 (Salt) Dilution method	16
3.4 Current meter method	17
3.5 Design Flow Determination	18
3.6 Catchment area	19
4. HEAD MEASUREMENT METHODS	20
4.1 General	20
4.2 Spirit level and plank (or string)	20
4.3 Pocket sighting level	22
4.4 Angular Levelling	24
4.5 Meridian clinometer method	25
5. POWER CALCULATION	26
5.1 Principles of power calculation	26
6. CIVIL WORKS	28
6.1 Weirs	28
6.2 Intake	32
6.3 Channels	34
6.4 Discharge calculation for a straight rectangle channel in concrete or plastered mason work	38
6.5 Discharge calculation for a straight trapezoid channel in natural stone masonwork or rough concrete	40
6.6 Spillways	42
6.7 Forebay	44
6.8 Penstock	46
6.9 Pipe manufacturing	48
6.10 Flange Coupling	49
6.11 Power House	52
6.12 Steel works – gates, screens	54
6.13 Trash rack	56
6.14 Civil works with natural stones	58
6.15 Where and how to get the stones	59
6.16 Stone extraction and preparation	60
6.17 Stone extraction and preparation: tools	61
6.18 Breaking the stone: traditional methods	62

6.19 Construction with natural stone	63	9. POWER UTILIZATION	94
6.20 Mortared stone masonry work	65	9.1 Multi-purpose	94
6.21 Footings and Foundations	66	9.2 Generator, retrofitted	97
6.22 Masonry works	68	9.3 DC-Electricity	98
6.23 Brick work / masonry	70	9.4 Battery based DC electrification	99
6.24 Recommended mortar	72	9.5 'Stand-alone' – AC power generation with 'mini grid'	100
6.25 Recommended plaster	73	9.6 3-phase AC synchronous generator	102
6.26 Concrete	74	9.7 Categories of control	105
7. CONVERSION OF WATER ENERGY	76	9.8 Grid	106
7.1 Development of horizontal water wheel plants	77	9.9 Concept for the mini grid	107
7.2 Overview vertical water wheel	79	9.10 Components of power distribution	108
7.3 Water wheel techniques	80	10. NATIONAL GRID OR COMMUNITY MINI GRID	109
7.4 Development of water wheels into modern turbines	81	11. ENVIRONMENT PROTECTION BY THE COMMUNITY	111
8. TURBINE OVERVIEW	82	12. THE ROLE OF THE HYDRO SCOUT	113
8.1 Crossflow	83	12.1 Community information and electricity demand	113
8.2 Impulse turbines: Pelton turbine for medium and high head	87	12.2 Project preparation	114
8.3 PAT / Pump as Turbine	89	12.3 Project implementation schedule	114
8.4 Turbine choice	92	12.4 Fact sheet	115
		BIBLIOGRAPHY AND SOURCES	116

WORDS OF APPRECIATION

Dear User,

It is with pride that we present this manual to you, respected user. Pride, because of this practical and handy result of the Dutch-German cooperation in the energy field worldwide. The Dutch have hundreds of years of experience with the power of water, with a substantial part of The Netherlands situated below sea level. Germany is well known as a country with high expertise in energy and renewable energy technologies. The knowledge gained in both countries is a valuable source for promoting power generation through hydro power.

We trust that this manual will provide you with a practical tool to develop the micro hydro power supply opportunities in your country. This will ensure a substantial leap in the contribution of this clean source of energy to the power supply esp. in the currently less privileged countries.

Apart from the anticipated business development opportunities this source of energy will provide for the rural communities. Even our global climate will not be harmed.

This publication mainly addresses the actors in the field. It has been designed as a tool to shape and prepare small-scale hydro power projects in a professional manner regarding their implementation. Moreover, it should be a thematic introduction not only for all who are involved in the process of hydro power development, but also for those which do not dispose of full background knowledge in this specific field.

Special gratitude has to be given to Mr. Valentin Schnitzer, the author, who made his experiences available in this scout guide.

It is our intention to arrange global dissemination of this manual. This implies that the hydro scouts worldwide can use it as a common basis for professional talks.

We wish you, the user, a successful and beneficial application of this manual.

FOREWORD

As Micro Hydro Power is a multi disciplinary task that covers surveying, planning, designing as well as land scaping, civil work, machinery construction, installation as well as the operation, management and service; the whole field on various levels, different actors – and the integration of all components for the whole hydro plant has to be kept in mind.

This Scout Guide addresses the target group of the actors in the field, those people who initiate the project and bring the ideas to the communities and owners. They define the project and bring it on the way towards implementation. This task is often performed by “mill wrights”, when watermills have a tradition in the country.

The Scout Guide should be a tool to shape the project in a rather professional manner as the base for the execution of the project.

At the same time the Scout Guide is a good introduction to all who deal in the process of hydro power development, having not the background of the specific field: It is also a good guide to the manufacturers of equipment to understand the full project and control their design and data.

It may also be a link to the practical field work for engineers who enter the Hydro field. Reference is made to sources to deepen the knowledge and refine the skill.

1. OVERVIEW

1.1 Components of plant

The energy of a waterfall or cascades is converted into power in the MICRO HYDRO POWER (MHP) plant:

For water diversion the river water level has to be raised by a barrier, the **weir [1]**.

The water is diverted at the **intake [2]** and conveyed by the **channel [3]** along the landscape's contour lines. The **spillways [4]** protect against damage from excessive water flow.

Water is slowed down and collected in the **forebay [5]**, from where it enters into the **penstock [7]**, the pressure pipe conveys the water to the **power house [6]** where the power conversion turbine, mill or generating equipment is installed.

The water is discharged via the **draft tube [8]** or a tail race channel in case of crossflow or Pelton turbines.

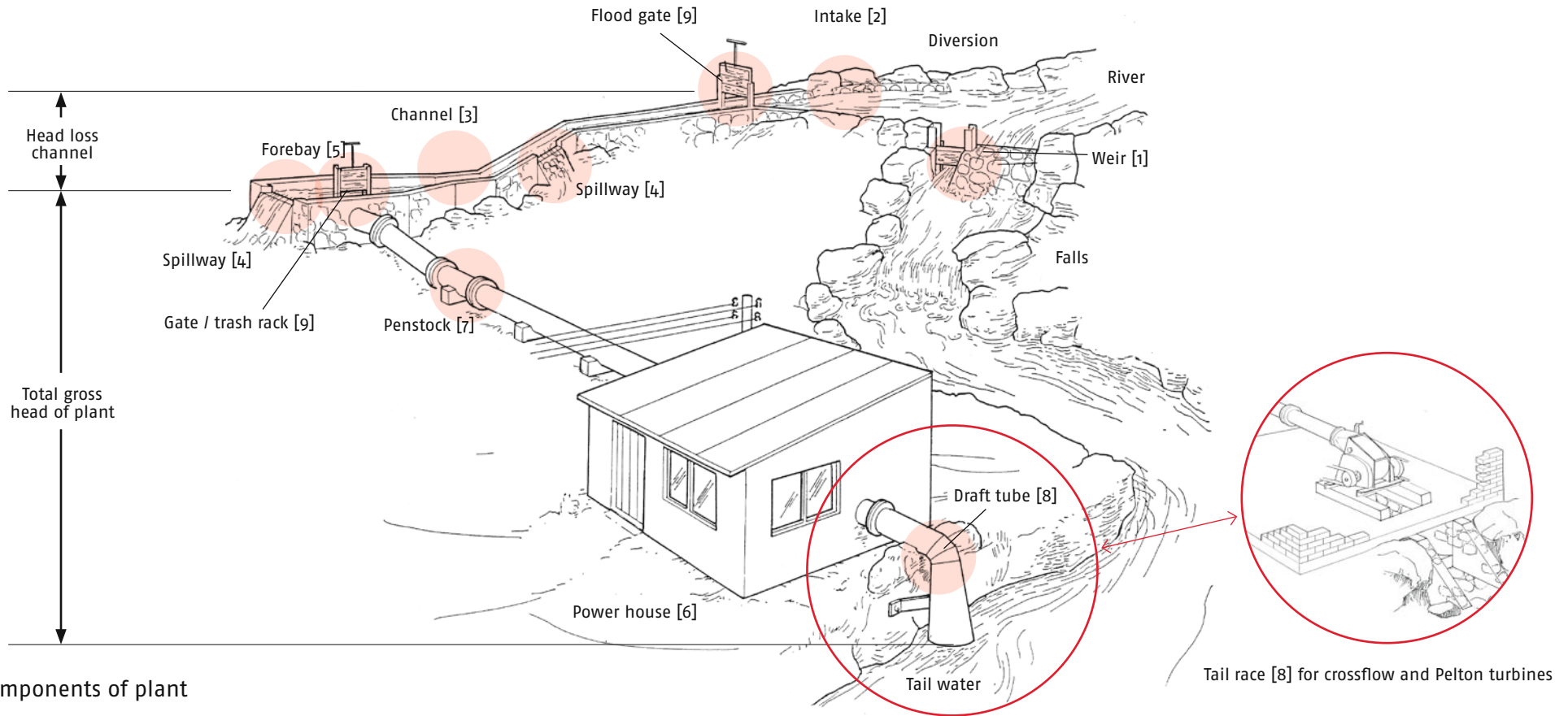

Components of plant

2. HOW TO PUT YOUR PLANT ON PAPER

Before you put your vision of the plant on paper it is crucial that you acquaint yourself with the terrain first. Check where and how to divert the water, identify the components of the plant in the landscape, ...

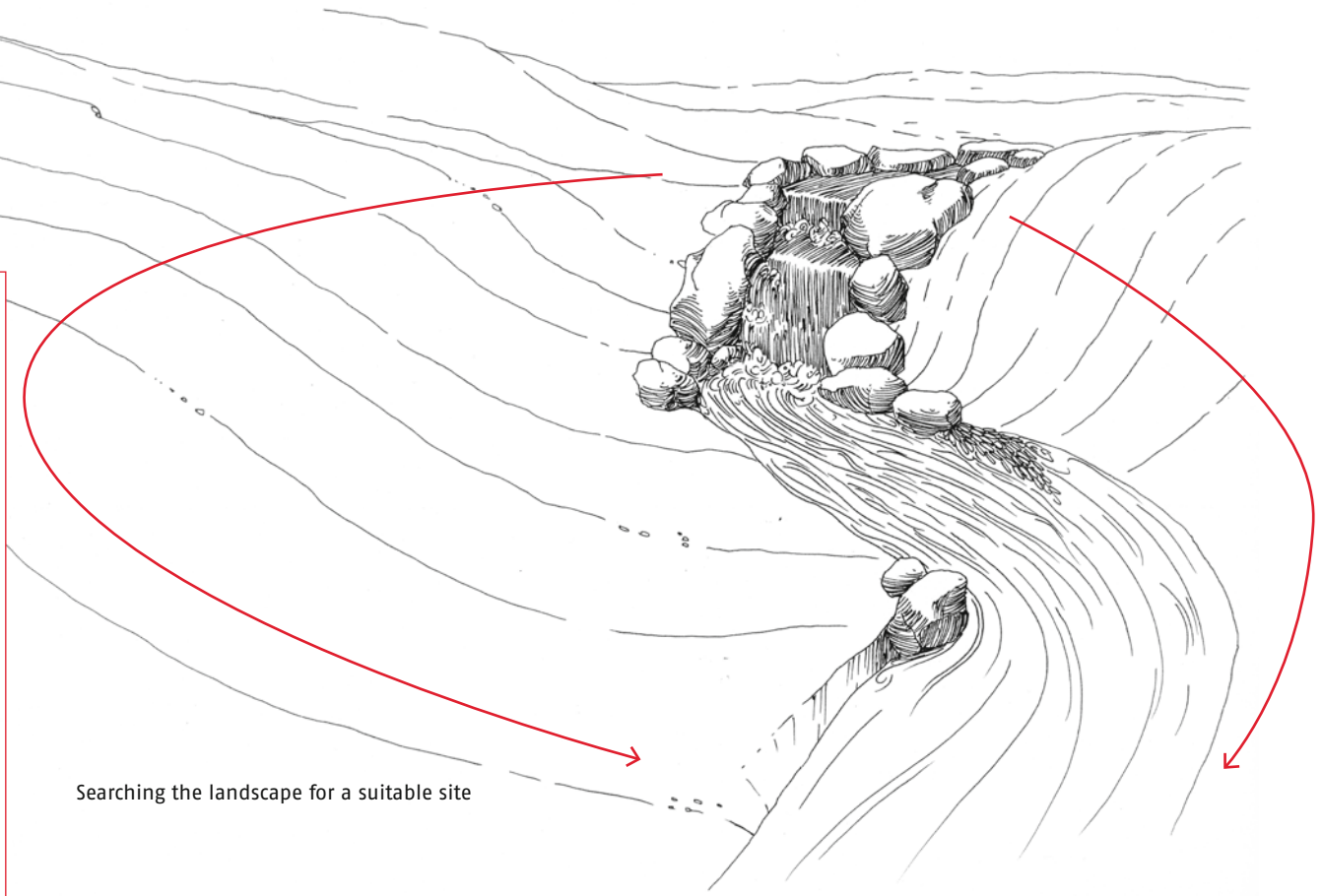
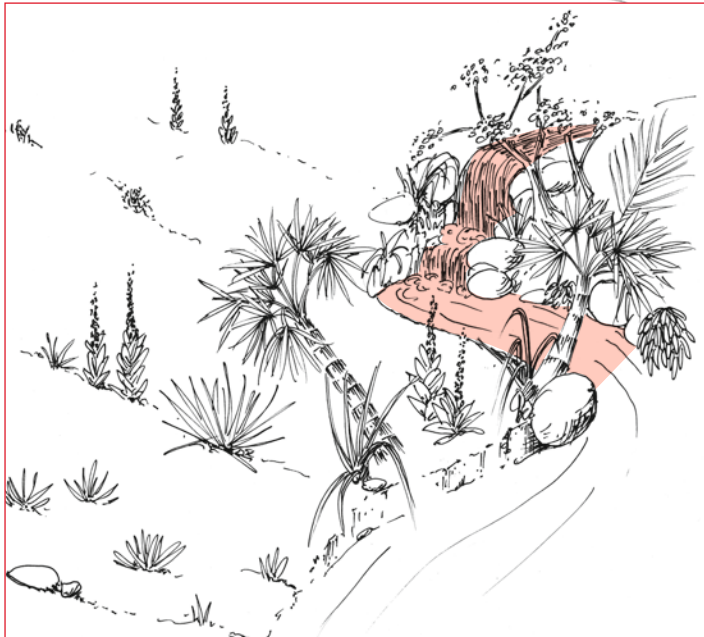

Searching the landscape for a suitable site

... mark for survey and consider options.
It is only then that you can actually plan
and develop your new plant.

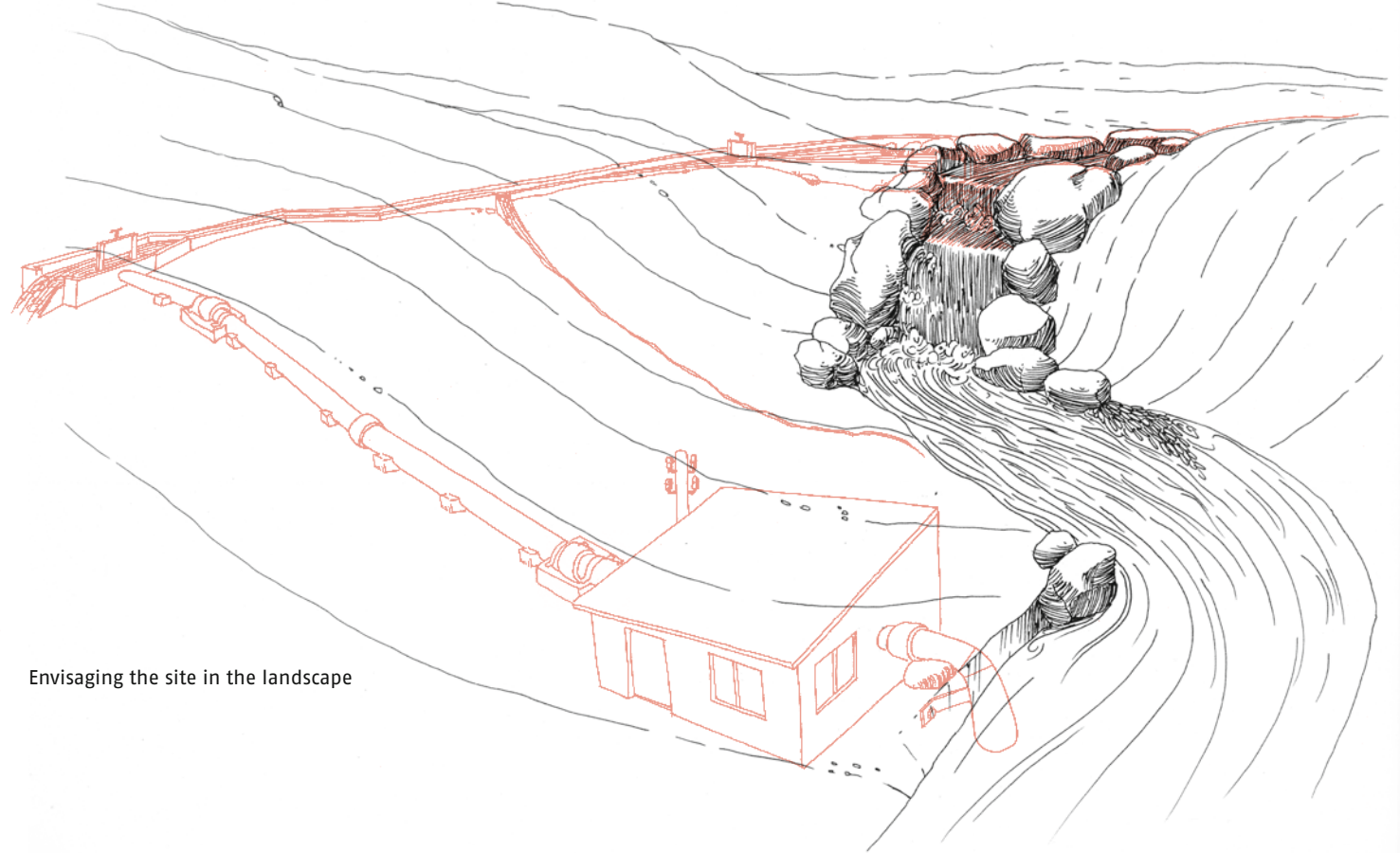

Envisaging the site in the landscape

Characteristic solutions for water conveyance

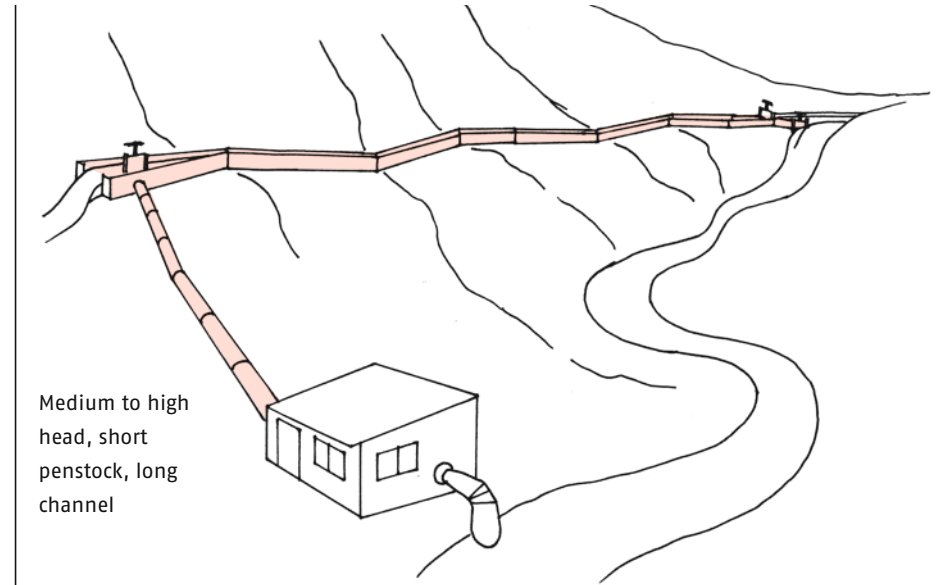
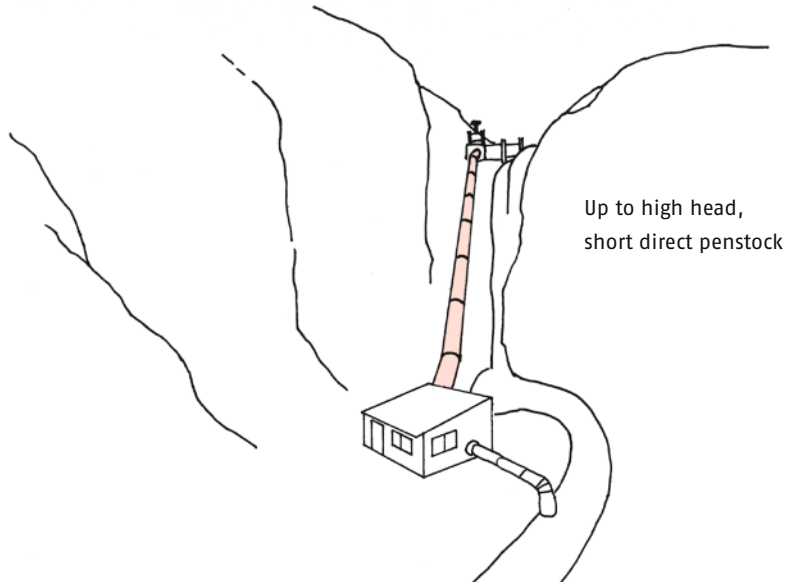

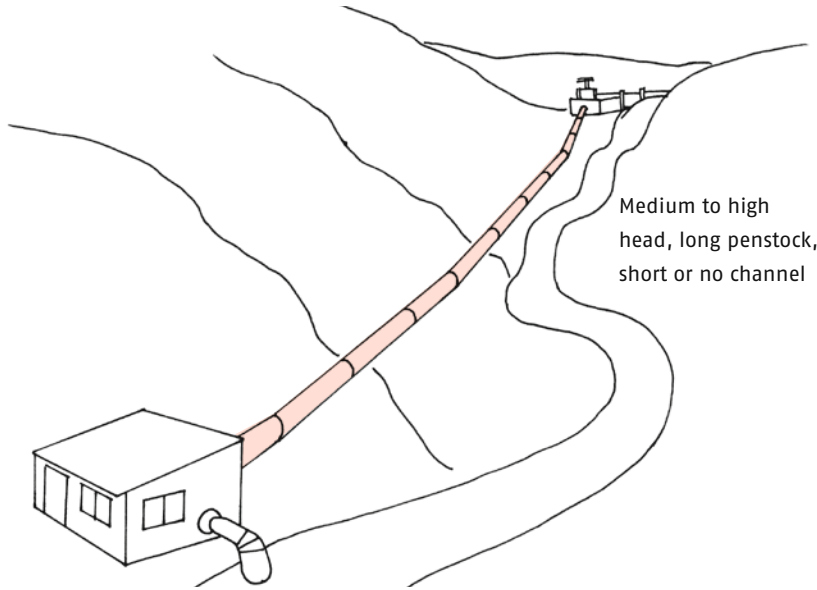

Medium to high head, long penstock, short or no channel

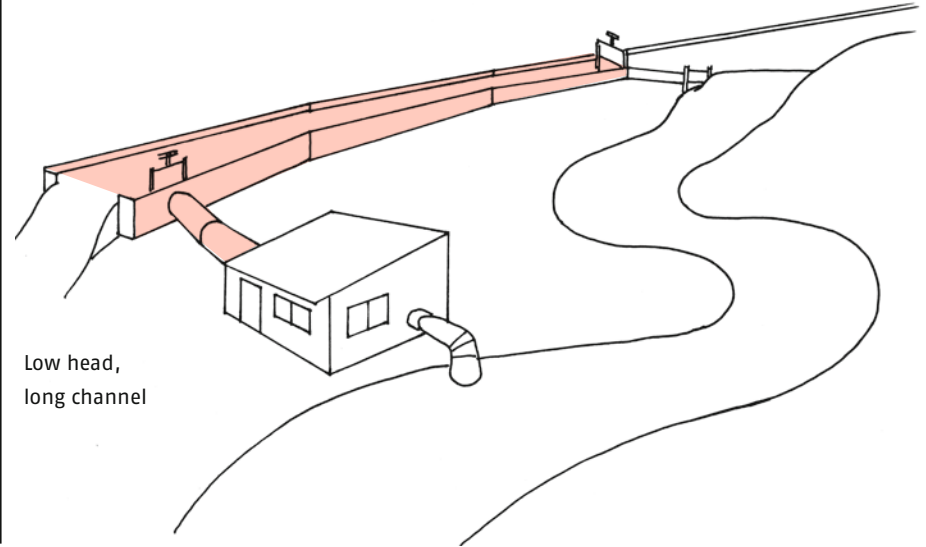

Low head, long channel

3. FLOW MEASUREMENT METHODS

Water flow and head / fall have to be measured to determine the power potential.

3.1 Velocity-area method (rough estimate)

Procedure:

Locate an evenly flowing area of water of a certain length L [m] where there is almost no turbulence.

Determine the area's cross section by measuring B [m] and H [m]:

$$A = B \cdot H$$

In order to determine velocity V [m/sec] measure the time T [sec] it takes for a float to travel the above determined length L (allow floats to accelerate before the start), then divide length L by time T .

$$V = \frac{L}{T}$$

To determine the discharge coefficient Q multiply velocity V by cross-sectional area A and correction factor c :

$$Q = V \cdot A \cdot c$$

A = cross-sectional area [m²]

H = height [m]

B = width [m]

V = velocity [m/sec]

L = distance [m]

T = time [sec]

Q = flow [m³/sec]

c = average correction factor due to the roughness of river bed is $\sim 0,75$

= shallow, rough: $\sim 0,5$

= channel, smooth: $\sim 0,85$

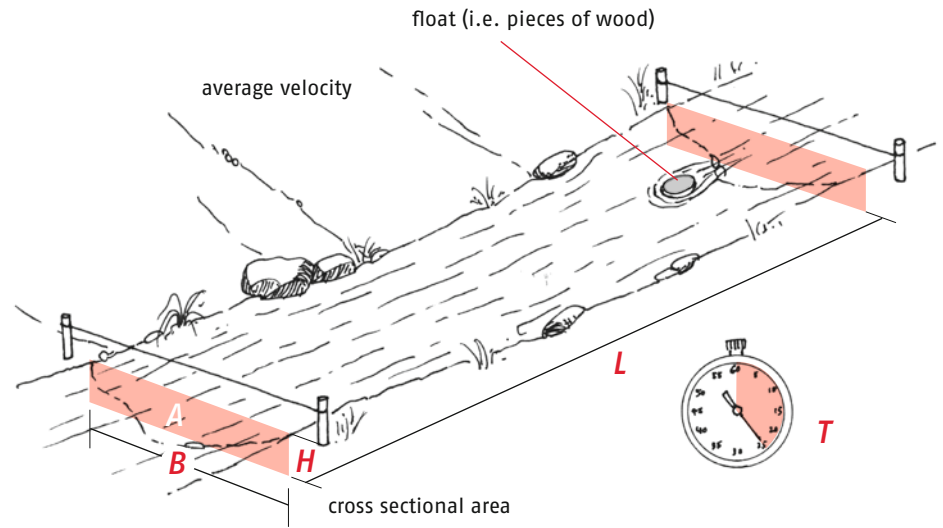
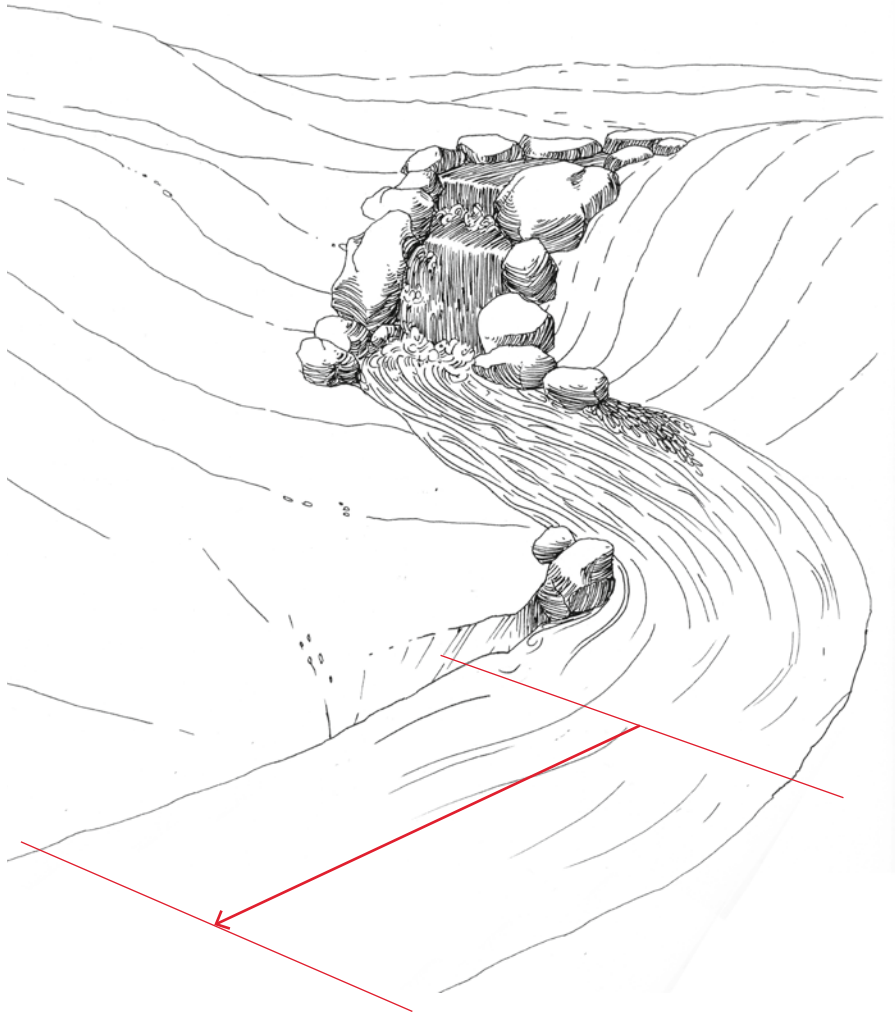

Illustration explaining the velocity-area method

3.2 Weir Method (rectangular)

More accurate flow measurements can be obtained by using or building a sharp crested weir:

Procedure:

1. Construct a weir with a notch and a sharp crest (for example, use a metal strip at the notch).
2. Install the weir at an evenly flowing area where there is almost no turbulence.
3. Install the stake at the level of the crest.
4. Measure height H [cm]
5. Measure width B [cm]
6. Check up for flow = Q [l/sec] in the table below

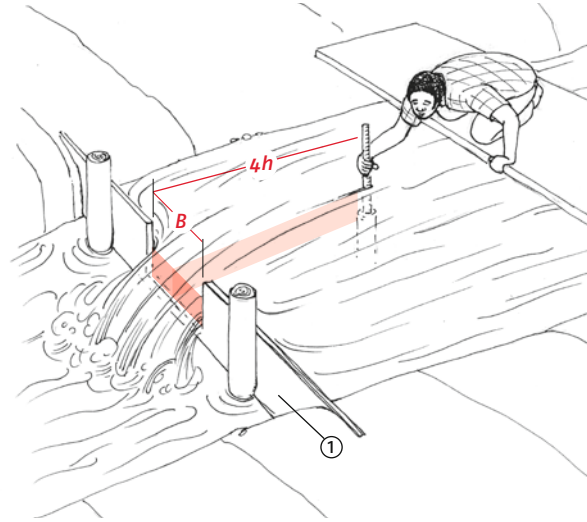
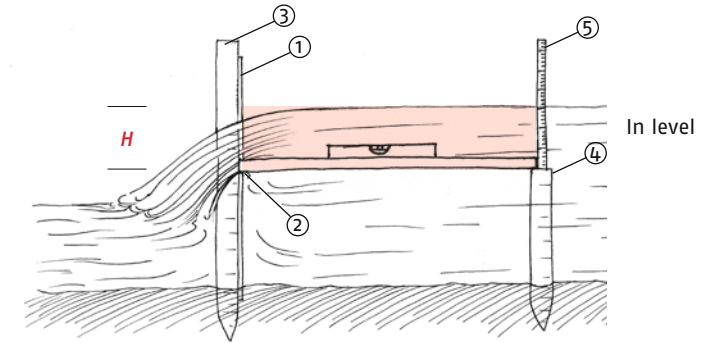

Illustration of how to take flow measurements using a rectangular weir



- 1 = weir plate
- 2 = sharp crest
- 3 = peg
- 4 = stake as base for taking measurements
- 5 = rule [cm]
- B = width of weir [cm]
- H = height of upstream [cm]

Example:
 $B = 70$ cm
 $H = 22,5$ cm

Use this chart to estimate the flow rate with the rectangular weir method:

Example:

B = 70 cm

H = 22,5 cm

Result: Q = 132 l/sec

Table / Flow = Q [l/sec]

Weir width = B (see sketch) [cm]

Overflow height	Weir width = B (see sketch) [cm]														
H [cm]	10	20	30	40	50	60	70	80	90	100	110	120	130	140	150
5	2	4	6	8	10	12	14	16	18	20	22	24	26	28	30
7,5	4	7	11	15	18	22	25	29	33	36	40	44	47	51	55
10	6	11	17	22	28	34	39	44	50	56	62	67	73	78	84
12,5	8	16	23	31	39	47	55	62	70	78	86	94	102	109	117
15	10	21	31	41	51	62	72	82	93	102	113	123	133	144	154
17,5	13	26	39	52	65	78	91	103	116	129	142	155	168	181	194
20	16	32	47	63	79	95	110	126	142	158	174	190	205	221	237
22,5	19	38	57	75	94	113	132	150	170	189	207	226	245	264	283
25	22	44	66	88	110	132	154	177	199	220	243	264	287	309	331
27,5	26	51	77	102	127	153	178	204	229	254	280	306	331	356	382
30	29	58	87	116	145	174	203	232	261	290	320	348	378	406	436
32,5	33	65	98	130	164	197	229	260	295	328	361	394	426	459	491
35	37	73	110	146	183	220	256	292	330	366	403	440	476	512	550
37,5	41	81	122	162	203	244	284	334	366	406	447	488	528	568	610
40	45	90	135	180	225	270	315	360	405	450	495	540	586	630	676
42,5	49	98	147	196	245	294	343	392	441	490	539	588	637	686	735
45	53	106	160	212	267	320	374	424	480	534	587	640	694	748	801
47,5	58	115	173	230	289	346	405	460	521	578	637	692	753	811	869
50	63	125	187	250	313	375	438	500	563	626	688	750	813	876	938

3.3 (Salt) Dilution method

Procedure:

1. Choose a certain length of stream where there are no large stagnant pools.
2. Mix the salt dilution by using pure table salt; a useful guide to quantity is 100 – 300 grams for each 0,1 m³/s of expected streamflow.
3. Calibrate conductivity meter to “normal” discharge (determination of prime conductivity).

Recommendations:

Use the full automatic conductivity meter to determine the discharge. (The procedure for manual discharge determination without a full automatic conductivity meter takes somewhat longer and is described in the detailed manual, e.g. EASYFLOW)

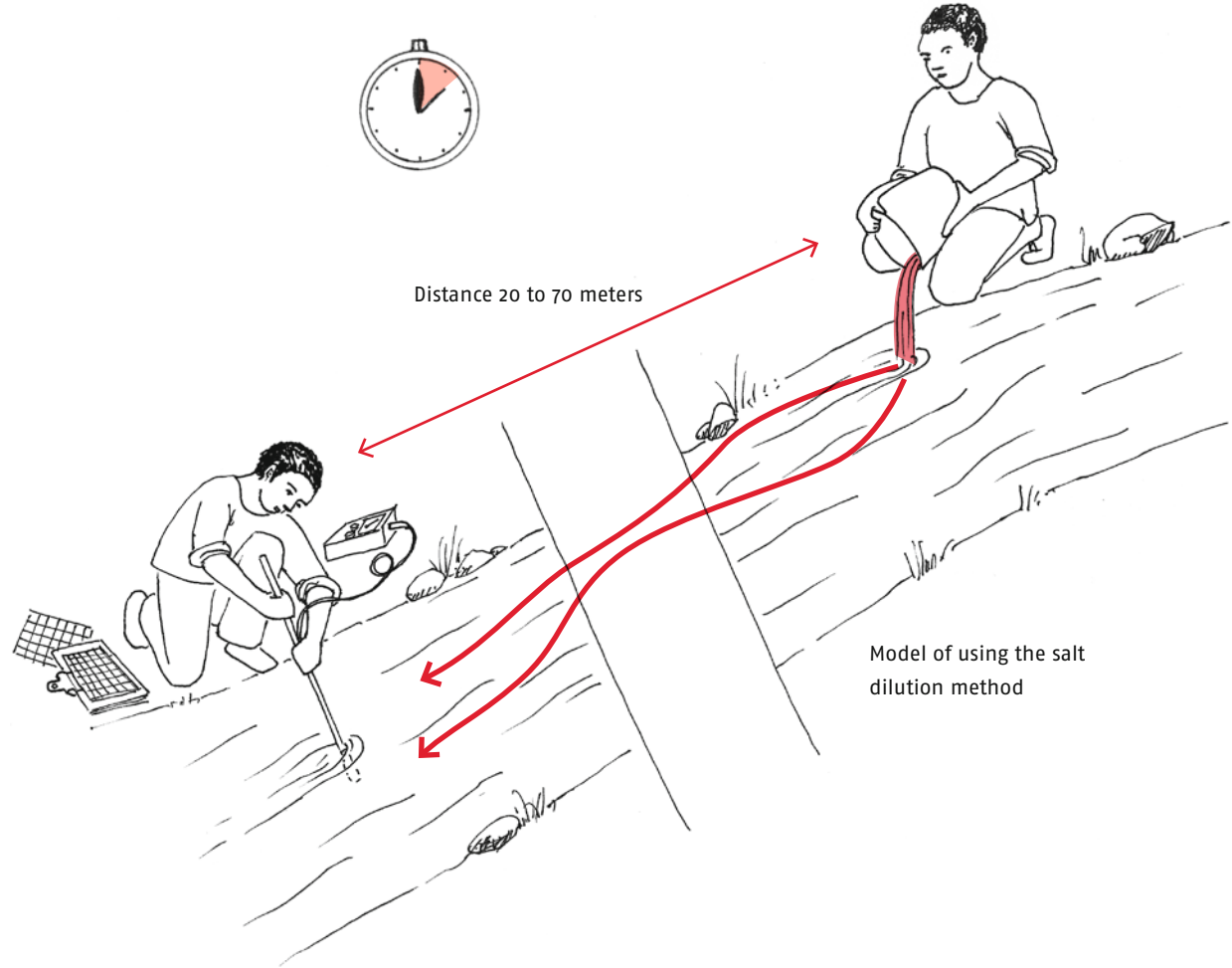

3.4 Current meter method

In order to obtain accurate measurements professionals in hydrological surveying, water departments, universities or other institutions use current meters for measuring. Often these experts will measure for you, i.e. for water rights, permissions etc.

Procedure:

- > Divide the cross section of a river into approx. equal sections.
- > Measure velocity for each individual section.
- > Multiply and calculate average velocity.

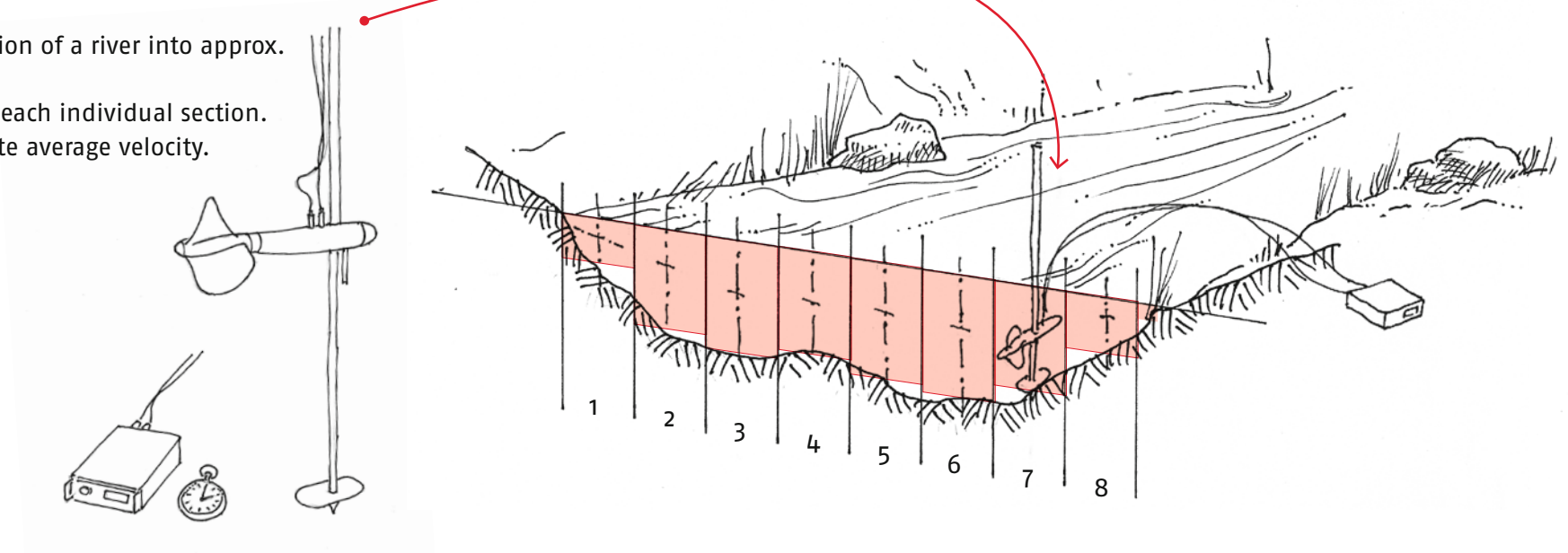

3.5 Design Flow Determination

The flow measured at a certain time of the year has to be related to the annual flow characteristics (“hydrograph”).

If measured in (extreme) dry season you may refer to this flow as “safe flow” of the future plant.

Hydrograph data may be available from gauging stations – then you can calculate to your site (put the catchment area from a 1:50 000 map in relation to the relevant gauging station).

The hydrograph data is evaluated in the flow duration curve (365 days equal to 100 %).

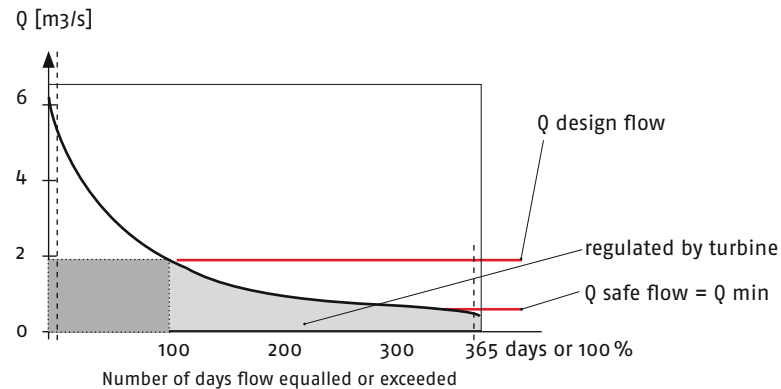
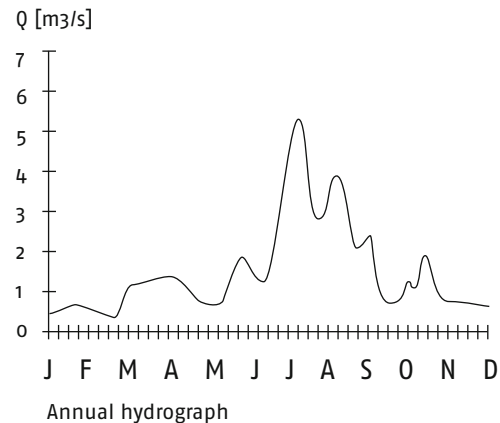

3.6 Catchment area

To calculate the catchment area use a 1:50 000 map.

Procedure:

1. Obtain 1:50 000 map of area.
2. Mark catchment boundary.

3. Get hydrological information for your area from a gauging station. (If there is no gauging station available, consult the next hydro water resource department or university hydrology expert to help you correlate to previously gauged catchments).
4. Establish flow duration curve.
5. Evaluate your power potential (see chapter 5, page 26).

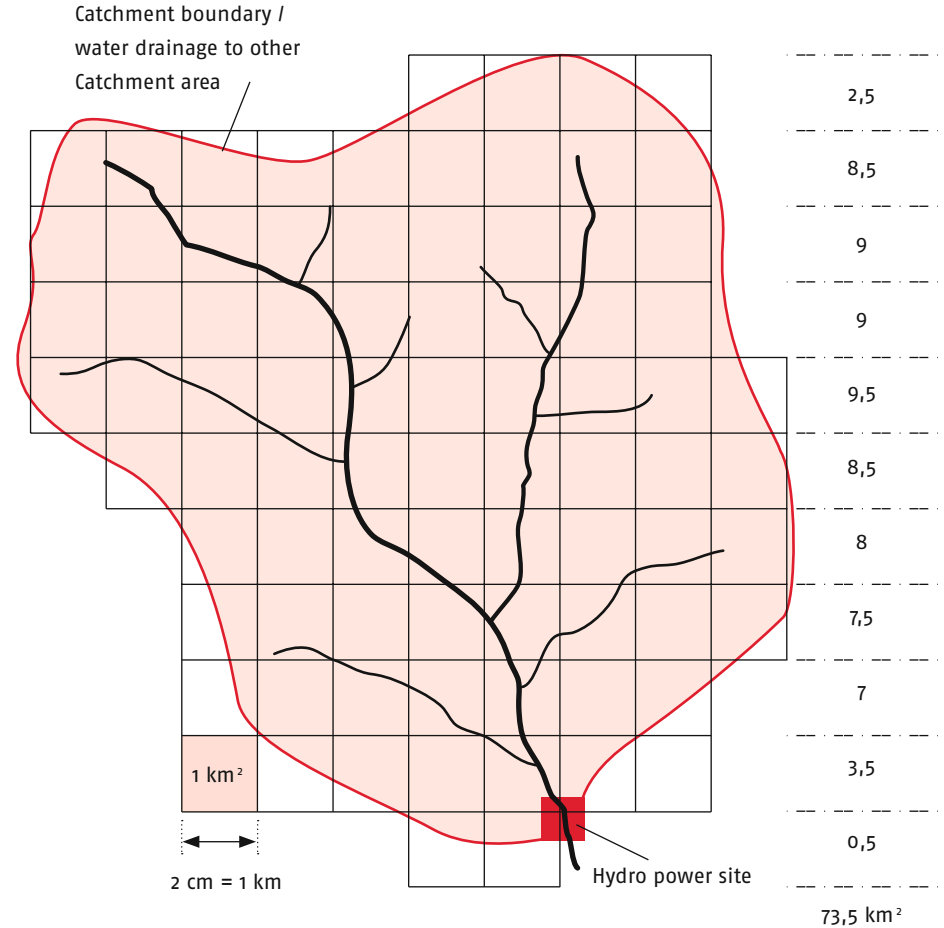
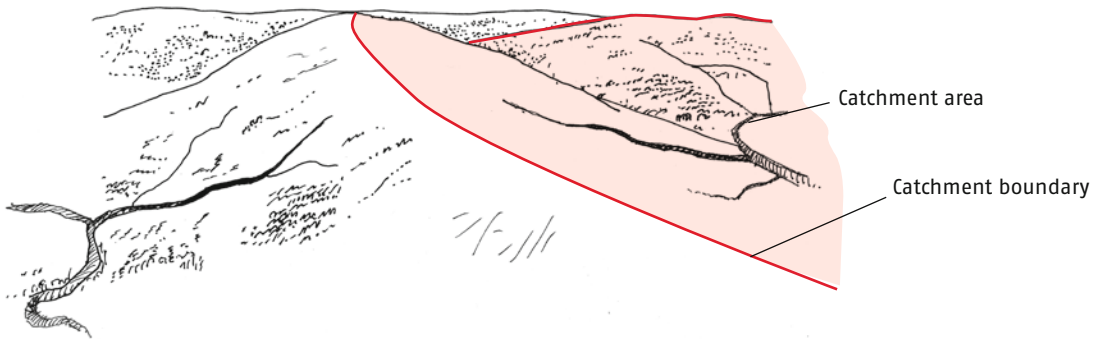

Scale: 1:50 000

4. HEAD MEASUREMENT METHODS

4.1 General

If detailed maps with contour lines are available or a topographical survey has been done, the gross head can be determined by consulting these aids.

Otherwise the following methods can be used to determine the head. Before you measure make sure to determine forbay, penstock position and power plant location first, as a basis of the plant design.

4.2 Spirit level and plank (or string)

This is a step-by-step procedure to determine gross head H_g between tail water level and upper water level (at waterfall / forebay), by using a spirit level and plank.

$$H_g = h_1 + h_2 + h_3 \dots + h_n$$

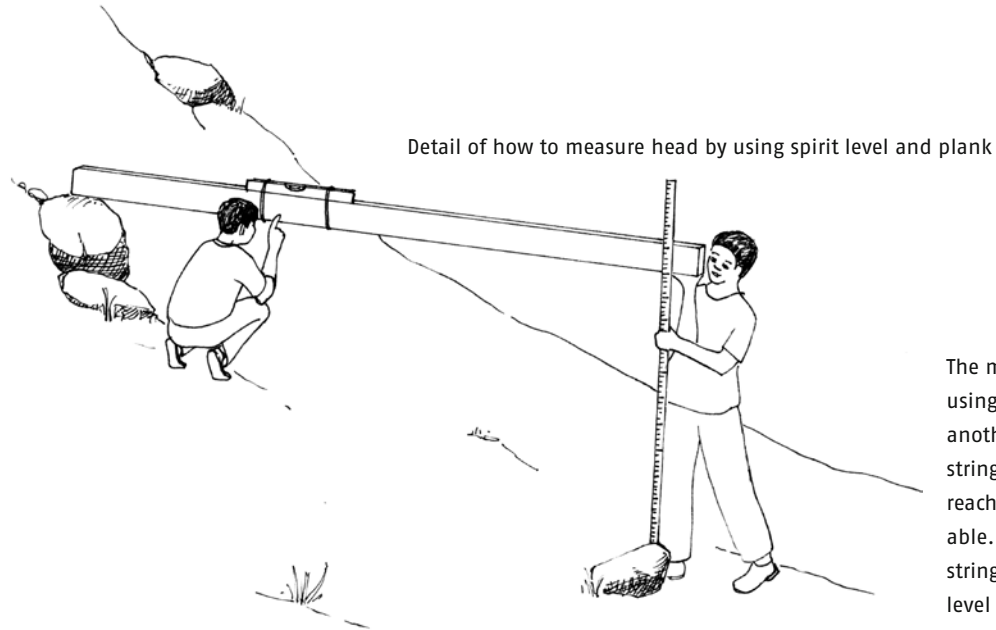

The most common variation is using a plank. Using a string is another alternative. With a string you could get a bigger reach, but it is less comfortable. You have to stretch the string and cannot fix the spirit level as easily as by means of a plank.

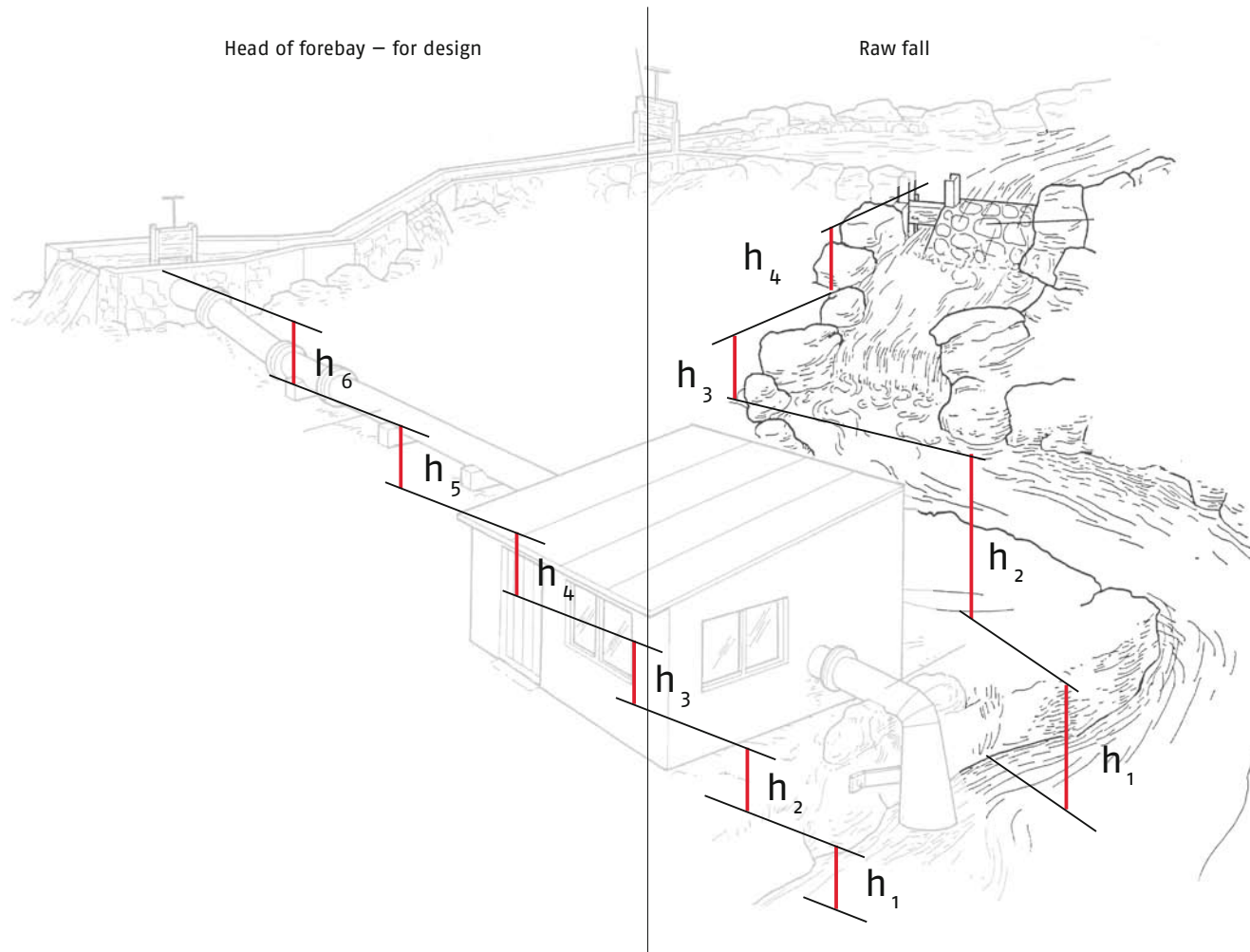

Head of forebay – for design

Raw fall

4.3 Pocket sighting level

In contrast to the above methods this method is easy and suited for quick approximation in the field. Some of its advantages are:

- > The job can be done by one person only.
- > There is no bulky equipment and it is easy to set up.
- > Easy and convenient to level long distances as well as steep slopes.

Pocket sighting level,
e.g. CST/Berger

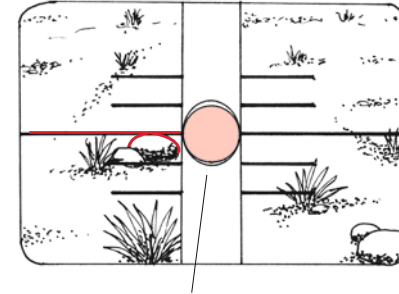

Bubble centered

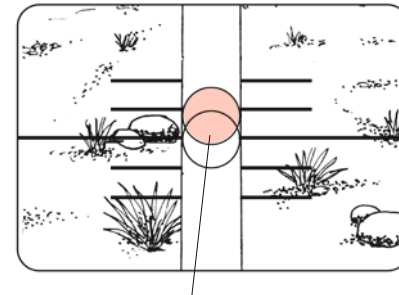

Bubble NOT centered

View through eyepiece, with bubble centered:

- > Start at the base (tail water) and mark the spot where you will position yourself next.
- > Move to this location and spot again.
- > Repeat the same procedure until you reach the top.

Total of sightings multiplied by distance from your eye to the ground equals total difference from base to top.

For further use how to gauge maximum distance and slope refer to the instructions that come with the pocket sighting level (i.e. CST/Berger).

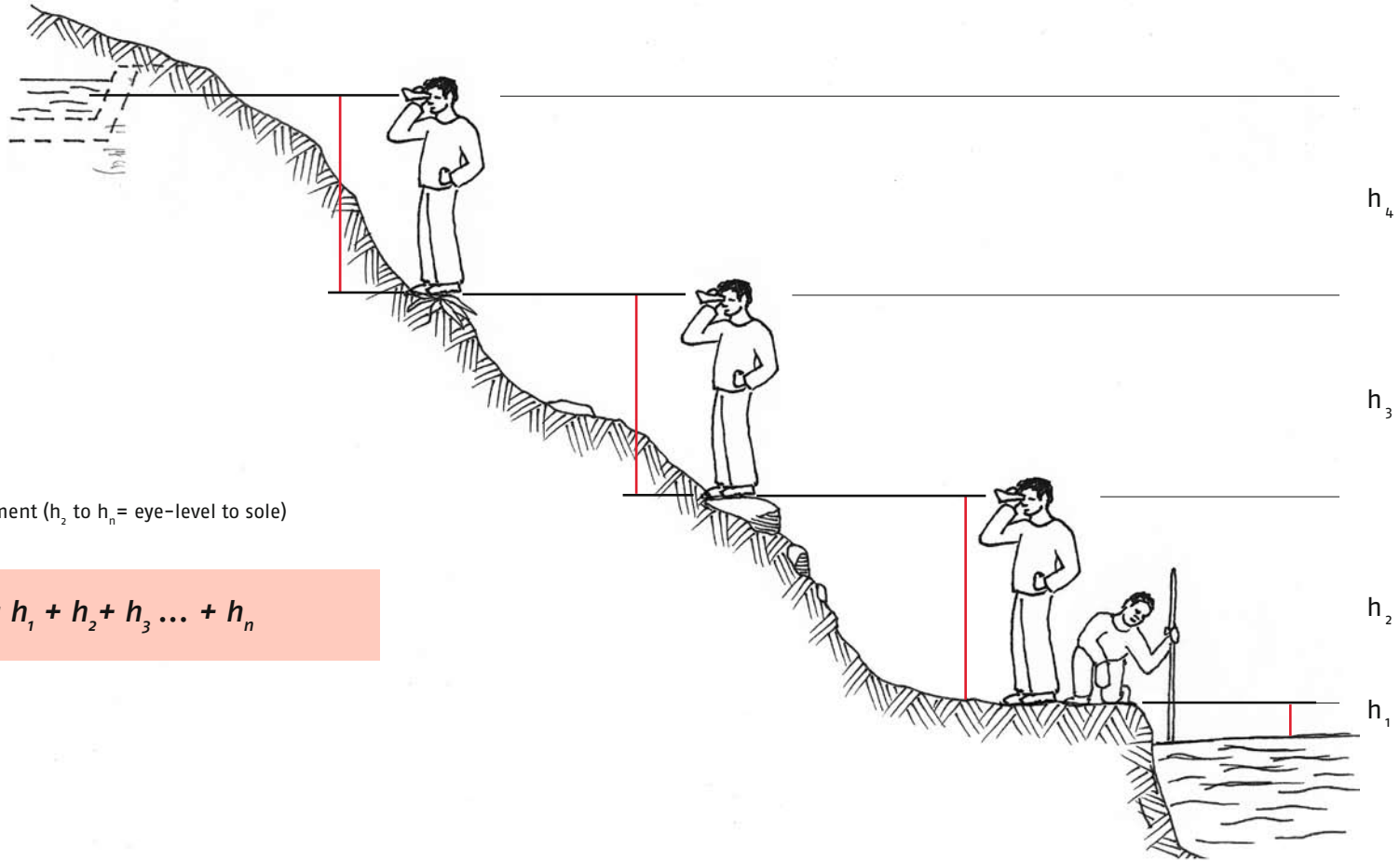

Sight level measurement (h_2 to h_n = eye-level to sole)

$$H_g = h_1 + h_2 + h_3 \dots + h_n$$

4.4 Angular Levelling

For angular levelling the following instruments can be used:

- > Clinometer (and tape)
- > Abney Level (and tape)
- > Theodolite
- > Total station

Further:
Use GPS or altimeter if available

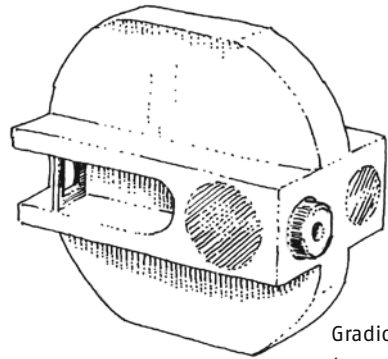

Gradiometer
(Breithaupt / Necli)

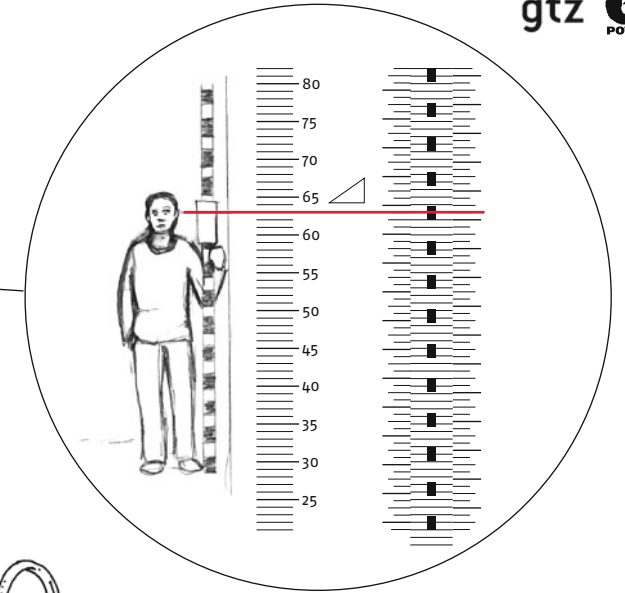
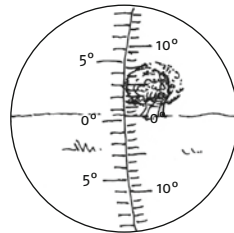
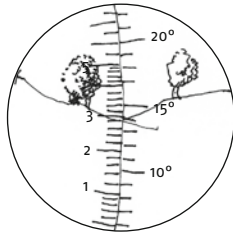

View through a clinometer

4.5 Meridian clinometer method

Use a clinometer or Abney Level to determine angle α (upward) or β (downward). Measure length L [m] with a tape. Then use the following formula to determine gross head:

$$H_g = L \cdot \sin \alpha$$

For H_g [m] deduct h_1 ($= h_2$)

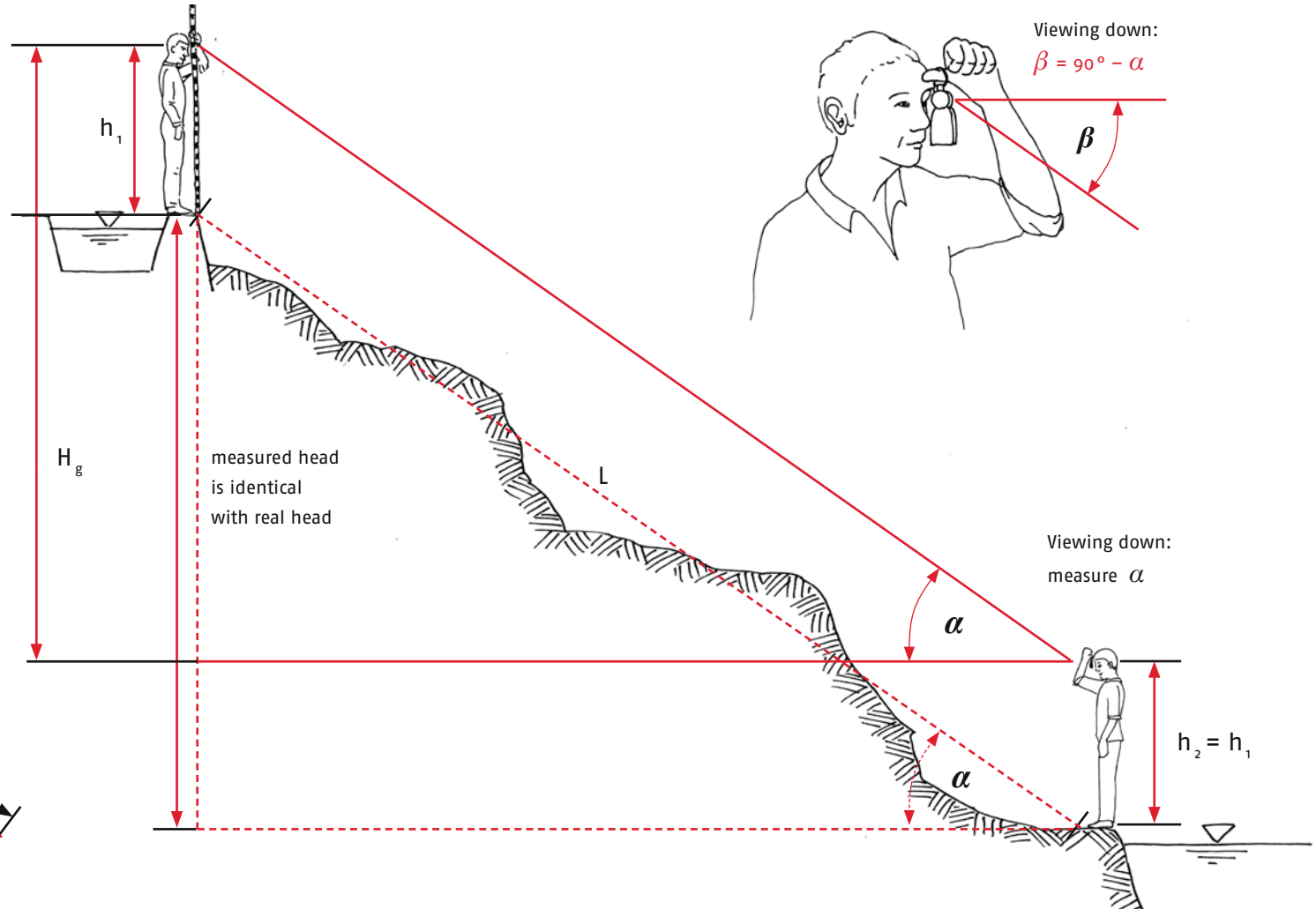
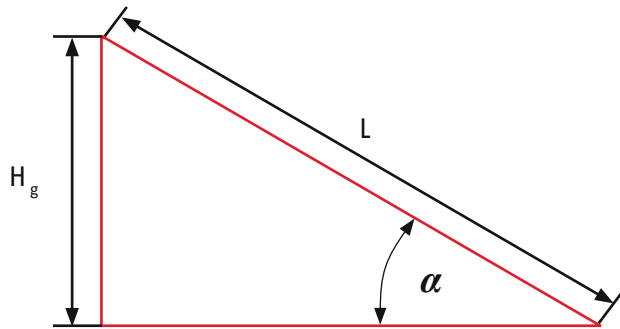

5. POWER CALCULATION

5.1 Principles of power calculation

First estimate / available power:

The power selected for turbine choice should meet the power demand of the following formula:

$$P = Q \times H \times \gamma \times \eta$$

Flow (Q): discharge passing through the turbine in [m³/s].

Head (H): net head between the upper and the lower water level in meter [m] – losses [m] (~ 10% of total head).

γ acceleration due to gravity.

(=9,81 kN/m³) = approx.: 10 for estimate

The overall efficiency η of turbine and electricity generation is assumed by approx. 60% (= 0,6) of the power estimate for $P < 50$ kW.

For power estimate consider:

P = power [kW]

Q = flow in dry season for "firm power"

if not enough – operate part load, provide storage basin for peaks (is peak back-up by diesel possible?)

Refer to design flow determination, see chapter 3.4, page 18

H = net head of forebay, deduct estimate penstock and plant loss (approx. 10 %) [m]

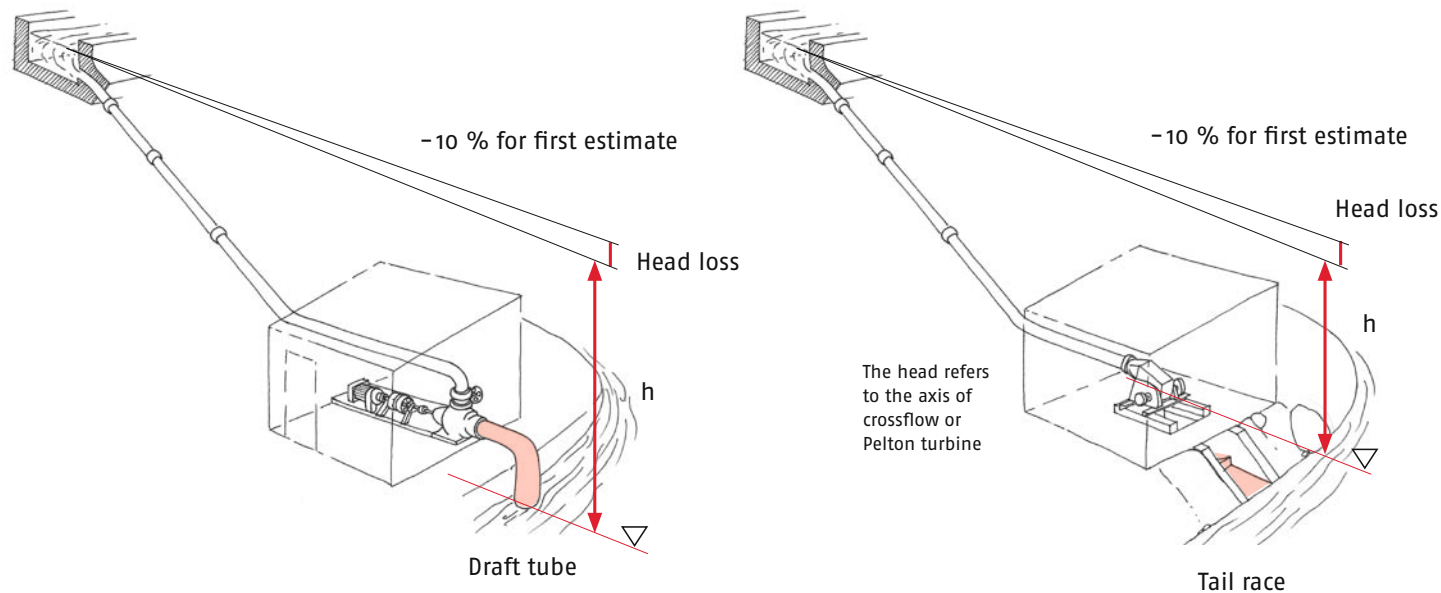

Power estimate = P [kw]

Discharge Q [m³/sec]	0,05	0,1	0,15	0,2	0,25	0,3	0,35	0,4	0,45	0,5	0,55	0,6	0,65	0,7	0,75	0,8	0,85	0,9	0,95	1	
Discharge Q [l/sec]	50	100	150	200	250	300	350	400	450	500	550	600	650	700	750	800	850	900	950	1000	
Head H [m]																					
1	0,3	0,6		1,2		1,8		2,4		3		3,6		4,2		4,8		5,4		6	
2	0,6	1,2		2,4		3,6		4,8		6		7,2		8,4		9,6		10,8		12	
3		1,8		3,6		5,4		7,2		9		10,8		12,6		14,4		16,2		18	
4		2,4		4,8		7,2		9,6		12		14,4		16,8		19,2		21,6		24	
5		3		6		9		12		15		18		21		24		27		30	
6		3,6		7,2		10,8		14,4		18		21,6		25,2		28,8		32,4		36	
7		4,2		8,4		12,6		16,8		21		25,2		29,4		33,6		37,8		42	
8		4,8		9,6		14,4		19,2		24		28,8		33,6		38,4		43,2		48	
9		5,4		10,8		16,2		21,6		27		32,4		37,8		43,2		48,6		54	
10		6		12		18		24		30		36		42		48		54		60	
11		6,6		13,2		19,8		26,4		33		39,6		46,2		52,8		59,4		66	
12		7,2		14,4		21,6		28,8		36		43,2		50,4		57,6		64,8		72	
13		7,8		15,6		23,4		31,2		39		46,8		54,6		62,4		70,2		78	
14		8,4		16,8		25,2		33,6		42		50,4		58,8		67,2		75,6		84	
15		9		18		27		36		45		54		63		72		81		90	
16		9,6		19,2		28,8		38,4		48		57,6		67,2		76,8		86,4		96	
17		10,2		20,4		30,6		40,8		51		61,2		71,4		81,6		91,8		102	
18		10,8		21,6		32,4		43,2		54		64,8		75,6		86,4		97,2		108	
19		11,4		22,8		34,2		45,6		57		68,4		79,8		91,2		102,6		114	
20		12		24		36		48		60		72		84		96		108		120	
25		15		30		45		60		75		90		105		120		135		150	
30		18		36		54		72		90		108		126		144		162		180	
35		21		42		63		84		105		126		147		168		189		210	
40		24		48		72		96		120		144		168		192		216		240	
45		27		54		81		108		135		162		189		216		243		270	
50		30		60		90		120		150		180		210		240		270		300	

Estimated electrical power P output at 60 % total efficiency.

Example of how to get estimated electrical power output:

Q = 300 l/sec or 0,3 m³/sec,
H = 8 m (net).

Result: 14,4 [kW]

The actual power has to be recalculated when penstock and turbine plant are determined.

6. CIVIL WORKS

6.1 Weirs

To divert water to mills and power stations the water level has to be raised by weirs. Weirs may also serve for storage to meet peak demand.

If erected before water falls, in most cases, it is safe to base them on rock.

- > Care should be taken for safe bonding to prevent erosion.
- > A flush gate prevents settling of sand and may remain open in flood time.

(To safeguard stability the relation of base to height should be at least 3: 1)

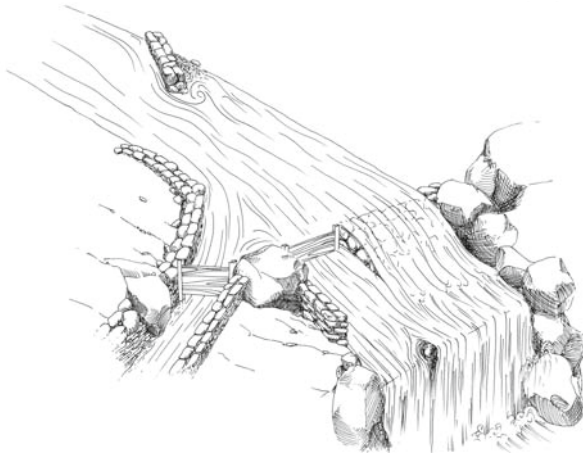
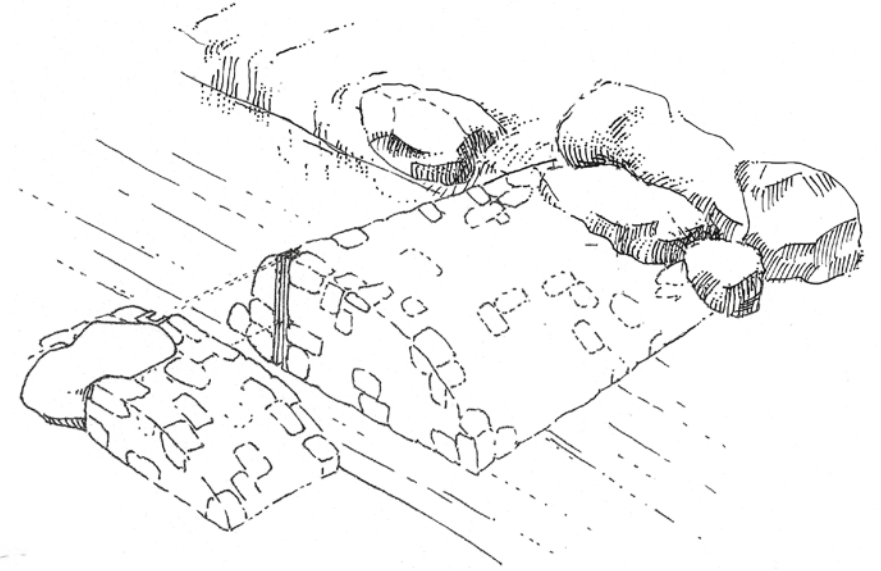
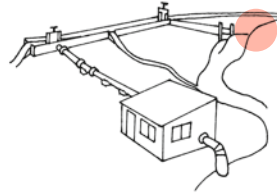

Simple rock fill *

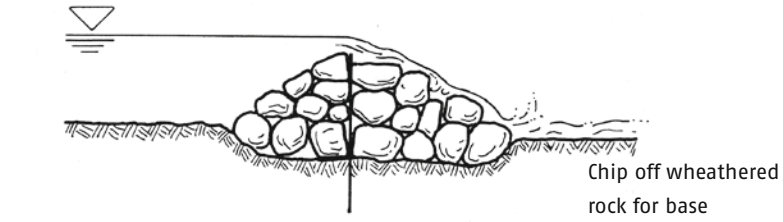

Gabion weir

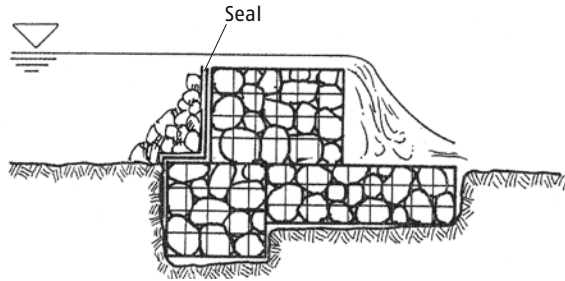

Natural stone mason work

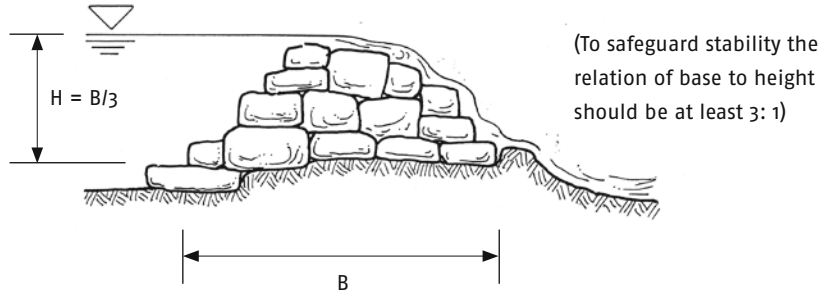

Concrete gravity weir

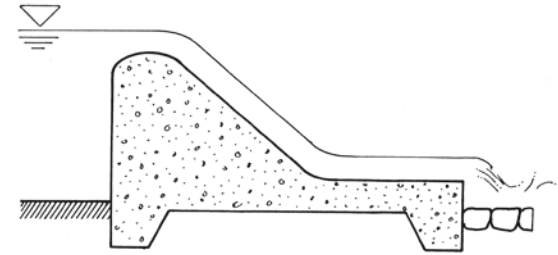

Tyrolean weir made with natural stones

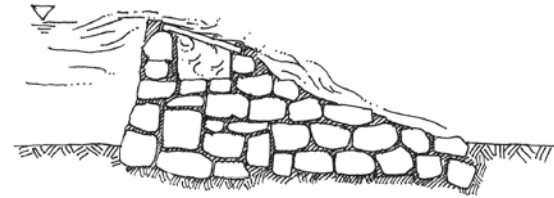

The great advantage: self cleaning screen

Secure with iron rod against sliding

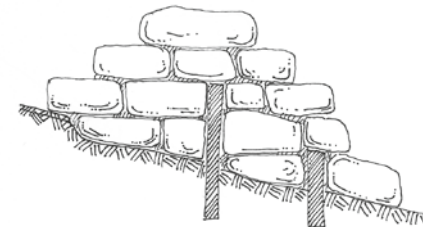

Stake weir

Often weirs are improvised using local material and have to be repaired or rebuilt after floods or the rainy season

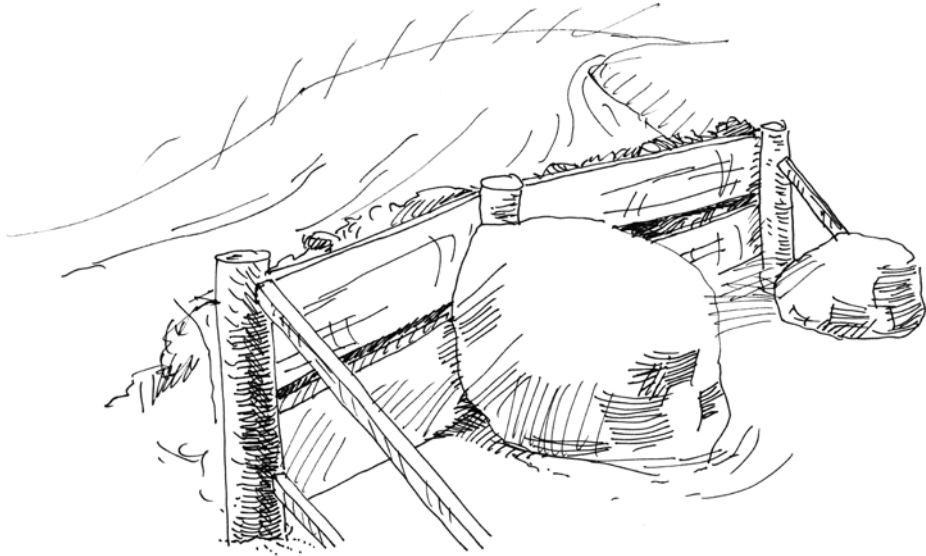

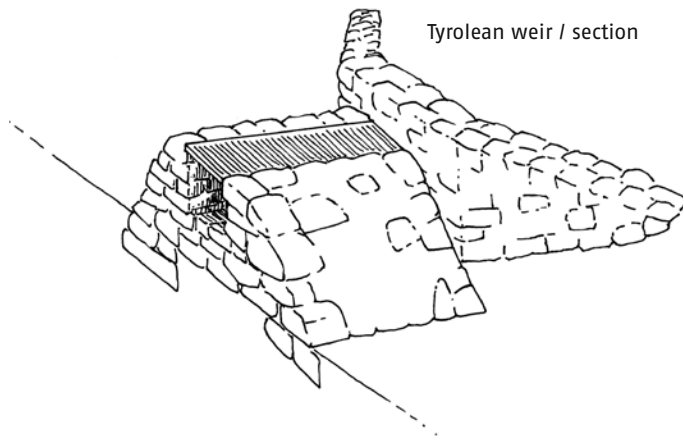

Tyrolean weir / section

Advantage: self cleaning screen

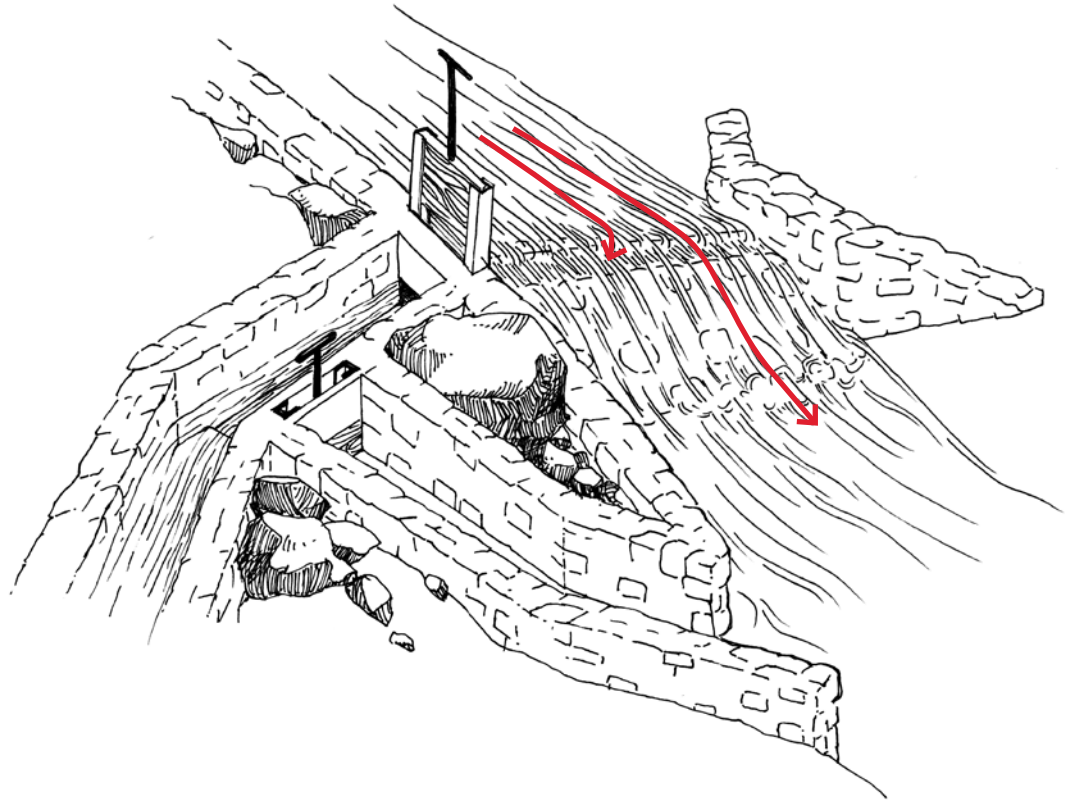

6.2 Intake

At the point where the water is diverted, solid matter, such as sand or gravel floating in the river, has to be abstracted to protect the turbine, avoid accumulation in the channel and protect the basins.

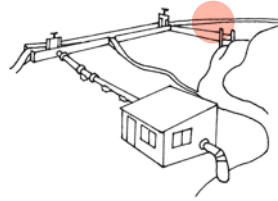

Structure of side intake with weir and flushing channel

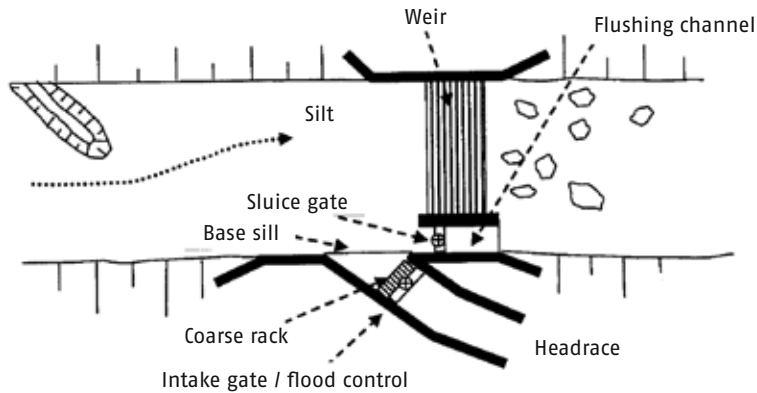

River diversion options / intake

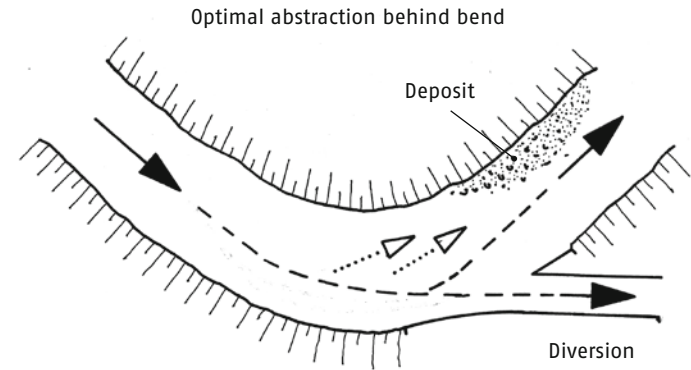

Side intake corrected with groin

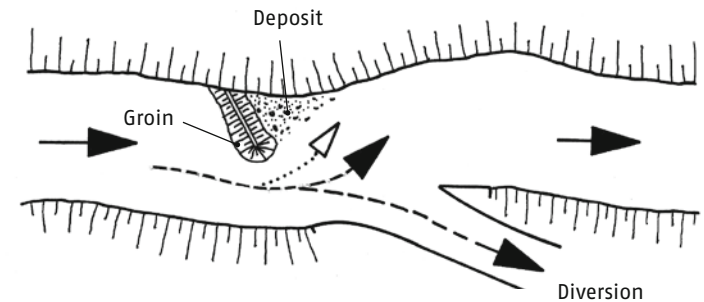

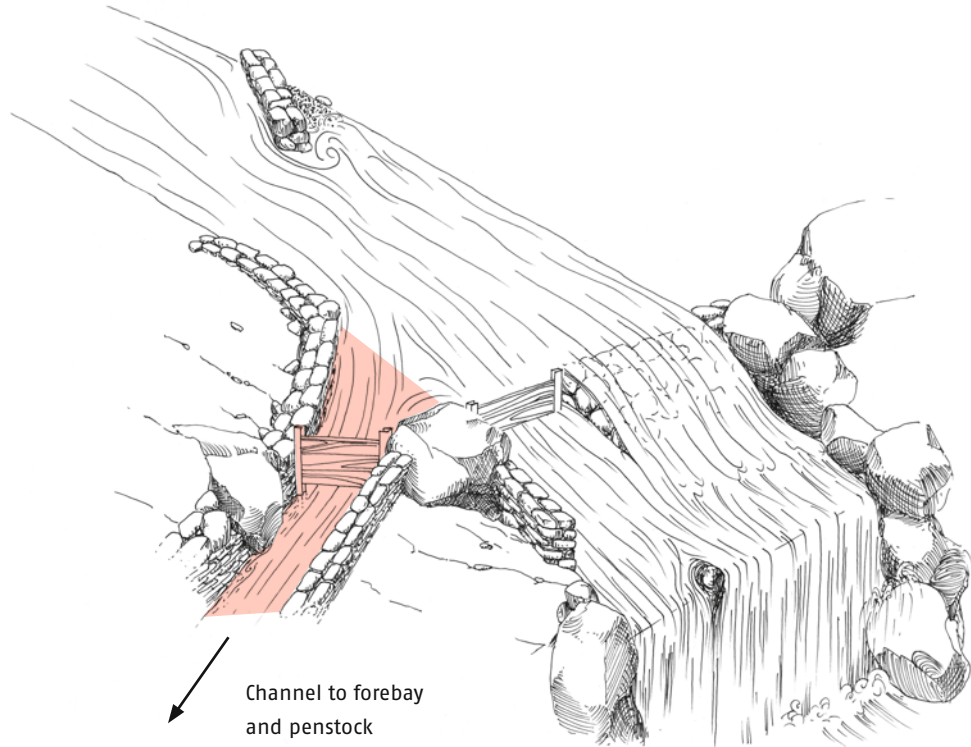

Channel to forebay and penstock

Often, if the penstock is close to a main waterfall, the water can be diverted at this point. In this case the rock structure in the diversion area has to be taken in to account when evaluating construction methods.

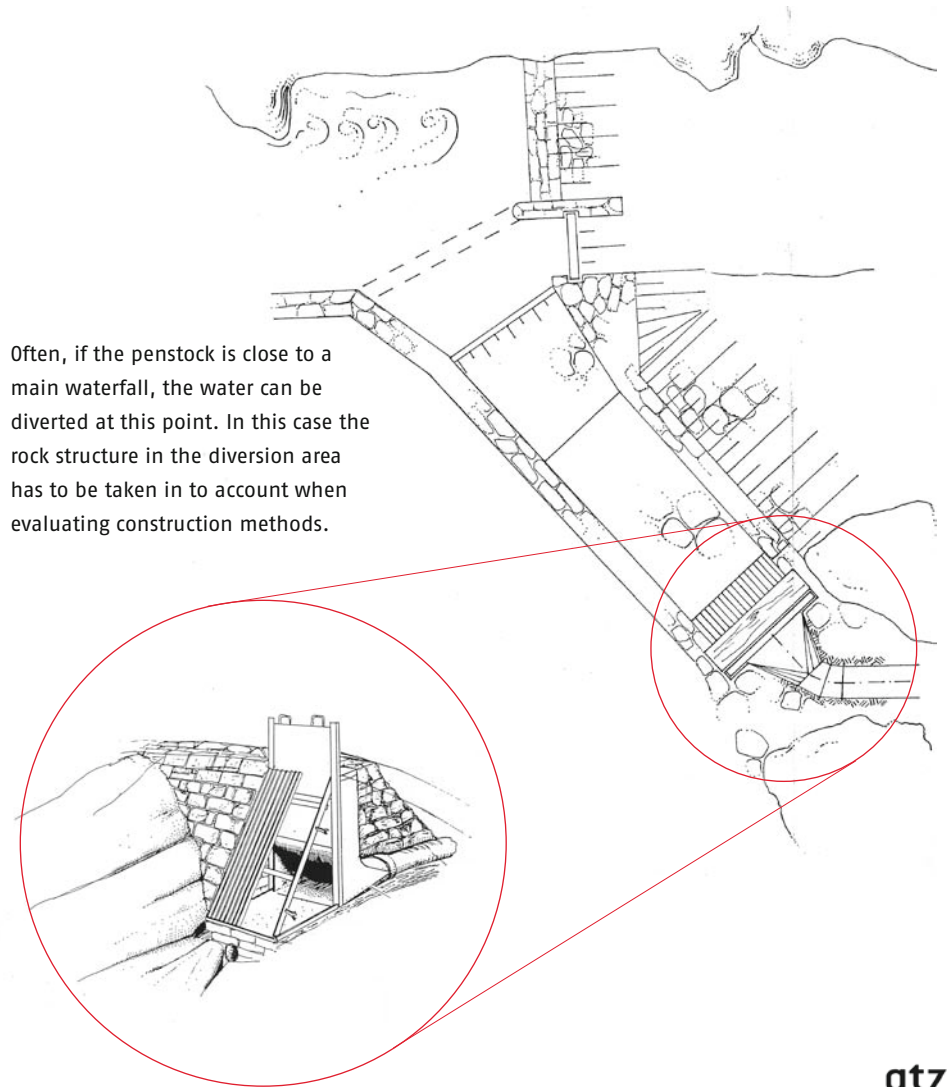

6.3 Channels

The type of head race depends on various conditions (stiffness, soil, landscape, crossings, etc.). Consider them carefully when determining the head race of your plant.

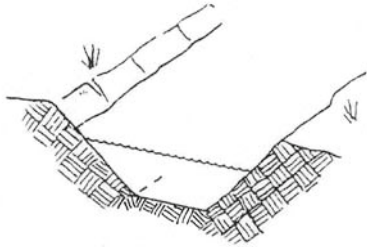
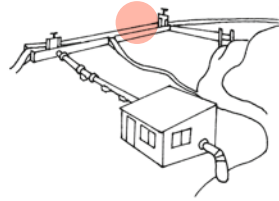

Excavate in natural
Impermeable soil, i.e. clay, must not
allow seepage

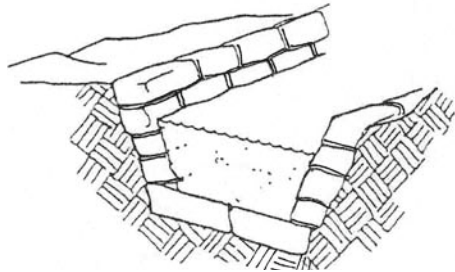

Lined channel with natural
stones, plates or bricks with
cement pointing

Concrete lining in dug-out
channel. Preferably made with
master section

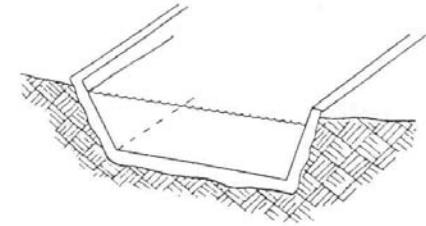

Concrete channels can have differ-
ent shapes, preferably trapezoid or
rectangular. They are commonly
used in difficult terrain and where
technology is used for road drains
and irrigation channels.

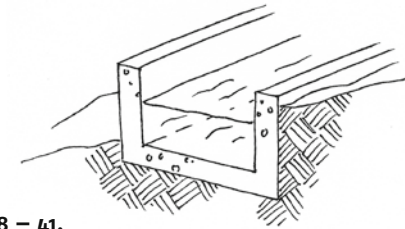
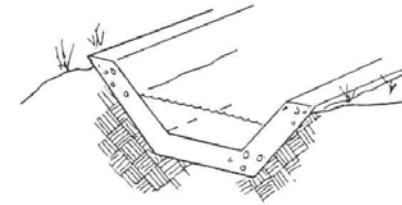

**For dimensioning refer to pages 38 – 41.
Charts for selection of shape and slope
according to flow.**

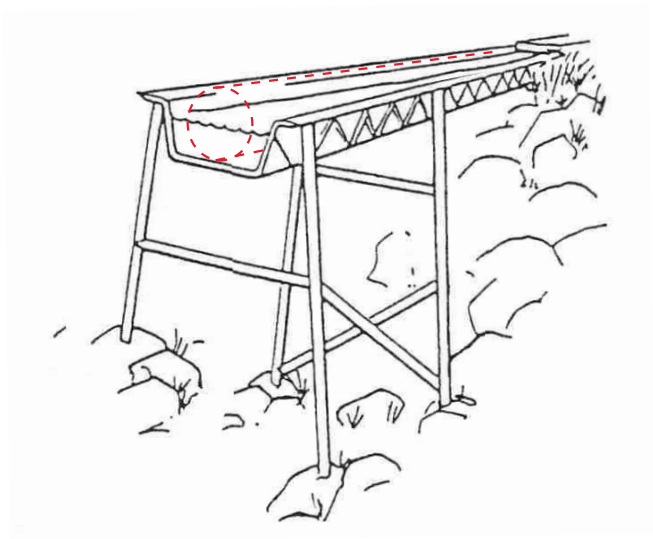
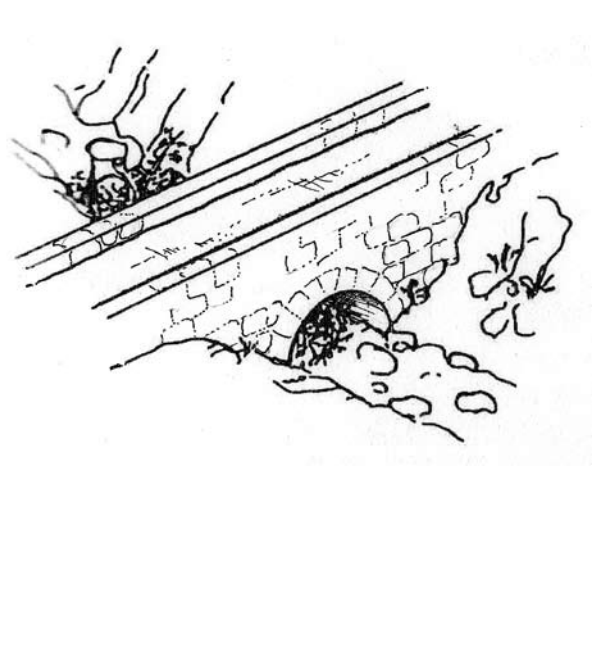
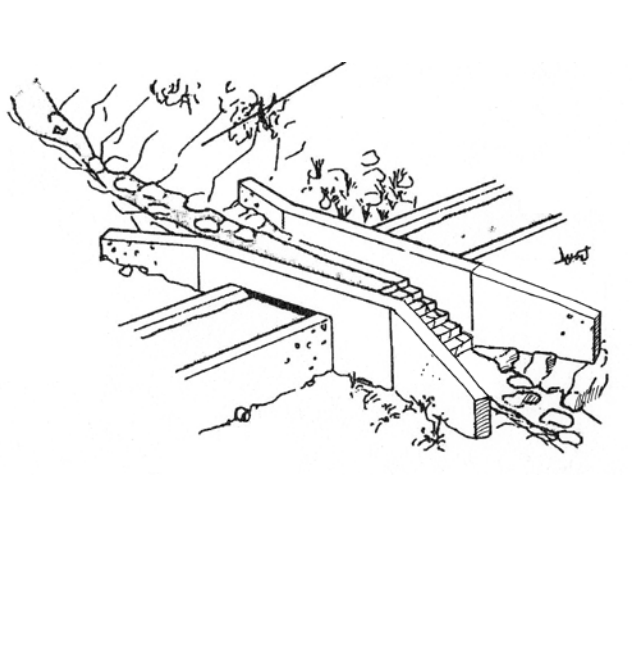

The above examples taken from the »Micro Hydro Design Manual« indicate that to find the best solution local designers and craftsmen have to apply skill and imagination.

Typical earth channel built on slope, using "road building" experience of local communities.

1. Prepare "road" along contour line (i.e. slope: according to channel dimensioning, see chapter 6.4 / 6.5)

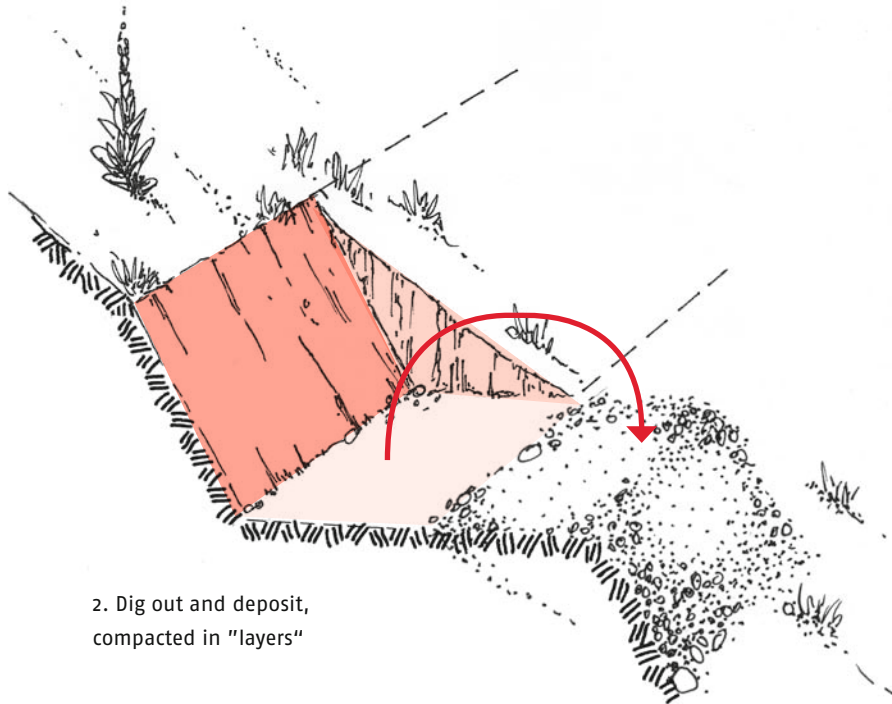

2. Dig out and deposit, compacted in "layers"

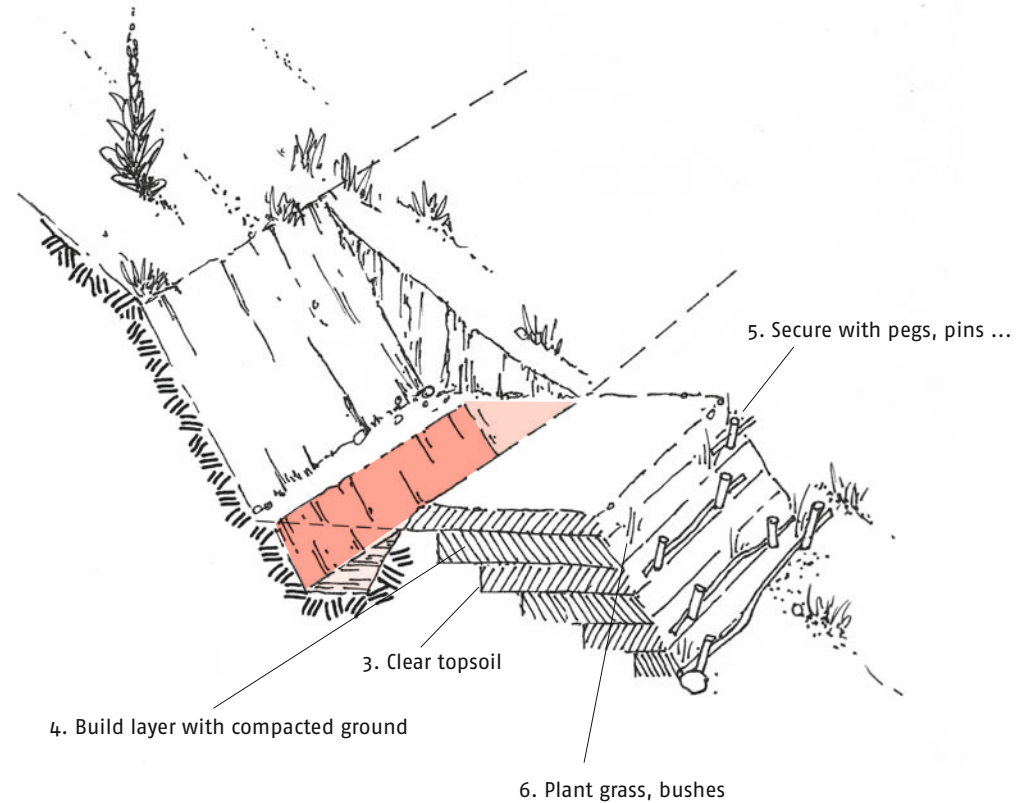

Channel built on rock

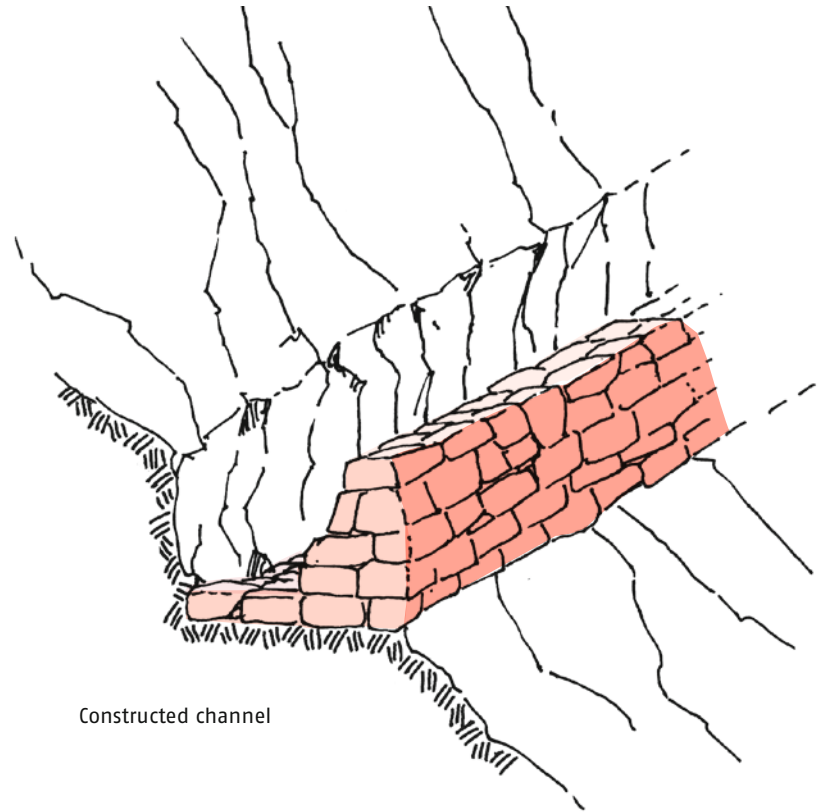
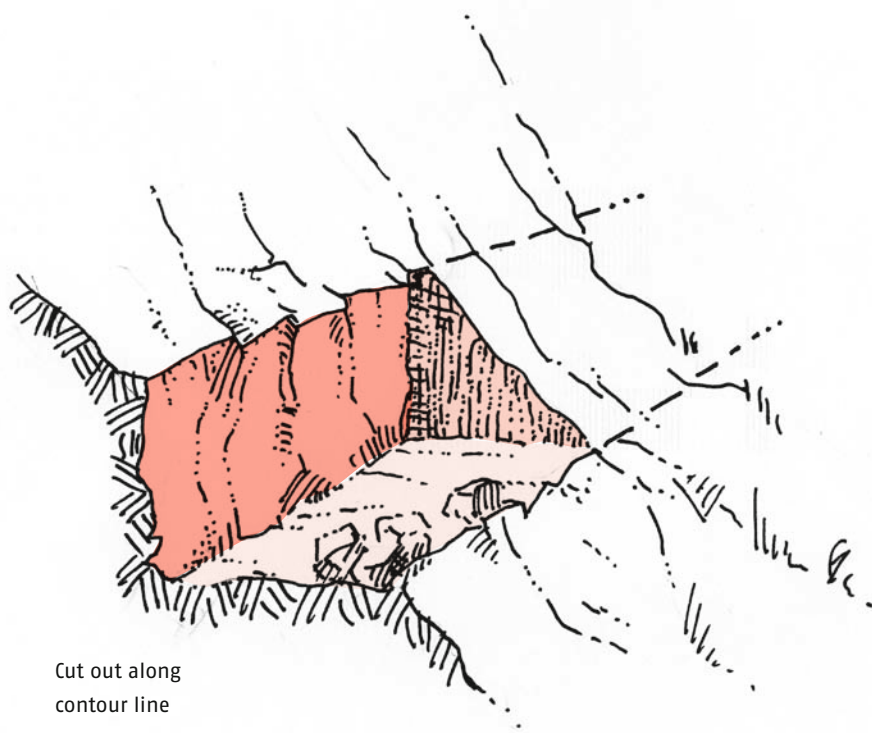

6.4 Discharge calculation for a straight rectangular channel in concrete or plastered mason work (roughness coefficient 40)

To calculate discharge of a straight rectangular channel (without tailback) made of concrete surface or plastered mason work, apply the Manning Strickler Equation, by consulting the channel dimensioning table (page 39).

The height includes the freeboard allowance with a factor of 1,3

Q = discharge [l/s]

I = slope [m/km]

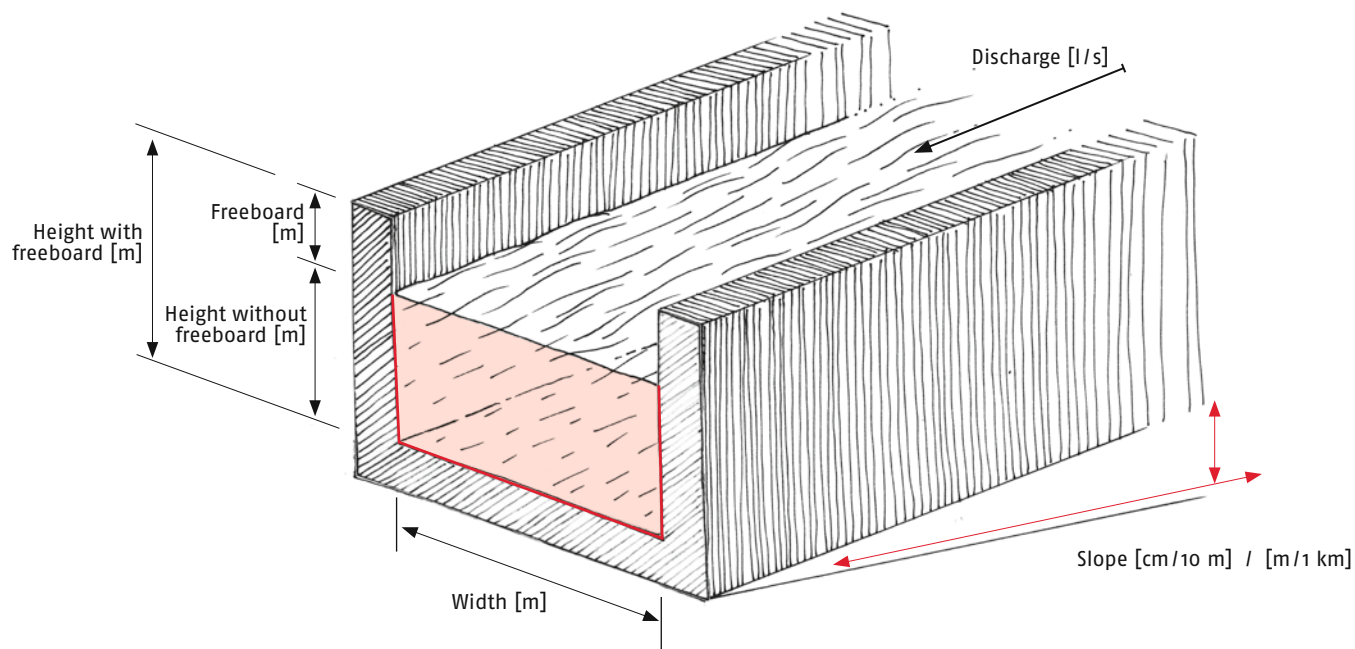

discharge [l/s]	width [m]	height [m]	slope [m/km]	discharge [l/s]	width [m]	height [m]	slope [m/km]	discharge [l/s]	width [m]	height [m]	slope [m/km]		discharge [l/s]	width [m]	height [m]	slope [m/km]
199	1,24	0,81	0,20	197	1,04	0,68	0,50	199	0,98	0,64	0,7		201	0,92	0,60	1,00
406	1,62	1,05	0,20	403	1,36	0,88	0,50	406	1,28	0,83	0,7		408	1,20	0,78	1,00
604	1,88	1,22	0,20	601	1,58	1,03	0,50	597	1,48	0,96	0,7		592	1,38	0,90	1,00
791	2,08	1,35	0,20	801	1,76	1,14	0,50	811	1,66	1,08	0,7		794	1,54	1,00	1,00
1011	2,28	1,48	0,20	1011	1,92	1,25	0,50	1007	1,80	1,17	0,7		1001	1,68	1,09	1,00
1211	2,44	1,59	0,20	1219	2,06	1,34	0,50	1196	1,92	1,25	0,7		1203	1,80	1,17	1,00
1405	2,58	1,68	0,20	1418	2,18	1,42	0,50	1406	2,04	1,33	0,7		1390	1,90	1,24	1,00
1587	2,70	1,76	0,20	1598	2,28	1,48	0,50	1597	2,14	1,39	0,7		1594	2,00	1,30	1,00
1816	2,84	1,85	0,20	1792	2,38	1,55	0,50	1804	2,24	1,46	0,7		1815	2,10	1,37	1,00
1991	2,94	1,91	0,20	2000	2,48	1,61	0,50	1981	2,32	1,51	0,7		2005	2,18	1,42	1,00
206	0,86	0,56	1,5	195	0,74	0,48	3,00	201	0,68	0,44	5,00		202	0,64	0,42	7,00
396	1,10	0,72	1,5	412	0,98	0,64	3,00	399	0,88	0,57	5,00		391	0,82	0,53	7,00
594	1,28	0,83	1,5	588	1,12	0,73	3,00	592	1,02	0,66	5,00		596	0,96	0,62	7,00
813	1,44	0,94	1,5	805	1,26	0,82	3,00	796	1,14	0,74	5,00		776	1,06	0,69	7,00
1006	1,56	1,01	1,5	987	1,36	0,88	3,00	996	1,24	0,81	5,00		986	1,16	0,75	7,00
1188	1,66	1,08	1,5	1193	1,46	0,95	3,00	1225	1,34	0,87	5,00		1179	1,24	0,81	7,00
1388	1,76	1,14	1,5	1328	1,52	0,99	3,00	1377	1,40	0,91	5,00		1392	1,32	0,86	7,00
1608	1,86	1,21	1,5	1626	1,64	1,07	3,00	1597	1,48	0,96	5,00		1629	1,40	0,91	7,00
1800	1,94	1,26	1,5	1790	1,70	1,11	3,00	1775	1,54	1,00	5,00		1822	1,46	0,95	7,00
2004	2,02	1,31	1,5	2023	1,78	1,16	3,00	2032	1,62	1,05	5,00		2028	1,52	0,99	7,00
203	0,60	0,39	10	203	0,58	0,38	12	207	0,56	0,36	15		196	0,52	0,34	20
409	0,78	0,51	10	390	0,74	0,48	12	405	0,72	0,47	15		401	0,68	0,44	20
599	0,90	0,59	10	618	0,88	0,57	12	611	0,84	0,55	15		619	0,80	0,52	20
794	1,00	0,65	10	824	0,98	0,64	12	824	0,94	0,61	15		798	0,88	0,57	20
1023	1,10	0,72	10	1016	1,06	0,69	12	1025	1,02	0,66	15		1007	0,96	0,62	20
1023	1,10	0,72	10	1176	1,12	0,73	12	1194	1,08	0,70	15		1183	1,02	0,66	20
1409	1,24	0,81	10	1414	1,20	0,78	12	1379	1,14	0,74	15		1378	1,08	0,70	20
1598	1,30	0,85	10	1610	1,26	0,82	12	1581	1,20	0,78	15		1592	1,14	0,74	20
1802	1,36	0,88	10	1823	1,32	0,86	12	1800	1,26	0,82	15		1825	1,20	0,78	20
2022	1,42	0,92	10	1974	1,36	0,68	12	2038	1,32	0,66	15		1992	1,24	0,62	20

6.5 Discharge calculation for a straight trapezoid channel in natural stone masonry or rough concrete (roughness coefficient 60)

To calculate discharge of a straight trapezoid channel (without tailback) made of natural stone work or with a rough concrete surface, apply the Manning Strickler Equation, by consulting the channel dimensioning table (page 41).

The height includes the freeboard allowance with a factor of 1,4.

Trapezoid channels are preferred when working with stone masonry, natural plates or pre-manufactured plates.

Q = discharge [l/s]

I = slope [m/km]

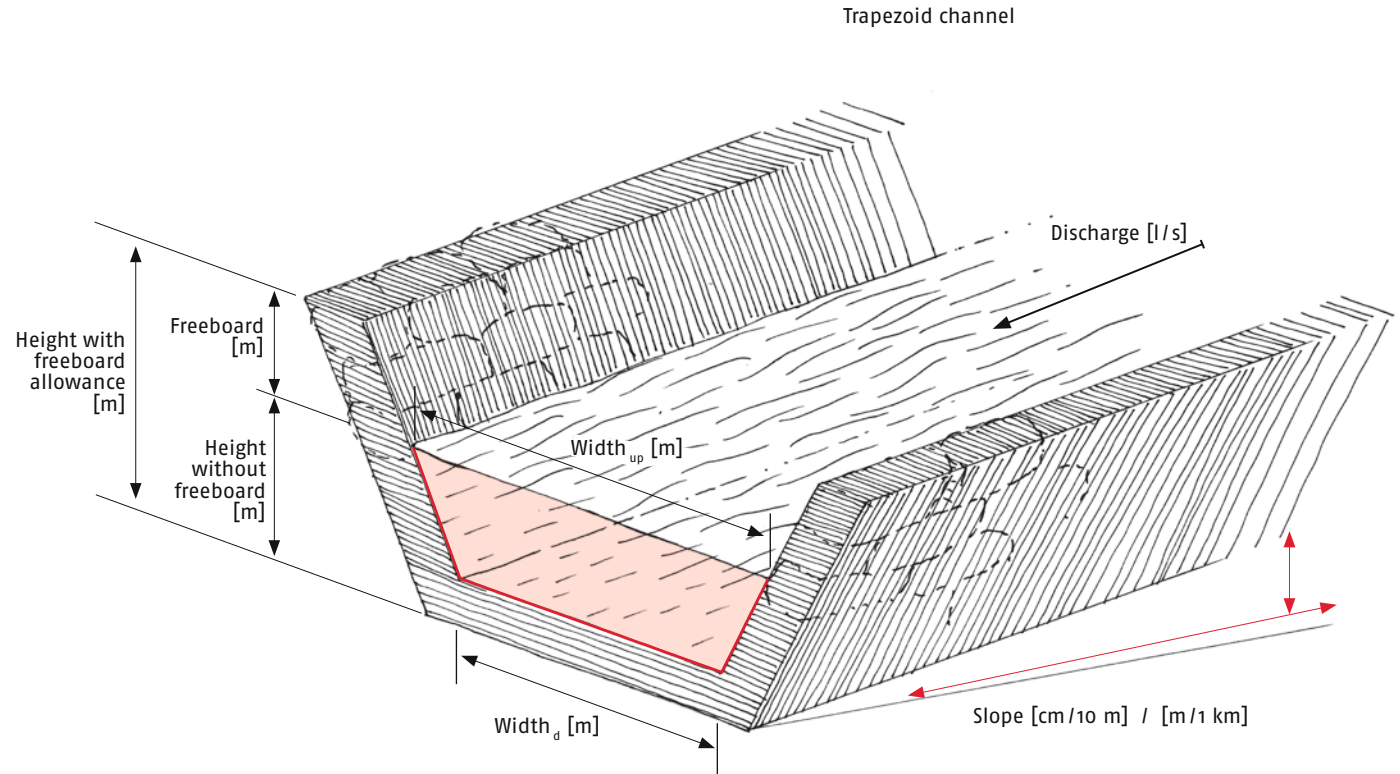

discharge [l/s]	width [m]		height [m]	slope [m/km]	discharge [l/s]	width [m]		height [m]	slope [m/km]	discharge [l/s]	width [m]		height [m]	slope [m/km]	discharge [l/s]	width [m]		height [m]	slope [m/km]
	down	up				down	up				down	up				down	up		
19	0,40	0,587	0,28	0,20	19	0,34	0,499	0,24	0,50	19	0,32	0,469	0,22	0,7	19	0,30	0,440	0,21	1,00
28	0,46	0,681	0,33	0,20	28	0,39	0,577	0,28	0,50	28	0,37	0,544	0,26	0,7	28	0,35	0,508	0,24	1,00
39	0,53	0,776	0,37	0,20	39	0,45	0,655	0,31	0,50	40	0,42	0,619	0,30	0,7	40	0,39	0,577	0,28	1,00
53	0,59	0,870	0,42	0,20	53	0,50	0,733	0,35	0,50	54	0,47	0,694	0,33	0,7	54	0,44	0,645	0,31	1,00
70	0,66	0,965	0,46	0,20	70	0,55	0,812	0,39	0,50	72	0,52	0,769	0,37	0,7	70	0,49	0,714	0,34	1,00
90	0,72	1,059	0,51	0,20	89	0,61	0,890	0,42	0,50	92	0,58	0,844	0,40	0,7	89	0,53	0,782	0,37	1,00
113	0,79	1,154	0,55	0,20	112	0,66	0,968	0,46	0,50	115	0,63	0,919	0,44	0,7	112	0,58	0,851	0,41	1,00
139	0,85	1,248	0,60	0,20	137	0,71	1,046	0,50	0,50	142	0,68	0,994	0,47	0,7	138	0,63	0,919	0,44	1,00
169	0,92	1,343	0,64	0,20	166	0,77	1,124	0,54	0,50	172	0,73	1,069	0,51	0,7	167	0,67	0,988	0,47	1,00
203	0,98	1,437	0,69	0,20	199	0,82	1,203	0,57	0,50	206	0,78	1,144	0,55	0,7	199	0,72	1,056	0,50	1,00
20	0,28	0,411	0,20	1,50	18	0,24	0,352	0,17	3,00	19	0,22	0,323	0,15	5,00	22	0,22	0,323	0,15	7,00
29	0,32	0,476	0,23	1,50	28	0,28	0,411	0,20	3,00	28	0,26	0,375	0,18	5,00	32	0,25	0,368	0,18	7,00
41	0,37	0,541	0,26	1,50	40	0,32	0,469	0,22	3,00	40	0,29	0,427	0,20	5,00	43	0,28	0,414	0,20	7,00
56	0,41	0,606	0,29	1,50	54	0,36	0,528	0,25	3,00	54	0,33	0,479	0,23	5,00	57	0,31	0,460	0,22	7,00
73	0,46	0,671	0,32	1,50	72	0,40	0,587	0,28	3,00	71	0,36	0,531	0,25	5,00	74	0,34	0,505	0,24	7,00
93	0,50	0,737	0,35	1,50	93	0,44	0,645	0,31	3,00	92	0,40	0,583	0,28	5,00	93	0,38	0,551	0,26	7,00
117	0,55	0,802	0,38	1,50	117	0,48	0,704	0,34	3,00	115	0,43	0,636	0,30	5,00	115	0,41	0,596	0,28	7,00
144	0,59	0,867	0,41	1,50	145	0,52	0,763	0,36	3,00	142	0,47	0,688	0,33	5,00	140	0,44	0,642	0,31	7,00
175	0,64	0,932	0,44	1,50	176	0,56	0,821	0,39	3,00	172	0,50	0,740	0,35	5,00	168	0,47	0,688	0,33	7,00
209	0,68	0,997	0,48	1,50	212	0,60	0,880	0,42	3,00	207	0,54	0,792	0,38	5,00	199	0,50	0,733	0,35	7,00
21	0,20	0,293	0,14	10,00	17	0,18	0,264	0,13	12,00	19	0,18	0,264	0,13	15,00	22	0,18	0,264	0,13	20,00
30	0,23	0,339	0,16	10,00	26	0,21	0,310	0,15	12,00	28	0,21	0,306	0,15	15,00	32	0,21	0,303	0,14	20,00
43	0,26	0,385	0,18	10,00	38	0,24	0,355	0,17	12,00	40	0,24	0,349	0,17	15,00	44	0,23	0,342	0,16	20,00
57	0,29	0,430	0,21	10,00	52	0,27	0,401	0,19	12,00	55	0,27	0,391	0,19	15,00	59	0,26	0,381	0,18	20,00
75	0,32	0,476	0,23	10,00	69	0,30	0,447	0,21	12,00	72	0,30	0,433	0,21	15,00	76	0,29	0,420	0,20	20,00
96	0,36	0,521	0,25	10,00	90	0,34	0,492	0,23	12,00	92	0,32	0,476	0,23	15,00	97	0,31	0,460	0,22	20,00
120	0,39	0,567	0,27	10,00	114	0,37	0,538	0,26	12,00	116	0,35	0,518	0,25	15,00	120	0,34	0,499	0,24	20,00
147	0,42	0,613	0,29	10,00	142	0,40	0,583	0,28	12,00	143	0,38	0,561	0,27	15,00	147	0,37	0,538	0,26	20,00
179	0,45	0,658	0,31	10,00	173	0,43	0,629	0,30	12,00	173	0,41	0,603	0,29	15,00	178	0,39	0,577	0,28	20,00
214	0,48	0,704	0,34	10,00	209	0,46	0,675	0,32	12,00	207	0,44	0,645	0,31	15,00	212	0,42	0,616	0,29	20,00

6.6 Spillways

Spillways are required to

- > prevent flooding in channels
- > control channel flow
(if channels are long, spacing may be approx. 100 – 200 meters)
- > protect power plant near forebay
- > protect penstock and power plant

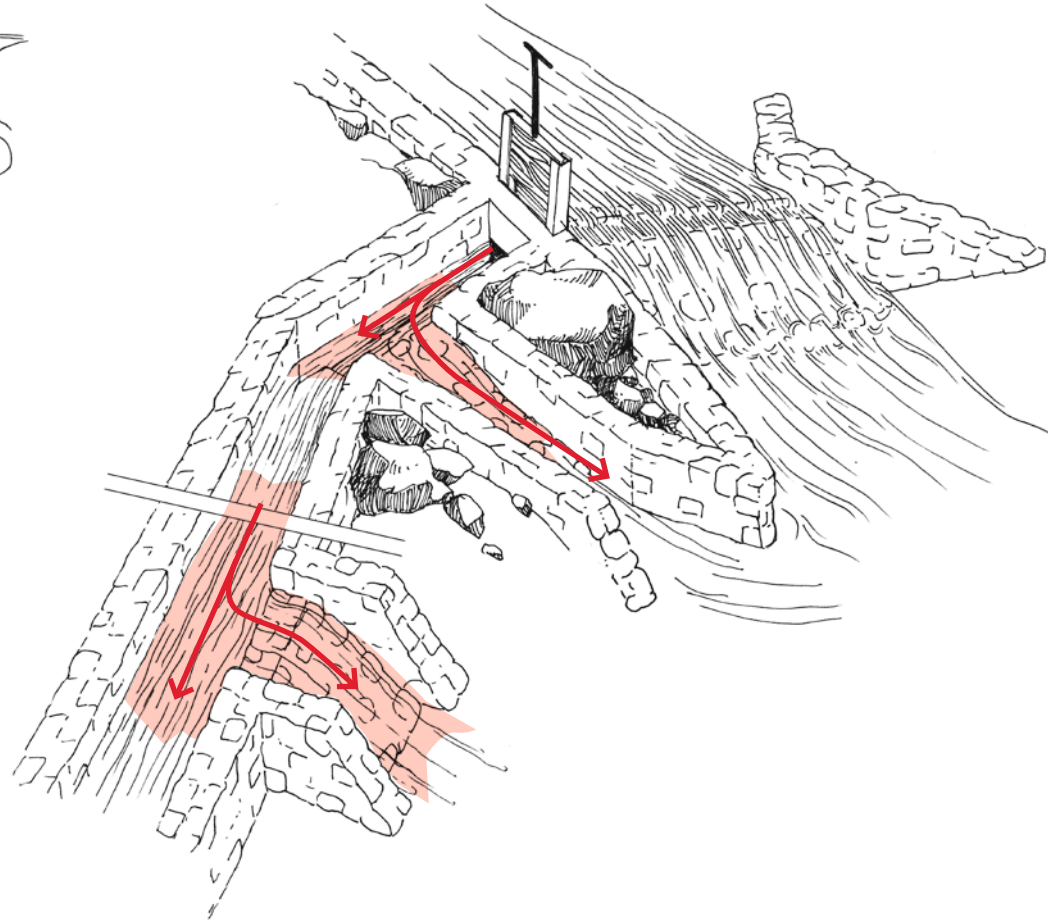
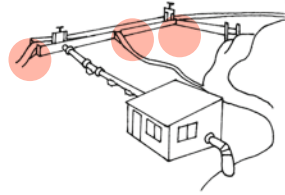

Spillway (head race) sections

Concrete structure

May be partly reinforced, depending on site conditions

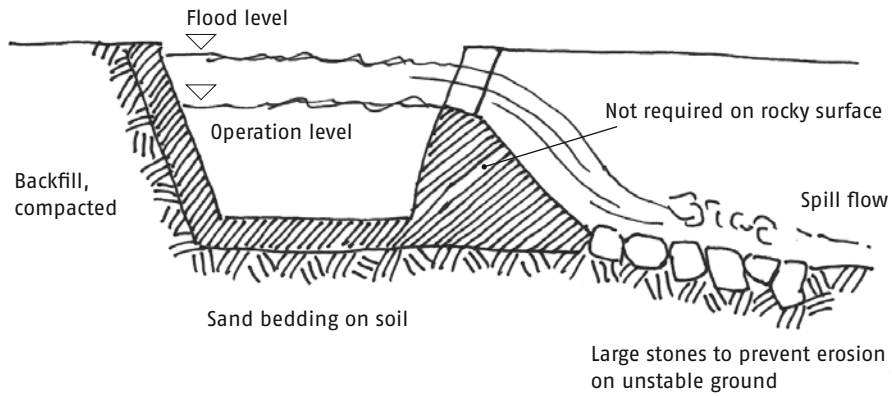

Natural stone

Masonry in cement mortar

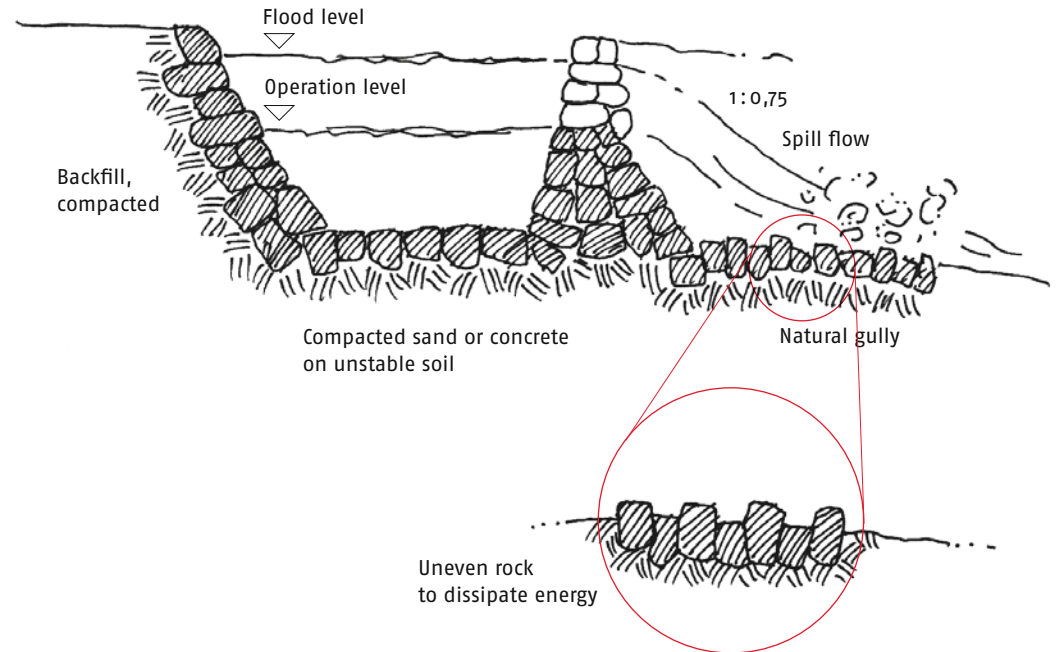

6.7 Forebay

Normally, the forebay is combined with a silt basin. Sometimes, for rivers with large bed load, it is necessary to interconnect a silt basin with the head race.

Components:

- > Flushing channel for deposits
- > Hand sliding gate to remove deposits (alternatively: cylindrical gate)
- > Penstock gate to regulate the inflow (only at forebay)
- > Spillway for a safe plant
- > Fine trashrack (optional for stand-alone silt basin)
- > Sill at the end of the sandtrap to prevent sand and gravel entering the adjacent penstock or head race
- > Longitudinal bed slope should not be less than 1:30

Make sure that you

- > avoid leakage through the forebay to prevent soil erosion
- > avoid leakage through the forebay headwall along penstock pipe by installing a puddle flange of rubber or mild steel material

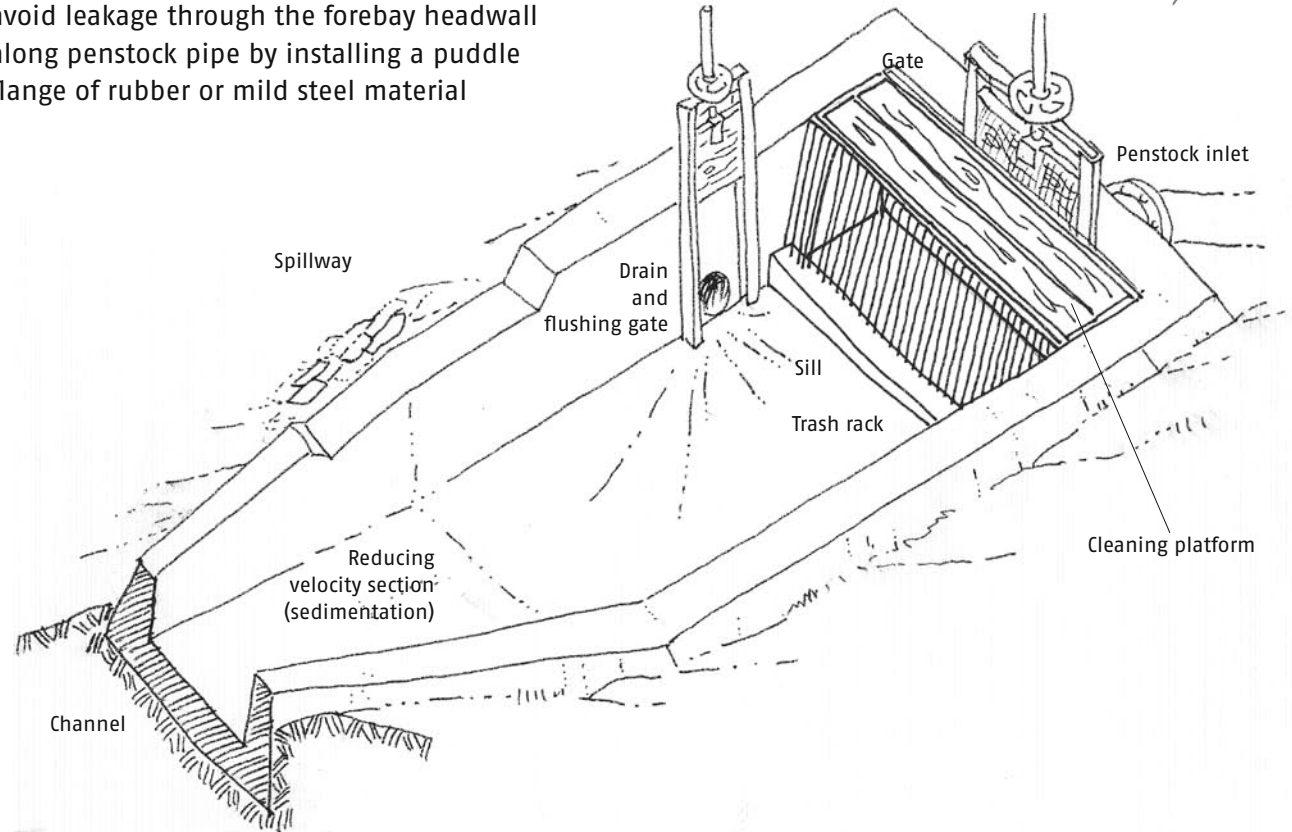

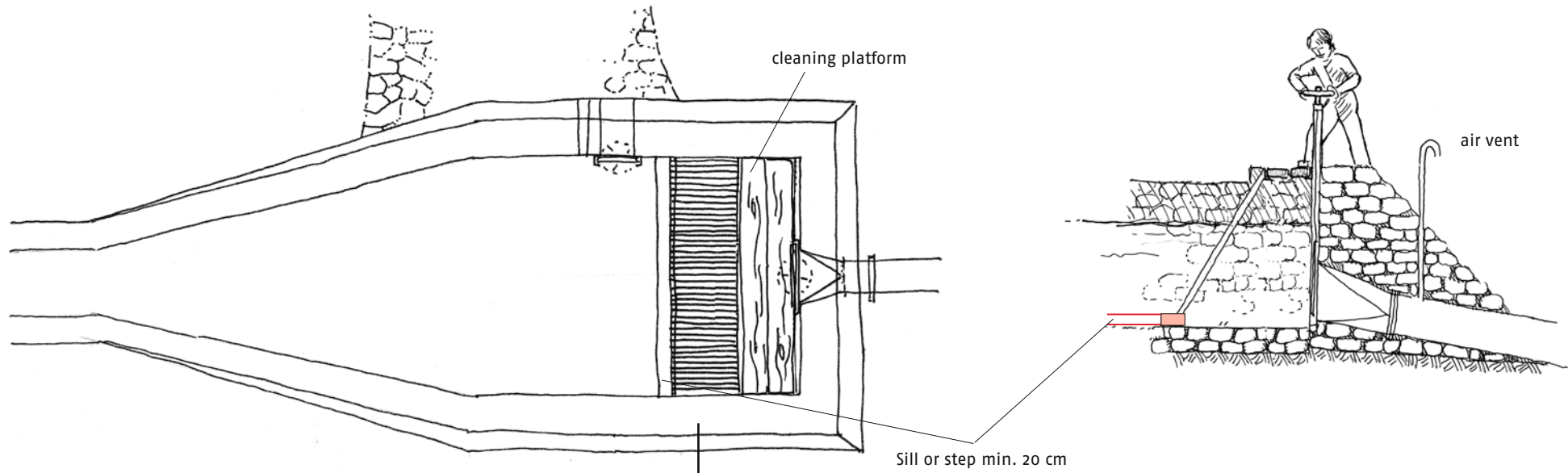

Option: penstock inlet sideways

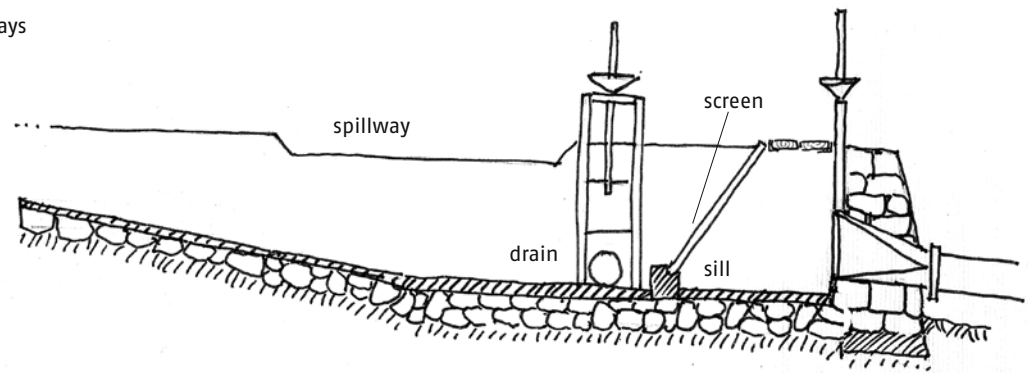

6.8 Penstock

The pressure pipe conveys water from forebay to power house.

Procedure:

- > Determine the route of the pipe. You need to look for straightness and safe underground. Avoid crossings, inaccessible terrain etc.
- > Pre-select diameter with friction loss chart (page 51):
Velocity 1.5 – 2.5 m/sec.
Friction loss < 5 – 10% max.
- > Calculate losses of bend, valves etc.
- > Choose locally available pipe material such as plastic, concrete etc., or go for – most commonly – locally manufactured steel pipes (see instruction).
- > Check final design data with selected optimized options.

Make sure that you

- > pay attention to support and anchoring (rule of thumb: for power >20 kW and high pressure: calculated)
- > consider thrust at bends, spacing of sliding pier not below 2.5 m (300 DIA), 3 m (400 DIA)
- > provide expansion joints between anchoring blocks
- > use flanges in appropriate distances, weld the rolled (2m) pipes together.

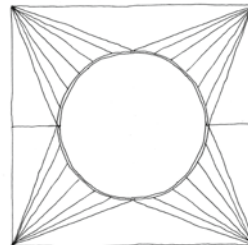
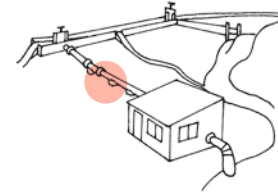

Penstock inlet preparing instructions

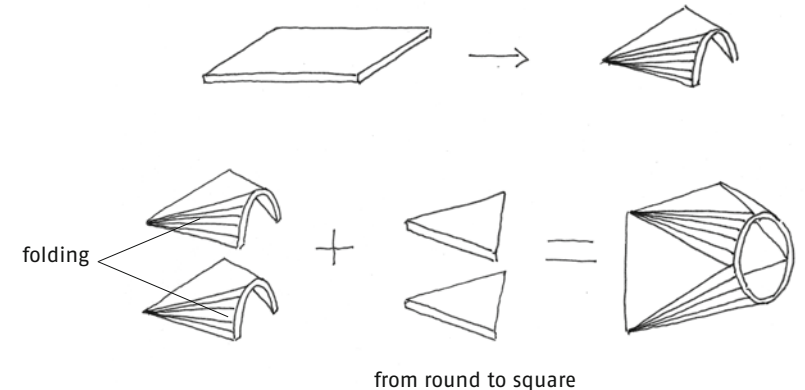

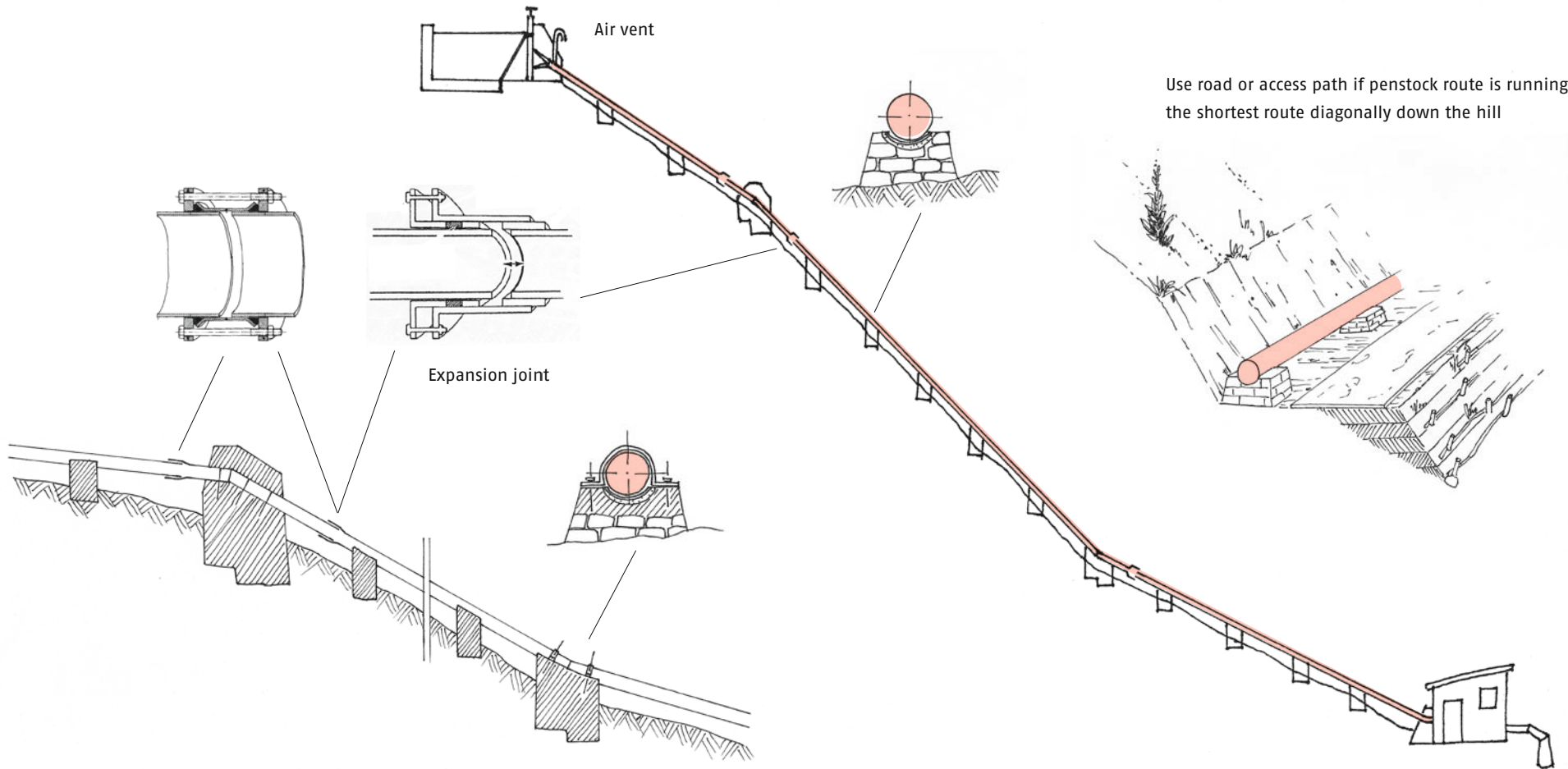

Use road or access path if penstock route is running the shortest route diagonally down the hill

6.9 Pipe manufacturing

Penstock pipes can be manufactured locally – even at site if the hand-operated sheet rolling machine is brought along.

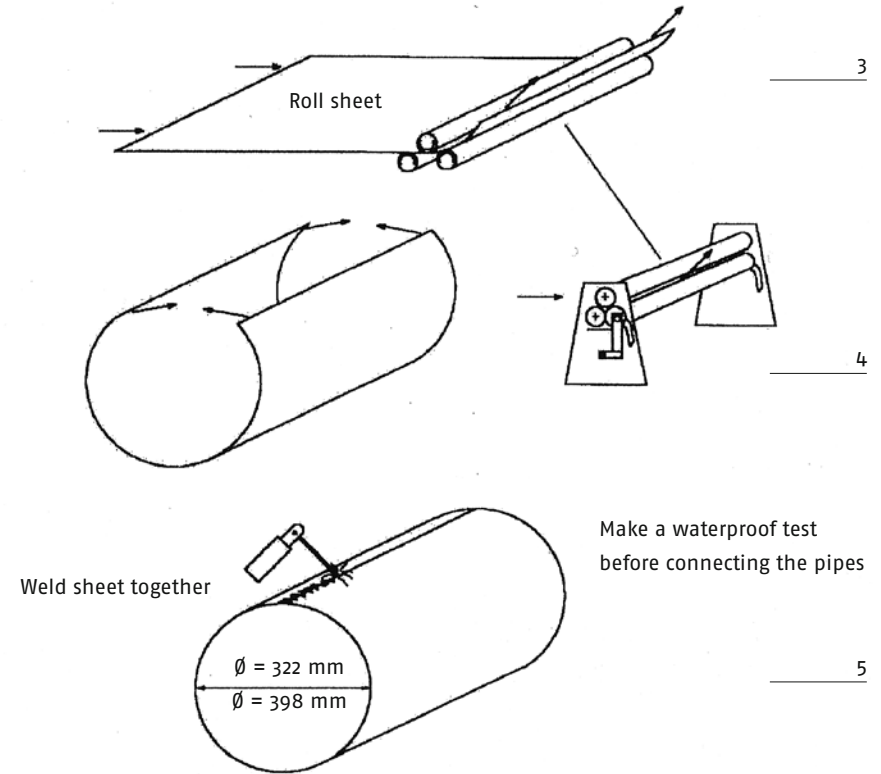
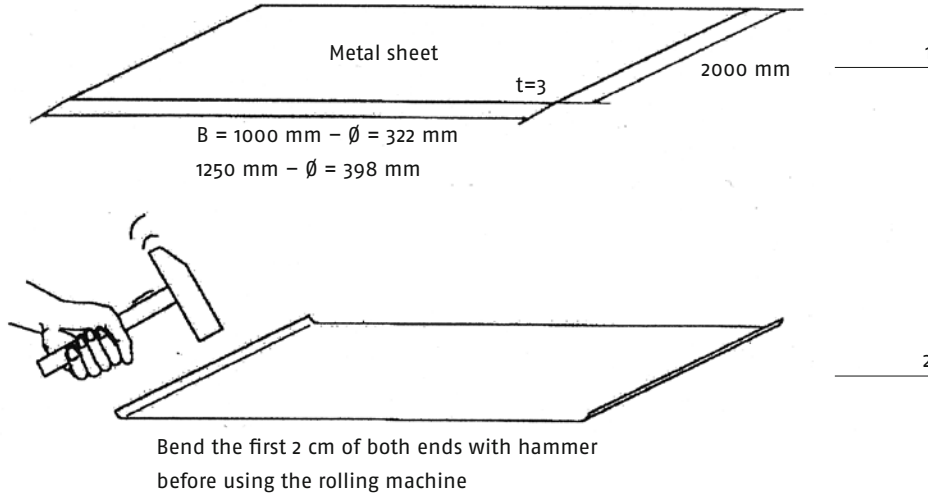

6.10 Flange Coupling

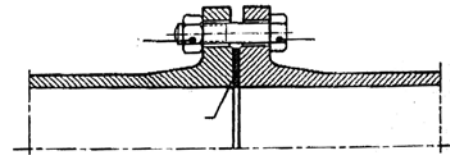

With flat gasket

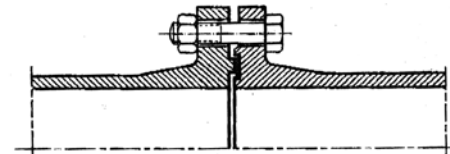

With groove and o-ring seal

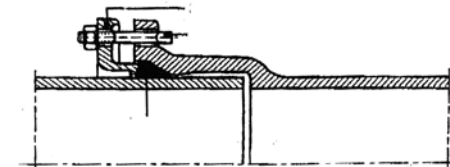

Locally manufactured: cheap

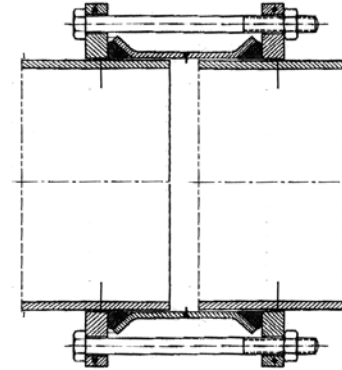

Type dresser: expensive

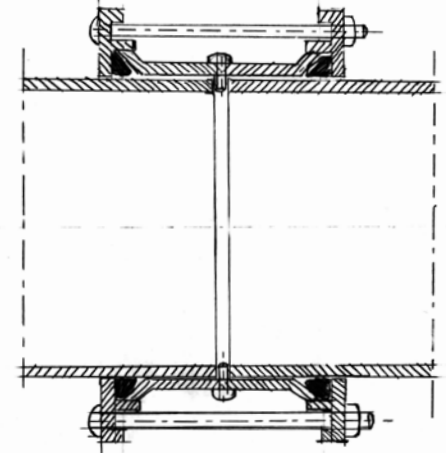

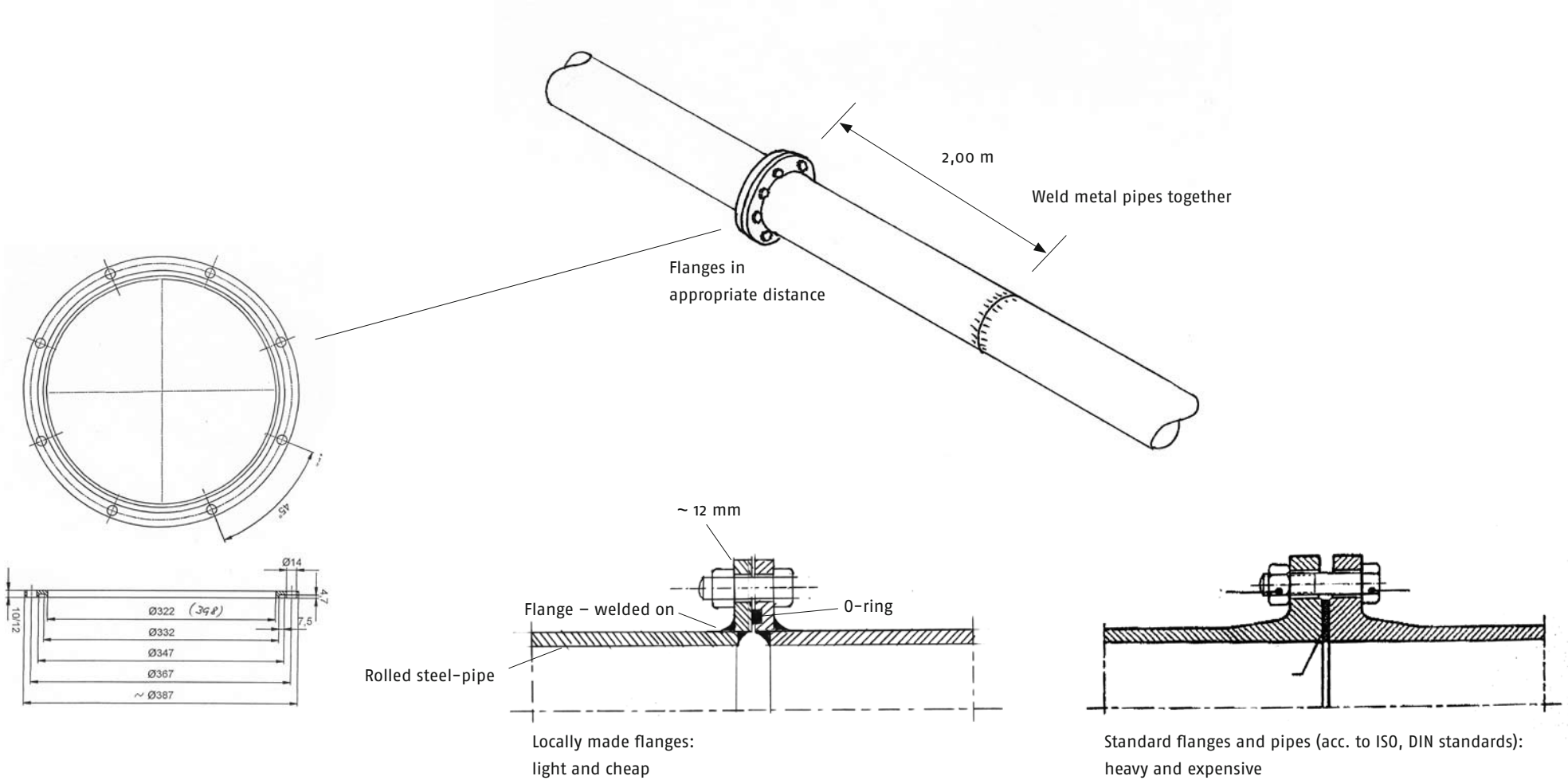

Selection of diameter / penstock losses

Loss [m/100 m]

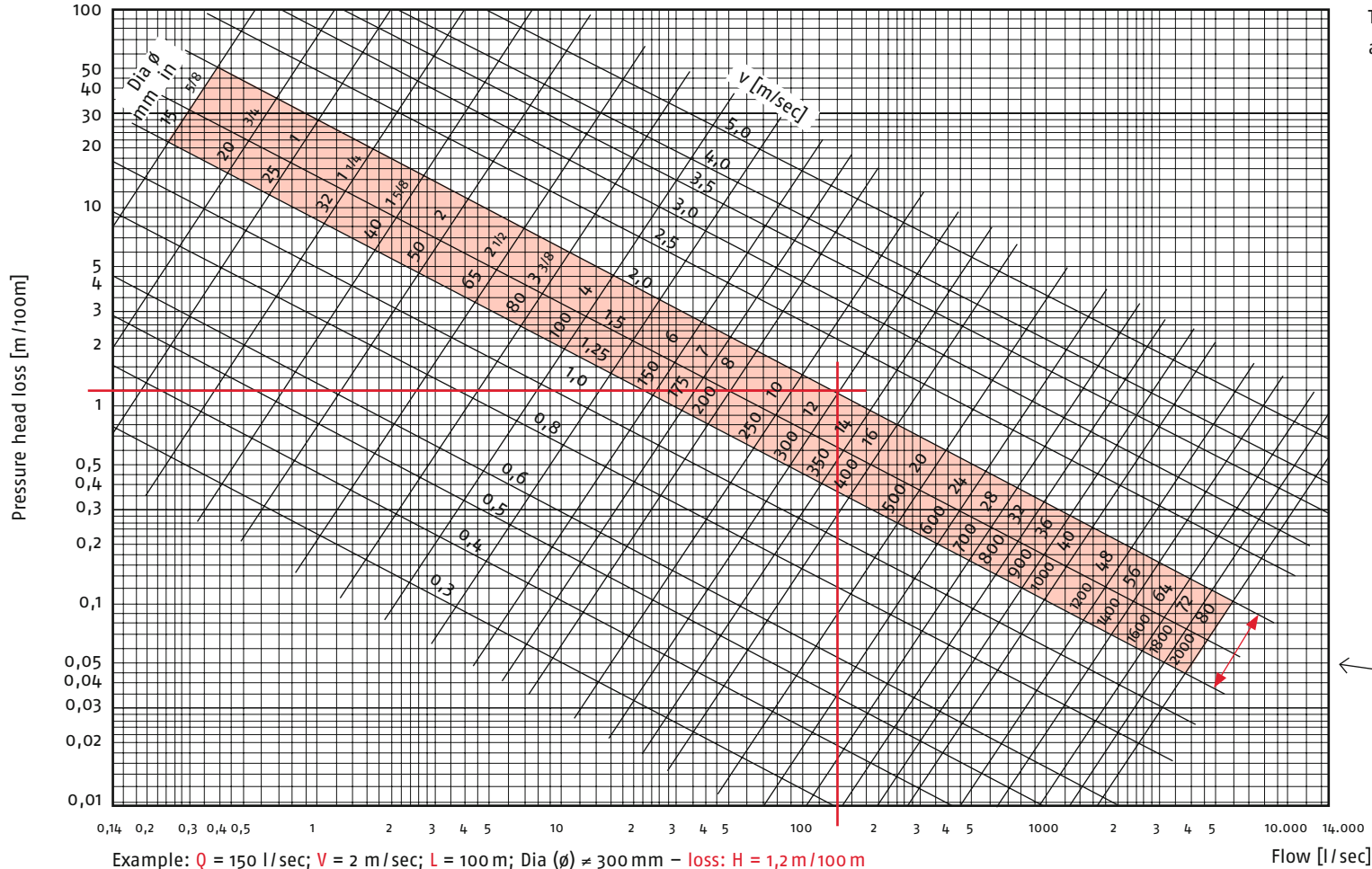

The losses in bends valve have to be added to penstock losses

← Preferred range

6.11 Power House

The power house has to be designed to the requirements of the turbine and its connections to the tail side:

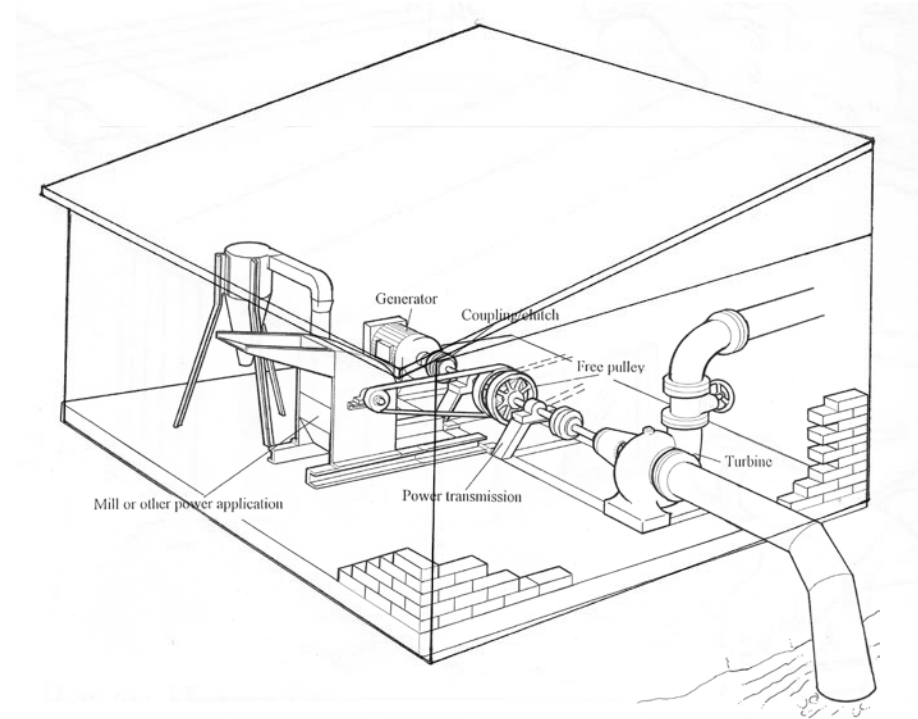
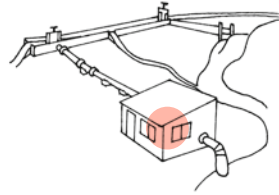

Reaction-turbines:

Francis turbines and PATs utilize the full head to tail water level

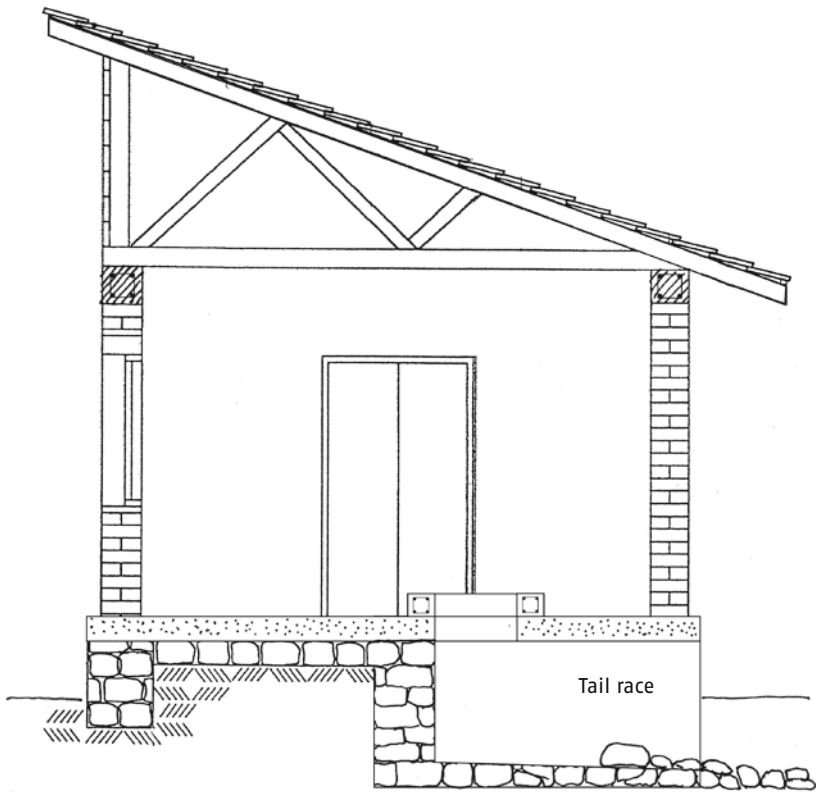

Construction example

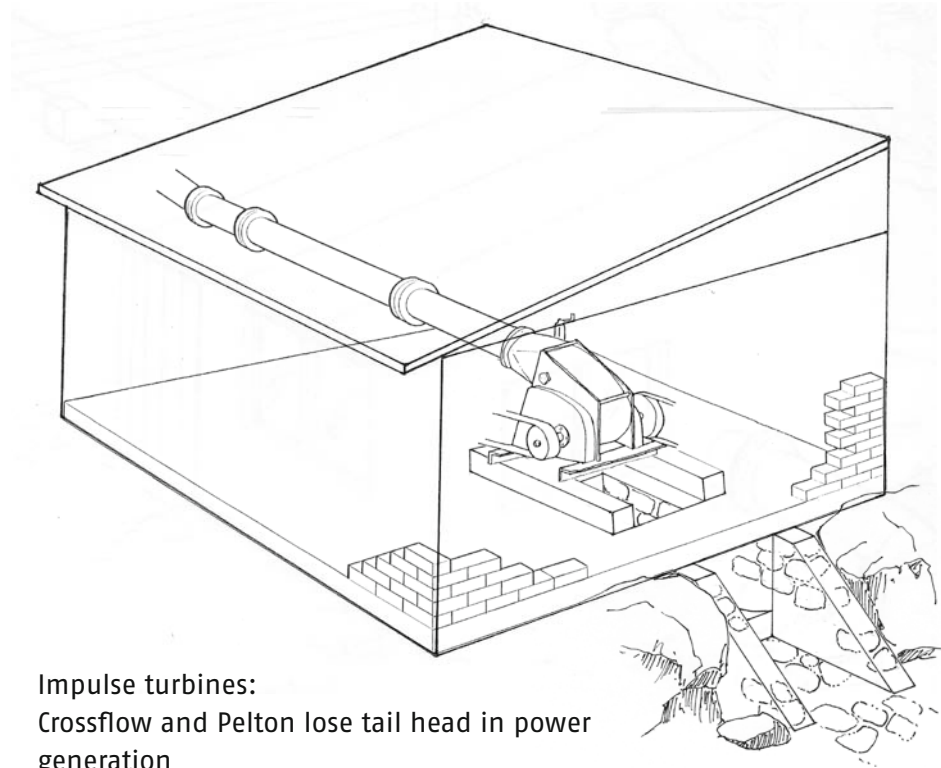

Impulse turbines:
Crossflow and Pelton lose tail head in power generation

Please note: The power house should be constructed on a level and base that is safe from flooding preferably on rock.
Flood diversion may have to be provided

6.12 Steel works – gates, screens

Gates are used to regulate the amount of water that is directed to the power house and to safeguard against damage of the plant in times of heavy rainfall.

Gates have to be installed at several points to fulfil different functions according to their location, such as:

- > spill control, at weir and silt basin
- > flood control, channel inlet
- > stop log, for maintenance
- > discharge, regulation forebay
- > etc.

If possible, take common gates, such as are used e.g. for irrigation

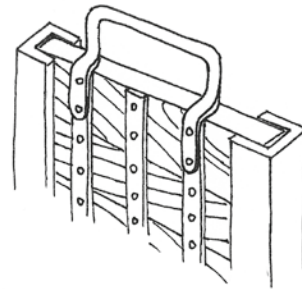
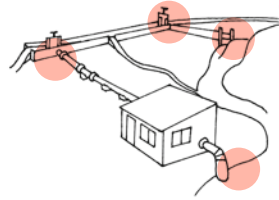

Wood

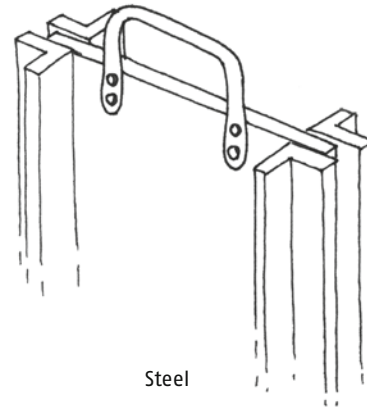

Steel

Simple hand sliding gate, e.g. flushing channel

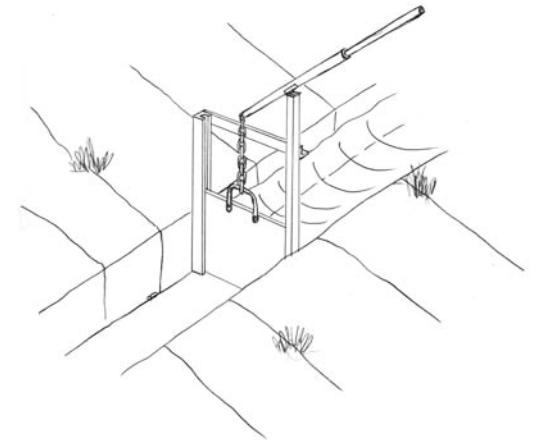

Channel sliding gate, fitted with long lever as a hoisting device

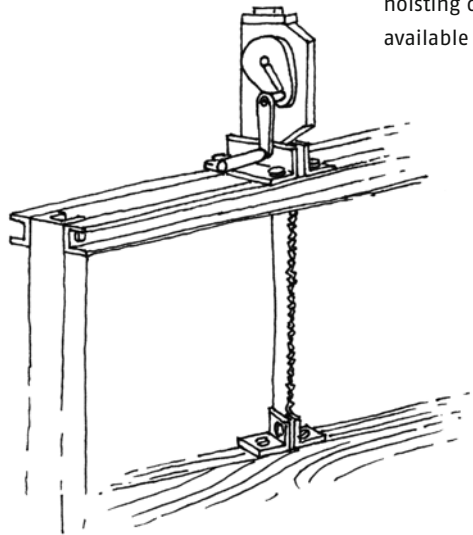

Sliding gate with mechanical hoisting device. Use locally available lifting devices

Sliding gate fitted with spindle

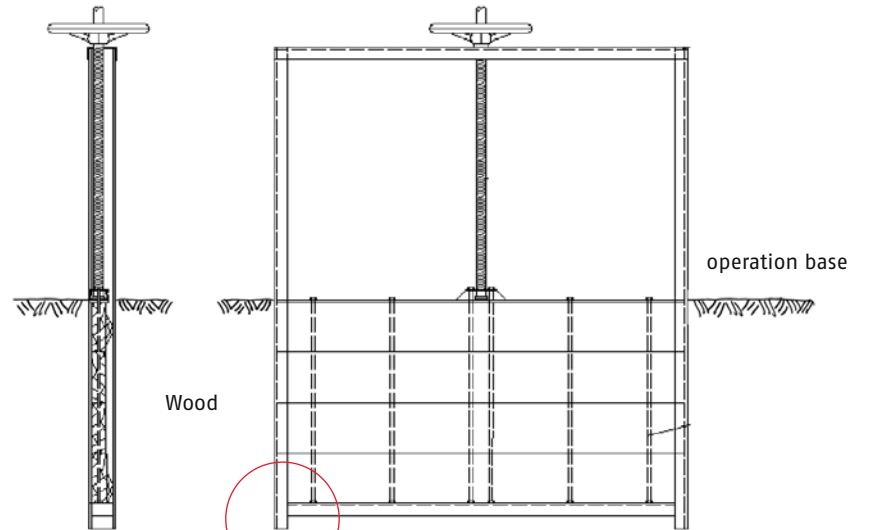

Sealing with wood

U-channel

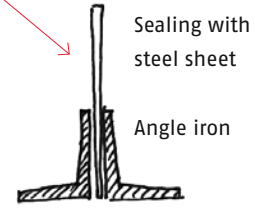

5 + (2 mm)

6.13 Trash rack

Coarse trash racks may be provided at intakes and upstream of head races.

Fine trash racks have to be fixed in front of a penstock to avoid damage of the penstock and turbine plant.

The trash rack construction should be installed along the whole width of the flow area of a channel or bay for ease of cleaning.

- > Dimension size of trash rack big enough; velocity of water should not exceed 0,5 m/sec.
- > Spacing of bars 20 to 25 mm – but always smaller than passage of turbine vanes.

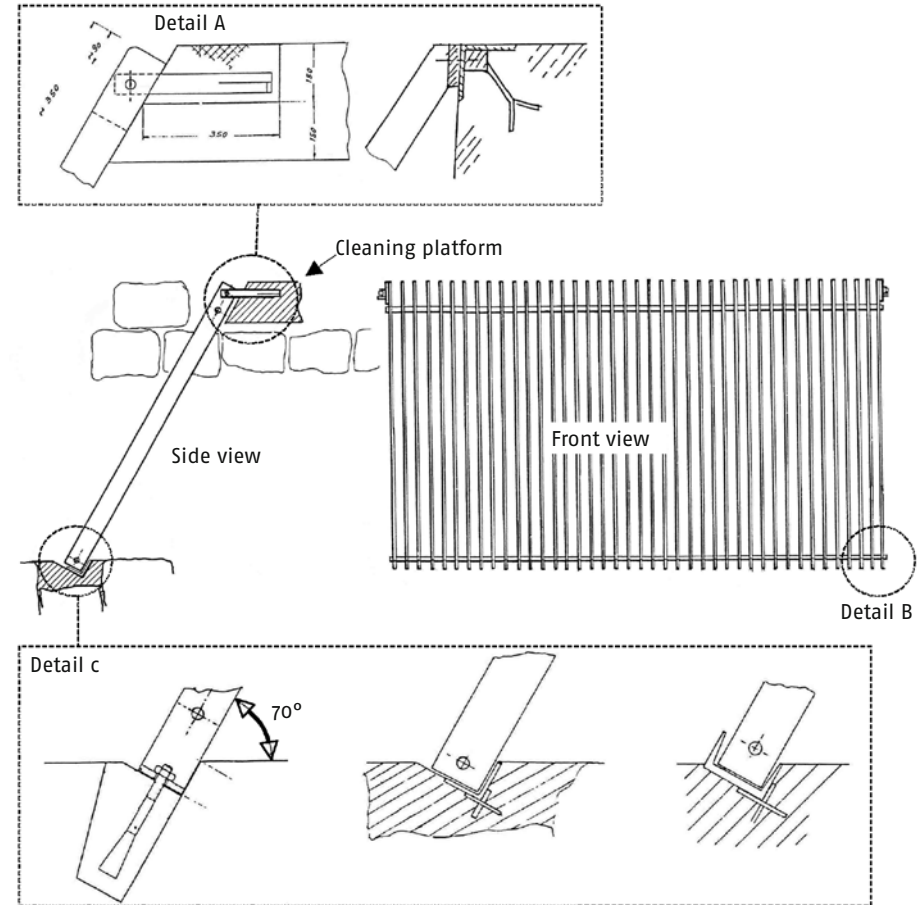
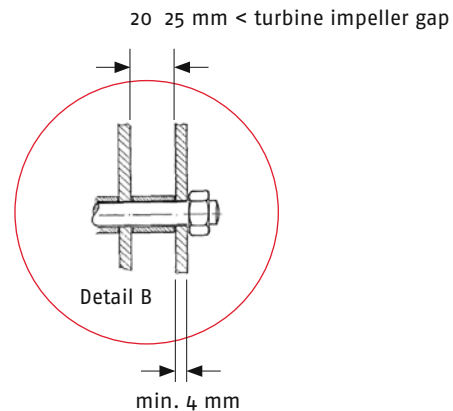

Typical fine trash rack construction

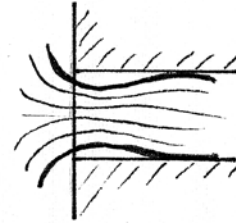
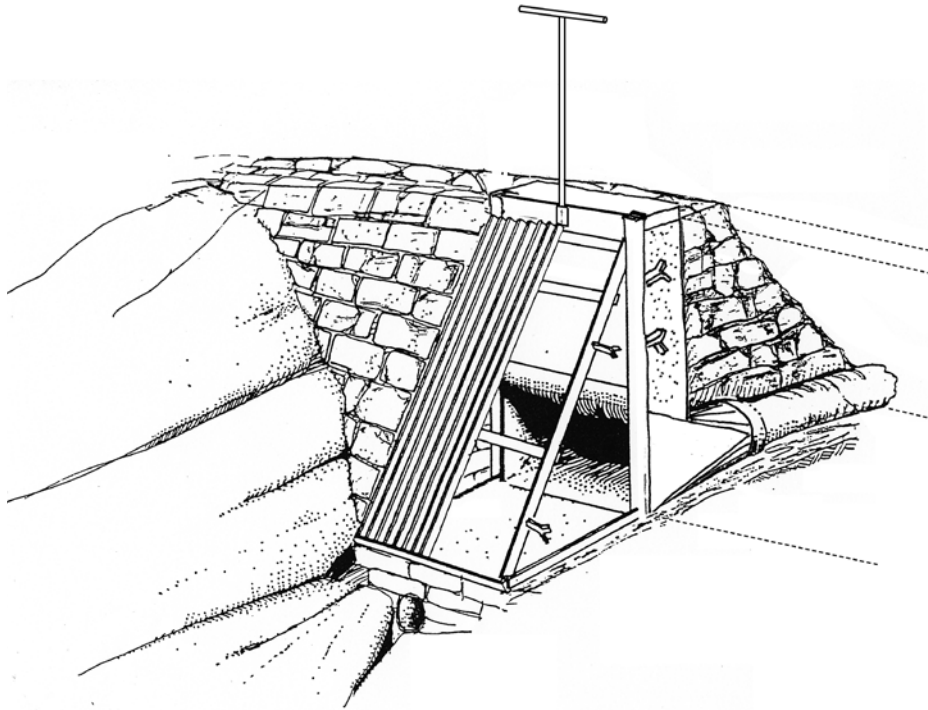

Do not join penstock pipe in original diameter
(flow reduction and air inlet)

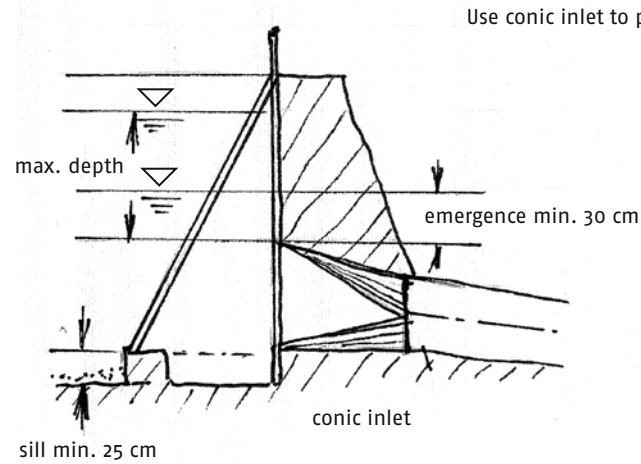

Use conic inlet to penstock

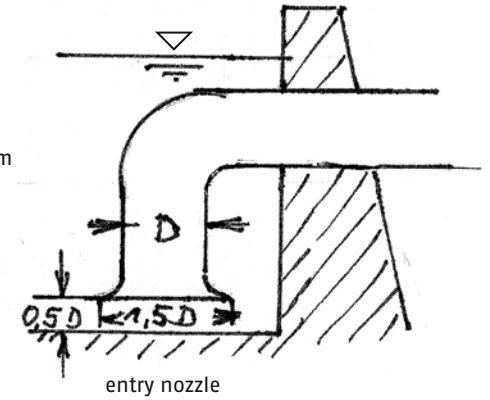

Example (ref. page 33): Intake in rock gorge with premanufactures components ... but adhere to design criteria

6.14 Civil works with natural stones

To save money self-help projects are advised to refer to local resources and use natural stones. Natural stone is locally available and can be collected, broken, shaped and used with mortar for various construction works.

Further advantages include:

- > water proof, suitable for water structures
- > strong – guarantees long lifetime of structures
- > saves bricks and concrete

Applications for water mills:

- > weir and intakes
- > channels and spillways
- > forebay
- > mill building foundations

Other applications:

- > foundations for housing
- > irrigation and drainage
- > flood prevention
- > channel structures
- > water reservoirs

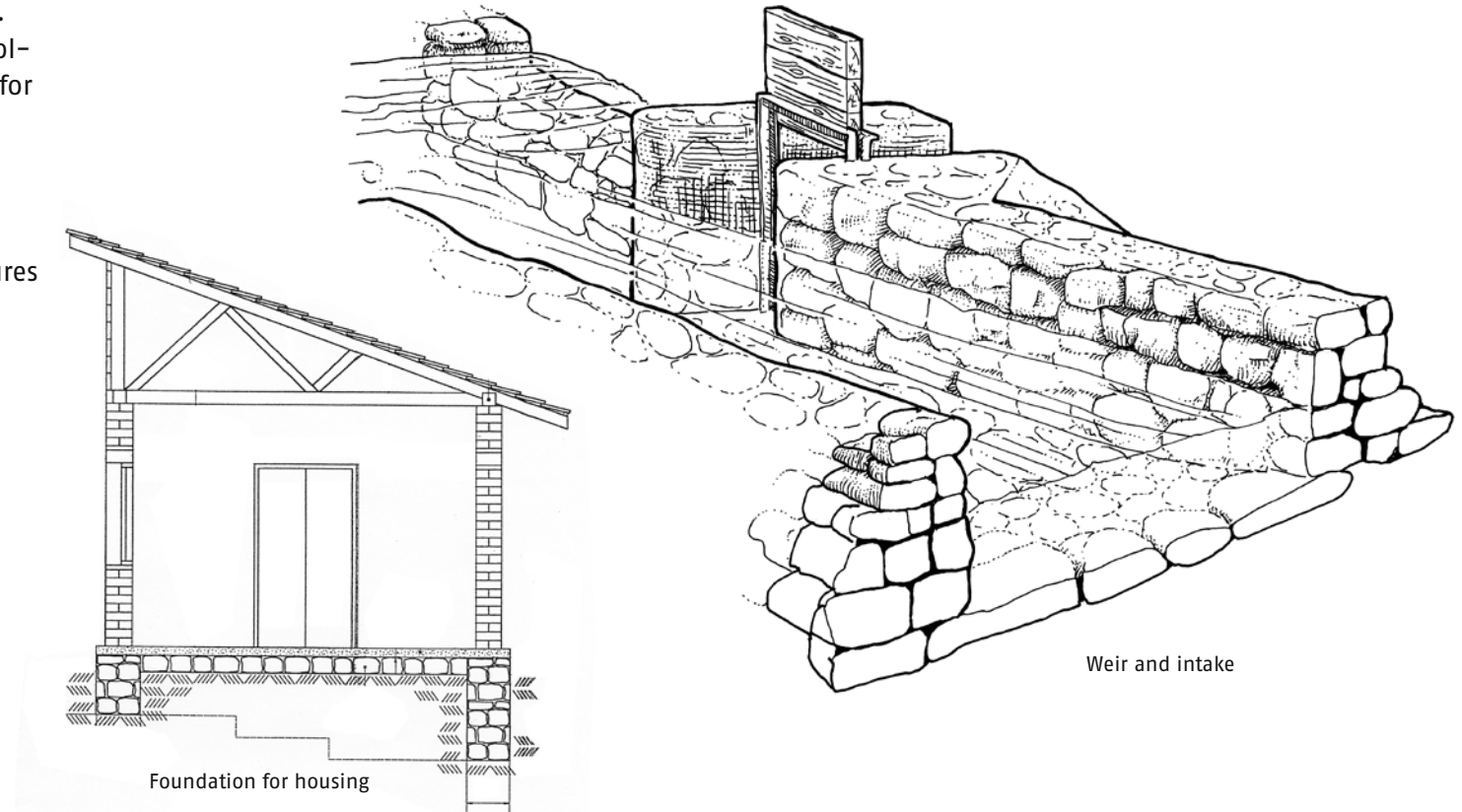

Foundation for housing

Weir and intake

6.15 Where and how to get the stones

1. Collect stones and boulders from fields, slopes, below cliffs etc, i.e. from wherever you can find good shapes and quality.
 - > look out for rectangular shapes or
 - > cut to size
2. Collect and break stones from "outcrops"
 - > remove soil and dig out rocks
 - > look for rectangular shape – and cracks for splitting

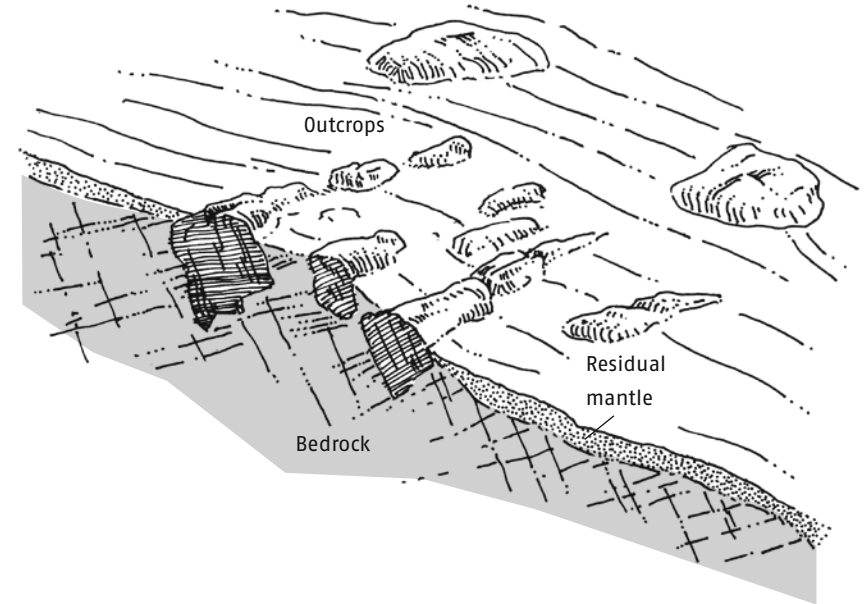
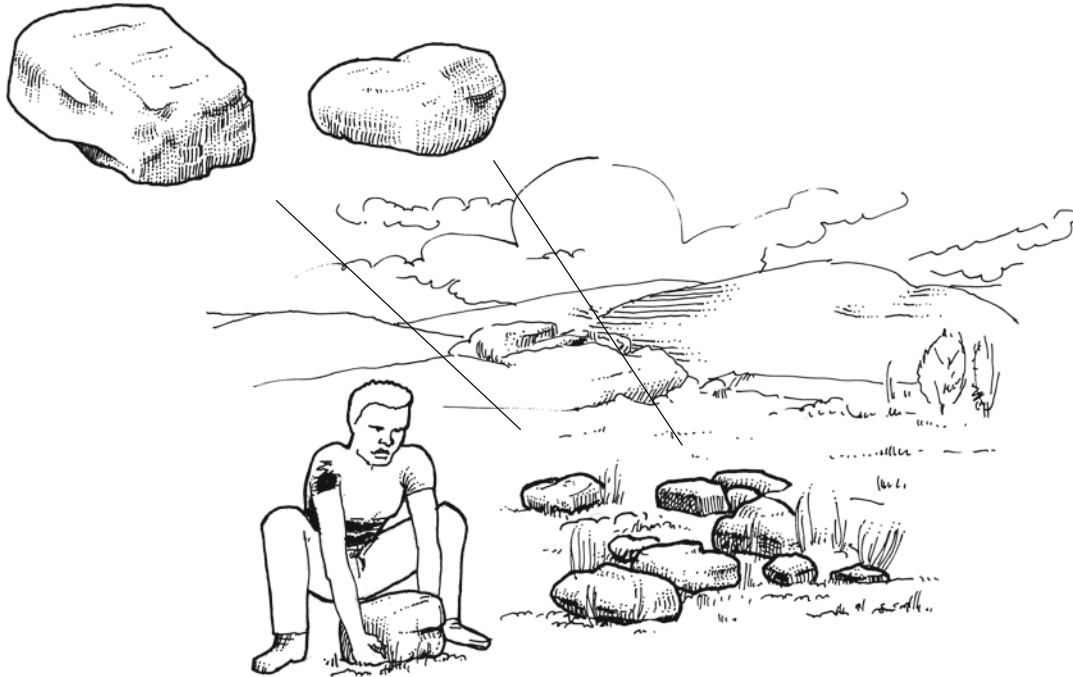

6.16 Stone extraction and preparation



... extraction

... breaking

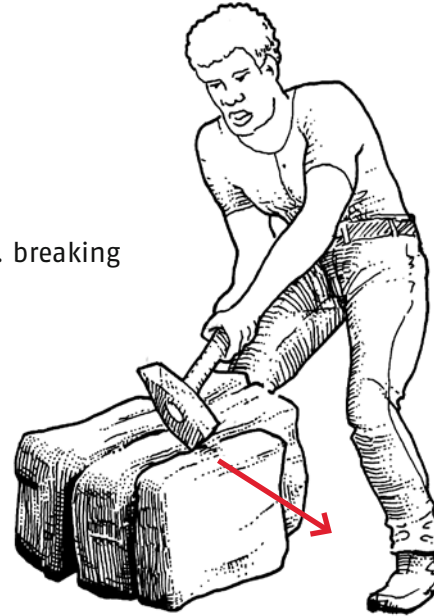

... shaping



6.17 Stone extraction and preparation: tools

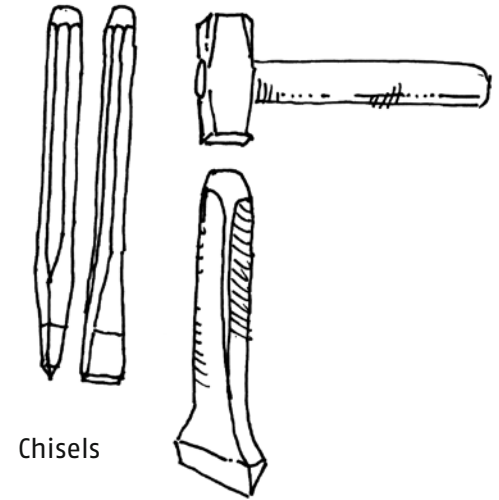
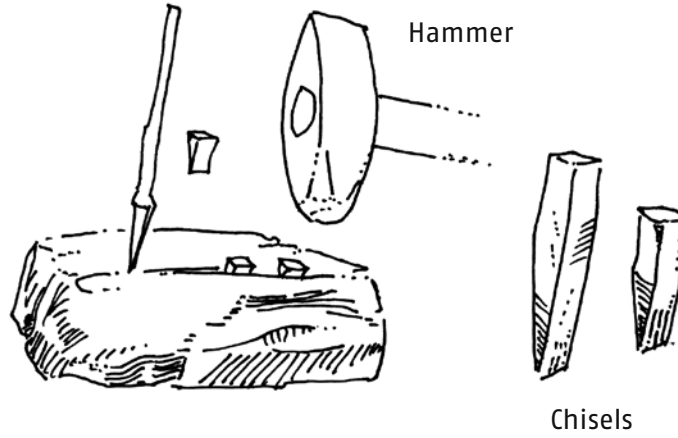
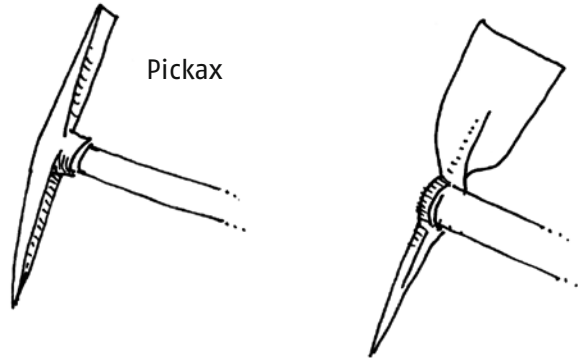
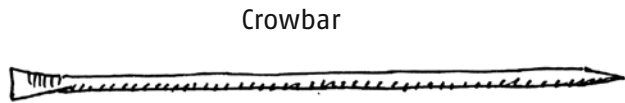

6.18 Breaking the stone: traditional methods

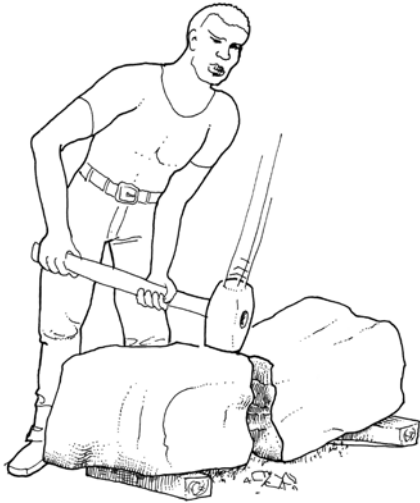

Persistent hammering
with heavy sledge hammer

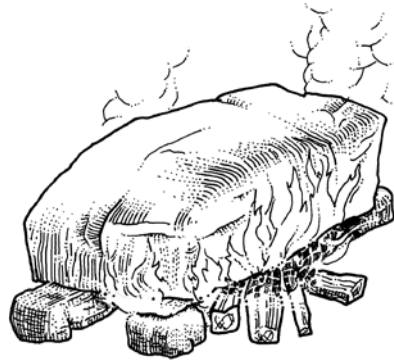

Heating by fire

Pre-cracked rock:
splitting using chis

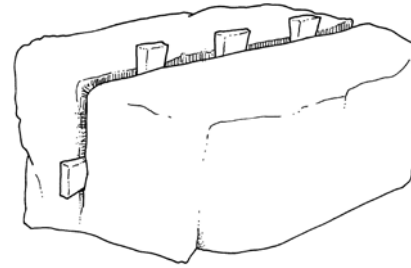

Splitting using wedges



For heavy tasks:
at site, or when developing
a quarry, call for:
drilling and blasing-experts
from town, quarry or road con-
struction, big projects etc.

6.19 Construction with natural stone

When using natural stones for construction you should

- > look at the stone
- > judge its shape and suitability
- > select matching stones for stable construction

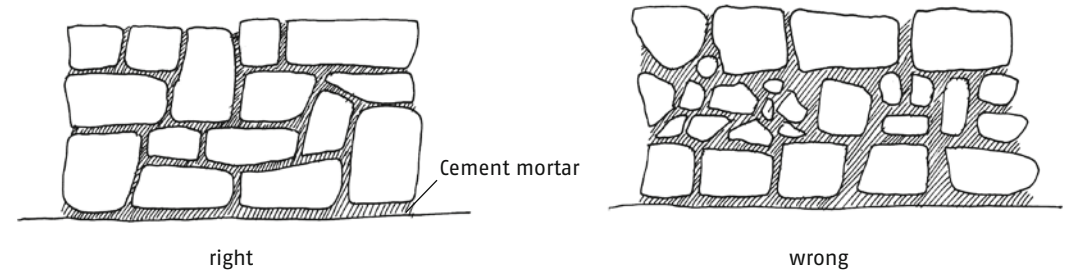
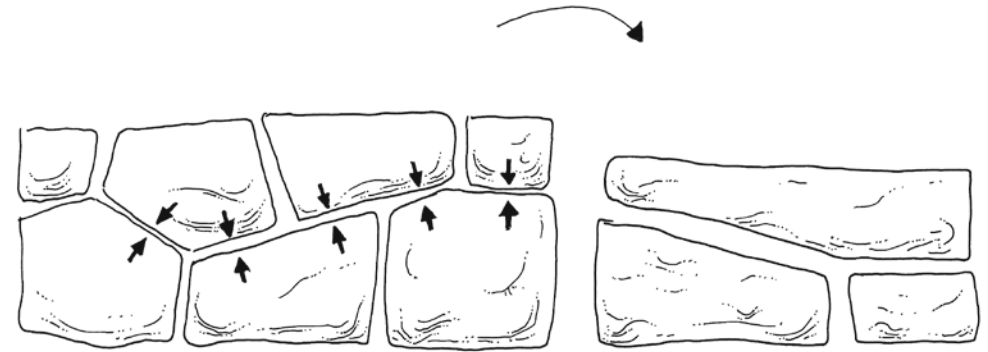
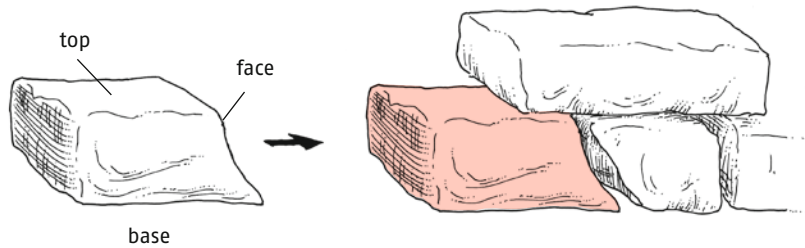

Chip off to match

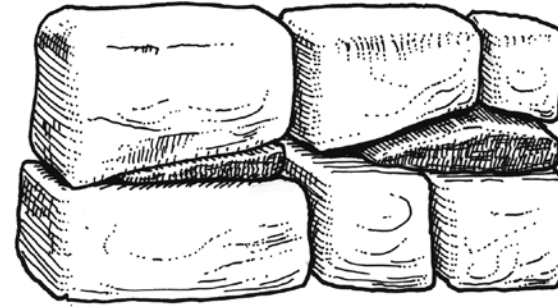
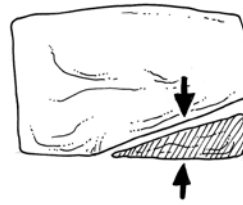
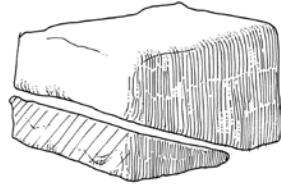
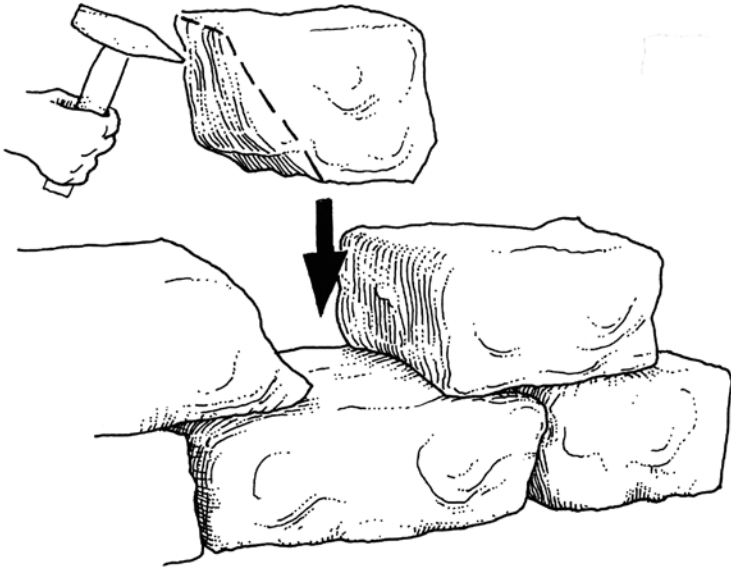

Use shim to stabilize

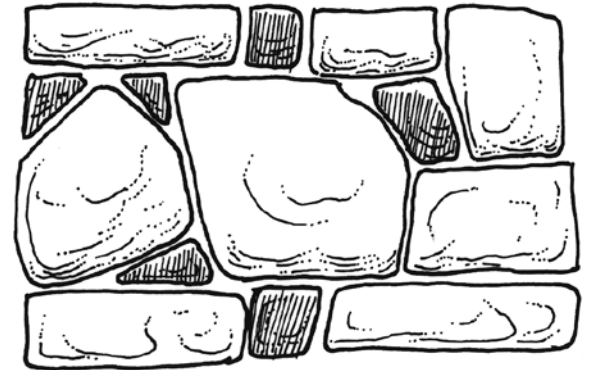

Fill gaps with small stones

6.20 Mortared stone masonry work Preparation for construction / wall

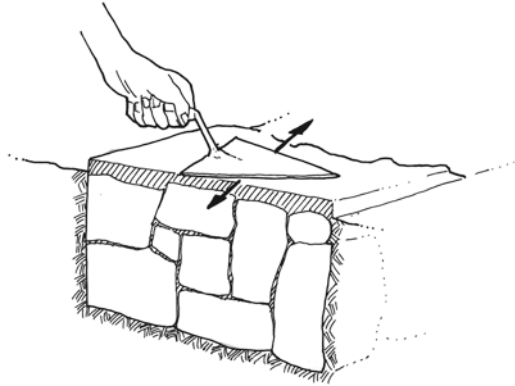

Spread mortar on foundation
to create levelled surface

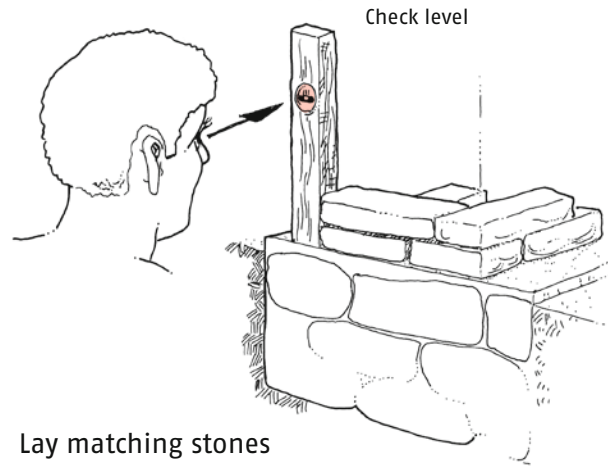

Lay matching stones

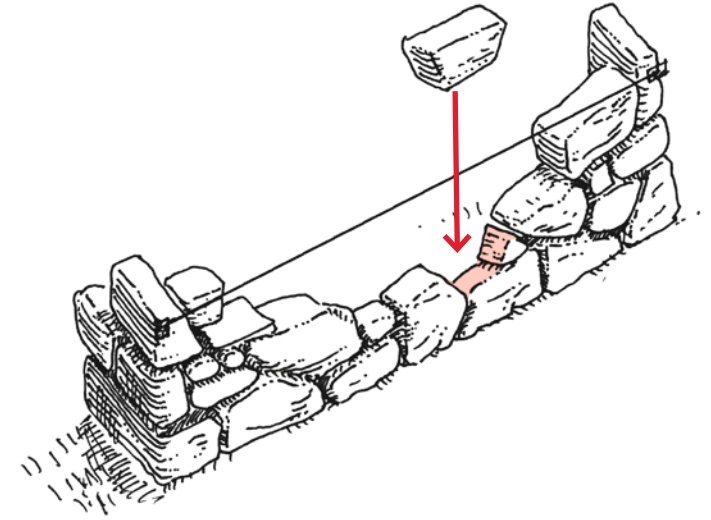

1. Select matching stones
2. Check and fit
3. Apply mortar
4. Check levels

Good

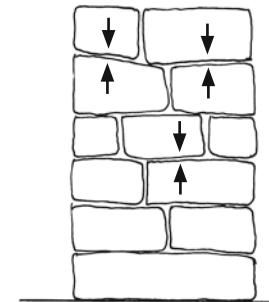

Bad

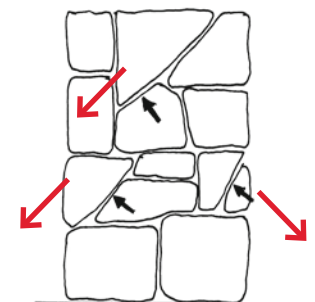

6.21 Footings and Foundations

Try to base your stone structures, weir, walls or mill house on the rock.

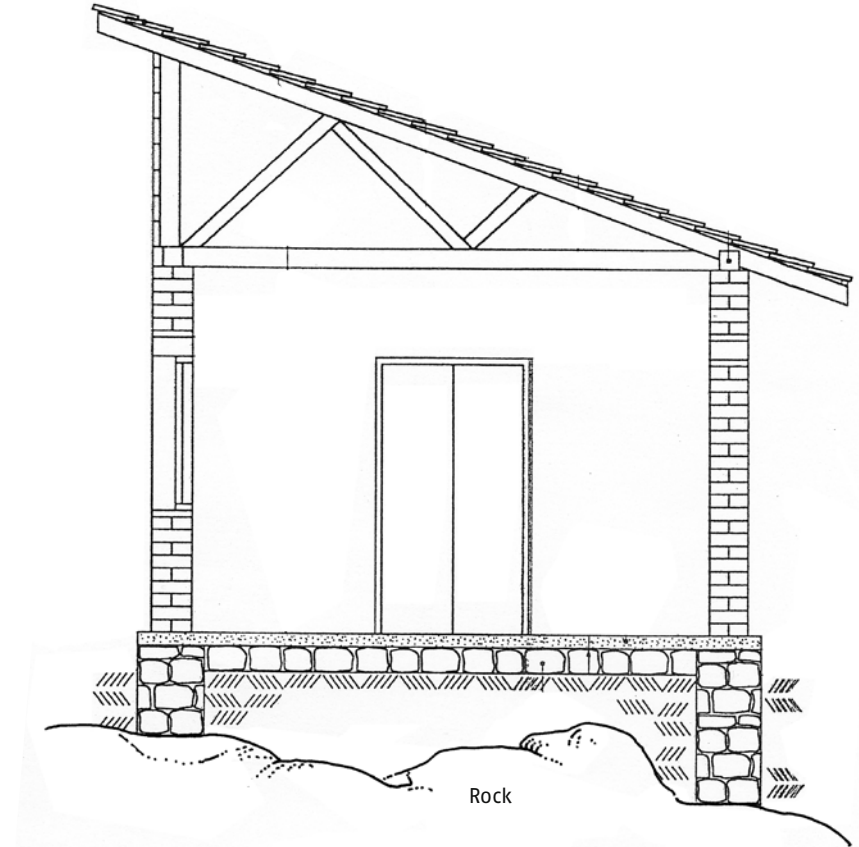
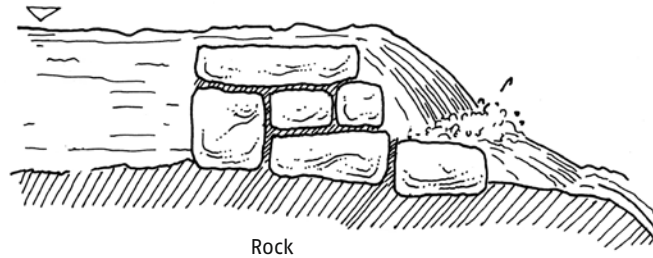

Footing, dug in soil, on compacted earth.

w: width of wall depending on various factors:

- > size of stones
- > height of wall
- > load / forces on wall
- > type of stone
- > facing of stones
- > facing of wall

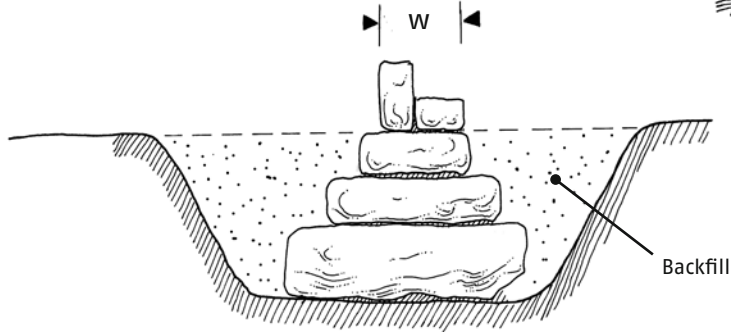
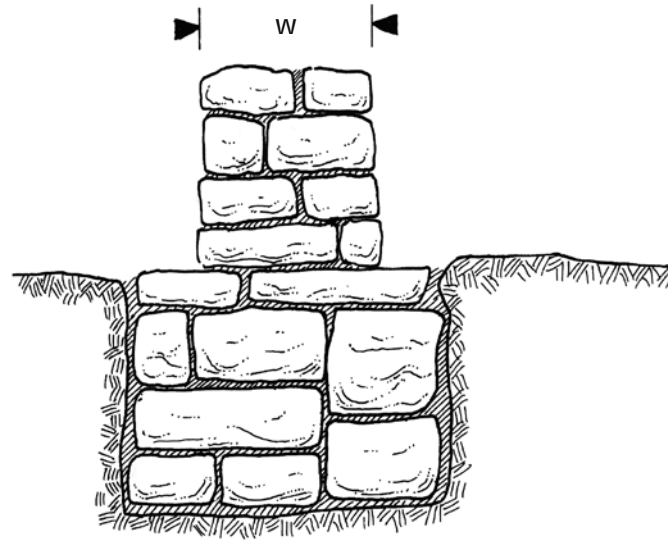

Wall:

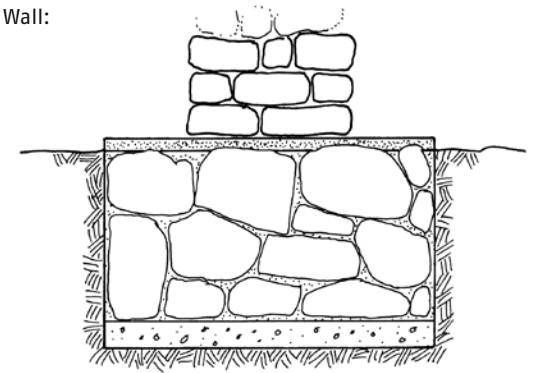

Min. 45 cm

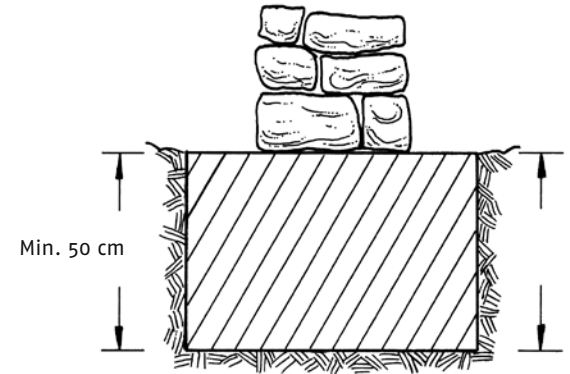

6.22 Masonry works

These are examples for perfect wall constructions using natural stones:

Using natural stones has many advantages:

- > Material is locally available.
- > Labor is locally available (self-help).
- > Money can be saved which otherwise would have to be paid for transport and material (e.g. steel).

Disadvantages:

- > needs 1,5 times more mortar than brick*/block masonry
- > labour intensive
- > difficult transport
- > may cause injuries (eyes etc.) when breaking and shaping stones

* brick work with hard burned bricks and cement /mortar plastering has also been used and sustained over decades

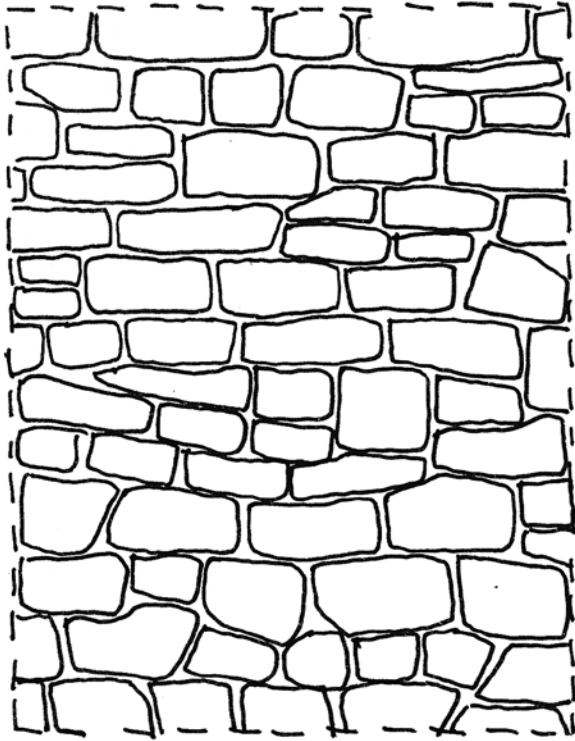

Stone masonry works

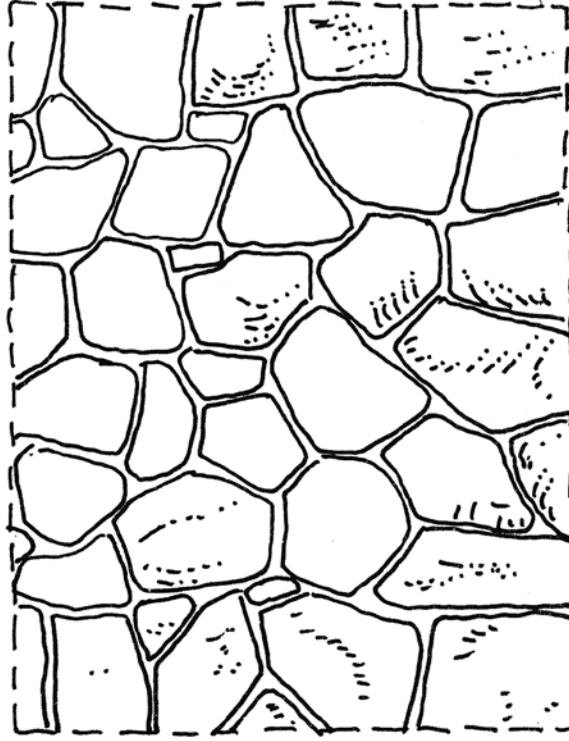

Bolder masonry

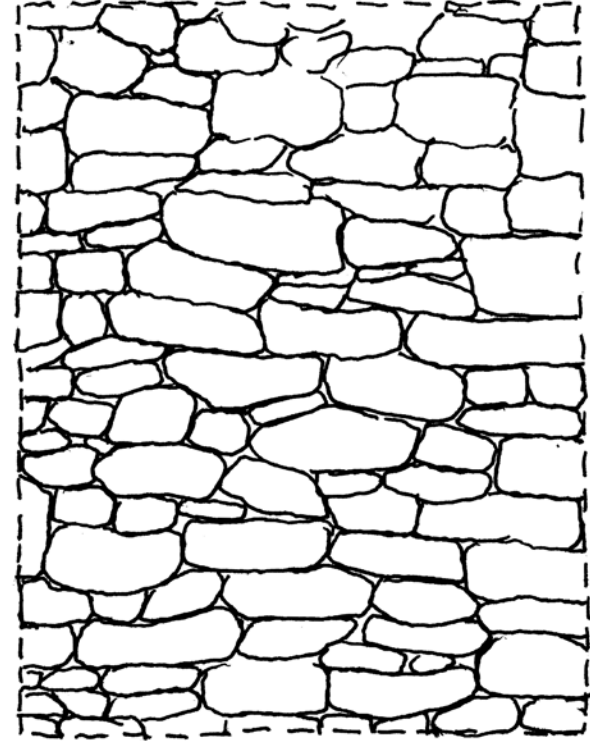

Shaped stone masonry

All mason works in contact with water are to be constructed with concrete mortar

6.23 Brick work / masonry

Cement mortar

shall be composed of
4 parts by volume of sand
1 part by volume of cement

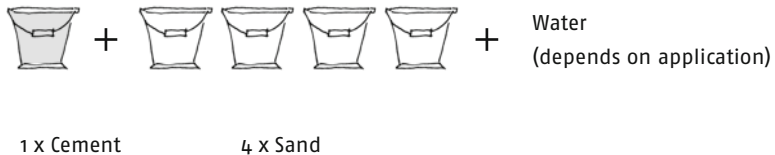

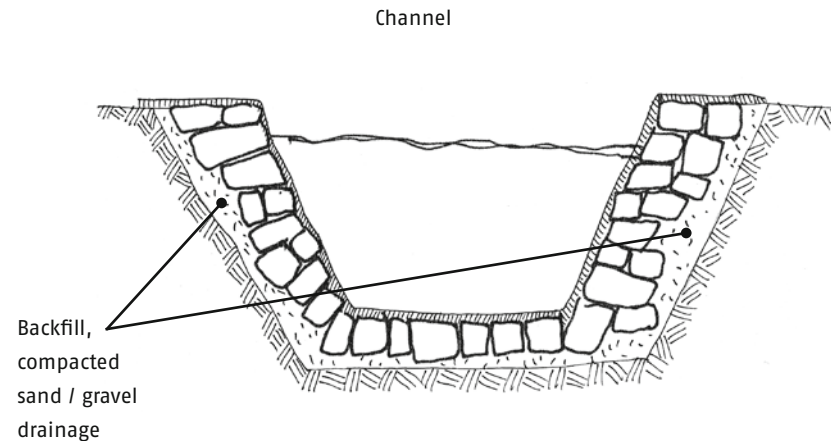

Please note:

Sand shall be evenly graded from fine to coarse, particles measuring max. 4–5 mm. Sand shall be gritty, hard particles free from dust, clay or organic matter. Otherwise to be washed until free of any foreign material.





6.24 Recommended mortar

1. Compo / gauged mortar
Not required to be waterproof

		Cement lime / sand	Grain	Consistency
	Brick	1 : 2 : 9	2 – 4 mm	Plastic
	Blocks	1 : 2 : 9	2 – 4 mm	Plastic / stiff

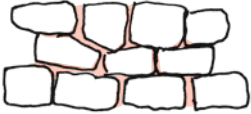
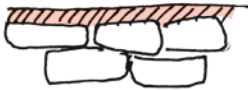
2. Cement mortar
In contact with water. Required to be waterproof.

		Cement / sand	Grain	Consistency
	Natural stones	1 : 4	2 – 4 mm	Plastic / stiff
	Topping	1 : 3	2 – 3 mm	Stiff
	Pointing	1 : 2	2 – 3 mm	Plastic

6.25 Recommended plaster

1. Waterproof plaster

This plaster is required for construction components where the stone quality is not adequate to withstand the forces of flowing water (channel, forebay etc.).

It is applied in two courses (layers) with a total thickness of ~ 25 mm. On smooth surface it is recommended to knock off small particles of the stone / concrete with a hammer to create a rough surface. Alternatively a cement slurry (splatterdash) can be applied to create a rough surface.

The standard mixture:
Cement to sand is 1 : 4

2. Common plaster

This plaster is widely used in the construction industry with brick and stone masonry where the plaster may not be required to be waterproof (powerhouse-superstructure).

The standard mixture:

1 part cement, 2 parts lime, 9 parts sand

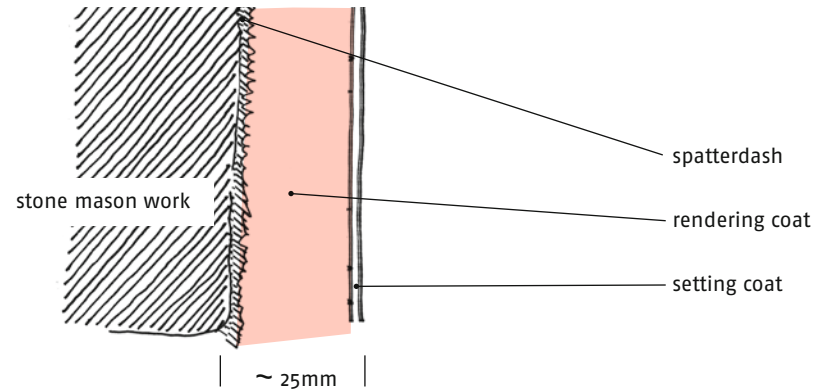

6.26 Concrete

1. Lean concrete (PC 150)

shall be composed of
6 parts by volume of gravel
4 parts by volume of sand
1 part by volume of cement

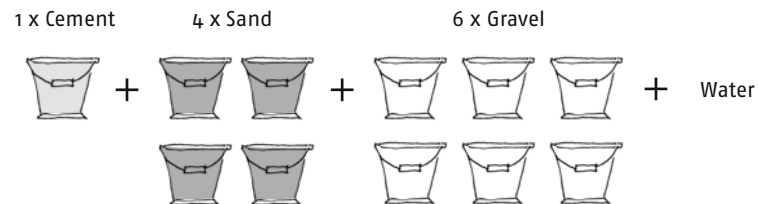
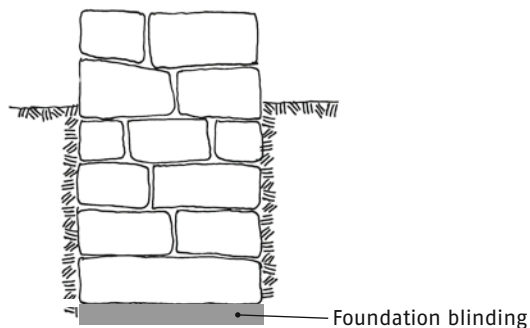

2. Unreinforced concrete (PC 200)

shall be composed of
5 parts by volume of gravel
3 parts by volume of sand
1 part by volume of cement

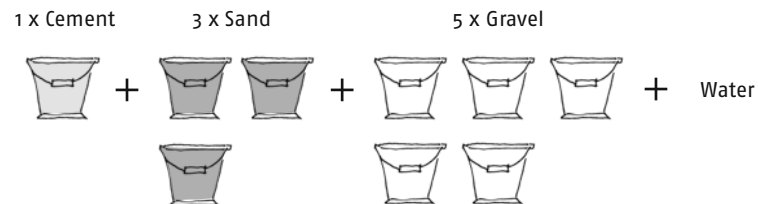
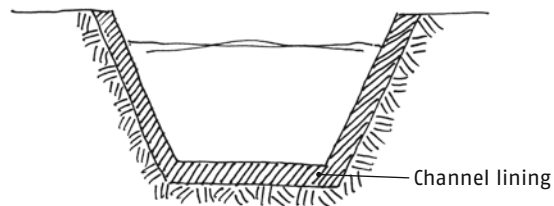

Reinforced concrete (PC 300)

shall be composed of
3 parts by volume of gravel
2 parts by volume of sand
1 part by volume of cement

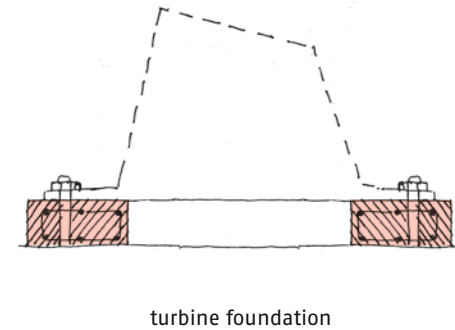
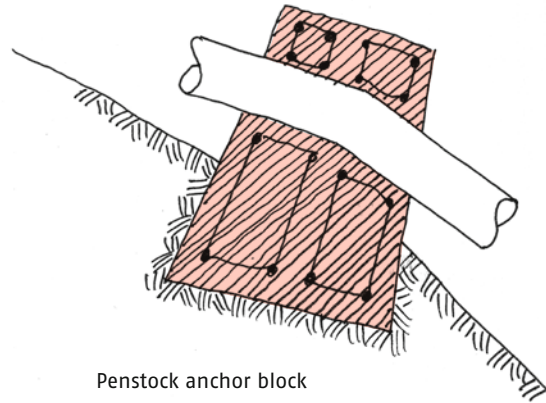
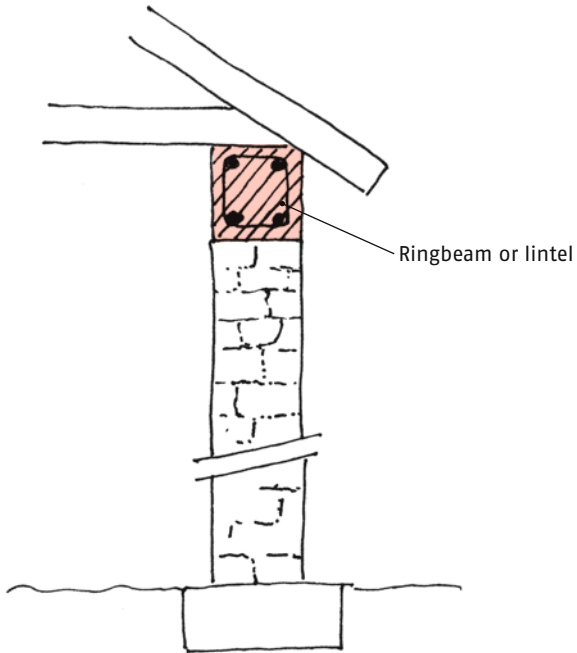
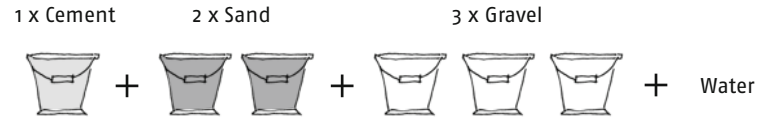

7. CONVERSION OF WATER ENERGY

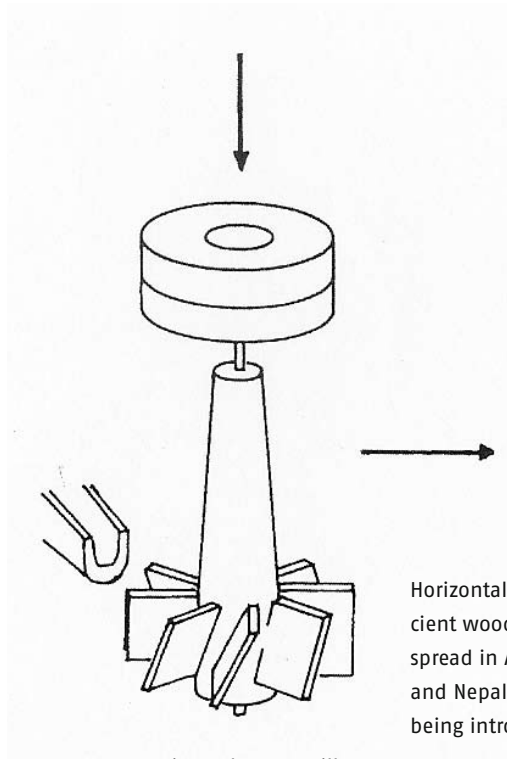

Horizontal water mill
(Greek water mill)

Conversion of water power,
known for 2000 years

Horizontal wheels with crude, low efficient wooden paddles are still widespread in Afghanistan, Pakistan, India and Nepal. Improved steel runners are being introduced.

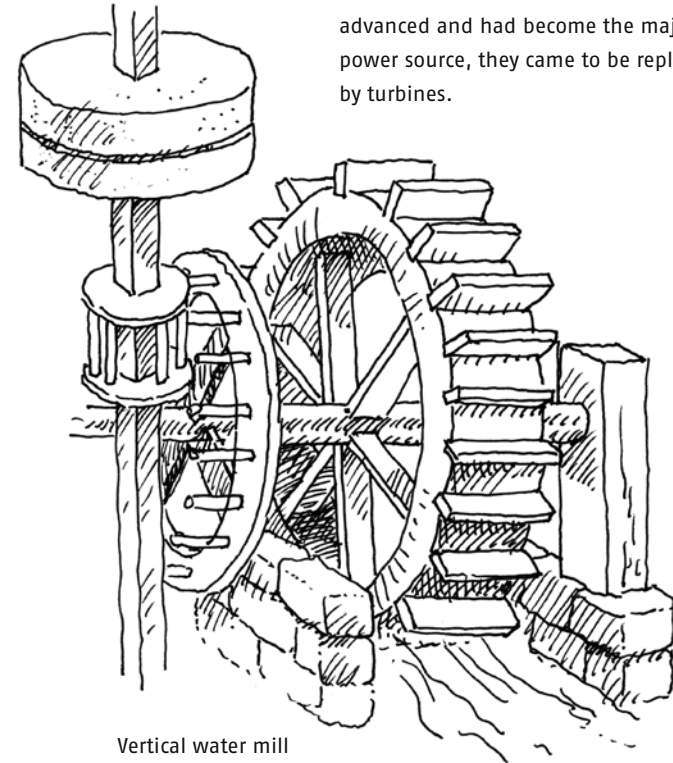

Vertical water mill
according to Vitruvius (Roman)

Although in the course of the industrialisation vertical water wheels were highly advanced and had become the major power source, they came to be replaced by turbines.

7.1 Development of horizontal water wheel plants

Improved wheels in steel are being spread in Ethiopia, Pakistan (existing or spreading on private initiatives), Nepal and India in successful programmes.

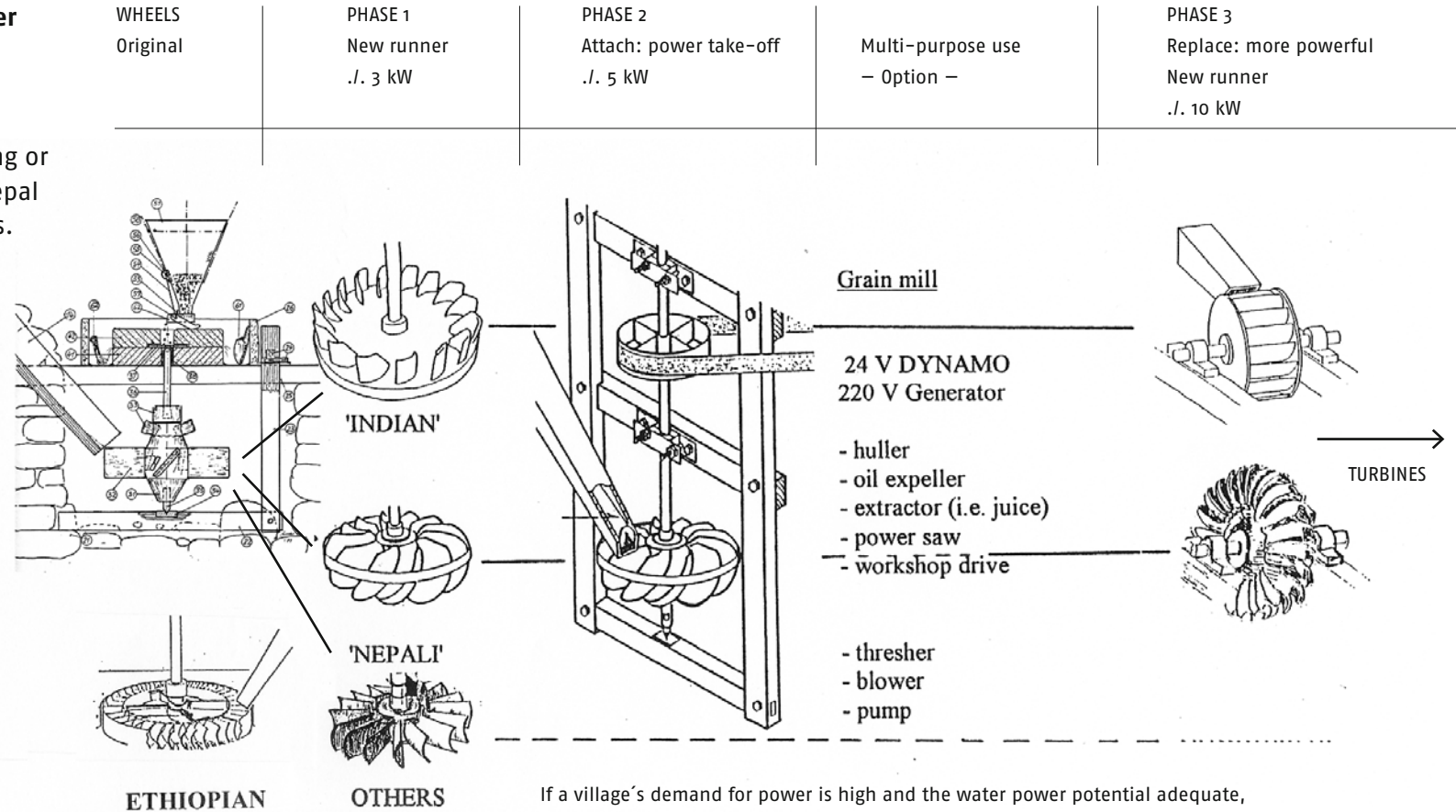

If a village's demand for power is high and the water power potential adequate, it is recommended to introduce water turbines, replacing the old watermills.

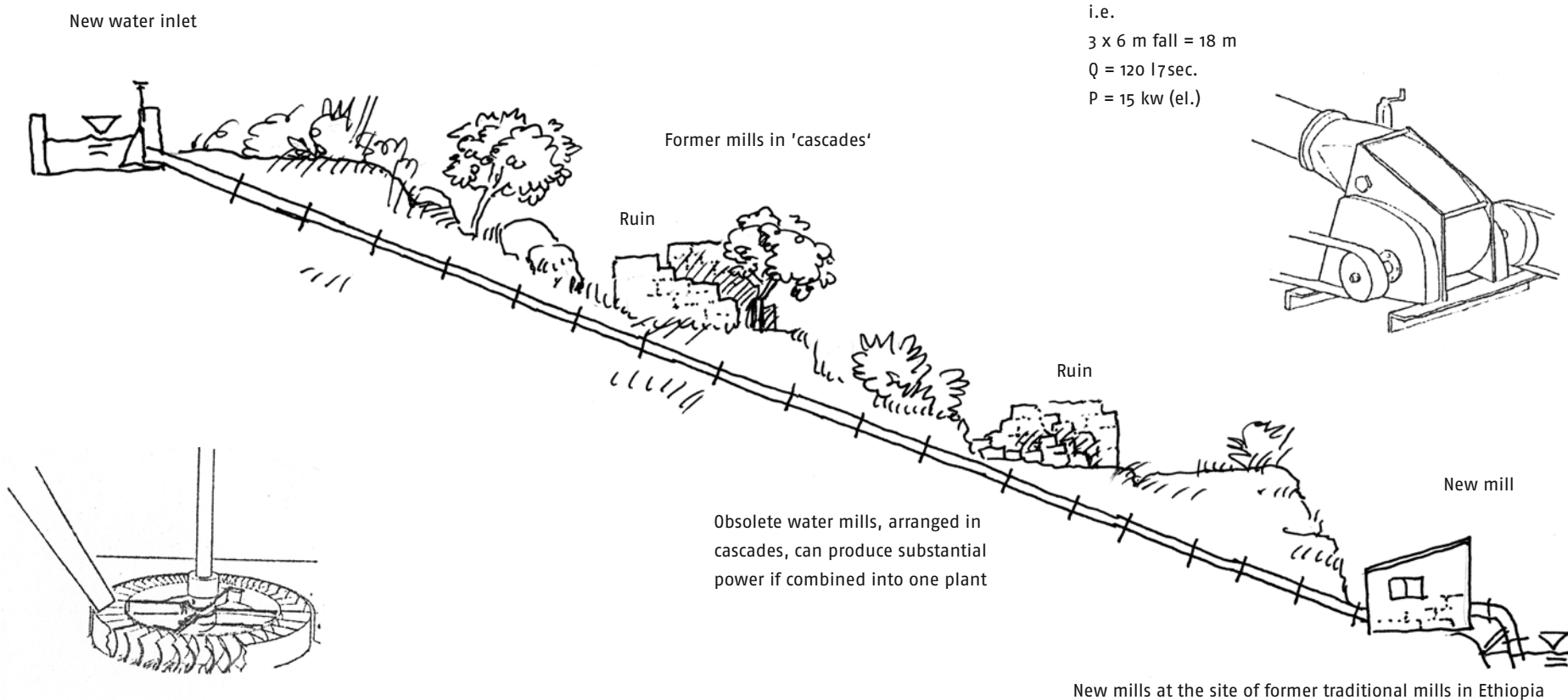

7.2 Overview vertical water wheel

Characteristics according to head / fall

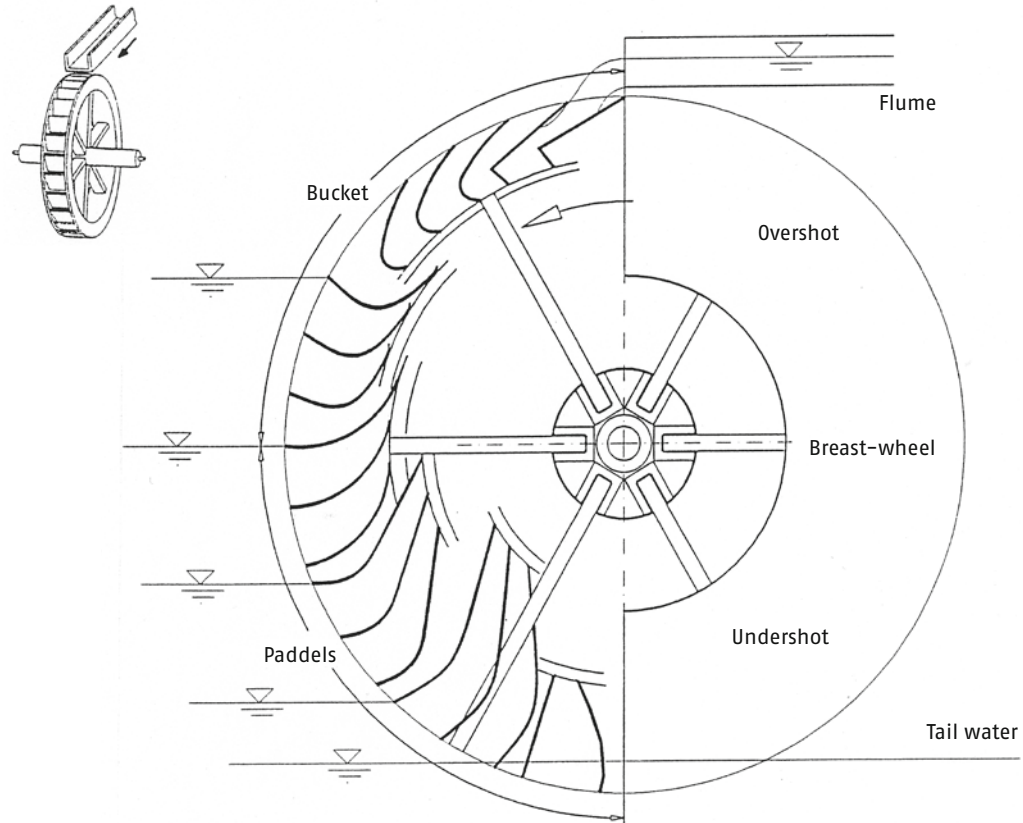

Wheels

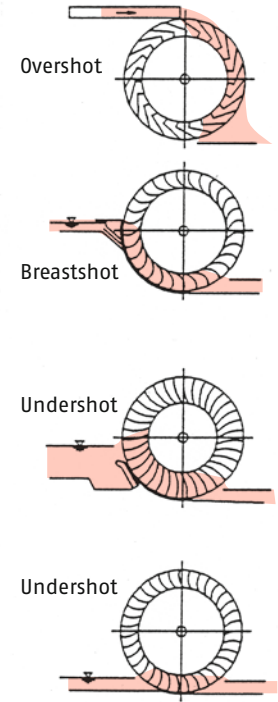

7.3 Water wheel techniques

Hydraulically optimized blades for each type of wheel 4.1 (see Fig. 6)	Appropriate regulation of flow 4.2 (see Fig. 7)	Old and new solutions for the first stage of power transmission 4.3	Traditional and modern power transmission 4.4
<p>Wheels:</p> <p>Overshot</p> <p>Breastshot</p> <p>Breastshot</p> <p>Undershot</p>	<p>Flume</p> <p>Quick acting valve</p> <p>Paddle valve</p> <p>Poncellegate</p> <p>Regulation by water level</p> <p>Overflow</p>	<p>I. Power Transmissions</p> <p>Gears</p> <p>Gear Spur gear</p> <p>Friction gear</p> <p>Cog wheel</p> <p>II. Options</p> <p>Chains, Belts</p> <p>Silent chain</p> <p>Linked belt</p> <p>Convent. belts</p> <p>roller chain</p>	<p>auxiliary motor converted into generator</p> <p>Spur gear in first stage or in second stage</p> <p>Hydrostatic drive</p> <p>Planetary gear</p>
<p>Manual operation</p> <p>converted to motor drive</p> <p>"Griesholm" (Handwheel, Lever, chain)</p> <p>with gear motor and arresting magnet</p>			

The technique of water wheel plants

7.4 Development of water wheels into modern turbines

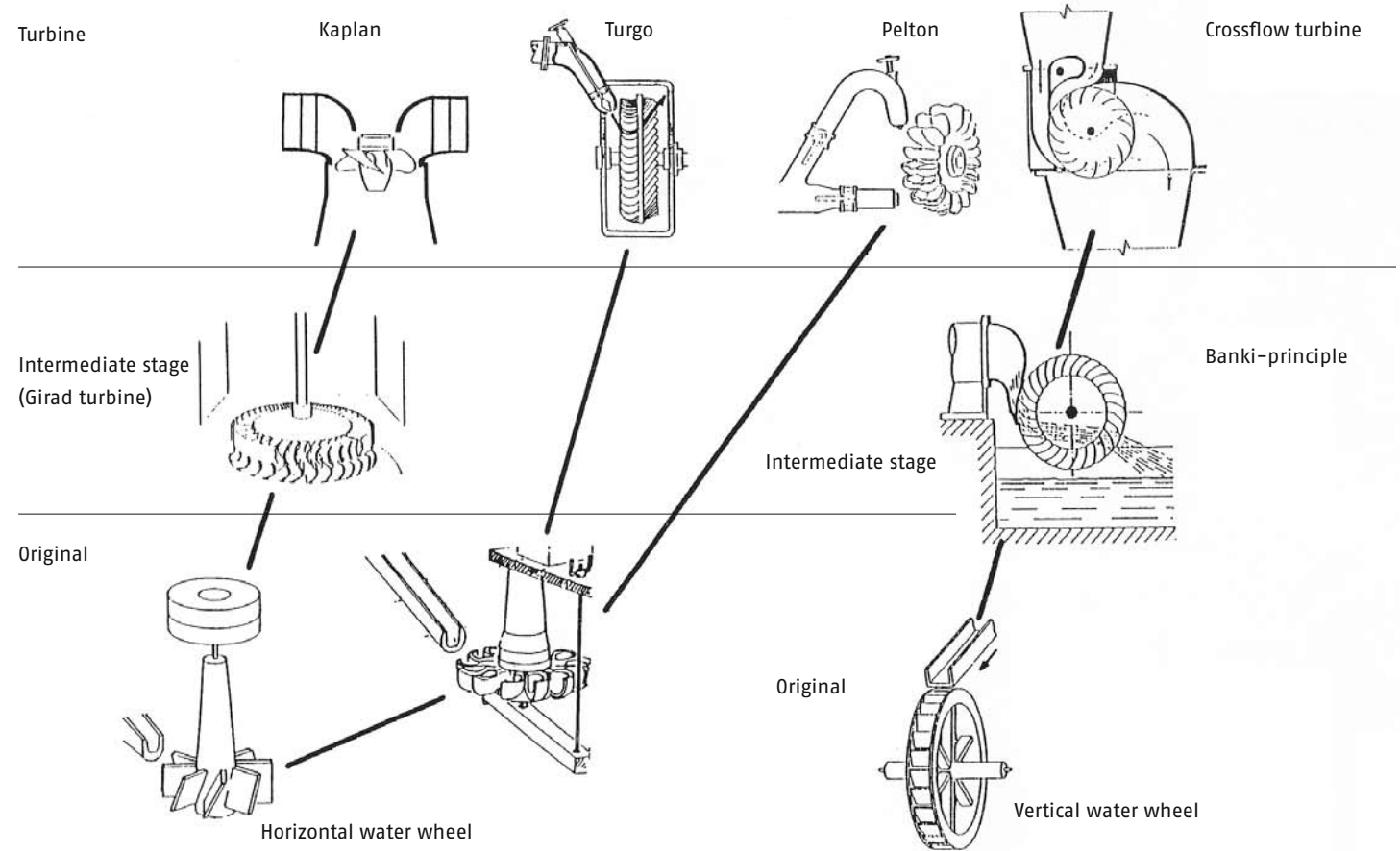

8. TURBINE OVERVIEW

The potential energy of water is converted into mechanical power in a rotating machine, the turbine. The design of turbines depends on the head and flow and is classified into two main types:

Impulse turbines are driven by the water velocity of a water jet directed towards the runner. The runner operates above the tail water level. Impulse turbines, such as Pelton and Turgo, are used in high and medium head plants, whereas the crossflow turbine covers the ranges of low and medium heads.

The **reaction** turbines convert the energy in the runner fully immersed in water within a casing. Guide vanes and runner profiles are shaped for optimal energy conversion in the flow. The runners are located above the tail water level, converting also the energy in a conic draft tube or diffuser.

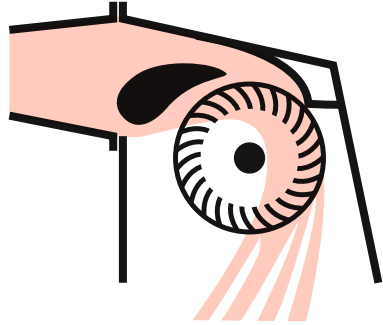
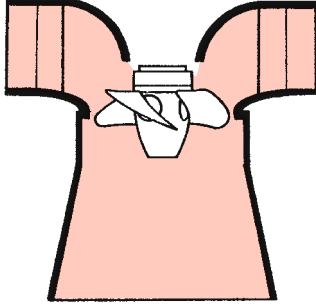
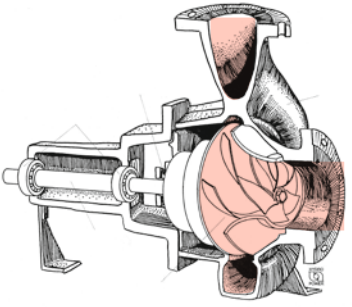
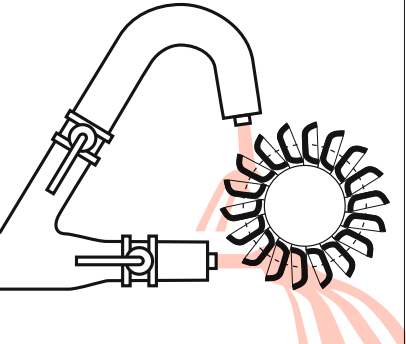
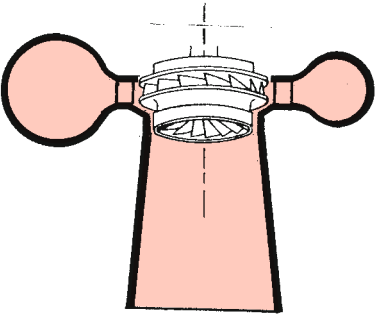
Type of Turbine	Impuls	Reaction		
Head / Fall	Medium / Low	<p>Crossflow turbine</p> 	<p>Propeller / Kaplan turbine</p> 	<p>Pumps as turbines (PAT): covering the full range: propeller to standard pumps single stage to multi-stage pump</p>  <p>PAT</p>
	High	<p>Pelton turbine</p> 	<p>Francis turbine</p> 	

8.1 Crossflow

Crossflow turbines are also referred to as Banki, Mitchell or Ossberger turbines. The water passes through the drum-like radial runner, hitting the curved runnerblades twice. A flow-regulating guide vane enables the turbine to cope with the wide flow range at a fairly good efficiency level.

Due to its good operating range, this model is widely used all over the world and was the first to be manufactured in developing countries. In some regions it has become the standard model.

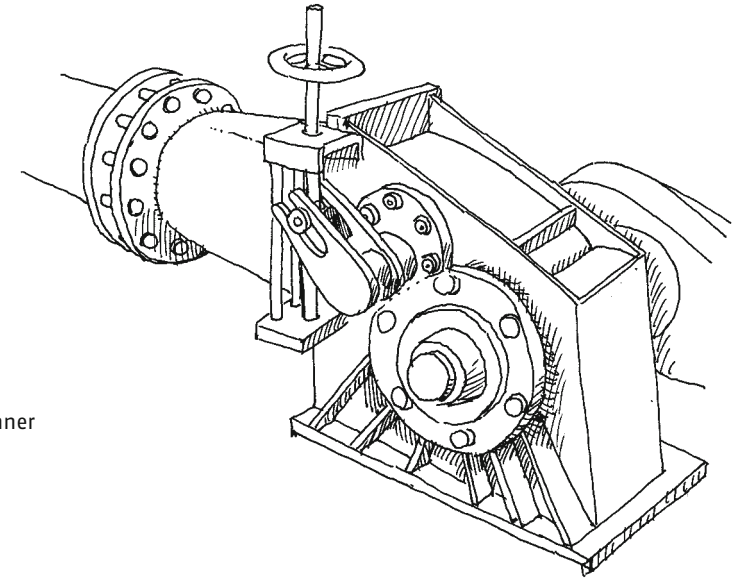
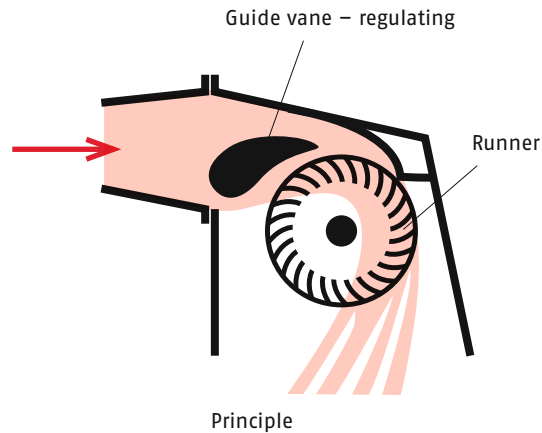

T15 turbine (ENTEC)

Ossberger crossflow turbine

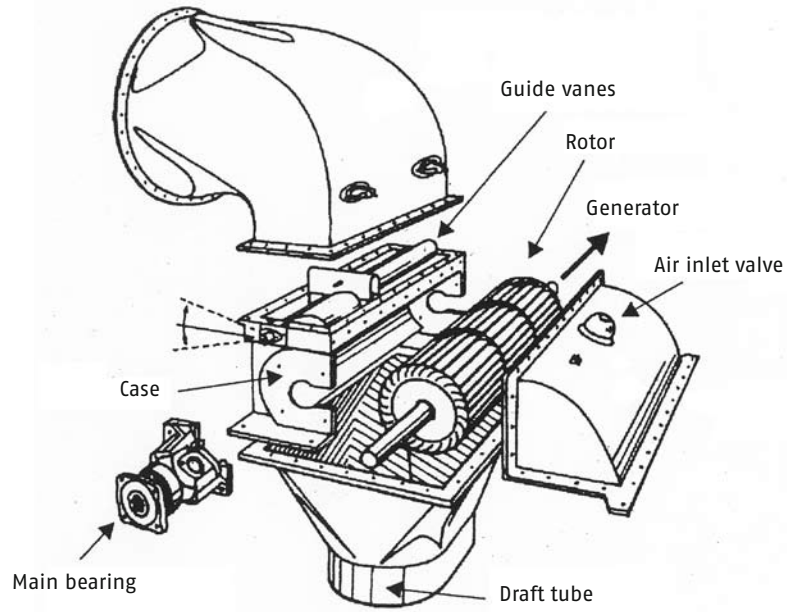

T15 (ENTEC) crossflow turbine

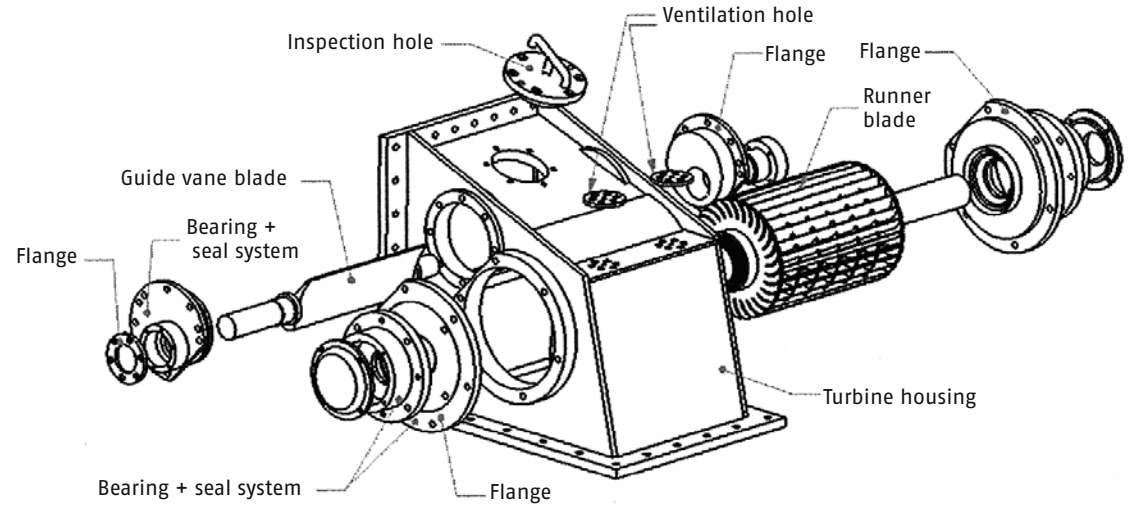

Application range of the T15-300

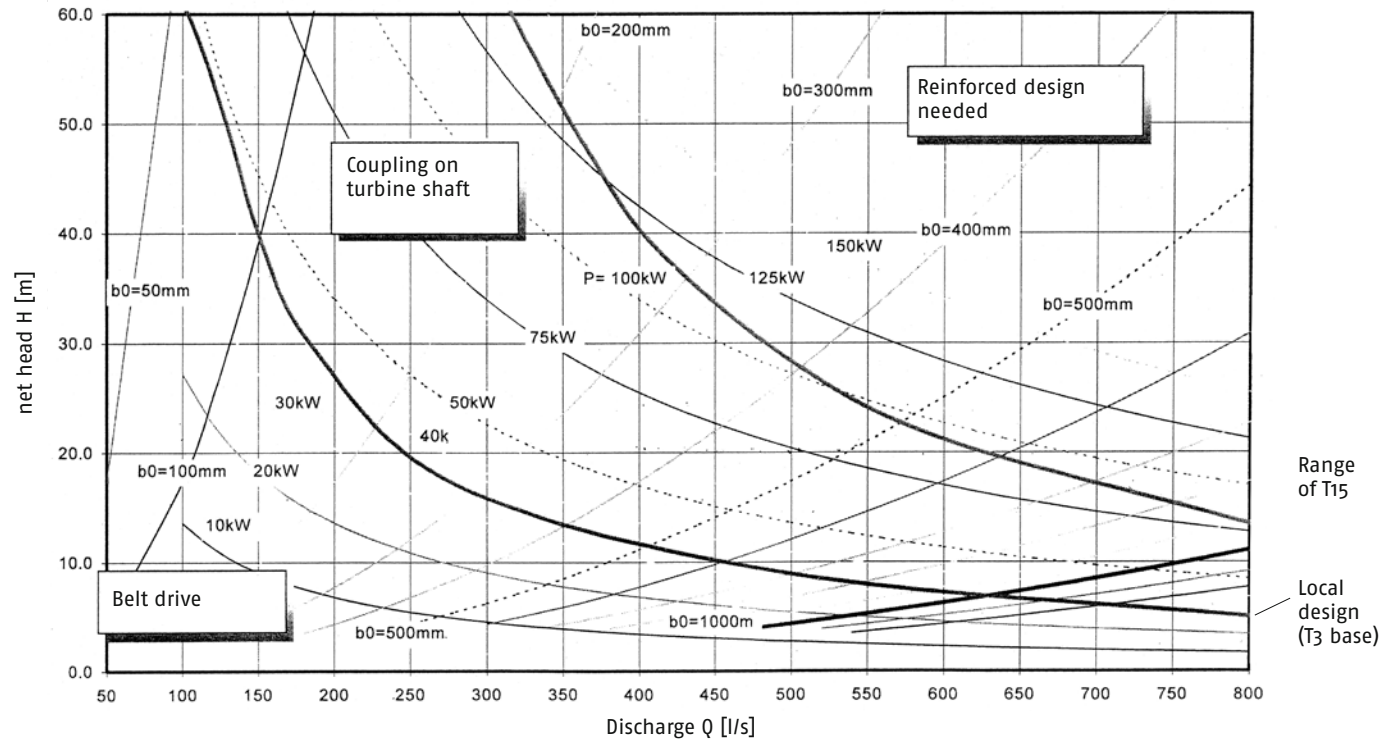

Crossflow simple design

The basic design for locally manufactured cross-flow turbines was developed around 1980 in Butwal / Nepal, known as type 205 and by BYS in Kathmandu as T3 and modified versions (T5, T7. ...). They are now used in many countries. A construction design integrating the latest developments, is under way (by ENTEC, Bandung).

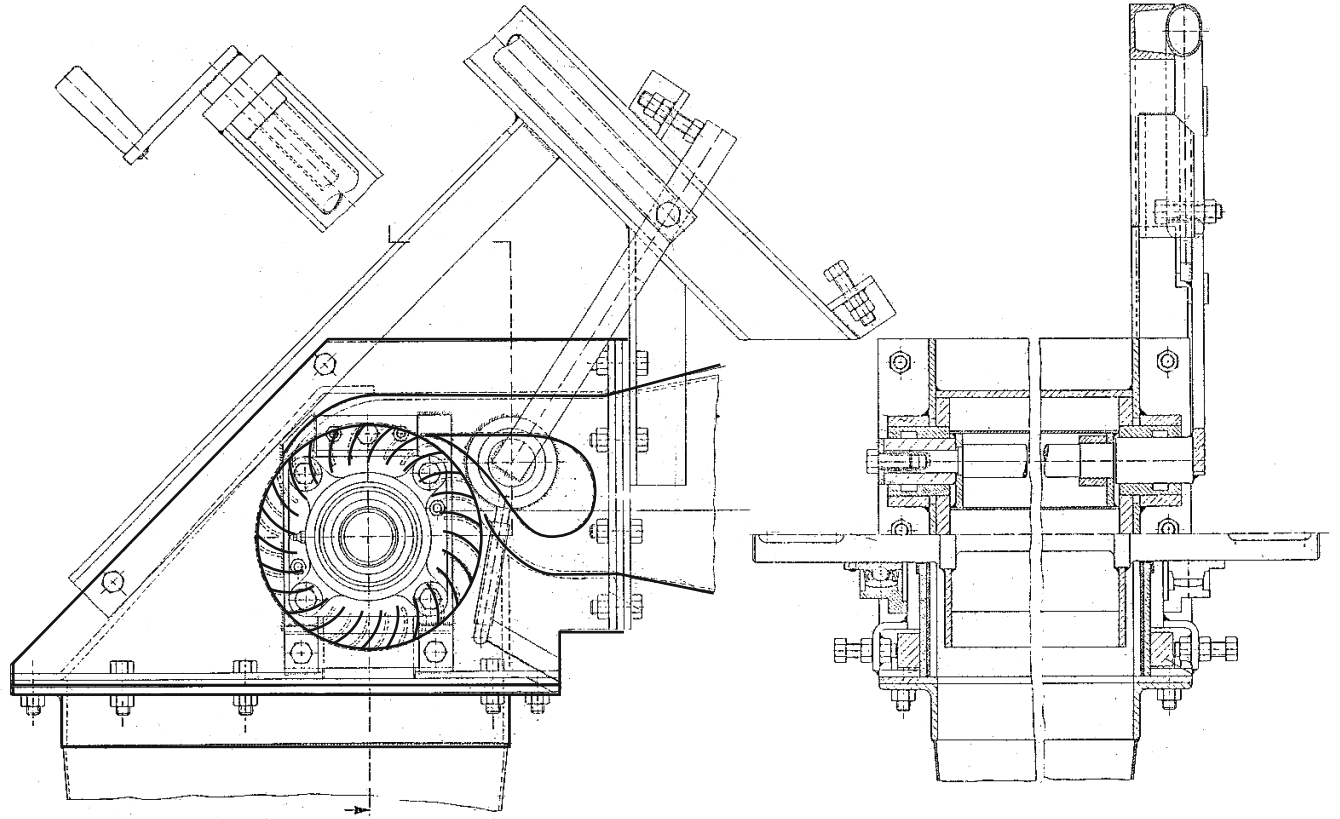

Assembly drawing of crossflow turbine type 205

8.2 Impulse turbines: Pelton turbine for medium and high head

In the Pelton turbine, the pressurized water is converted into a high-speed jet by passing it through a nozzle. The jet hits the specially shaped buckets of the turbine rotor, causing it to rotate.

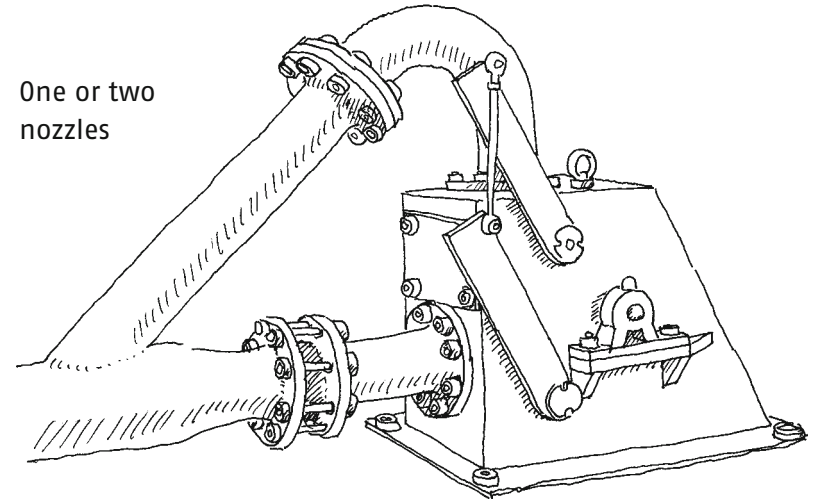
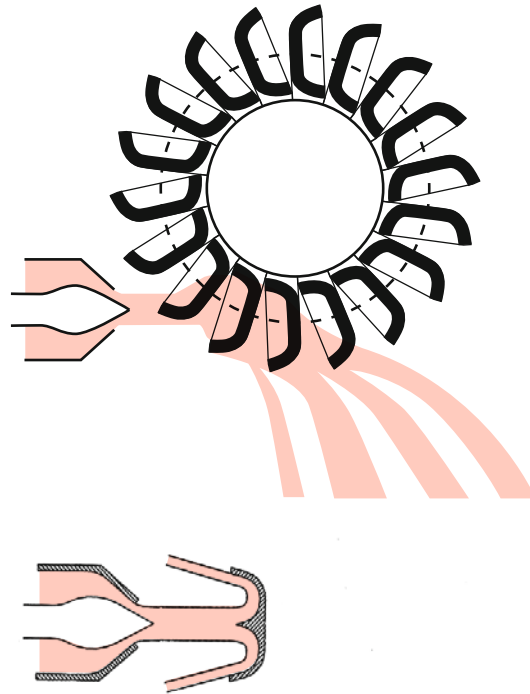

(Multi-nozzle for big plants)

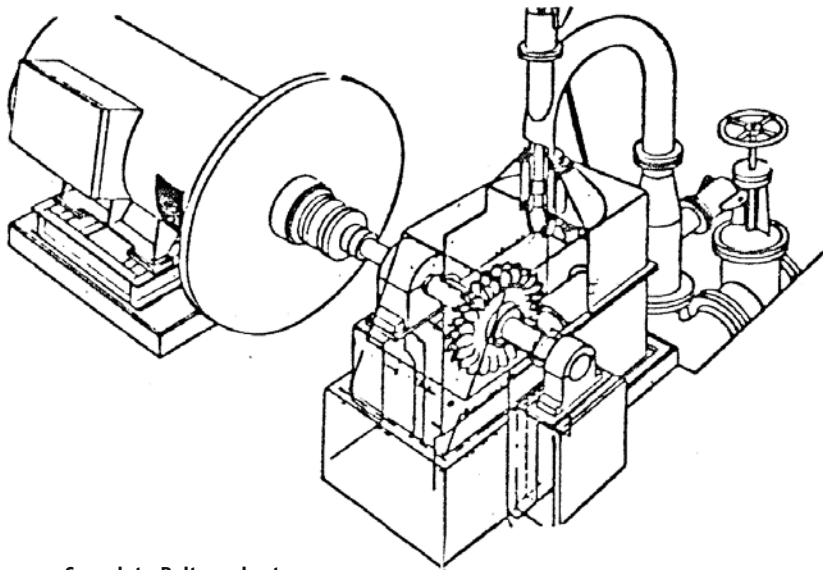

Complete Pelton plant

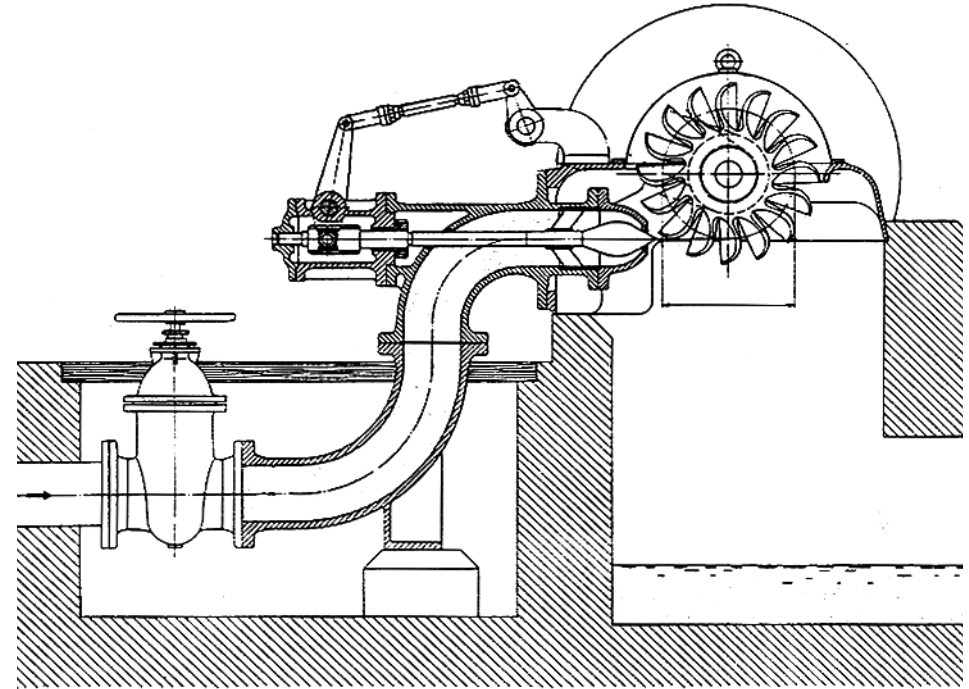

Cross-section of Pelton turbine

Source: Voith

8.3 PAT / Pump as turbine

Pumps are highly developed rotational fluid machines, which are standard machines in different varieties. If operated in reverse they operate as turbines – known as Francis turbine principle.

Advantages of PAT application:

- > cheaper compared to conventional turbines
- > design features: simple, sturdy and approved components
- > spare parts are easily available; refer to pump service and availability
- > easy operation and maintenance
- > manufacturer service and representation available

Summary: Acceptability of technology poses no problems as pump knowledge is wide spread and familiar.

Disadvantages:

- > pumps can only be controlled over a small range by valves, unless multiple units are used
- > design has to be adjusted to "firm flow" (=minimum flow of the year), unless day storage is provided for balance

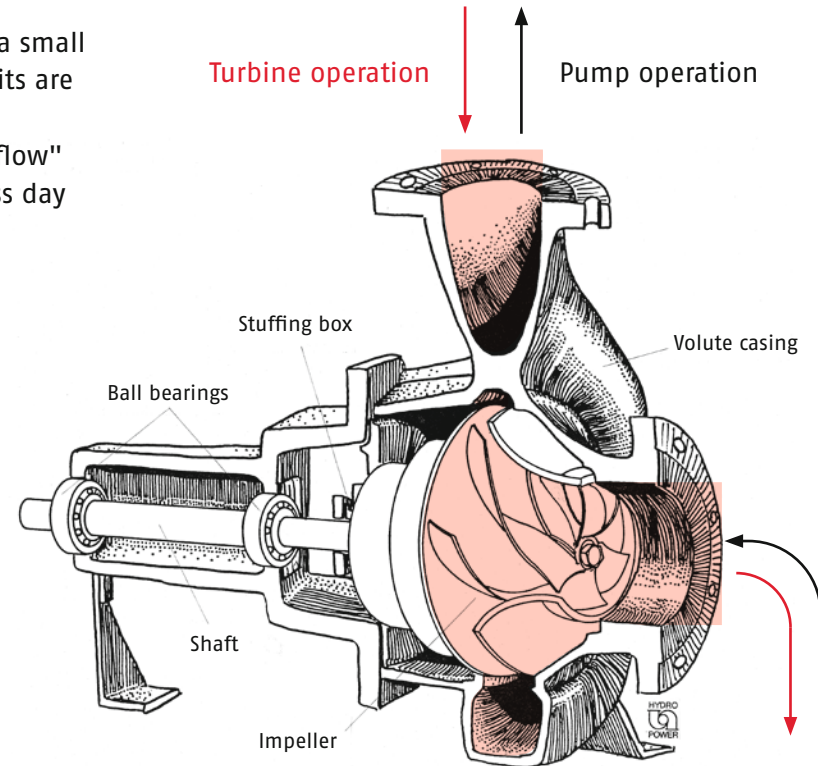

The conversion factor "BEP pump" (BEP = best efficiency point) to "BEP turbine" depends on the specific speed. The conversion factor ranges from 1.2 – 1.4 for pumps of average head 10 – 80 m.

Pump manufacturers shall be asked to submit quotations with turbine curves.

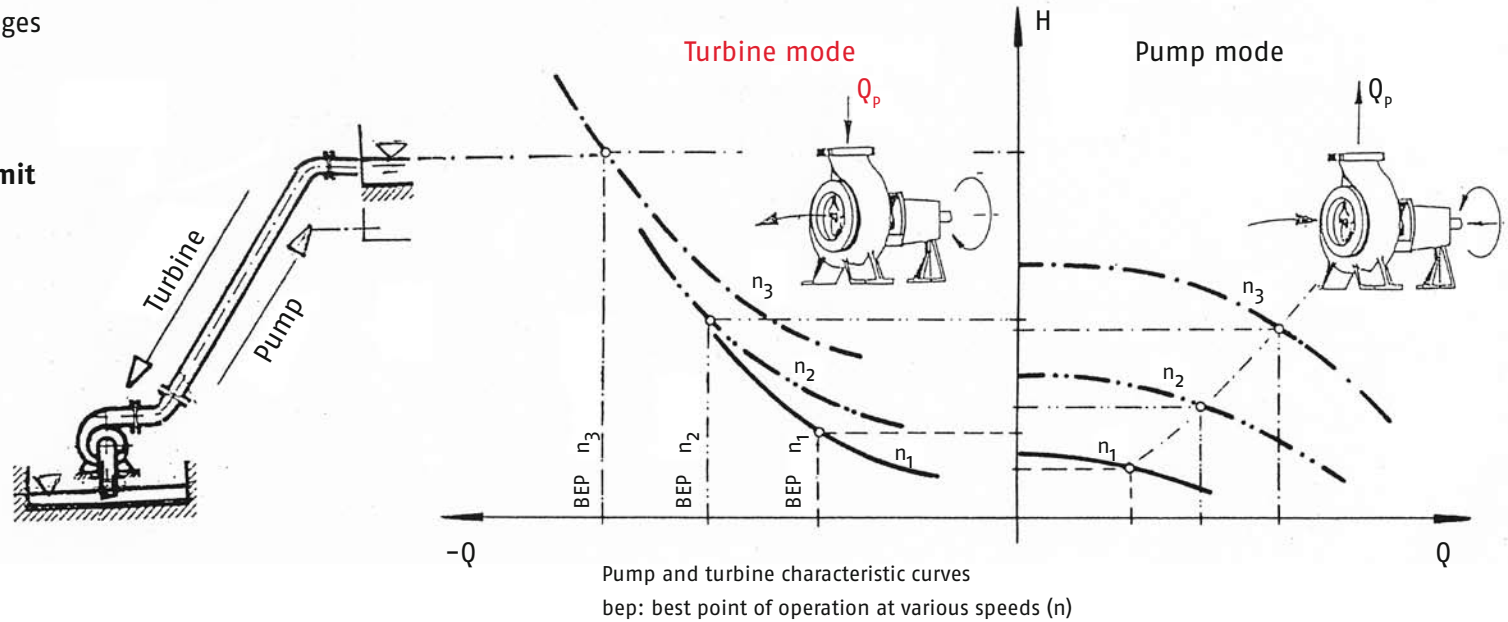

List of plant components – Wedge belt drive PAT (example)

Item	Part	Specification	Quantity	Supplier
1.	Pump as turbine (PAT)	CPK-200-315	1	KSB
2.	Synchronous generator 38 kVA		1	
3.	Wedge belt	SPA 2000	5	Fenner
4.1	Pulley (generator)	Diameter 150	1	Fenner
4.2	Bush (generator)	Diameter 55	1	Fenner
5.1	Pulley (turbine)	Diameter 224	1	Fenner
5.2	Bush (turbine)	Diameter 50	1	Fenner
6.	Base frame (turbine)		1	Local manufactured
7.1	Base frame (generator)		1	Local manufactured
7.2	Slide rail		2	Local manufactured
8.	Electric load controller	ELC 35 kW	1	GP. Electronics
9.	Butterfly valve	DN 300	1	St. Gobain
10.	Bend	DN 300	1	St. Gobain
11.	Flange, welding neck	DIN 2633, DN 300	2	
12.	Flange, welding neck	DIN 2633, DN 250	1	
13.	Flange, welding neck	DIN 2633, DN 200	1	
14.	Dismantling piece	DN 300	1	Straub
15.	Cone, divided	DN 300/750 – 800	1	
16.	Cone, divided	DN 200/300 – 200	1	
17.	Cone, divided	DN 250/320 – 200	1	
18.	Pipe	DN 320 – 2000	3	

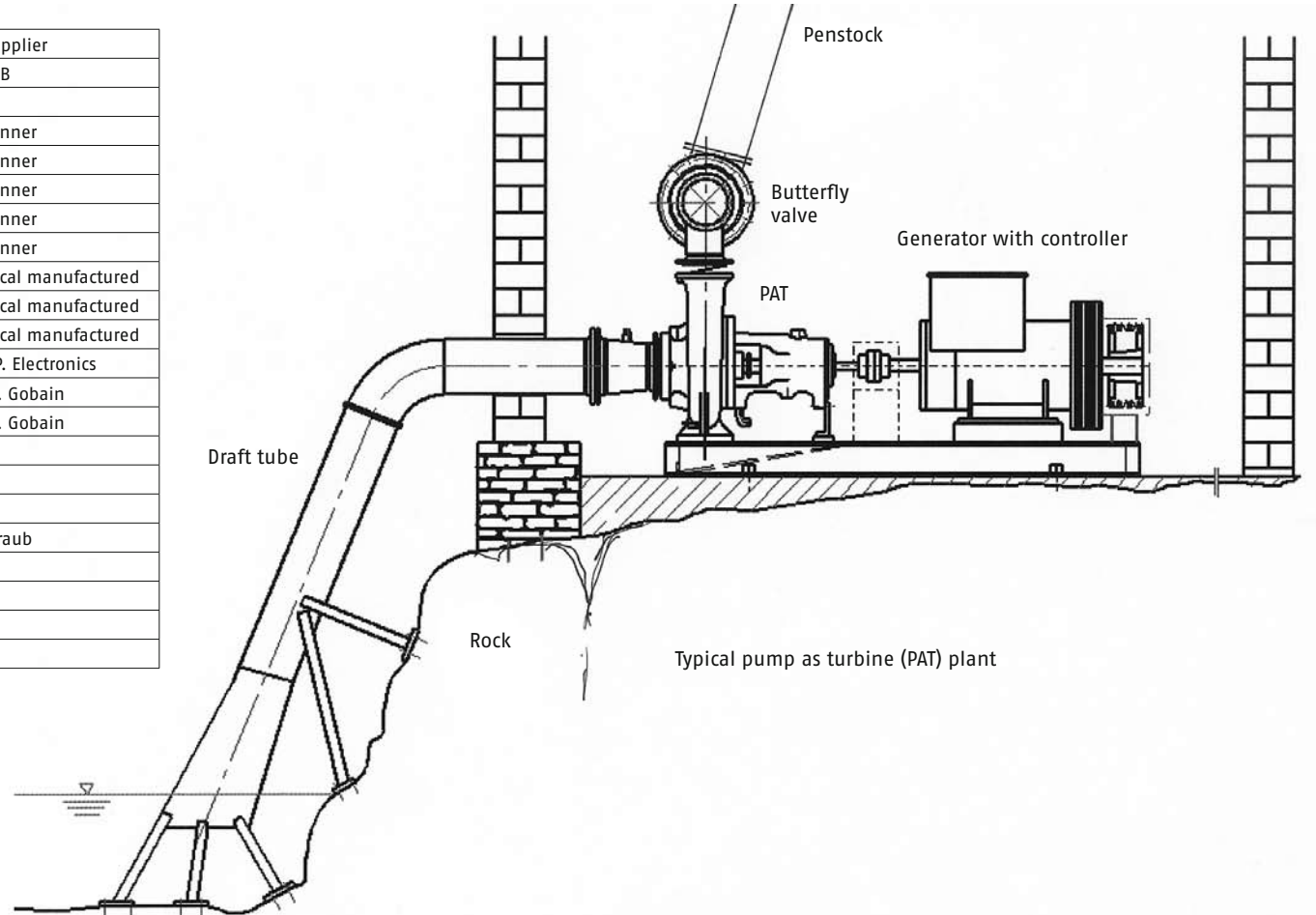

8.4 Turbine choice

Checklist when selecting PAT:

- > Check if there is sufficient water flow to cope with the approx. 30% of deviation from best point of operation (BEP).
- > If water flow exceeds BEP select two or more PATs to cover wide operation field.

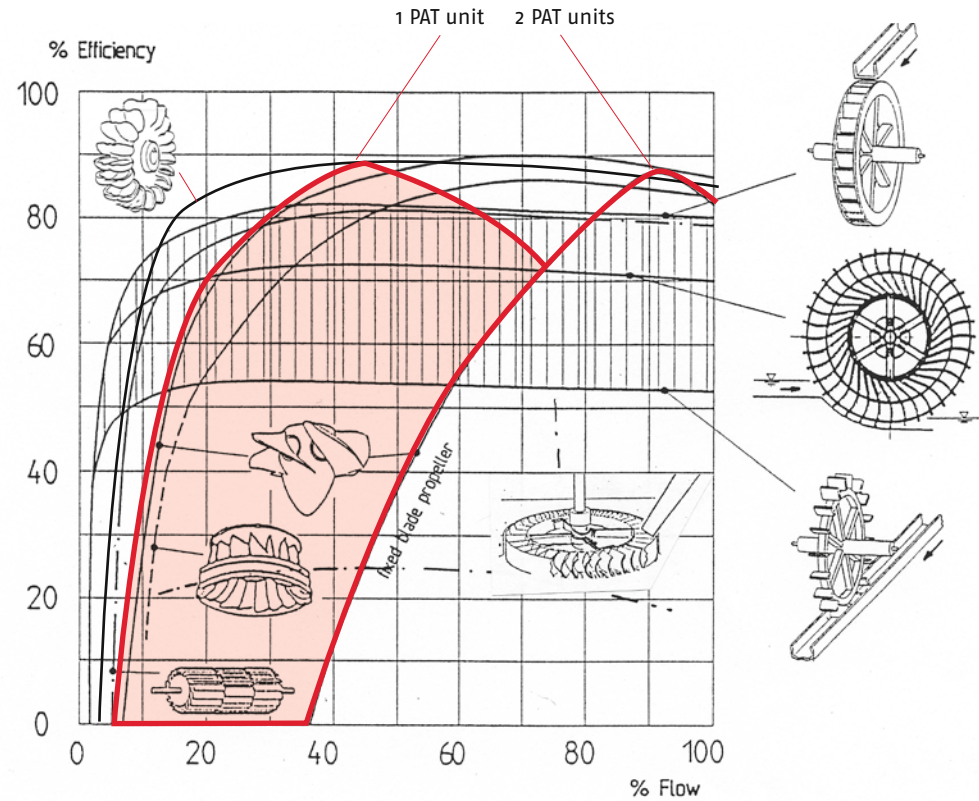

Typical efficiency curves of turbines and water wheels

Choice of turbine and plant equipment

When choosing the turbine manufacturer by tender or quotation make sure he is reliable, competent and shows good quality of workmanship.

The manufacturer – as your partner – is responsible for correctness of plant data and has to make sure that all essential data is clearly indicated on the machine plate (see example).

Instructions, documentation and spare part list should be part of the delivery.

Type / Data plate

Manufacturer	
Adress	
Type	
Size	
Machine No.	
Year	
Head	m *
Flow	l/sec. **
Power	kW ***

* Head refers to net head that can be measured at turbine

** Flow can be measured in the penstock

*** Power refers to mechanical shaft power – not electric power.
(to be measured by brake at shaft)

9. POWER UTILIZATION

9.1 Multi-purpose

In the long history of water mills the grinding mill has developed into a universal power source:

From the prime use in agro processing (threshing, shelling, hulling, expelling ...) the power source was as well used for any kind of processing and industry; there were saw mills, paper mills, powder mills, ... even steel mills ...). Finally, generating of electricity is the most common and up to date water power use. In our environment of remote locations optimal power utilization has to be evaluated on the base of demand and resources.

There is a trend towards replacing water wheels by turbines, due to today's demand for direct electrification.

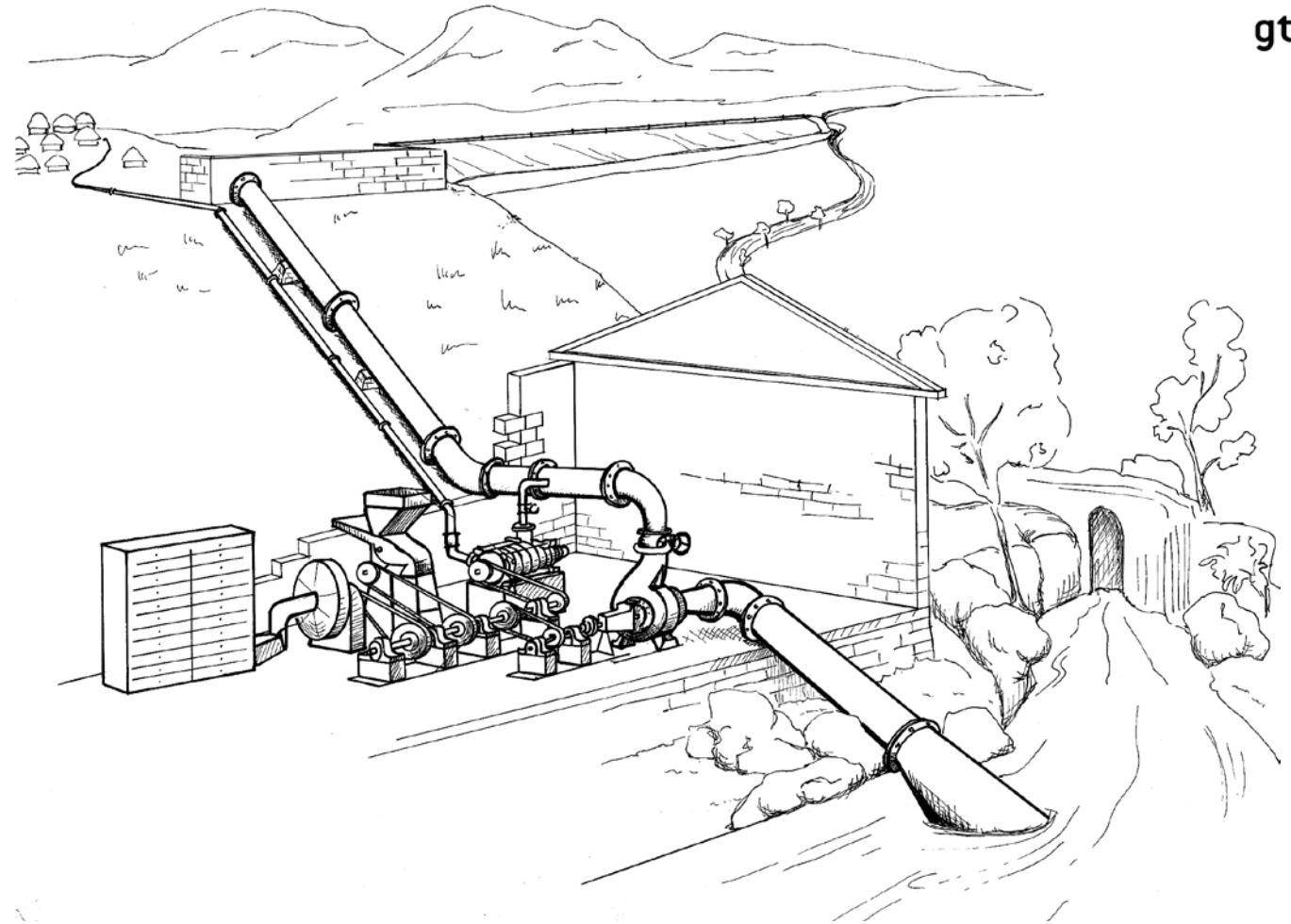

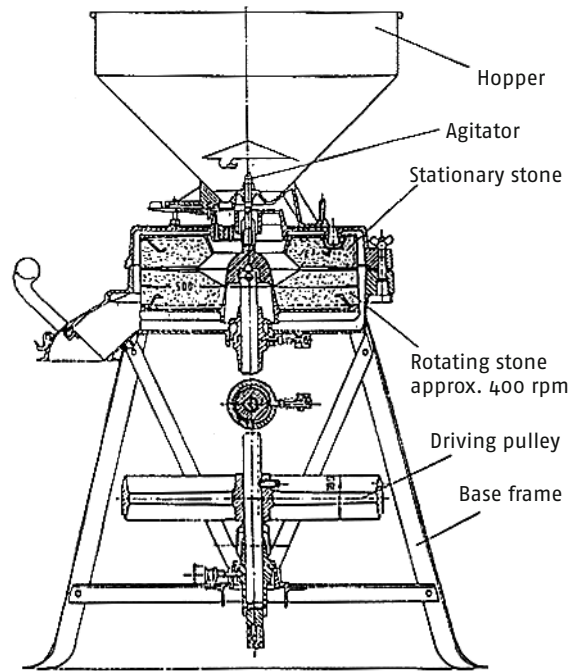

Horizontal stone mill
 – also built with vertical stones.
 Most common in Ethiopia

Hammermills driven by water turbine via crossed belts

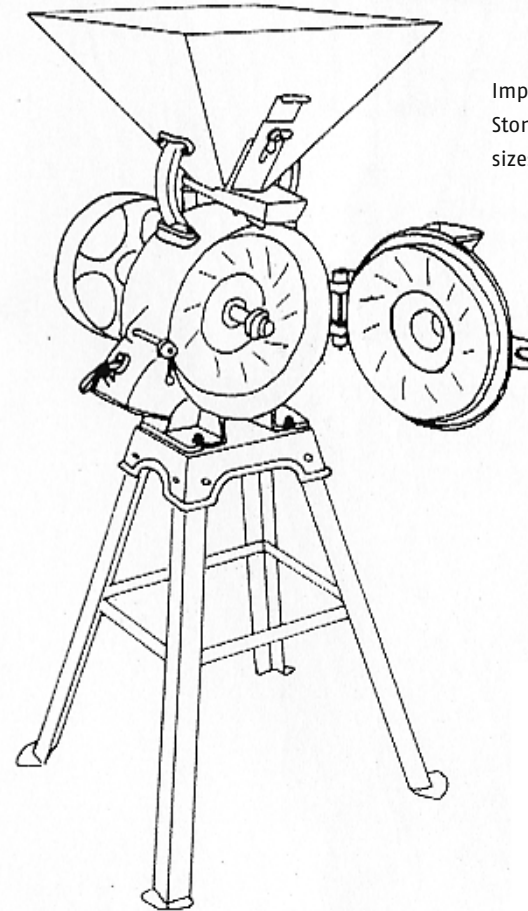

Imported vertical mills are common, too.
 Stone mills are locally manufactured in sizes of 3–5–7, 5–10–20 kW

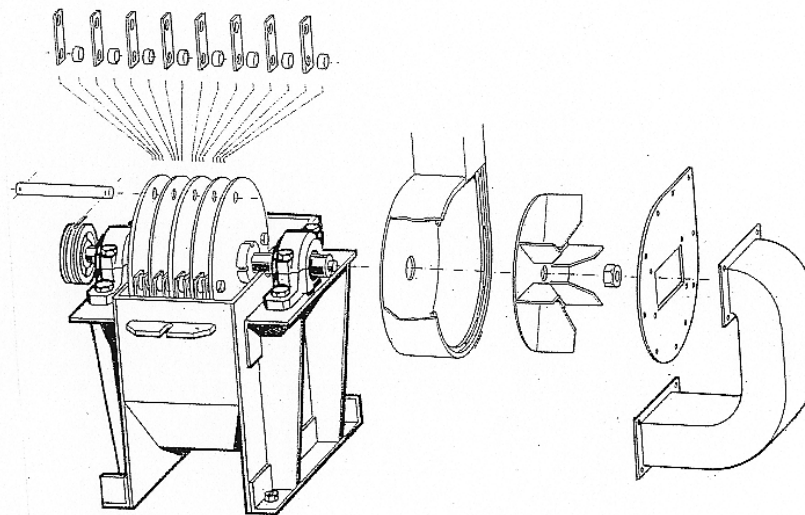
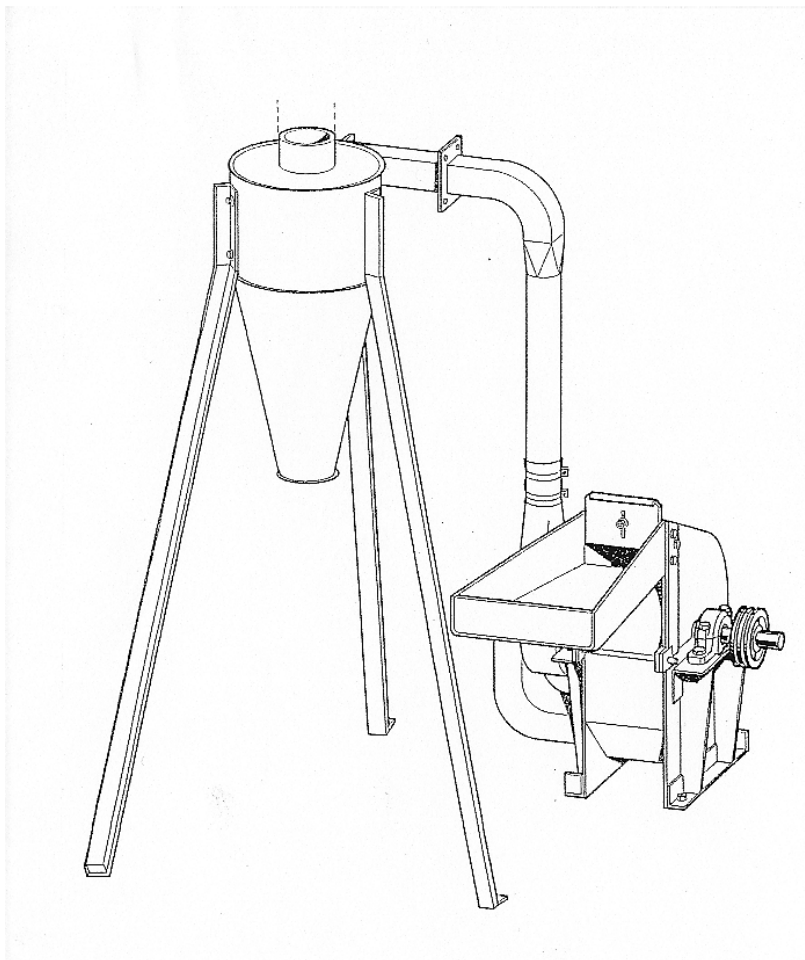

Hammermills are widespread in East Africa, mainly Tanzania, Kenya, Mozambique and Zambia.

The milling principle:

The grain (maize, wheat, millet, dried cassava etc.) is fed into the feeder and directed towards the loosely fitted hammers that operate at high speed, smashing and pulverizing the grain. A blower directs the material to the cyclone for separation.

9.2 Generator, retrofitted

It is most popular nowadays to retrofit existing water mills with generators, replace them, or install modern turbines with **synchronous** generators for 2 or – preferably – 3-phase 220 / 400 V electric supply.

Depending on the power of the mill, the demand and the technical and financial means, the following systems may be introduced:

- flour mill operating in day time (as before)
- and/or generator operating in evening (and night)
- or the generator is operating round the clock for full electrification security:
 - a) daytime productive use
 - b) evening lighting

More details in chapter 9.5, page 101.

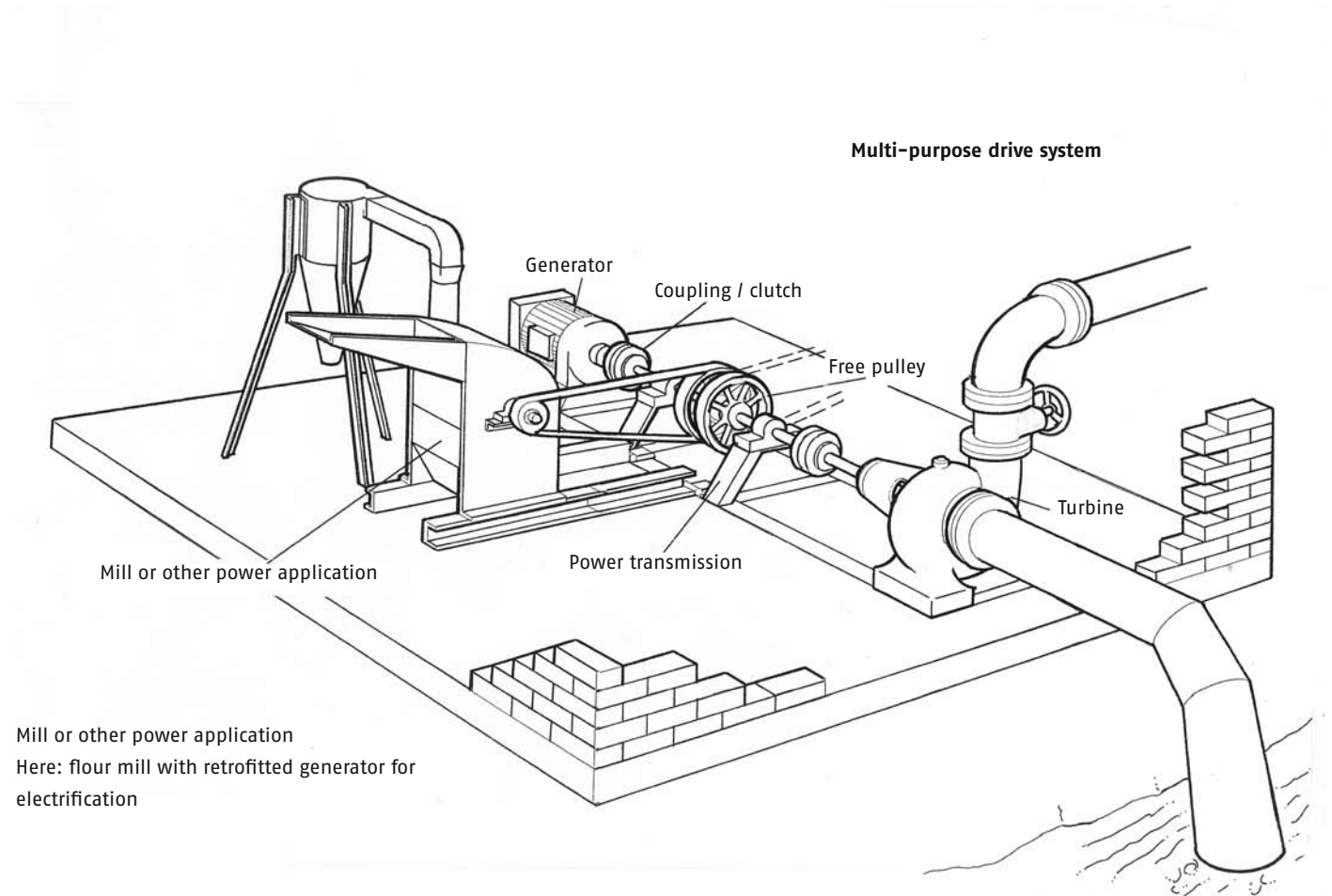

Mill or other power application
Here: flour mill with retrofitted generator for electrification

9.3 DC-Electricity

Generally, mechanical flour mills can be equipped with a v-belt-drive car-dynamo: A car-dynamo is fitted with a self-regulatory system that supplies 12V (24V) for car lighting and battery charging. With this device, batteries can be charged while the mill is operating. Besides providing light for the mill and the surrounding area, batteries can be removed and taken home, or to shops, restaurants or discos, to provide light and power.

In the homes any "home system" of (12V DC) as known from solar systems will improve living conditions. Energy saving devices are most important for high efficiency.

Integrated in
car-dynamo

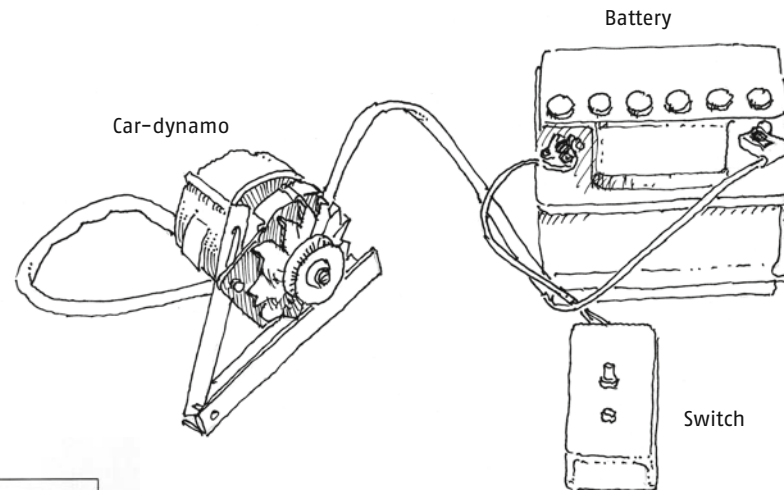
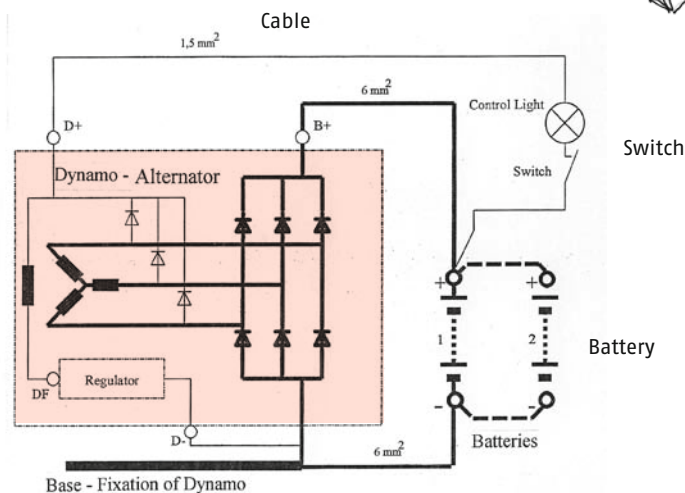

Note:
Car dynamo and battery are designed for limited lifetime and require replacement after their service time.

9.4 Battery based DC electrification

For scattered settlements that are not connected to the National Grid, DC (direct current) supply from batteries – as practised in solar power systems – is an appropriate solution for small electric supply.

Advantages when batteries are charged by hydro-power:

- > Low investment for charging device (car dynamo).
- > Low power diversion of mill or: smaller/pico hydro is a suitable power source.
- > Portable batteries can be transported to any distance.
- > Material, components and technology is locally available.
- > For application in houses, the technology of solar home systems can be applied, energy saving 12 V bulbs, radio and small devices can be connected.
- > With DC/AC converter 220 V small appliances can be used.

Disadvantages:

- > Replacement of dynamo and battery after 3 to 5 years.
- > Limited power, in spite of short term peak load.
- > Inferior to (220//400 V) AC grid supply.
- > Transport of battery to charging station.

Energy option in remote location (Source: Worldbank, GTZ, Hydro Power)

	Availability	Appropriate for:			Price \$/kWh	Comment
		Light	Radio	Power drive		
candle	++	+	-	-	0,15	common for poor people
kerosene	+	+	-	-	0,70	common for poor people
dry cell battery	++	+	++	-	5 – 300	expensive, diff. Quality
lead battery *	+	++	++	watermill, direct	0,6	easily available
central charge	0	++	++	-	2,5 – 3,5	limited introduction
central charge by Hydro	0	++	++	-	1,50	limited introduction for remote locations
photovoltaic *	0	++	++	-	1,5 – 4	expensive
diesel (gen.) *	+	++	++	++	0,5 – 1,8	el. AC and DC possible
water power *	-	++	++	++	0,3 – 2	el. AC and DC possible, high initial investment

* systems proposed für electrification improvement

++ very good / + good / 0 medium / - poor

9.5 'Stand-alone' – AC power generation with 'mini grid'

Introduction of AC (alternating current) electrification is easier where there is a tradition of watermills, i.e. in mountainous regions of Nepal, India, Pakistan, Afghanistan, and recently, Ethiopia. Often flour mills were abandoned and replaced by turbine generator units – for providing light mostly.

Optimum solutions combine the operation of the flour mill for day operations and generation of light in the evening.

Well-planned systems combine the demand of the community with the available hydro potential.

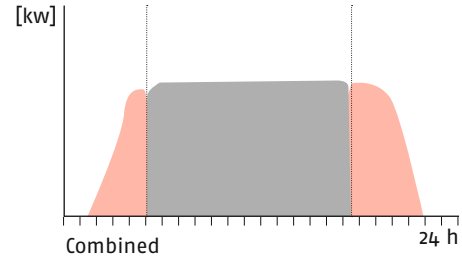
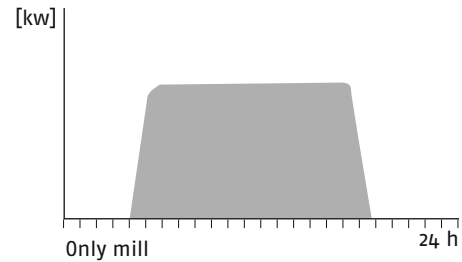
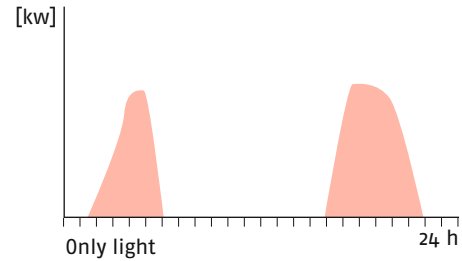

Evaluation of demand / consumption during one day (24 hours)

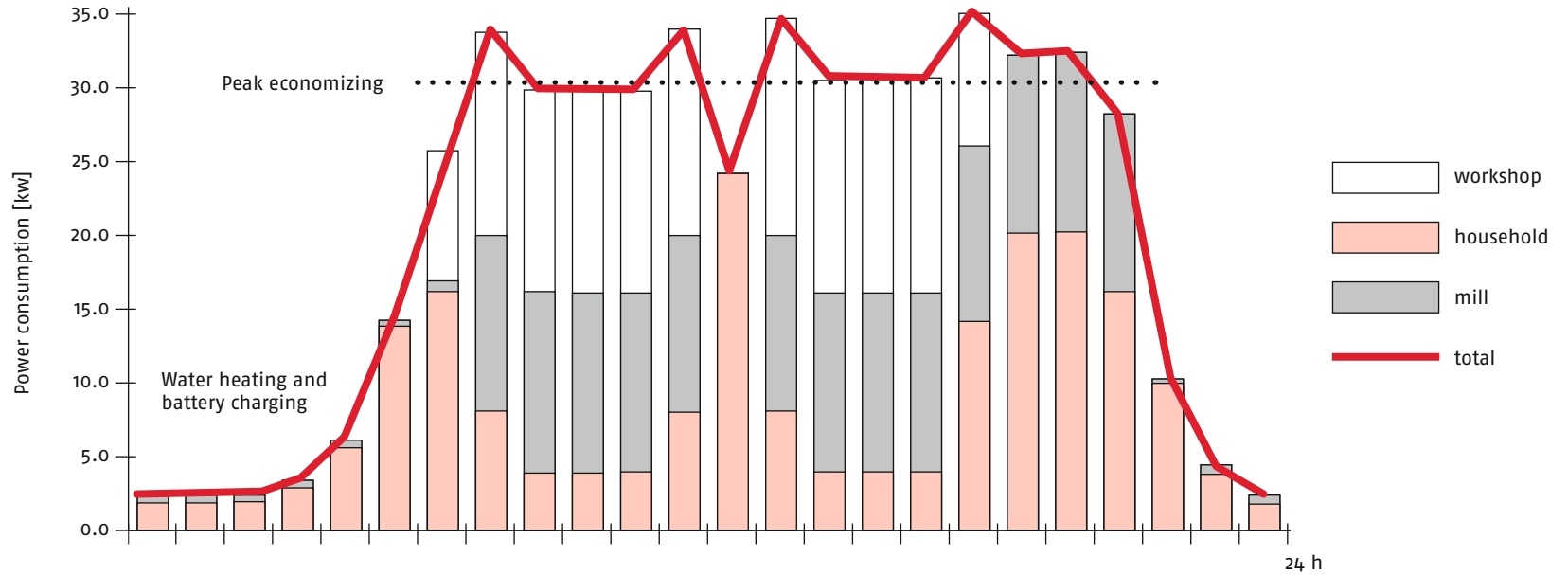

Source: SKAT

9.6 3-phase AC synchronous generator and drive system

is basically used for stand-alone (isolated) plants. Speed and frequency are synchronous. At 50 Hz the following synchronous speeds result: 3000 – 1500 – 1000 – 750 rpm.

If equipped with AVR, Automatic Voltage Regulator, voltage is controlled.

Single phase AC asynchronous generator may be used in small systems below 10 kW

AS – Asynchronous (induction) generators are used in grid connected systems from where the exciting current is drawn. When used in stand-alone plants, capacitors or devices for excitation are required.

High speed turbines as Pelton, PAT, etc. can be designed for direct drive at synchronous speed. Advantage: simple arrangement, no radial load on bearings.

Direct drive

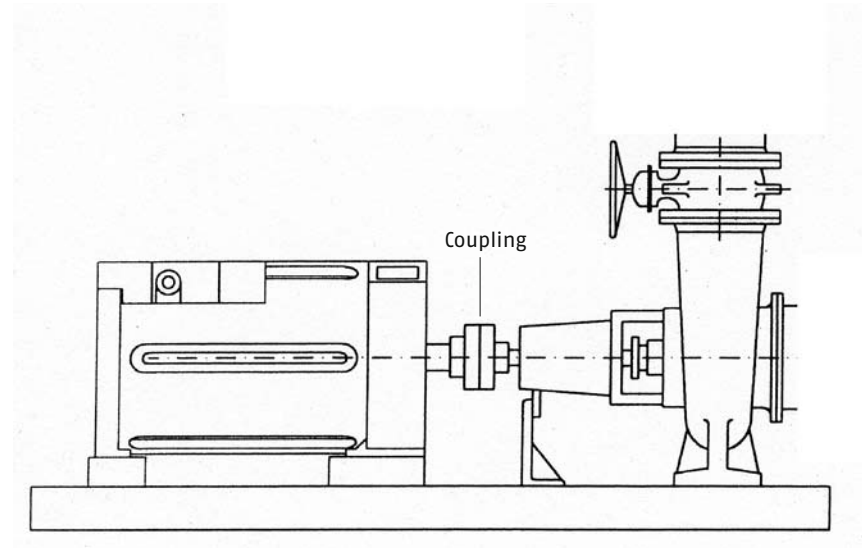

Synchronous generator with pump as turbine (PAT)

Belt drive

For dimensioning: Use manual and catalogue of belt suppliers who serves the local market.

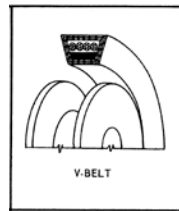
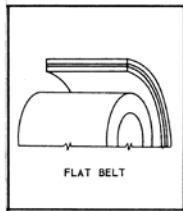

Flatbelts:

- > require high tension and cause high load on bearings
- > leather belts with clamped connections are commonly used inspite of their disadvantages
- > for modern synthetic belts inquire with local suppliers or consult internet sources i.e. HABASIT, SIEGLING.

V-belt (size ... A, B, C ...):

Wedge belt (size ... SPA, SPB, SPC ...)

- > adjust to locally available length
- > use catalog/diagrams for sizes and numbers of belts

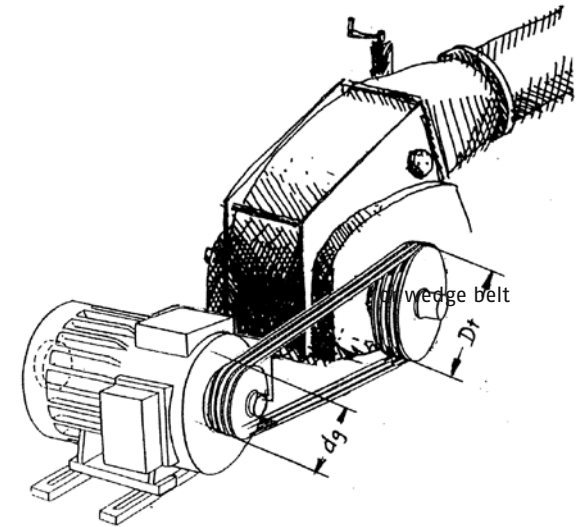

Belt drives are used to adjust the turbine speed (n_t) to the generator speed (n_g) by the relation:

$$\frac{D_t}{d_g} = \frac{n_g}{n_t}$$

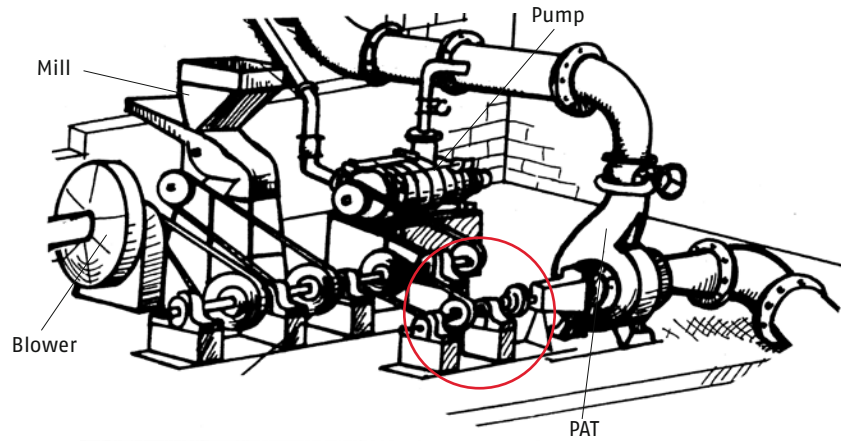

Transmission shafts with bearing pedestals are applied for:

- > high radial load on bearings
- > for power distribution (here: multi-purpose use of power)

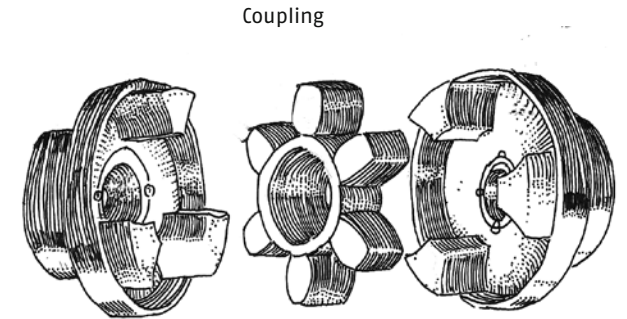
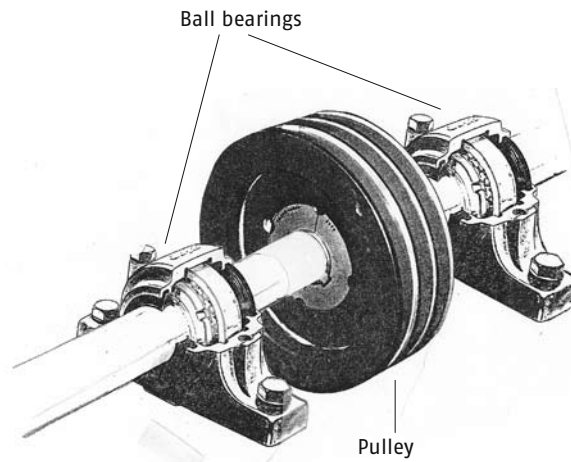
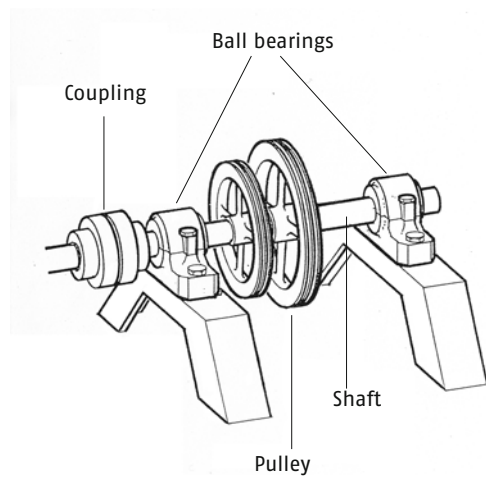

9.7 Categories of control *

Depending on size of plant, technology and availability, even micro plants up to approx. 50 kW should comply with minimum requirement for control – shown here.

- > Primitive system may depend on hand-regulated turbine valve for control
- > Recommended is ELC, Electric Load Controller especially for 'quality' of electricity when productive power is used.
- > Involve manufacturers in planning, but make sure they obtain correct information.

* 3 categories ABC are proposed by SKAT, 'Village Electrification'.

Standard electrical control system category A

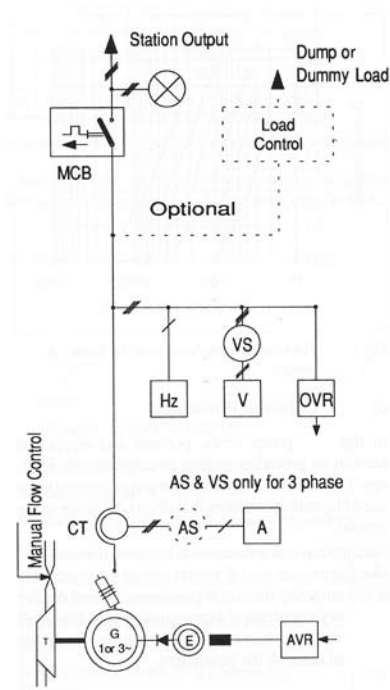

Single line diagram for the control circuit of category A.
The load control is optional

Components	
AVR	Automatic Voltage Regulator
A	Amp. Meter
AS	Amp. Selector
CT	Current Transformer (for A)
E	Excitor of Generator
T	Turbine
G	Generator
Hz	Frequency Meter
V	Volt Meter
VS	Volt Selector
OVR	Over Voltage Relay
MCB	Miniature Circuit Breaker
ELC	Electric Load Control: Dummy load is switched on for balance when generator power is bigger than actually used power – maintaining constant voltage on frequency.

9.8 Grid

A 'mini grid' served by a hydro power station is only justified if the National Grid is far away (> 20 km) and a power connection to the settlements will not be installed in the foreseeable future.

If the site is suitable for the installation of a mini grid more information has to be collected to plan community electricity supply.

See details: 'Scout Report' (see chapter 12, page 113) and 'implementation plan' (see chapter 12.3, page 114).

Conditions:

- > The grid area must be determined.
- > Experienced experts must guide the project.

Grid extension to scattered houses or hamlets may be too expensive. **In this case** 220 V charging stations with kWh meters can be installed in shops, fuel stations, garages, mills etc. to serve battery charging for remote locations. Charging may be done preferably in night time when surplus electricity is generated.

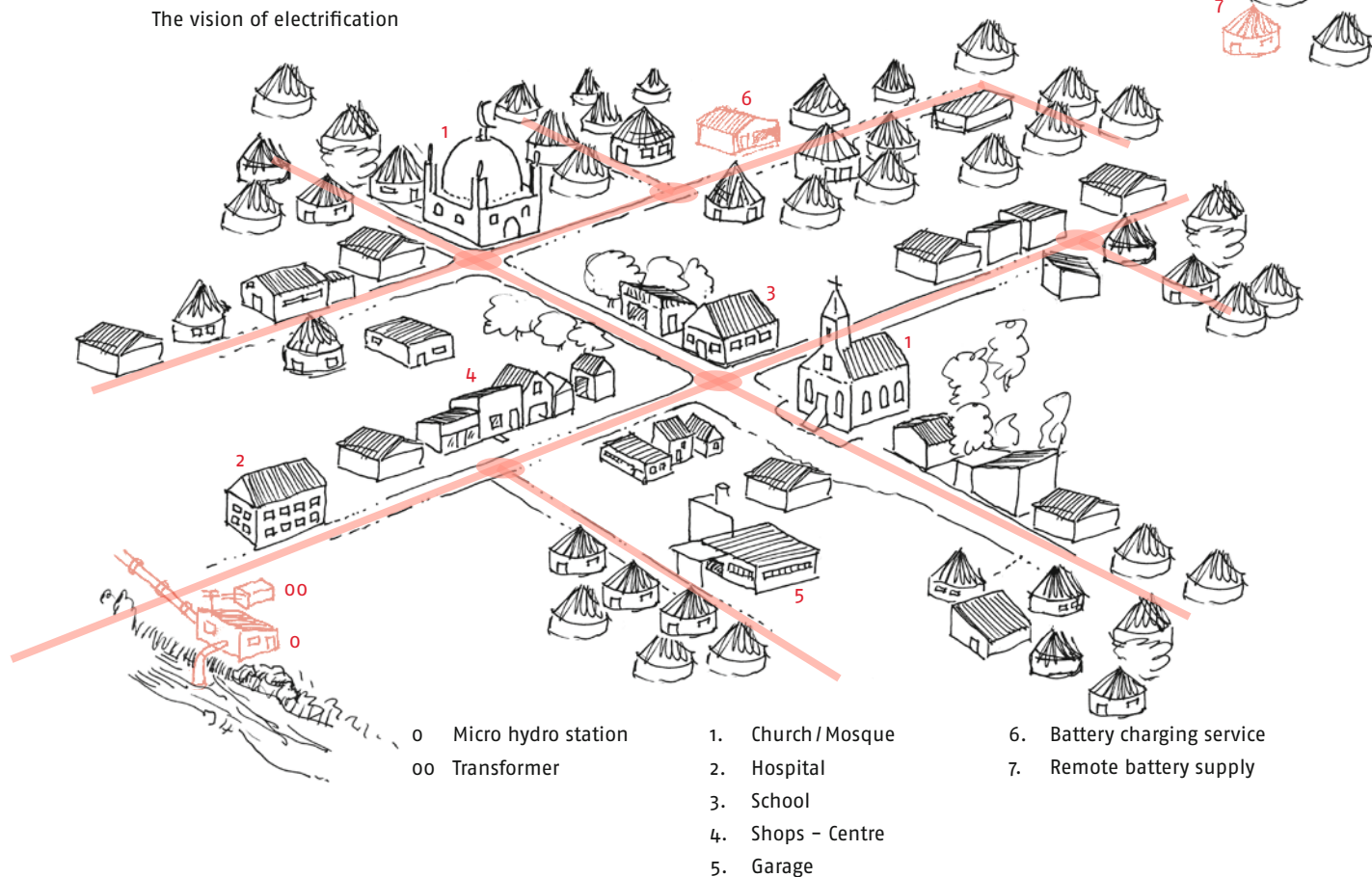

9.9 Concept for the mini grid

All electric installations have to comply with the standards of the "National Electricity Supply (NFS)".*

- > This is required for safety and standardisation reasons
- > In case of grid connection at later steps of development, the mini grid must be 'compatible' to be connected to the NFS

Therefore:

- > Plan with the experts of the National Grid and execute with their contractors

* different names and organisations in each country

*References: Ethiopia: EEPCCO, Tanzania: TANESCO

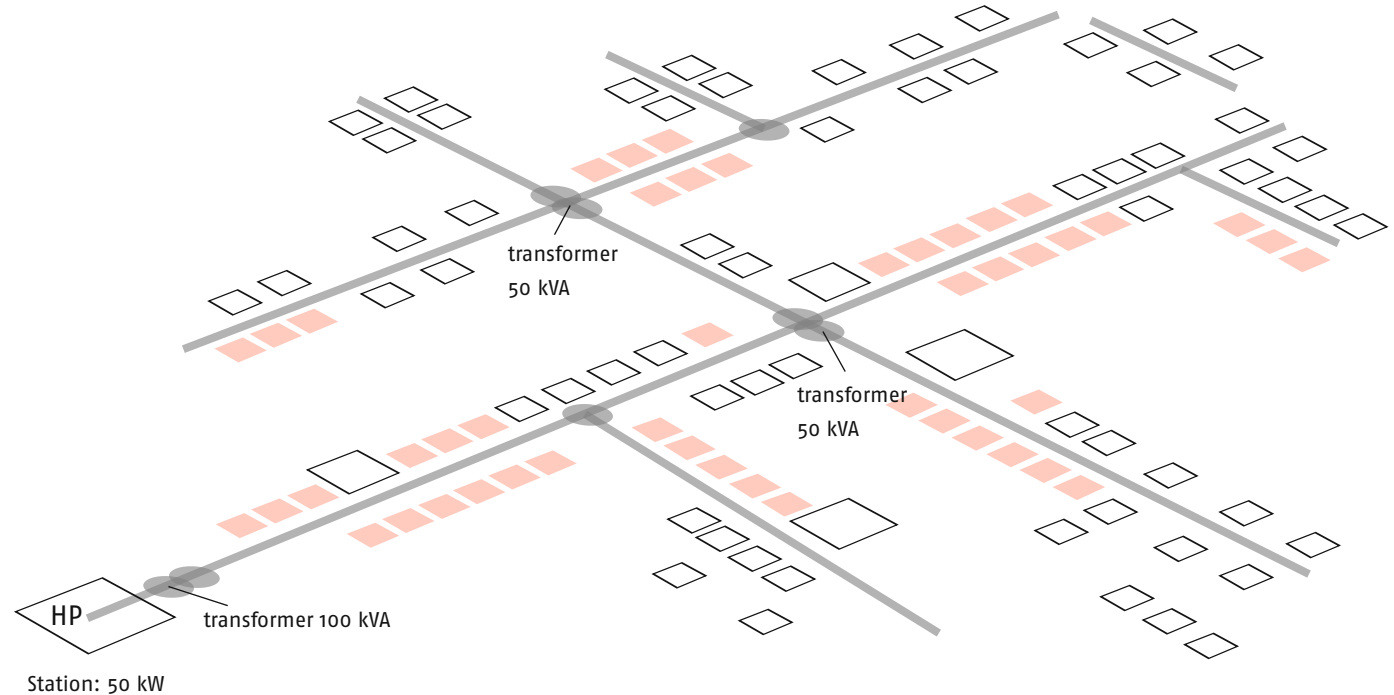

- ◇ Initial connections
- ◻ Extension phase

Experience:

The community expands/grows along the transmission line!

9.10 Components of power distribution

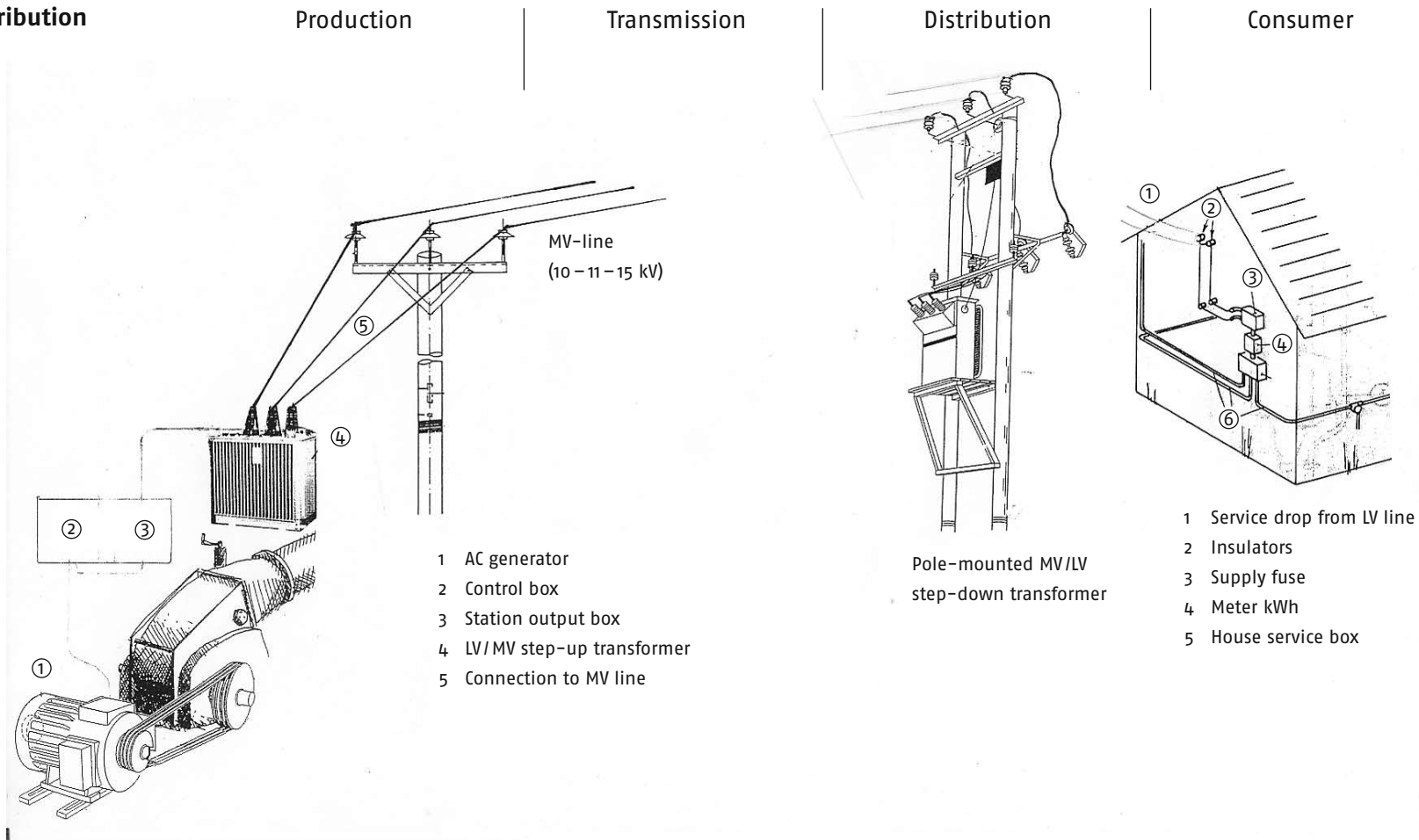

10. NATIONAL GRID OR COMMUNITY MINI GRID

The high initial investment for a hydro based stand alone supply with the mini grid is only justified if

- > The grid is far away or will not reach soon
- > Only poor interrupted supply in the nearing grid is obvious
- > Feeding the generated electricity into the grid is guaranteed, once the grid reaches the community

Further

- > The site is technically feasible for hydro development and has a potential to cope with the community demand.
- > The community is determined to enter with the substantial self-help contribution and
- > accepts the guidance of the project development sponsor.

The development sponsor will help in the organisation, technical and financial needs – where the community has not the experience to handle such a project alone.

Guidance for tariff structure to achieve a sustainable CECO, Community Electric Committee or Cooperative:

General

- > Tariffs are determined (and evaluated) by the CECO with community participation.
- > Tariffs should be below the national tariff of grid supply
- > No free connections
- > Customers are compelled to use energy efficient devices and accept CECO's energy management

Proposed 3 tariffs

T 1: *"Bring light to all"*

Charge by bulb (per household)

T 2: *"Productive use brings economic development"*

Charge according to meter where power connection is provided.

T 3: *"Social service for the community"*

CECO committee with participation of the community sets this tariff ..., caring also for the poorest in the community.

The diagram below gives an overview how the project is shaped by forming a legalized set up, the CECO, Community Electric Committee or Cooperative.

ASSIGNMENT / DUTIES

Project initiator
coordinates stake holders
later: annual meeting

THE ORGANISATION OF CECO (COMMUNITY ELECTRIC COOP./CO.)

Stake holders – 'Project Initiator'
> District/Regional (Dev.) Authorities
> Sponsors, Donors, Development Bank, ...
> Diocese Dev. Dept., NGOs, ... active in area

THE PROGRAMME AND SUPPORT

Regional Hydro Development Programme
or competent sponsor if programme does not exist

CECO

Community electric committee – or cooperative
elected members (by council, community)
Chairman: Project Supervisor
Dep. Chairman: Secretary/Assistant

Support

Programme
planning and service centre

Responsible for implementation – later: operation
Chairman, Deputy and all members act in honorary capacity

Duties:
Technical-, organisational-, financial control, tariff setting

Electrio- mechanical and civil installations
operation and maintenance (O+M)

Distribution (grid) and connections O+M
customer installation control

Financial and store recordsexpenditure and revenues,
monthly statement and budget

> Power station operator
> Assistant (for shift)
> Security (night watchman)

Distribution operator
1 Assistant for installations

Accountant financial manager
Assistant (collector and billing)

Electromechanic, civil
plant service

Distribution and customer service

Audit
Financing control

11. ENVIRONMENT PROTECTION BY THE COMMUNITY

Degradation of the natural environment, due to expansion of agricultural land use, deforestation, and growing erosion, has led to the reduction of water flow in dry seasons. This endangers the water power source.

To ensure the sustainable operation of a mill run by hydro power or electrification the water resources in the whole catchment area have to be protected. As a (basic) principle, the National regulations for environment protection should be adhered to, e.g. the Ethiopian Water Resources Management Policy – or relevant policies rules or regulations of the countries.

To apply the same on a village community level, a practical, simplified system may be applied – the so-called Water Resource Action Plan, or WRAP.

This plan requires, as a first step, the assessment of the environmental impact and the identifi-

cation of measures to be taken. After that, all parties involved – Forestry, Agriculture, Irrigation, Water Supply, Water Management, Watermills etc. – come together to draw up a protection plan.

The process will be coordinated by one of the relevant organisations involved in the protection of the environment.

In the 'Water and Resource Action Plan' the commitments are laid down and have to be agreed upon by the community. These may involve reforestation, protection of water sources and swamps, limitation of agriculture in sensitive areas, agricultural forestry, erosion protection etc., depending on the identified areas of the assessment.

Reference WRAP © by hydro power 2007 – 2 pages out of 9 pages summary.

Water and Natural Resources Protection at Community Level

- > Application of national resources and policies and acts on practical level with community.
- > Community determination for water and resource action plan (WRAP) is the condition for the establishment of MHP + electrification.
- > MHP sponsors and community development organisations initiate and guide the process.

Aim → The water and natural resources allow for sustainable living in the protection area

February 2007 WRAP Water and Resource Action Plan

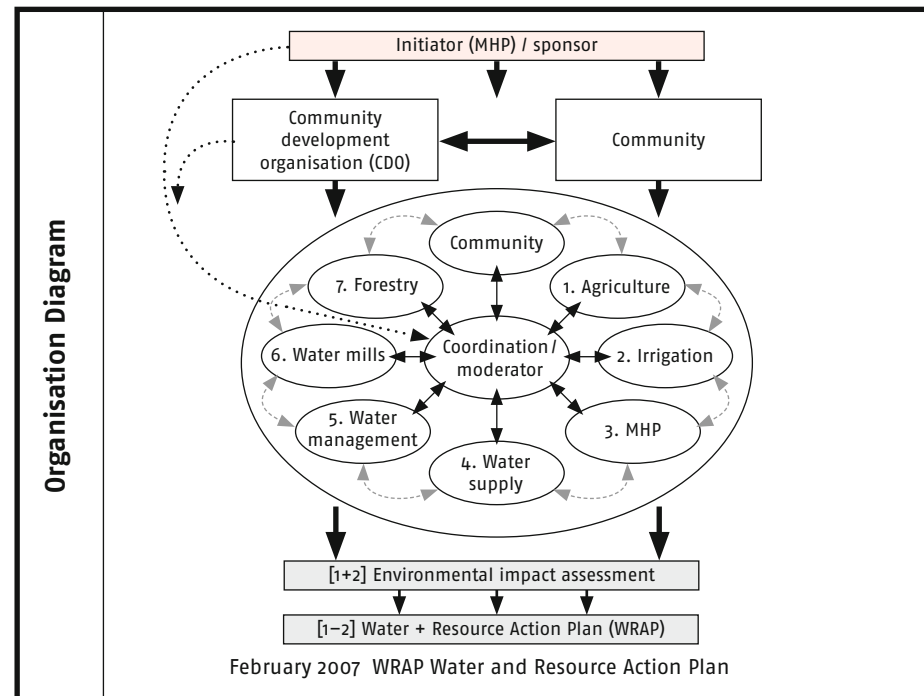

12. THE ROLE OF THE HYDRO SCOUT

The Hydro Scout's task involve:

- > collection of information
- > guiding of teams / leadership
- > evaluation of ideas, suggestions and plans

The Scout reports

(if possible use locally available formats)

12.1 Community information and electricity demand

12.2 Project preparation

12.3 Project implementation schedule

12.4 Fact sheet – technical features

12.1 Community information and electricity demand

Before starting your project assess...

- > location and access to village / site, distance to main road, grid GPS coordinates
- > infrastructure – roads, water supply, generators for light and power
- > business and market situation*, number of shops, workshops, potential power consumers
- > co-operation with development projects
- > potential organisations for project handling
- > institutions such as schools, health centre, community centre, religious centre
- > types of settlement, sketch with houses, number of households*
- > community / village, establish contact
- > initiative or progress for hydro / electricity
- > community's and leaders' readiness for project and self-help contribution
- > expectations of community for demand of light and power with estimates*.
- > persons interviewed

- > leaders with contacts to authorities
- > activities of NGOs or authorities in development projects
- > potential of experts, masons and other craftsmen
- > availability of material, sand, gravel, stones, bricks, etc.
- > leadership structure

Organise round-up meeting with the village leadership:

- > expectations of community
- > expectations and needs of the women, communicate with representative.

Remember: this visit is for information only. There is no promise or commitment at this stage.

* The 'Scout Report' contains the essential data from above and the expected electricity demand. Use formats – if available.

12.2 Project preparation

Apart from the complex technical requirements as outlined in the scout guide, economic, legal and administrative aspects are to be considered.

Thus, after establishing the basic technical data (hydraulic data, demand output, figures) and drafting a project outline, contact the authorities for the following aspects in order to establish the overall feasibility of the project:

- > permission for power generation, conditions and tariffs
- > land use, ownership, transmission rights
- > water right licensing, environmental restrictions
- > ecological impact, influence on farming, fishing, forestry, landscape, protected areas etc.
- > permission for planning and construction

Further check / prepare:

- > financing facilities, subsidies, government support, feasibility
- > economic evaluation

As government regulations vary widely in different countries the procedural issues have to be examined locally.

12.3 Project implementation schedule

- > information of community with suggestion of project (MOU)
- > planning of project → Scout Guide
- > clearance with authorities
- > financing arrangements
- > community organisation
- > agreement / contract with community and participating partners
- > project implementation
- > contracts with suppliers and contractors
- > supervision and execution of self-help work
- > deliveries and construction
- > organisational set-up for power supply
- > commissioning, training, handing over

FACT SHEET MHP APPLICATION

Country: Population: Country surface: Currency: Exchange rate:		Project location Region / district: Village / place: Name of river:		METROLOGICAL INFO Seasons: HYDROLOGICAL INFO Gauges:	
SYSTEM INFORMATION Gross head: [m] Design flow: [l/s] Total capacity: [kW] Type of turbine: Load factor (% year): [%] Possible local service: lighting / agro product processing		TECHNICAL INFORMATION General layout 			
System components Intake structure / weir Weir canal sand trap Flushing structures Penstock Power house Turbine(s) Generator(s) Transformer(s) Distribution grid					
Initial SHP investment Costs [\$/kW]: Status of project development:		> Turbine technology locally *available: *not available:			
Estimated number of potential customers:		RIVER CHARACTERISTICS mean flow: [m ³ /s] min. flow: [m ³ /s]			
Estimated potential market:		STRUCTURES canal length: [m] flow: [m ³ /s] velocity: [m/s] slope: [°/100°] power house:			
Purpose of installation:		REMARKS: NUMBER OF TRANSFORMERS TRANSMISSION LINE: length: [m] voltage: [kV] LOCAL DISTRIBUTION GRID: length: [m] voltage: [kV]			
FACT SHEET #		Remarks:			

BIBLIOGRAPHY AND SOURCES

ALL FIELD OF MHP INCLUDING CIVIL WORKS

HARVEY, ADAM; *Micro-Hydro Design Manual*, 1993
ITDG – Practical action, UK
Comprehensive, valuable reference covering all MHP aspects

INVER SIN, ALLEN; *Micro-Hydropower Sourcebook*, 1986
NRECA, USA
Covering all MHP fields, early examples

SHADMON, ASHER; *Stone An Introduction*, 1989
ITDG, UK

www.microhydropower.net

TURBINES

SCHEUER, HELMUT; METZLER, R. YODER, B.;
Small Water Turbine construction manual, 1980
GATE/GTZ, Germany
The early crossflow version 205

SKAT; *Crossflow Design Type BY5/T7*, 1985
Design drawings
SKAT (ENTEC), CH

ENTEC; FISCHER, GERHARD; *T15 Turbine Documentation*, 2000
License ENTEC, CH

THAKE, JEREMY; *Pelton Turbine Manual*, 2000
Design, manufacture and Installation
ITDG / Practical Action, UK

SKAT; EISENRING, MARKUS; *Micro Pelton Turbines*, 1991
SKAT, ENTEC, CH

CHAPALLAZ, J-M., EICHENBERGER, P., FISCHER, G.;
Manual on Pumps Used as Turbines, 1992
GATE/GTZ, Vieweg Verlag, Germany

ELECTRIFICATION

WIDMER, R., ARTER, A., *Village Electrification*, 1992
SKAT, CH

SKAT; CHAPALLAZ, J-M., ET AL.;
Induction Motors used as Generators, 1992
SKAT, CH

FISCHER, G.; *GovernorProduct Information*, 1990
SKAT, CH

NIEMEYER, P., CICHOWSKI, R. R.; *Freileitung,
Anlagentechnik für elektrische Verteilungsnetze*,
VWEW, VDE Verlag

STANDARDS – EXAMPLES

INTERNATIONAL STANDARD CEI IEC 1116, 1992–10
*Electromechanical equipment guide for small hydroelectric
installations*

MHP STANDARD (up to 30 kW) Mini Grid Programme, 2009,
Guidelines for Feasibility Study of MHP, 2004
ESAP/ AIEEP Project Nepal

NATIONAL STANDARDS (inquire locally)

STANDARD BASED, *Distribution Construction Handbook*,
TANESCO, Tanzania

MANUFACTURERS AND SUPPLIERS

They provide product information catalogues, technical
documentation, manuals as your partner in projects

CONTRIBUTIONS TO THE SCOUT GUIDE

From sources mentioned above,
Wölfle Gunther, Teege Klaus, Civil works
Hydro Power Ing.-Büro, project documentation, manuals and
publications



