

# COURSE HANDBOOK



# ENERGY MANAGEMENT



European Union



german  
cooperation

DEUTSCHE ZUSAMMENARBEIT



**USAID**  
FROM THE AMERICAN PEOPLE

Developed with funding by the European Union, the Federal Government of Germany and the United States Agency for International Development.

This document was produced with financial assistance of the European Union, Federal Government of Germany and the United States Agency for International Development (USAID) by the Nigerian Energy Support Programme (NESP) implemented by the German Agency for International Cooperation (GIZ) in partnership with the Nigeria Renewable Energy and Energy Efficiency Project (REEEP) implemented by Winrock International.



## Energy Management

Course Handbook for a 160-hours training course for engineers

2<sup>nd</sup> Edition • May 2017

Developed in pursuit of conformity with the Nigerian Competency Standards for Clean Energy | Released 2016 in the domain “Energy management”

## Published by

Deutsche Gesellschaft für Internationale Zusammenarbeit (GIZ) GmbH

Nigerian Energy Support Programme (NESP)

2 Dr. Clement Isong Street, Asokoro, Abuja, Nigeria

Contact: Ina Hommers ([Ina.Hommers@giz.de](mailto:Ina.Hommers@giz.de))



## Developed by

Consortium GOPA Consultants – intec with support of Winrock International

Authors: Dr. Helmut Städter André Möller  
Kai Hillebrecht Habeeb Salawu  
Kishan K. Chakarvarti Dr. Emmanuel Ogedengbe  
Josef Buchinger Dr. Albrecht Kaupp

Review: Dr. Albrecht Kaupp  
Felix Nitz  
Lawrence E. Edeke

Editing: Sarah Matthews  
Olatunde Isiolaotan

Layout: Chinedu M. Ibegbulam  
Far-Out Media Design

Project head: Felix Nitz

Photo credit courtesy Far-Out Media Design, 2016.

GOPA Gesellschaft für Organisation Planung und Ausbildung mbH  
Hindenburgring 18, 61348 Bad Homburg, Germany • [www.gopa.de](http://www.gopa.de)

GOPA-International Energy Consultants GmbH  
Justus-von-Liebig-Str. 1, 61352 Bad Homburg, Germany • [www.gopa-intec.de](http://www.gopa-intec.de)

Winrock International  
2121 Crystal Drive, Suite 500, Arlington, Virginia 22202, USA • [www.winrock.org](http://www.winrock.org)



The views expressed herein can in no way be taken to reflect the official opinion of the European Union, Federal Government of Germany or the United States Agency for International Development. The findings, interpretations and conclusions of this document are those of the authors and editors alone. Deutsche Gesellschaft für Internationale Zusammenarbeit (GIZ) GmbH does not necessarily own each component of the content and references to sources have been indicated accordingly. Any re-use of third-party-owned components such as tables, figures, and images may require permission from the copyright owner.

*We gratefully acknowledge the generous support of the four organisations who granted us permission to reproduce sections of their valuable material in this handbook, namely:*

- *Bureau of Energy Efficiency (BEE), Ministry of Power, India:  
» Guidebooks for energy managers and auditors «*
- *Department of Energy (DoE), Republic of South Africa:  
» Building energy auditing trainer's guide « and  
» Industrial energy management training course «*
- *Natural Resources Canada (NRCan):  
» Energy savings toolbox – An energy audit manual and tool «*
- *Pacific Northwest National Laboratory (PNNL), USA:  
» A guide to energy audits «*

*These publications – freely available online – are recommended to every practitioner of this subject. We have taken care to reference every citation duly. Should we be guilty of an omission in any instance, we apologise for the oversight. Our material would not have attained the standard it has without the acute practical relevance of your material to draw from.*

*Thank you, BEE.*

*Thank you, DoE.*

*Thank you, NRCan.*

*Thank you, PNNL.*

## CONTENTS

<b>1. GENERAL ASPECTS OF ENERGY MANAGEMENT .....</b>	<b>1</b>
1.1. Climate change and renewable energies .....	1
1.2. Energy efficiency definition .....	4
1.3. Energy Manager/energy management .....	9
1.4. Metrics of energy .....	13
1.5. Basics of financial and economic analysis of energy efficiency savings .....	19
1.6. Energy monitoring schedule .....	33
1.7. Software tools for energy management .....	50
<b>2. NORMS, CODES AND STANDARDS .....</b>	<b>53</b>
2.1. Introduction to energy management and auditing according to iso 50001 and iso 5000253	
2.2. The PDCA cycle .....	57
2.3. The plan/do/check/act procedure .....	62
<b>3. ENERGY EFFICIENCY IN INDUSTRIES: THERMAL PROCESSES .....</b>	<b>93</b>
3.1. Fuels and combustion .....	93
3.2. Boilers .....	94
3.3. Steam systems .....	103
3.4. Furnaces .....	105
3.5. Recuperation of heat .....	115
3.6. Heat exchangers .....	118
<b>4. ENERGY EFFICIENCY IN INDUSTRIES: ELECTRICAL APPLICATIONS .....</b>	<b>123</b>
4.1. Lighting systems .....	123
4.2. Electric motors .....	128
4.3. Compressed air systems .....	132
4.4. Ventilating, air conditioning and refrigeration systems .....	135
4.5. Fans, blowers, pumps and systems .....	139
4.6. Power generating equipment: Diesel, natural gas and solar photovoltaics .....	144
<b>5. ENERGY EFFICIENCY IN BUILDINGS .....</b>	<b>155</b>
5.1. Elements of the building energy management process .....	155
5.2. Energy consumer groups .....	159
5.3. Tariff evaluation .....	163
5.4. Energy efficiency indicators .....	164
5.5. Energy efficiency measures for buildings .....	168
5.6. Building design .....	171
5.7. Retrofitting homes and public buildings .....	175
5.8. Reference standards (local and international) .....	177



## **6. ANNEXES..... 185**

Annex 1: Keywords, summary and definitions.....	185
Annex 2: ISO 50001 chapters, overview, glossary .....	188
Annex 3: EPA portfolio manager .....	190
Annex 4: Summary of audit steps and their contents.....	192
Annex 5: Check list for a survey of buildings and offices .....	193
Annex 6: Sample contracts for contracting an auditor .....	195
Annex 7: Sample tender for energy audit .....	211



# 1. GENERAL ASPECTS OF ENERGY MANAGEMENT

## *About this module*

Energy Auditors must be well informed about the global conditions that make their work critical to the accessibility of clean, affordable electricity for industrial consumers.

## *Learning outcomes*

At the end of this module, the participant is able to

- Understand fossil fuels and their impact on climate change
- Appreciate the importance of the Energy Manager
- Differentiate the units for energy management
- Describe different energy conversion processes
- Carry out basic life cycle costing
- Plan an energy monitoring schedule

## 1.1. CLIMATE CHANGE AND RENEWABLE ENERGIES

Given the lack of emissions-related regulations in Nigeria, transportation and diesel generators are expected to be responsible for over 50% of greenhouse gas (GHG) emissions throughout the country. Light-duty vehicles – the cars, vans and light-duty trucks we drive, with majority being outside the clean drive range – are responsible for almost half of that total. While automakers have been successful in reducing criteria air contaminant (CAC) emissions from cars and light trucks, fuel usage and carbon dioxide (CO<sub>2</sub>) emissions have continued to grow steadily over the past two decades. That is because CO<sub>2</sub> – the principle GHG linked to climate change – is an unavoidable by-product of the burning of fossil fuels.

### **CLASSIFICATION OF ENERGY SOURCES**

Energy is classified in a variety of types and becomes available to humans when it flows from one place to another or is converted from one type into another. The sun supplies large flows of radiation energy on a daily basis. Part of that energy is used directly, such as daylight, ventilation or ambient heat. Another part undergoes several conversions creating water evaporation, winds, etc. Some of that energy is stored in biomass or rivers that can be harvested.

#### » ***Nigeria's intended nationally determined contribution (INDC)<sup>1</sup>***

Nigeria signed the Kyoto Protocol in 2004 and committed itself to approve the Nigeria Climate Change Policy Response and Strategy. This was done in 2012 by the Federal Executive Council and reconfirmed at COP 21 in 2015. Above that Nigeria is member of the UN Framework Convention on Climate Change (UNFCCC).

Nigeria's INDCs define national policies towards sustainable development including measures to mitigate effects of climate change. They are declared as national government priority. According to this plan the emission of carbon dioxide is to be reduced by 45% up to the year 2030 compared to "business as usual". By not undertaking these measures Nigeria

<sup>1</sup>[www4.unfccc.int/submissions/INDC/Published%20Documents/Nigeria/1/Approved%20Nigeria%27s%20INDC\\_271115.pdf](http://www4.unfccc.int/submissions/INDC/Published%20Documents/Nigeria/1/Approved%20Nigeria%27s%20INDC_271115.pdf) – accessed April 23, 2017

would suffer from exacerbated costs caused by climate change like according to a 2009 DFID study Nigeria's GDP could lose between 2-11% by 2020. This would jeopardise the achievements of development goals, especially those related to eliminating poverty and hunger and promoting environmental sustainability.

Nigeria's INDC provides an opportunity for the Federal Government of Nigeria to reduce CO<sub>2</sub> emissions mitigating climate change. It also fosters cost savings through reduced consumption of fossil fuels used for electricity and adoption of energy efficient practices by Nigerian industries. Nigeria's INDC identifies "enforced energy efficiency" as a strategy of achieving its set targets, providing possible entry points for the government to foster the adoption of energy efficiency in Nigeria.

#### » **Primary and secondary energy**

Primary energy sources are embodied in natural resources (e.g. coal, crude oil, natural gas, uranium, and renewable sources). The International Energy Agency (IEA) utilises the physical energy content method for classification, according to which primary energy is defined as energy that has not undergone any anthropogenic conversion. Primary energy is transformed into **secondary energy** by cleaning (natural gas), refinement (crude oil to oil products) or by conversion (into mechanical power, electricity or heat). When secondary energy is delivered at the end-use facilities it is called final energy (e.g. electricity at the wall outlet) that becomes usable energy in supplying services (e.g. light).

**Table 1.1: Overview of fossil fuel resources in Nigeria, 2012** – Source: *The Nigerian energy sector – GIZ, 2015*

	<b>Oil</b>	<b>Gas</b>	<b>Coal (total recoverable)</b>
Reserves	37.2 billion barrels	5.2 trillion m <sup>3</sup>	209.4 (million short tonnes) (2008)
Production	2,417 thousand barrels per day	43.2 billion m <sup>3</sup> / year	N/A
Years of extraction remaining	42 years	120 years	N/A

#### » **Renewable and non-renewable energy**

Renewable energy (RE) is any form of energy from solar, geophysical or biological sources that is replenished by natural processes at a rate that equals or exceeds its rate of use. Obtained from the continuing or repetitive flows of energy occurring in the natural environment, RE includes the utilisation of low-carbon technologies, such as solar energy, hydro-power, wind, tidal and wave power, ocean thermal energy, as well as renewable fuels such as biomass.

Various types of RE can supply electricity, thermal energy and mechanical energy, as well as produce fuels that are able to satisfy multiple energy service needs. Some RE technologies can be deployed at the point of use (decentralised) in rural and urban environments, whereas others are primarily deployed within large (centralised) energy networks. Though a growing number of RE technologies are technically mature and are being deployed on a significant scale, others are in an earlier phase of technical maturity and commercial deployment, or fill specialised niche markets (see Table 1.2 for renewable energy potentials in Nigeria).

**Table 1.2: Renewable energy potentials in Nigeria** – Source: *The Nigerian energy sector – GIZ, 2015*

Renewable Energy Potentials in Nigeria		
Resource	Potential	Current utilisation and further remarks
Biomass (non-fossil organic matter)	Municipal waste	18.5 million tonnes produced in 2005 and now estimated 0.5 kg/capita/day
	Fuel wood	43.4 million tonnes/year fuel wood consumption
	Animal waste	245 assorted animals in 2001
	Agricultural residues	91.4 million tonnes/year produced
	Energy crops	28.2 million hectares of arable land; 8.5% cultivated

**UTILISATION OF RE**

Deployment of RE has been increasing rapidly in recent years. Various types of government policies, the declining cost of many RE technologies, changes in the prices of fossil fuels, an increase of energy demand and other factors have encouraged the continuing increase in the use of RE.

Despite global financial challenges, RE capacity continued to grow rapidly in 2009 compared to the cumulative installed capacity from the previous year, including wind power (32% increase, 38 gigawatts [GW] added), hydropower (3%, 31 GW added), grid-connected photovoltaics (53%, 7.5 GW added), geothermal power (4%, 0.4 GW added), and solar hot water/heating (21%, 31 thermal gigawatts [GWth] added). Biofuels accounted for 2% of global road transport fuel demand in 2008 and nearly 3% in 2009. The annual production of ethanol increased to 1.6 EJ (76 billion litres) by the end of 2009 and biodiesel to 0.6 EJ (17 billion litres). Of the approximately 300 GW of new electricity generating capacity added globally over the two-year period from 2008 to 2009, 140 GW came from RE additions. Collectively, developing countries host 53% of global RE electricity generation capacity. At the end of 2009, the use of RE in hot water/heating markets included modern biomass (270 GWth), solar (180 GWth) and geothermal (60 GWth). The use of decentralised RE (excluding traditional biomass) in meeting rural energy needs at the household or village level has also increased, including hydropower stations, various modern biomass options, PV, wind or hybrid systems that combine multiple technologies.

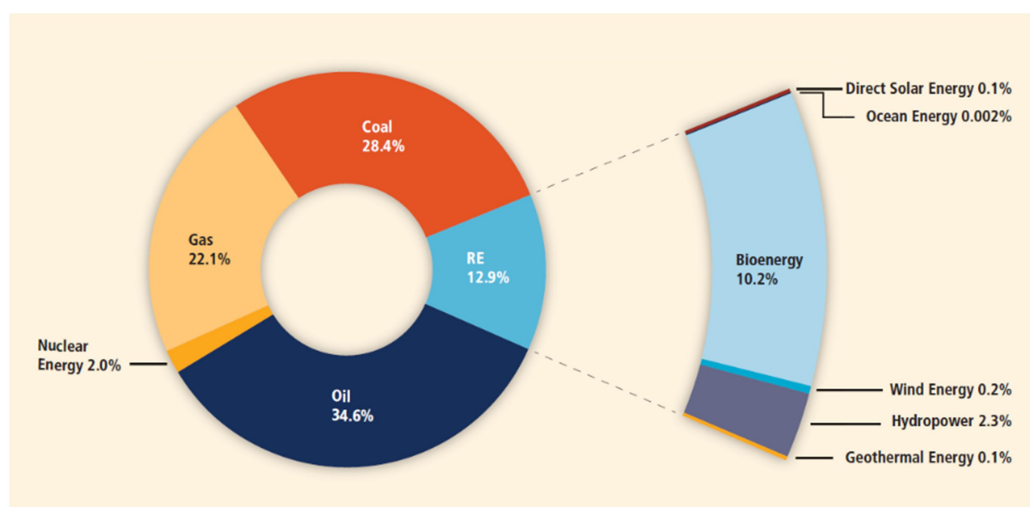

**Figure 1.1: Shares of energy sources in total global primary energy supply in 2008 (492 EJ)** – Courtesy: IPCC, *renewable energy sources and climate change mitigation, 2012*

## 1.2. ENERGY EFFICIENCY DEFINITION

This section about energy efficiency has been written while keeping practitioners as well as national and international energy efficiency experts in mind. It explains the fundamentals of energy efficiency and its practical implications on an Energy Auditor's (EA) or an Energy Manager's (EM) work and the functioning of an energy management system (EnMS).

Whoever ventures into the field of energy performance improvements is faced with various definitions of the term *energy efficiency*. Understanding this concept is highly important for the decision makers of a firm during the selection and procurement process for energy-intensive equipment as well as for Energy Auditors when calculating or testing the energy efficiency of a machine. Even the software driving EnMS equipment as well as the associated data analysis functions all fundamentally apply the equations and principals behind the concept. Therefore we will start with a brief overview of the various interpretations and financial implications of energy efficiency.

### ENERGY EFFICIENCY AND CONVERSION

Energy can be neither created nor destroyed but only converted from one form of energy to another. This conversion is performed by equipment such as boilers, electric motors, pumps, blowers, lights and diesel generators. Table 1.3 lists some examples.

Table 1.3: Energy form conversions and equipment

Energy input	Equipment	Useful energy output
Chemically bound energy in coal	Steam boiler	Steam
Electricity	Electric motor	Mechanical shaft energy
Electricity	Incandescent light bulb	Visible light
Steam	Steam turbine	Mechanical shaft energy
Low-voltage electricity	Step-up transformer	High-voltage electricity
Mechanical shaft energy	Water pump	Flow work
Chemically bound energy in diesel fuel	Diesel generator set	Electricity

Equipment responsible for the energy conversion process always produces some unused energy that is lost to the environment (but could be partially recovered) and discharged mostly in form of heat. Figure 1.2 defines the *energy conversion efficiency* or *energy efficiency* or simply *efficiency* of a machine. The mathematical equation that is used by engineers, norms and standards gives it the Greek letter eta ( $\eta$ ).

$$\eta = \frac{\text{useful energy output}}{\text{energy input}} = \frac{\text{energy input} - \text{losses}}{\text{energy input}} = 1 - \frac{\text{losses}}{\text{energy input}} < 1$$

#### » Measuring and calculating energy efficiency

#### Two methods to measure and calculate efficiency

The equation already shows that there are two methods to determine efficiency. The first method, the first part of the above equation is to measure over a given period of time all energy inputs as well as all useful energy outputs. In the case of a steam boiler running on heavy fuel oil, the measurable energy input flow would be the volume of fuel oil multiplied by its energy content. The useful energy output is the measured volume flow of live steam multiplied by its energy content leaving the boiler. But we could as well apply the equation

above in its last form and measure losses, i.e. the unused energy. Which option is the most preferable depends on the situation and the time and money invested in measuring equipment that is needed for efficiency testing in the laboratory or the field.

The second method, often called the indirect method, is usually more preferable since it allows losses to be identified and quantified. The lower the energy loss of a machine or a process, the less input energy is needed to manufacture a product or deliver a service. Some examples: Manufacturing 1 tonne of steel, processing and packing 1 litre of milk, producing 1 square metre of plywood, producing 1 tonne of cement, or 1 bicycle, or 1 light bulb, or pumping 1 m<sup>3</sup> of water to a height of 8 metres, or transporting 1 tonne of sand by truck over 10 km.

**ENERGY EFFICIENCIES AND CORRESPONDING TECHNICAL LOSSES**

**Table 1.4: Exemplary efficiencies of various energy conversion technologies**

<i>Technology</i>	<i>% Efficiency</i>	<i>% Losses</i>
Step-up transformer of a power plant	98	2
Condensing gas-fired hot water boiler	96	4
Electric motor	92	8
Non-condensing oil-fired boiler	87	13
Combined heat and power plant	80	20
Pumped storage hydro power plant	72	28
Combined cycle gas turbine (CCGT)	60	40
Supercritical coal-fired power plant, 1,000 MW block	44	56
Larger heavy fuel oil generator set	40	60
Open cycle gas turbine (OCGT)	34	66
High-efficiency photovoltaic cell	28	72
Biomass power plant	26	74
LED light	16	84
Small 2–5 kW gasoline captive power backup	13	87
Human beings	12	88
Incandescent light bulb	4	96

Physicians and medical researchers have of course discovered that the human being is also a combustion system, albeit a rather complex one that combusts expensive energy in the form of food and generates mostly mechanical energy at a relatively low efficiency of about 12%. Compared to all the other machines humankind has designed in the last 100 years, we are at the bottom of the list.



**Figure 1.2: Energy conversion efficiency principle**



## ENERGY SAVINGS

Energy savings have been attracting financial incentives in quite a number of countries. The initiatives are mostly managed by energy utilities and take the form of rebates for buying energy-efficient white goods or lighting to reduce monthly electricity bills or for investing in other energy management opportunities (EMOs) to reduce natural gas and electricity consumption. In the context of this handbook these important definitions below are applied.

- a) **“Energy efficiency savings”** means the saving of energy by increasing the energy efficiency of a technology or process either by retrofitting or by procuring more efficient equipment.

*Example 1:* Incandescent light bulbs are replaced by efficient LED lighting for an energy efficiency savings of 75%.

*Example 2:* An open cycle gas turbine (OCGT) is converted to a combined cycle gas turbine (CCGT). The measure will increase the design energy efficiency from 32% to 50%, resulting on paper in an energy efficiency savings in the form of natural gas of  $(50-32)/50 = 36\%$ .

- b) **“Energy conservation”** means the saving of energy **without** increasing the energy efficiency of a technology or a process.

*Example 3:* Turning off office lights at night when not needed is a typical energy conservation measure that does not improve the energy efficiency of a lighting system.

*Example 4:* Increasing the temperature of an air conditioned room from 22°C to 24°C will reduce the electricity consumption of the air conditioner but not improve the design energy efficiency of an air conditioner.

- c) **“Energy savings”** means the saving of energy through energy efficiency savings, or energy conservation, or both.

*Example 5:* Turning off incandescent lights at night when not needed is an energy saving measure because it conserves energy. Replacing incandescent light bulbs by LEDs is also an energy savings measure because it improves the energy efficiency of the lighting systems and therefore generates energy efficiency savings. Replacing incandescent light bulbs by LEDs and turning the LEDs off at night when not needed is an energy saving measure as well because it improves the energy efficiency of the lighting system **and** on top of that conserves energy.

Differentiating between energy efficiency savings and energy conservation is not just a semantic gimmick when it comes to national fiscal and financial incentives programmes managing budgets of hundreds of millions of USD. The question that portfolio managers should ask themselves is whether energy conservation measures with extremely short pay-back periods should be incentivised or whether it would be better to impose a direct or an indirect penalty for not implementing highly cost-effective energy conservation measures.

**Note:** It must also be remembered that all EMOs that might lead to energy savings must be technically viable and financially attractive. Recommended EMOs must fall within the financial capacity of the client.

» **SANS 50010 definition of energy efficiency savings**

SANS 50010 is the energy savings monitoring and verification standard of the Republic of South Africa. The standard is of particular interest since under the 12-L regulation the “kWh saved” procurement program of Treasury and the South African Revenue Service (SARS); an energy performance baseline must be prepared according to the provisions of the standard. Moreover, eligible “kWh saved” must be quantified based on the provisions of the standard before they can become eligible as a tax reduction. The legally binding definition of energy efficiency savings of SANS 50010 is provided below.

- i. **Definition of energy efficiency savings:** “Difference between the actual amount of energy in the carrying out of any activity or trade in specific period of time and the amount of energy that would have been used in carrying out of the same activity or trade during the same period under the same conditions if the energy saving measure was not implemented”.
- ii. **Definition of an activity:** “An action, process or operation of machinery or equipment that results in the consumption of energy”.

Both definitions and the past 4-year experience with 12-L regulation implementation showed some difficulties related to the interpretation of energy efficiency savings and eligibility of energy conservation measures under 12-L as well as the technical challenges and cost effectiveness of baseline preparations and quantification of energy saved beyond deemed energy savings estimates.

» **Calculating energy efficiency savings**

One major objective of an energy audit (EA) is to find ways to reduce costly energy losses or in other words increase the efficiency of a process or a machine by either retrofitting the technology, or changing the way it is operated, or replacing it by a more efficient and newer design that can perform the same job and provide the same service level as the old one under the same conditions. Energy Auditors have an astoundingly simple way to calculate energy savings based on the energy efficiency concept. This is easily achieved by applying the simple equation below:

$$S = 100 \times \frac{\eta_2 - \eta_1}{\eta_1}$$

**Example 6:** An incandescent light bulb is replaced with an LED light with the same lumens per watt of useful energy output. The LED has an efficiency of 16% while the light bulb has only 4%. Consequently, the electricity savings are  $S = 100 \times (16 - 4) / 4 = 75\%$  for the same level of lighting services.

**Example 7:** Instead of buying an electric motor with an advertised 83% design efficiency at nominal load management, an electric motor with 87% efficiency is purchased. The electricity cost savings on paper are  $S = (87 - 83) / 83 = 4.6\%$ .

**Energy units:** The most common energy units are kWh, kCal, MJ, and BTU. You can find a convenient energy unit convertor online at [www.iea.org/statistics/resources/unitconverter/](http://www.iea.org/statistics/resources/unitconverter/)

**Note:** In countries following the SI system, the energy unit kWh is not only used for electricity but also for fuel and steam energy. Consequently 1 litre of gasoline contains about 9 kWh of energy.

» *Incentives for energy efficiency*

Currently, apart from savings on energy costs, there are no incentives to support the adoption and implementation of energy management activities in Nigeria. Industry and businesses, who attempt to do so, do so solely because they see the benefits accruing from cost reductions and savings which can be realised. In 2016, the National Renewable Energy and Energy Efficiency Policy (NREEEP) was approved by the government. The NREEEP realises and recommends that incentives are required for the seamless adoption of energy efficiency in Nigeria; it however does not make any suggestions on examples of incentives except broadly recommending tax breaks.

Notwithstanding Nigeria's slow progress to the adoption of energy efficiency practices, a good number of countries have been successful in achieving nationwide adoption catalysed by incentives. Table 1.5 shows examples of incentives which were successful in ensuring adoption of energy efficiency concepts in selected countries. Examples from which Nigeria could make adaptations to suit local conditions.

**Table 1.5: Energy efficiency incentives in select countries**

Country	Incentives
USA <sup>1</sup>	<p>Tax deduction of the cost of energy-efficient assets installed in commercial buildings: A tax deduction of up to USD 1.80 per square foot for buildings that save at least 50% of the heating and cooling energy of a system or building that meets ASHRAE Standard 90.1-2001 (if placed in service before January 1, 2016) or 90.1-2007 (if placed in service before January 1, 2017). Partial deductions of up to USD 0.60 per square foot can be taken for measures affecting the building envelope, lighting, or heating and cooling systems.</p> <p>Accelerated depreciation for smart meters and smart grid systems: Currently, taxpayers generally recover the cost of smart meters and smart electric grid equipment over a 20-year period. The Energy Policy Act of 2005 (EPACT) allows taxpayers to recover the cost over a 10-year period.</p>
Singapore <sup>2</sup>	<p>A one-year accelerated depreciation allowance for EE equipment tax incentive encourages companies to replace old, energy-consuming equipment with more energy efficient ones and to invest in energy-saving equipment. Under this scheme capital expenditure on qualifying energy efficient or energy-saving equipment can be written off or depreciated in one year instead of three.</p>
Netherlands <sup>3</sup>	<p>The Accelerated Depreciation of Environmental Investments Measure (VAMIL) provides accelerated depreciation and deductions on qualifying energy-efficient assets. Depreciation of up to 75% of the investment costs is available and the maximum investment cost is EUR 25 million. An additional deduction of 41.5% of investment costs in energy-efficient and renewable-energy equipment is also permitted.</p>
China <sup>2</sup>	<p>Companies can apply for a tax deduction of 10% of the amount invested in EE equipment, and if the deduction is not utilised, it can be carried forward for five years. There are also waivers on custom duties and VAT for certain imported EE equipment.</p> <p>Certified ESCOs that are contracted to eligible energy performance contracting projects are allowed a corporate tax exemption in the first three years and an effective rate of 12.5% over the following three years. Moreover, ESCOs can claim exemption from VAT on the transfer of assets to clients at the end of a project and assets can be transferred as if fully depreciated for corporate income tax purposes.</p>
Japan <sup>3</sup>	<p>The central government supports for energy-efficiency retrofit projects directly. A subsidy</p>

<sup>1</sup> <https://energy.gov/eere/buildings/tax-incentives-energy-efficiency-upgrades-commercial-buildings> – accessed April 23, 2017

<sup>2</sup> [www.nea.gov.sg/grants-awards/energy-efficiency/one-year-accelerated-depreciation-allowance-for-energy-efficient-equipment-and-technology-\(adas\)](http://www.nea.gov.sg/grants-awards/energy-efficiency/one-year-accelerated-depreciation-allowance-for-energy-efficient-equipment-and-technology-(adas)) – accessed April 23, 2017

<sup>3</sup> [www.iisd.org/sites/default/files/publications/10\\_big\\_ideas\\_making\\_energy\\_bankable\\_india.pdf](http://www.iisd.org/sites/default/files/publications/10_big_ideas_making_energy_bankable_india.pdf) – accessed April 23, 2017

Country	Incentives
	<p>seeks to increase credibility and recognition of the energy-efficiency Interventions. The implemented schemes are listed below in volume and percentage subsidised):</p> <ul style="list-style-type: none"> <li>▪ Introducing equipment with lower energy consumption (up to USD 126 million – 33%)</li> <li>▪ Highly energy-efficient systems in residential buildings (up to USD 19 million – 33%)</li> <li>▪ Local authorities’ energy-saving diffusion-and-promotion projects (up to USD 33 million – 50%)</li> <li>▪ Energy management systems for building (up to USD 33 million – 50%)</li> <li>▪ Local authorities’ energy saving planning (up to USD 5 million – 100%)</li> </ul>

### 1.3. ENERGY MANAGER/ENERGY MANAGEMENT

The Energy Manager is usually a person that is employed by a firm and he/she has been trained and maybe even certified in relevant aspects of energy management.

#### ENERGY MANAGEMENT SYSTEM

In light of global energy prices that are increasingly volatile in an overall upward trend and environmental priorities such as climate change and greenhouse gas emissions reduction, managing energy has become a critical priority in today’s industrial sector environment. Nigeria, Africa’s largest economy, has the second highest emissions rate on the continent after South Africa, mainly because of gas flaring. Nigeria was ranked fifth globally amongst countries with the highest amount of gas flared in 2015 (EIA, 2015).

Improving the energy efficiency of industrial organisations offers many cost reduction opportunities. Like people, money, and merchandise, energy is part of the management resources of an organisation, and needs to be systematically managed and controlled in harmony with the organisation’s management of other resources. Energy management – the process of understanding and managing energy costs through energy efficiency and energy purchasing strategies – is a management issue.

As a management issue, the achievement of energy efficiency and the financially attractive cost savings that often come with it involves many organisational facets. Clearly, there are technical issues because energy is consumed by technical systems. But people operate technical systems, and people can dramatically influence energy consumption levels. A strong commitment on the part of the organisation is also necessary to ensure the success of any business undertaking – energy efficiency included. With energy playing a fundamental role in achieving the goals of sustainable development in Nigeria, strategic planning and the management of energy resources deserve a high priority in the country and in the development plans of any organisation.

Organisations that successfully manage their energy use typically share several characteristics that can serve as a guide:

- Broad awareness of the benefits of energy efficiency throughout the organisation;
- Data collection and analysis for energy use management;
- Existence of an energy management plan – both for the short and long term;
- Integration of the task of energy management into the overall management structure of the organisation;
- Leadership for energy management through a “champion” or group of committed staff – an energy management team;

- Top-down commitment expressed in the form of an energy efficiency policy.

The term “energy management” means many different things to different people. As a general rule, it involves the application of at least three principles:

1. Purchasing the energy supply mix at the lowest possible price per unit of useful energy output;
2. Energy conversion management and peak efficiency consumption;
3. Utilisation of most appropriate technology.

It is a useful exercise to take a few minutes to develop a list of the actions or measures associated with each of these principles in your organisation.

In considering principle 1, energy purchasing, the building operator needs to assess the price, availability, and energy content (in fact, the cost per unit of energy available from the source), as well as those issues that influence his or her ability to negotiate favourable energy purchase agreements.

Consideration of principle 2 should allow the operator to generate a list of management actions that he/she or someone else in the organisation can take now to ensure that energy is used as efficiently as possible.

Principle 3 may be the most difficult one to deal with in the short term for any industry. However, in thinking about the technological aspects of energy use, it is helpful to categorise measures as:

- No cost – that is, housekeeping and operational changes
- Low cost – that is, measures that may require some investment in technology, but that rely extensively on input from people and therefore may include training of staff and energy groups and (re-)consideration of the purchasing policy
- High cost – those measures that require significant investments of capital for the acquisition and installation of new technology.

#### » *Dimensions of energy management systems*

The experience of organisations that successfully manage their energy use indicates that technological solutions alone do not achieve maximum energy savings, and are less likely to be sustained in the long term. Rather, energy management has the greatest impact when organisations address these three dimensions:

- **Technical:** Energy-consuming devices and systems that use or convert energy efficiently (or inefficiently).
- **Organisational:** Structures and management systems that can support or hinder the achievement of energy efficiency goals.
- **Behavioural:** Personal values, attitudes and practices of individuals in the organisation that impact on energy use.

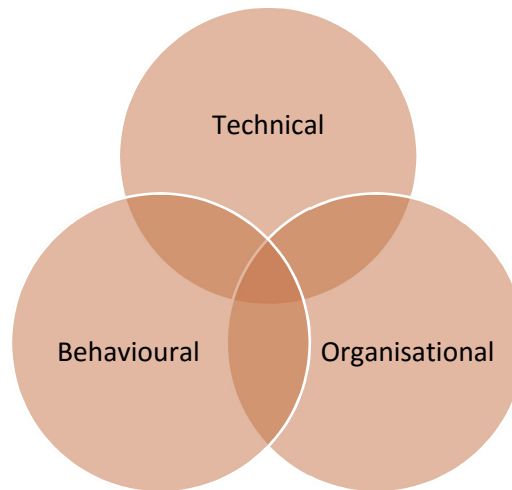

**Figure 1.3: Dimensions of energy management**

What role does behavioural action have to play with all the automated technologies at our disposal? Energy inefficiency and waste is largely invisible and difficult to quantify – an issue which makes it very difficult to manage. Many people, to varying extents, are unaware of just how wasteful they are with various forms of energy in their daily behaviour and what this wasteful behaviour ultimately costs. There are cases to demonstrate that a focus on people alone – their awareness of energy efficiency as a corporate priority, their values and attitudes towards energy use, and their skills and knowledge related to the management and use of energy systems – can achieve significant and sustainable savings. The combination of these two approaches – technological and human resources – typically yields the best result.

It follows that the success of energy management will be maximised when the “human factor” – employee behaviour and organisational practices – are taken into account, rather than focusing exclusively on technological changes; one tool to reach this objective is the energy audit.

» ***The energy audit***

An energy audit can be instrumental in assessing the potential for energy savings and identifying the specific measures that can give rise to improved efficiency. It is interesting to note that the term “energy audit” does not refer explicitly to a list of energy saving measures. Rather, it asserts that gaining an understanding of how a facility uses energy will inevitably lead to the identification of measures that reduce energy consumption. What follows from this assumption is that the audit procedures must reveal the energy consumption characteristics of the particular plant or system in question.

Energy audits identify energy saving opportunities. Audits performed by Energy Auditors have traditionally focused on capital improvements or technological energy saving opportunities. However, good energy audits also have the potential to identify many more operational, or less capital-intensive, opportunities; this is a theme that is embodied in the methods developed in this course. It draws on knowledge of topics such as project appraisal, cost structuring, profitability and environmental responsibility.

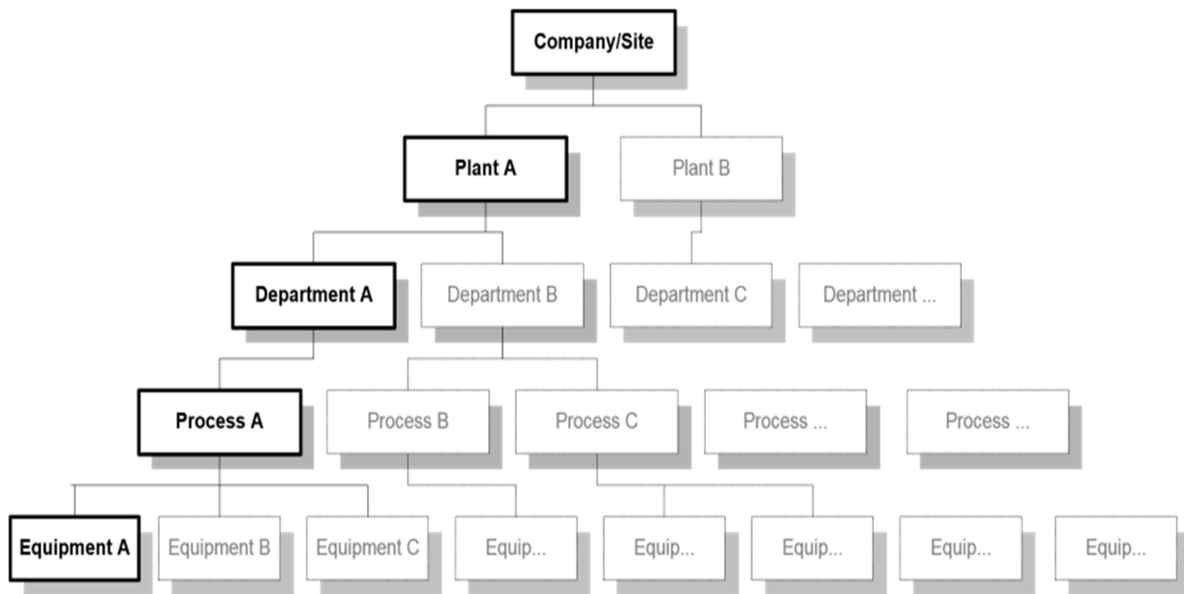

» **Organisational structure of an energy-consuming system**

**Figure 1.4: Structure of an energy-consuming system** – Courtesy: *Energy savings toolbox – An energy audit manual and tool* - Natural Resources Canada, 2011. Reproduced with the permission of the Department of Natural Resources, 2016

An energy-consuming system is a collection of elements that consume energy. Energy audits are usually concerned with systems that may be as extensive as a multi-plant or multi-process industrial site, or as narrow as a single piece of equipment such as a boiler.

Figure 1.4 illustrates the generic structure of an energy-consuming system as it may exist on an industrial site. For simplicity, the figure above only shows one branch for each subordinate level in the system hierarchy. Real systems would have many branches from each component to various lower levels. In this manual, the term “energy-consuming system” may refer to a site, building, department, system or piece of equipment, or any combination of these.

» **Energy balance**

The first law of Thermodynamics states: “Energy can neither be created nor destroyed”. Whatever we or our man-made machines do involves the conversion of one form of energy input into at least two other forms of energy output. One form is the output of useful energy. The balance is energy loss. Our sole objective in this context is to change the system in such a way that we reduce the technical losses cost-effectively.

Energy management comes with two basic challenges:

- How to specifically define the system being considered;
- How to quantify energy flows into and out of that system.

The first of these challenges involves defining a **system boundary**. As noted above, by “system”, we mean any energy-consuming building, area within a building, operating system, collection of equipment, or individual piece of equipment – around which we can, figuratively, place a boundary. On a schematic diagram, as in the following Figure 1.5, a pencil line encircling our “system” serves as the boundary.



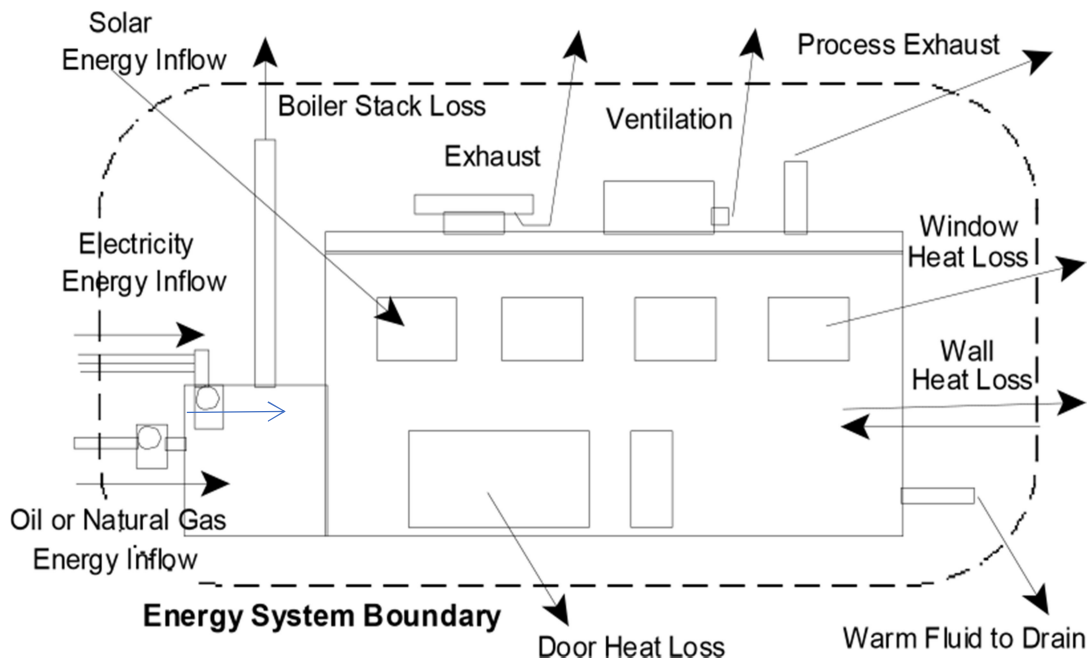

Figure 1.5: Facility energy system

What happens *within* the system boundary is of little concern from an energy accounting standpoint. The energy streams that *cross the boundary* must be accounted for. **It is therefore essential that the system boundary be defined in very specific terms.**

The second of these challenges is the more difficult in technical terms, as it involves the collection of energy flow data from various sources, including direct measurements. The estimation of energy flows that cannot be directly measured, such as heat loss through a building wall, or in vented air, is likely also to be involved. Remembering that we only need to concern ourselves with the energy flows that cross the system boundary as we have defined it, the following points must be considered when quantifying energy flows:

- Select convenient units of measure, and be able to convert the various units to one selected unit for the consolidation of data (e.g. express everything in equivalent kWh or MJ of energy);
- Know how to calculate the energy contained in material volume and mass flows – as in hot water to drain, cooled air to vent, intrinsic energy in processed materials, etc.;
- Know how to calculate heat from the various precursor energy forms, as in electricity converted to heat through the operation of an electric motor.

## 1.4. METRICS OF ENERGY

### PHYSICAL UNITS AND CONVERSION

#### » Definitions

Energy is very simply defined as *the ability to do work*. In technical terms, work is defined as **force (F) applied through displacement (d)** (the vector equivalent of distance):

$$W = F \cdot d$$

» **Forms of energy**

Energy can take many different forms and do many different types of work. As stated above, one very important law of nature which guides the process of energy management is that energy cannot be created or destroyed, but only converted from one form to another. The forms of energy discussed in this manual include chemical energy, thermal energy, mechanical energy, and electrical energy. Table 1.6 below shows these and other energy forms and their natural sources.

**Table 1.6: Energy forms and natural sources**

<b>Type of energy</b>	<b>Sources</b>
Potential energy	Hydro
Kinetic energy	Wind, tidal, hydro
Thermal energy	Geothermal, ocean thermal
Radiant energy	Solar
Chemical energy	Oil, coal, gas, biomass
Electrical energy	Lightning

**CHEMICAL ENERGY**

Chemical energy is the energy that helps to “glue” atoms together in those clusters called *molecules*, or *chemical compounds*. Of special interest to us are fuels or their derivatives such as natural gas, liquefied petroleum gas (LPG), coal and oil that can be combusted. When these fuels burn, they undergo a chemical change that results in a separation and reconfiguration of the atoms in the molecules into products of combustion. In this process, the chemically bound energy that held the atoms together is liberated in a different form, as high-temperature heat or thermal energy, a form well suited to doing many different kinds of work.

**THERMAL ENERGY**

Thermal energy involves the microscopic movement of atoms and molecules in everything around us. Thermal energy is often commonly referred to as heat. In everyday language, heat is both a noun and a verb. Heat flows; we heat. In fact, we consider two basic types of heat:

- **Sensible heat** is energy that changes the temperature of a body or a substance – we can sense it.
- **Latent heat** is energy that initiates a phase change; the temperature of a substance is not changed.

To illustrate these two forms, the process of producing steam involves both sensible and latent heat: as the water is raised from its initial temperature to the boiling point, 100°C at 1 atmosphere pressure, sensible heat is required. At the boiling point, additional heat is required to convert the water from liquid to vapour; that heat is latent heat and it is a property of the respective substance, in this case water, and the conditions at which the change of state occurs.

Thermal energy may move in many different ways, between many different substances, and change back and forth between its sensible and latent forms. However, it flows spontaneously only from a higher temperature area to a lower temperature area.

### Thermal energy units of measure

Thermal and electrical energy units can be inter-converted. The basic unit of thermal energy is the joule (J) defined as the work done (or mechanical energy required) when a force of 1 Newton is applied over a distance of 1 metre. Because the joule is relatively small, we usually speak of megajoules (MJ = 10<sup>6</sup> joules) or gigajoules (GJ = 10<sup>9</sup> joules).

The delivery of 1 J/s is equivalent to 1 watt. It follows that 1 kWh = 3.6 MJ. For further energy conversions, you may use the unit converter of the International Energy Agency. [www.iea.org/statistics/resources/unitconverter/](http://www.iea.org/statistics/resources/unitconverter/)

### Heat capacity

In many everyday situations, thermal energy is transported from one place to another by simply heating a substance, and then moving that substance. A good example is a hot water heating system for the generation of hot process water. Heat is moved from the boiler to the process equipment by heating water at the boiler and then pumping it to the process system where it delivers the required heat. Water is frequently used because it has a good capacity to retain heat.

The *specific (i.e. per unit mass) heat capacity* of a substance is defined as the amount of heat required to raise the temperature of 1 kilogram of the substance by 1°C. The unit of measure is kilojoule per kilogram Celsius. Typical specific heats are listed below.

Table 1.7: Specific heat capacity of some substances

Substance	Specific heat capacity
Water	4.19 kJ/(kg °C)
Hydrogen (15 °C)	20.4 kJ/(kg °C) (constant volume)
Ice	2.04 kJ/(kg °C)
Aluminium	0.912 kJ/(kg °C)
Brick	0.8 kJ/(kg °C)

Usually the heat capacity of a substance is a known variable and the question is how much heat is required to raise its temperature by a certain amount or how much heat it contains. A very simple formula can be used to calculate the answer.

$$Q = m \cdot c \cdot (T_2 - T_1)$$

Where, Q = Heat [kJ]  
 m = Mass in [kg]  
 c = Specific heat capacity [ $\frac{kJ}{kg \cdot ^\circ C}$ ]  
 (T<sub>2</sub>-T<sub>1</sub>) = Temperature change [°C]

This is a very useful formula in energy management. Thermal energy is often transferred via the flow of water, air, or other fluids. This formula, or one based on it, may be used to calculate the energy flow that is associated with this mass flow.

**Example 8:** A cooling system for electric drives uses 1,000 L water per hour; the input temperature is 15°C, the output is 55°C, and the electric drives operate for 6,000 hours per year. How much heat is captured in the water? Is that heat sufficient to heat a production process that requires heat at a minimum temperature 45°C with an annual quantity of 40 kWh.

$$Q_{cooling} = 1,000 \frac{kg}{h} \cdot 4.19 \frac{kJ}{kg \cdot ^\circ C} \cdot (55^\circ C - 15^\circ C) \cdot 6,000h = 280 kWh$$

$$Q_{heating} = 1,000 \frac{kg}{h} \cdot 4.19 \frac{kJ}{kg \cdot ^\circ C} \cdot (55^\circ C - 45^\circ C) \cdot 6,000h = 69 kWh$$

The available energy amount is sufficient. A further calculation of a technical solution that considers among others energy losses, operation times, investment and costs needs to be made.

### MECHANICAL ENERGY

Mechanical energy is the energy of physical movement or position. When stored as energy of movement, it is called **kinetic energy**, defined as:

$$KE = \frac{1}{2} \cdot m \cdot v^2$$

Where m is the mass of the moving object or substance and v is its velocity. When stored as energy of position, it is called potential energy, defined as:

$$PE = m \cdot g \cdot h$$

Where m again is the mass of the object or substance, g is the acceleration due to gravity (9.8 m/s<sup>2</sup> at sea level) and h is the height of the object or substance above a reference point.

### ELECTRICAL ENERGY

Electrical energy involves the movement of electric current through wires. Electrical energy is a very useful form of energy because it can perform many functions. Ultimately, most electrical energy or electricity also ends up as thermal energy in the form of sensible heat. Some devices such as electric heaters convert the energy directly; other devices such as motors convert electricity to mechanical energy, which eventually becomes heat. The trick to optimising electricity use is to maximise the amount of work done by electricity before it is lost as heat. Typically, this also involves optimising the use of mechanical energy.

#### » Units of energy

The basic unit of energy in the metric system is the joule. Energy in the form of electricity is given in units of watt-hours. The prefix “kilo” indicates 1,000 units. Common equivalencies between units are shown in Table 1.8. On an international level and depending on the described energy form and amount of energy, several different units for energy are used. An overview is given in Table 1.9.

Table 1.8: Units of energy

Energy equivalents	
1,000 joules (J)	1 kilojoule (kJ)
1 kilowatt-hour (kWh)	3,600,000 J or 3.6 MJ

Table 1.9: General factors for energy

To:	TJ (Tera joule)	Gcal (Gigacalorie)	Mtoe (Megatonnes of oil equivalent)	MBtu (Mega British thermal unit)	GWh (Gigawatt hours)
<b>From (multiply by):</b>					
TJ	1	238.8	$2.388 \times 10^{-5}$	947.8	0.2778
Gcal	$4.1868 \times 10^{-3}$	1	$10^{-7}$	3.968	$1.163 \times 10^{-3}$
Mtoe	$4.1868 \times 10^4$	107	1	$3.968 \times 10^7$	11,630
MBtu	$1.0551 \times 10^{-3}$	0.252	$2.52 \times 10^{-8}$	1	$2.391 \times 10^{-4}$
GWh	3.6	860	$8.6 \times 10^{-5}$	3.412	1

Source: IPCC for further calculations<sup>1</sup>

### » Difference between energy and power

**Power** is the rate of energy flow, or **how fast** energy is being used or transferred.

Power is measured in joules per second (J/s). One joule per second is equivalent to one watt. Mechanical power is usually measured in kilowatts in the metric system and horsepower in the Imperial system.

Table 1.10: Units of power

<b>Power (energy rate) equivalents</b>	
1 kilowatt (kW)	1 kilojoule/second (kJ/s)
1 horsepower (HP)	746 watts (0.746 kW)

The electrical power or demand in a circuit depends on two fundamental quantities, *voltage* and *current*:

- *Voltage (U)* is the magnitude of the driving force that sends electrical charge through a conductor (similar to pressure in a water distribution system or the force applied by a person pushing a child on a swing). Voltage is measured in volts.
- *Current (I)* is the rate of flow of charge through a wire caused by the push of the voltage (similar to the rate of flow of water through a pipe or the speed of the child being pushed on a swing). Current is measured in amperes (amps).
- *Power (P)* is voltage and current acting together to do useful work. Power is measured in watts. Mathematically, the relationship is represented as:

$$P = U \cdot I$$

- *Demand* is the rate of use of electrical energy. The term “demand” means essentially the same as electrical power, although demand generally refers to the average power measured over a given time interval. *Peak demand* is the maximum demand experienced over a given time interval, and is especially important to how we purchase electricity.

<sup>1</sup> International Energy Agency. [www.iea.org/statistics/resources/unitconverter/](http://www.iea.org/statistics/resources/unitconverter/) – accessed: March 17, 2017

### » Demand and electrical energy

In the previous section, we talked about electric power or demand. When power is consumed for a period, energy is used. Energy consumption is the total amount of electricity consumed over time and is measured in **kilowatt hours (kWh)**. By definition:

$$E = P \cdot t$$

Whereas E is energy with its unit kWh, P the demand, most in kW (kilowatts) and t is the time in hours.

### » Energy conversion processes

Energy conversion is the process of changing energy from one form to another normally with the aim of converting that energy into a useful form. The crux is that any energy conversion will generate usable and non-usable energy. We refer to the latter as technical losses.

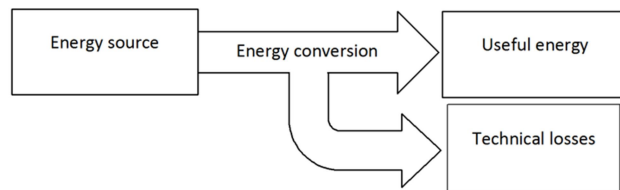

Figure 1.6: Energy conversion process

Historically, human-driven energy conversion processes have included:

- Biomass → heat (for cooking and heating)
- Solar → heat (for drying clothes or food)

Solar is still the main natural light source, which can be used without the need for conversion. Solar is the energy source for biomass, wind and hydropower.

- Biomass → farm animals → horsepower, food

Later, humans also invented and systematised these conversions:

- Coal → heat
- Hydro → milling flour, running machinery
- Wind → pump water

During the period of industrialisation, energy conversion processes shifted to rely more and more on fossil fuels and become the main driver of rapid technological developments. Additional energy conversion processes in modern times include:

Heating of buildings

- Gas, oil, biomass → heat
- Solar → heat

Electricity generation

- Coal, gas → heat → mechanical → electricity
- Hydro → mechanical → electricity
- Wind → mechanical → electricity
- Solar → electricity

## Transportation

- Oil → gasoline, diesel, jet fuel → heat → mechanical
- Biomass → ethanol → heat → mechanical
- Fuel cell cars: gas → hydrogen → electricity → mechanical
- Hybrid cars: gasoline → mechanical → electricity → battery → electricity → mechanical

### 1.5. BASICS OF FINANCIAL AND ECONOMIC ANALYSIS OF ENERGY EFFICIENCY SAVINGS

This section provides a toolkit of methodologies for the financial and economic analysis of energy efficiency saving measures. The emphasis lies on “energy efficiency savings” measures, meaning an investment in energy management opportunities (EMOs) that reduce technical energy losses, i.e. increase energy efficiency as defined the equations above.

Energy conservation measures such as turning off inefficient lights when not needed do not require investments in more efficient technologies and are considered low-cost investments primarily aimed at changing the attitude of management and staff. For instance, instead of just turning off inefficient lighting, an Energy Manager might decide to replace the inefficient lighting with an efficient alternative and turn off the efficient lighting when not needed.

Both the EM and EA should be familiar with financial and economic appraisals of EMOs for different reasons. The EA must be familiar with financial appraisals of EMOs with or without government incentives. The EM needs the know how to defend the financial attractiveness of EMOs before management because each EMO will compete with other, potentially more attractive projects for the firm’s equity. Fortunately, many EMOs are low-cost measures with a pay-back period of less than 2 years. But other EMOs such as a combined heat and power (CHP) system, a new furnace, or a chiller will be capital intensive, have much longer amortisation periods and require more sophisticated financial appraisal methodologies.

Financial and economic analysis is more of an art than a science for EMOs with an operational lifetime of more than 15 years, while EMOs with short pay-back periods do not require a sophisticated appraisal. In the latter case, a more relaxed approach to financial appraisal will serve just as well. Companies employ the following financial appraisal methodologies:

- a. **Benefit/cost analysis:** An EMO generates quantifiable benefits as well as costs. Adding up all financial benefits and dividing them by all the costs accruing throughout the operational life of the EMO should therefore be a number larger than 1 to be financially attractive to the company. If not, the benefits are smaller than the cost and the EMO is certainly *not* attractive for a company and should not be implemented. A B/C ratio of 10 means that the benefits represent a tenfold increase over costs and the EMO would therefore seem to be a very good deal. We will deal with the nitty-gritty of specifying the benefits as well as the costs in later sections.
- b. **Pay-back period:** Most EMOs require an initial capital investment and may incur additional costs throughout their operational life. Simply speaking, the static (SPP) or dynamic (DPP) pay-back period of an EMO is the length of time needed to recover all its costs. Cost recovery is achieved through energy cost savings and any other cost savings or incentives the EMO may trigger. All investors understand the notion of



pay-back period. Most companies set a maximum pay-back period for EMO investments that are operational cost-cutting measures as a matter of company policy.

- c. **Generation cost of energy saved:** Energy consumers have the choice to either avoid the consumption of 1 kWh of energy or to procure 1 kWh of energy. Obviously it would be a good deal for an energy consumer if an investment in an EMO saves 1 kWh of electricity at costs of 2 cents/kWh instead of paying the utility 8 cents/kWh for the supply of 1 kWh. In other words, 1 “kWh saved” results in electricity cost savings of  $8 - 2 = 6$  cents. How to calculate the costs of “kWh saved” will be explained in greater detail later in this handbook.
- d. **Net present value (NPV) of an EMO:** The NPV of an EMO is defined as the increase in wealth of a company or any other party implementing and financing an EMO. An EMO resulting in a negative NPV is not a good project idea since it decreases the wealth of the investor instead of increasing it. The NPV value is not just a single number but a curve that shows how the investor(s) recover the investment over the useful life of the EMO. The SPP or DPP are closely linked to the shape of the NPV curve and represent the points in time the NPC curve intersects the x-axis.
- e. **Internal rate of return (IRR):** The internal rate of return for a project is the interest earned on the outstanding balance of the total project investment. Note that the IRR is not the interest earned on the total investment. The project IRR is a by-product of the NPV calculation and defined as the discount rate at which  $NPV = 0$ . There may be more than one point in time with  $NPV = 0$  in the operational life cycle of an EMO. A typical example is fuel-switching EMOs. As a general rule, the EA or EM should always prepare the NPV curve and not only calculate the IRR of the project life cycle.
- f. **Least life cycle cost (LLCC):** There are still too many companies that do not select and procure energy-intensive equipment based on least life cycle cost considerations. How to perform an LLCC assessment and how to tender large energy-intensive equipment and appraise the offers based on least life cycle cost is part of any standard EM training and will be discussed in later in this handbook. Four more subjects related to the financial and economic appraisals of EMOs will be discussed in this chapter as well:
  - a. Distinction between economic and financial analysis of an EMO investment;
  - b. Basic principles of repaying a loan;
  - c. “Energy cost/depreciation cost” ratio and its importance to identify attractive EMOs;
  - d. Reversible versus irreversible investment errors of energy-intensive equipment.

### **ECONOMIC EVALUATION**

The focus of this section is the financial and economic analysis of energy saving measures. The financial analysis of an EMO compares the benefits and costs to the firm, while the economic analysis compares the benefits and cost to the whole economy. Energy saving measures encompasses energy efficiency savings as well as energy conservation measures as defined in section 1.5. For convenience, the abbreviation EMOs is used for energy saving measures although not all EMOs will result in quantifiable energy savings but may only provide a conducive environment to reduce energy costs in a technically viable and financially attractive manner.

**Example 8:** An EMO replaces inefficient lighting with efficient LED lights. This action should result in a B/C ratio larger than 1 and is therefore financially attractive for the company since the benefits outweigh the costs. How to calculate the cost/benefit analysis is explained in greater detail in the next sections.

Next, assume the electricity tariff is low, because the power utility produces electricity from highly subsidised natural gas costing only USD 3 per million BTU and the subsidy is paid by the government. Consequently, the EMO financed by the company reduces the subsidy burden of the government and is considered an economic benefit to society as a whole. In this case, the economic analysis appraises the economic benefit for the government by calculating the reduction in subsidies.

Furthermore, assume that the government recognises that national promotion of efficient lighting will reduce public subsidies. It could therefore offer fiscal or financial incentives to companies participating in an efficient lighting campaign. The national campaign costs for the government will be the subsidies paid plus administrative and promotional costs.

Consequently, the government must as well estimate its own campaign costs and calculate the economic B/C ratio to make sure the subsidies and administrative costs are not too high. The latter phenomenon is called over-subsidising. Standard methodologies for the financial and economic analysis applied to EMOs addressing electricity and natural gas savings can be found at the following websites:

1. [www.epa.gov/sites/production/files/2015-08/documents/cost-effectiveness.pdf](http://www.epa.gov/sites/production/files/2015-08/documents/cost-effectiveness.pdf)
2. [www.cpuc.ca.gov/WorkArea/DownloadAsset.aspx?id=7741](http://www.cpuc.ca.gov/WorkArea/DownloadAsset.aspx?id=7741)

» **Cost/benefit analysis**

**INTRODUCTION TO ENERGY PRODUCTION COST CALCULATION**

The literature refers to the methods for calculating energy production costs as the “levelised cost of energy” (LCOE). The LCOE interpretation is: “Sum up all monthly or yearly discounted *costs* for engineering, procurement, construction and the operation of a power plant throughout its operational life and divide that number by the sum of monthly or yearly discounted energy *outputs* throughout the operational life. The discount rate *d* is usually the weighted average capital cost (WACC). This calculation produces a single number, say in cents/kWh. The result should be a curve if the calculation is performed for any number of time periods  $n = 0, 1, 2, \dots, n$ .”

$$LCOE = \frac{\sum_{t=0}^n \frac{C_t}{(1+d)^t}}{\sum_{t=0}^n \frac{kWh_t}{(1+d)^t}} = \frac{\sum_{t=0}^n \frac{C_t}{(1+WACC)^t}}{\sum_{t=0}^n \frac{kWh_t}{(1+WACC)^t}}$$

- Where,  $C_t$  = Costs for time period *t*  
 $d$  = WACC, the discount rate as a fraction per month or per year  
 $t$  = Time period in months or years  
 $n$  = Operational life in months or years

This definition appears simple at first glance. However, the underlying financial models can be quite complicated. Investment grade and bankable models applied for larger EMO investments are particularly sophisticated. For the purposes of this manual, an in-depth discussion of the finer points of LCOE calculation is neither necessary nor appropriate, because

the focus will be mainly on the calculation of levelised costs of **energy saved** and not of **energy supplied**.

**INTRODUCTION TO “ENERGY SAVED” PRODUCTION COST CALCULATIONS**

Similar to calculating the LCOE of energy supply or energy production, the same equation can be applied to calculate the levelised production cost of energy **saved** (kWh(s)). We replace in the equation the term kWh<sub>t</sub> with kWh(s)<sub>t</sub>. Recall that an energy consumer has the choice to either pay the supply price for one unit of energy, or invest in EMOs and pay the price for kWh(s). In the context of this chapter, energy production cost refers to the wholesale price, while energy supply cost refers to the retail price.

If the production cost for one kWh(s) of electricity equals 3 cents and the supply tariff for 1 kWh electricity is 10 cents, management would prefer to invest in EMOs that save electricity at 3 cents/kWh. For instance, a number of EMOs producing 100,000 kWh(s) in 5 years will save electricity costs of 100,000 kWh(s) \* (10 cents – 3 cents) = USD 7,000. More detailed calculations and examples are provided later in this handbook Pay-back period of an EMO.

Energy Auditors as well as Energy Managers should rate EMOs that produce quantifiable energy savings according to the static or dynamic pay-back period. Almost all investors and even more the lenders look at EMO investments with short SPP or short DPP. A short pay-back period signals a high rate of return. It also lowers the investment risk because lenders and equity providers recover their investment faster.

*Example 9:* A room thermostat is set at 24°C instead of 22°C resulting in 7% electricity savings for an air conditioner that consumes 720 kWh per month. At an electricity rate of 13 cents/kWh, the annual electricity cost savings are 12 x 720 x 0.13 x (0.07) = USD 78.62. Calculating the SPP is a “no-brainer” in this case if the air conditioner has a functioning thermostat that can switch the air conditioner compressor on and off. This component is installed in most modern air conditioners. The static pay-back period is as expected to be 0 years since no investment is involved. The measure is a typical good housekeeping measure that conserves energy. The formula to calculate the SPP is

$$SPP = \frac{\text{investment}}{\text{annual energy cost savings}} = \frac{0 \text{ USD}}{78.62 \text{ USD}} = 0 \text{ month}$$

*Example 10:* Assume a 60 W incandescent light bulb with 12 lumens per watt (lm/W) is replaced by a 12 W LED with 60 lm/W. The LED provides the same lighting level as the light bulb, namely 720 lumens. The LED costs USD 6; the incandescent light bulb costs USD 1. Both lights will be used for 6,000 hours per year. Under favourable circumstances, the incandescent light bulb provides lighting for 2,000 hours and must be replaced thrice a year while the LED will provide services for 30,000 hours and last for five years. Electricity costs are 12 cents/kWh. Consequently, annual energy cost savings are (0.060 – 0.012) x 6,000 x 0.12 = USD 34.56. The SPP is,

$$SPP = \frac{\text{investment}}{\text{annual energy cost savings}} = \frac{6 \text{ USD}}{34.56 \text{ USD}} = 2.1 \text{ months}$$

The SSP ignored the annual investment savings of USD 3 for three light bulbs. Including the investment savings for 3 light bulbs we get,

$$SPP = \frac{\text{investment LED}}{\text{annual energy cost} + \text{light bulb savings}} = \frac{6 \text{ USD}}{34.56 \text{ USD} + 3 \text{ USD}} = 1.9 \text{ months}$$

**Observe:** The SPP methodology has two weaknesses. The SSP ignores the profitability of the measure and the time value of money. Nevertheless, most companies judge the attractiveness of an investment by its simple pay-back period and most energy audit reports rate the EMOs based on simple pay-back periods. The next section presents the concept of a benefit/cost ratio of EMOs and explores the thus far absent profitability angle.

**Benefit/cost ratio**

This is usually done from the perspective of the energy customer (first stakeholder test). The benefit/cost ratio (B/C) is one method to look into the profitability of an energy saving investment. Recall the definition of B/C:

$$B/C = \frac{\text{The sum of all benefits throughout the operational life}}{\text{The sum of all costs}}$$

**Example 11:** Example 10 is continued. The annual energy and investment savings were already calculated as 34.56 + 3 = USD 37.56. The operational life of the LED is five years and therefore the benefits amount to 5 x 37.56 = USD 187.8. Consequently,

$$B/C = \frac{187.8}{6} = 31.3$$

In other words, the benefits by far outweigh the costs of investing USD 6 in an LED. Next, the approach is refined to account for inflation on the electricity tariff. Assume the electricity tariff goes up by 3% annually. Consequently, the energy cost savings over a period of five years can be calculated as

$$34.56 \times (1.03)^1 + 34.56 \times (1.03)^2 + \dots + 34.56 \times (1.03)^5 = \text{USD } 188.99.$$

The cost of light bulbs may have also gone up by 5% per year. The resulting avoided investment costs are therefore not only USD 15 but amount to

$$3 \times (1.05)^1 + 3 \times (1.05)^2 + \dots + 3 \times (1.05)^5 = \text{USD } 17.40. \text{ Consequently,}$$

$$B/C = \frac{188.99 + 17.40}{6} = 34.40$$

If the useful life of an EMO becomes too long, say 20 years, it is too cumbersome to calculate by hand the sum of energy cost savings or avoided investment savings that are affected by inflation. Use the following compact equation to calculate the energy or investment savings for any operational life n of an EMO.

$$S_n = C \times (1 + i) \times \left( \frac{(1 + i)^n - 1}{i} \right)$$

- Where, C = Energy cost or investment cost savings in the first year WACC, the discount
- n = rate Last year of operational life Time period in months or years
- i = Inflation rate of costs in percent but applied as a fraction, e.g. 5% = 0.05

Let us further refine the B/C result by assuming that the single investment of USD 6 is financed by a bank. This refinement becomes important later in the section when discussing national LED deployment campaigns managed by a power utility. Assume the annual interest rate of retail banking is 18% and the pay-back period is five years with 60 equal monthly instalments. These key figures represent a typical retail banking scenario, albeit for larger investments and not just a single LED. The monthly instalments (monthly repayment plan) are calculated as follows:

$$A = \frac{I \times q^n \times (q - 1)}{q^n - 1} = 6 \times \frac{(1 + 0.18/12)^{60} \times ((1 + 0.18/12) - 1)}{(1 + 0.18/12)^{60} - 1} = 0.1523 \text{ USD}$$

The same result can be obtained using [www.canadabanks.net/Loan-Calculator.aspx](http://www.canadabanks.net/Loan-Calculator.aspx)

Where,  $A$  = Constant monthly payment to amortise the investment WACC, the discount  
 $I$  = rate Investment  
 $q$  =  $1+i$   
 $i$  = Monthly interest rate as a fraction  
 $n$  = Number of monthly instalments

Therefore  $B/C = \frac{188.99+17.40}{60 \times 0.1523} = 22.86$

**Observe:** Buying a LED with borrowed money will increase the price from USD 6.00 to USD 9.14.

- Depending on the level of refinement of the B/C equation to account for realistic scenarios, the B/C ratio varies between 22.86 and 31.30.
- All cash flows represent nominal cash flows as shown on electricity bills and sales invoices and are not yet discounted.
- To perfect this B/C methodology, the next step would be to apply the time value of money and discount the nominal cash flow time series. Because this EMO is obviously highly attractive, it is not necessary to go to that type of detail.

#### » **Weighted average capital cost (WACC)**

Except for good housekeeping measures, i.e. those measures requiring no or very small investments, all other EMOs need financing in one form or the other. The quickest way to finance EMOs is through a company's equity. However, equity is the most expensive source of capital a company has and EMOs may compete with other projects with higher returns. Also, capital-intensive EMOs will always require a mixture of equity and debt financing. In short, equity is always scarce and expensive and most lenders expect an investor to provide at least 30% equity, sometimes even more, but offer lower interest rates to the company for higher equity levels. Furthermore, debt financing of EMOs is not a mainstream business of lenders because most EMOs are investments in reducing operational costs. Finally, the quantification of resulting energy cost savings can be complex and lenders may question the results.

**Example 12:** A company has tendered for a new boiler. The boiler costs USD 80,000. Company equity is 30% at a 16% expected return and the balance of 70% becomes debt to be paid back at a 9% interest rate. It follows that the  $WACC = 0.30 \times 16\% + 0.70 \times 9\% = 11.1\%$ .

For completeness but only of interest for large EMO investments, the WACC of shareholder-owned companies is calculated differently<sup>1</sup> and is not just based as above on single project financing where a company sets a hurdle rate for the return on equity and a lender proposes an interest rate for the debt.

#### » **Net present value (NPV) perspective for energy consumer**

In the next example, we will calculate the NPV for Example 10 above. The NPV is a different interpretation of the B/C ratio and includes the time value of money. Recall that the NPV

<sup>1</sup> See Investopedia [www.investopedia.com/terms/w/wacc.asp](http://www.investopedia.com/terms/w/wacc.asp) or Money Chimp [www.moneychimp.com/glossary/wacc.htm](http://www.moneychimp.com/glossary/wacc.htm) or WACC calculator [www.wacccalculator.com/](http://www.wacccalculator.com/) – accessed March 17, 2017

represents the increase in wealth of the customer (investor) from implementing the project. Obviously a negative NPV would decrease the wealth of the investor(s) and therefore signal to the investor(s) not to implement the project.

$$NPV_{(n)} = \sum_{t=0}^n \frac{savings_t - costs_t}{(1 + d)^t}$$

- Where, t = Time period in years or months  
 t<sub>0</sub> = End of the time period zero, meaning the start of the time period 1  
 n = Project observation period in years or months. Usually the useful life of the EMO  
 d = Discount rate in % but expressed as a fraction, 16% would be 0.16. Usually the WACC  
 Savings<sub>t</sub> = Energy cost savings as well as any other monetary savings triggered by the EMO in the time period t  
 Costs<sub>t</sub> = Investment costs as well as other costs caused by the EMO in the time period t.

**Example 13:** Retrofitting a furnace or boiler with a heat exchanger to capture some of the waste heat in the stack gas to preheat feed-water or combustion air results not only in fuel cost savings but may at the same time increase electricity costs for operating a blower to overcome the additional pressure drop across the heat exchanger and may also increase maintenance costs.

**Example 14:** Replacing an incandescent light bulb by an LED will not only reduce the cost of electricity, but also eliminate the procurement of additional incandescent light bulbs during the operational life of the LED.

**Observe:** The following,

- The NPV is not just a number. It is also a curve that usually starts with a negative value and should eventually become positive at the end of the useful life of the EMO.
- The NPV calculation considers the time value of money by dividing savings and costs by a factor (1+d)<sup>t</sup> with d being the discount rate of the NPV.
- The discount rate d is in most cases the weighted average capital costs (WACC) of the customer (investor) or a societal discount rate.

**Example 15:** Example 10 assumptions apply at discount rate of 16%. We get

$$NPV_{(n)} = \sum_{t=0}^n \frac{(benefit - costs)_t}{(1 + d)^t} = costs_0 + \sum_{t=0}^n \frac{(benefit - costs)_t}{(1 + d)^t}$$

The first and only Cost<sub>0</sub> at the end of the year zero is USD 6 for one LED. In the following five years the annual benefits are USD 34.56 in electricity cost savings and USD 3 in light bulb cost savings. The NPV at the end of the five-year operational life of the LED equals,

$$NPV(5) = -6 + 37.56/(1.16)^1 + 37.56/(1.16)^2 + 37.56/(1.16)^3 + 37.56/(1.16)^4 + 37.56/(1.16)^5 = -6 + 32.38 + 27.91 + 24.06 + 20.74 + 17.89 = USD 116.98$$

In other words, the replacement of one 60 Watt incandescent light bulb by a 12 Watt LED providing



the same level of light service made the consumer by USD 116.98 richer over a time period of 5 years if we account for the time value of money. Accounting for the time value of money has not been done in the previous sections. Observe that for convenience any electricity tariff inflation or inflation of light bulb prices has not been incorporated but could be included.

#### » Project internal rate of return (IRR)

The project internal rate of return (IRR) is a special discount rate. It is the interest earned on the **outstanding** balance on the project investment. The mathematical definition of the IRR is the discount rate  $d$  at which  $NPV = 0$  at the end of the operational life of the LED. The IRR cannot be calculated by a formula but must be found by iteration. At  $NPV = 0$  we would get  $d = 625\%$ . You can compare this interest earned by the EMO with the paltry few percent one would earn by investing and operating a power plant.

#### » Dynamic pay-back period

The simple or static pay-back period (SSP) was discussed in section 3.4. Calculating the SPP is fully adequate for most EMO investments and does not differ much from the dynamic pay-back period (DPP) in this case. The DPP is a by-product of the NPV curve and can be visualised by drawing the  $NPV(t)$  curve for 60 months. The months for which the NPV curve becomes positive is the dynamic pay-back period. In this case, it is shortly after the end of the second month as shown in the graphic below.

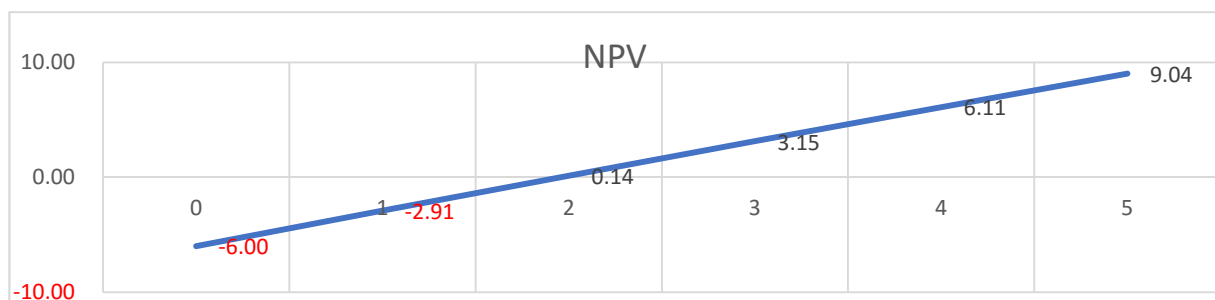

#### Benefit/cost ratio

This ratio is usually calculated from the point of view of the power utility (first stakeholder test). Many power utilities manage large, efficient lighting programs. Some utilities procure “kWh saved” and pay a price for it, or offer rebates for a wide range of EMOs as practised in the USA or South Africa. A few also tender GWh saved as can be seen in the following real-life example from a recent competitive tendering for GWh saved by a Danish power and natural gas distribution utility:

“DONG Gas Distribution and DONG Electricity Distribution hereby announces the tender for delivery of **energy savings** in 2015 and 2016. We are tendering for approximately 100 GWh as a mixture of monthly e-auctions of 5 GWh and an additional 3 e-auctions every fourth month of 15 GWh. The suppliers are prequalified by handing in an accepted certificate describing their quality management system and participating in a meeting with DONG Energy where topics such as the contract, the quality requirements of the energy savings delivered and e-auctions will be elaborated. In order to be prequalified please send a request to: ...”

Literally thousands of national energy savings programmes are implemented by incentivising or tendering energy savings in one form or the other. This section explains in a nutshell



how a power utility under certain conditions will benefit from the EMOs of its customers and may selectively incentivise EMOs for its own financial benefit. US regulators are currently requiring power utilities to prove that procuring new power plant capacity is less expensive than procuring “energy saved” capacity at the same risk levels. The regulators have declared energy savings as an energy resource. Energy savings are also often called the “first fuel” because it is the least expensive energy source.

“Regulators should set clear expectations that Utilities should consider energy efficiency as a RESOURCE and should spent money to PROCURE that resource as they would for other resources in an Integrated Resource Planning (IRP) exercise”. Well informed EMs and EAs will benefit from national incentive schemes and could take advantage of them.

**Example 16:** Consider a power utility managing a national efficient lighting programme to replace incandescent light bulbs with LED lights. A decision has been made to procure in bulk five million 12 Watt LEDs and distribute the investment over a period of two years. The targeted customer group is “lifeline” customers who pay only 3 cents/kWh for the first 75 kWh consumed in a month. However, the electricity supply costs of the power utility for this customer group are much higher at 9 cents/kWh. The utility therefore incurs a financial loss of 6 cents for each kWh supplied and has a vital interest to reduce the power supplied for lighting without lowering the lighting quality or intensity.

Apply the previously introduced B/C ratio equation below from the point of view of a vertically integrated power utility,

$$B/C \text{ of utility} = \frac{\text{some of utility benefits}}{\text{some of utility costs}}$$

- a) First, calculate utility campaign costs under a worst case scenario for the power utility.
  - i. Assume the utility has 12% weighted average capital costs and procures the LEDs for USD 5 per piece on borrowed money for five years, paid back by 60 monthly instalments. The power utility costs are then USD 6.67 per LED if the LEDs are given away for free in the worst case scenario.
  - ii. Program management running costs such as public relations material and the management team and office costs may be USD 2 million over two years or USD 2,259,526 if borrowed money. Consequently, the utility’s total campaign costs are  $6.67 + 2,259,526/5,000,000 = \text{USD } 7.12$  per installed LED.
- b) Sum of total benefits of the utility
  - i. The utility’s life cycle savings are  $(0.060 - 0.012) \times 30,000 \times 0.06 = \text{USD } 86.40$  per LED. In this context savings are in fact the reduction of financial losses of the utility servicing this customer group.
  - ii. We get a B/C ratio of  $86.40/7.12 = 12.1$ .
  - iii. The utility’s benefit/cost ratio would be even higher if the procurement cost for the LED lights is recovered by making them part of the customers’ monthly electricity bill by charging  $6.67/36 = \text{USD } 0.19$  per LED for 36 months. In this case  $B/C = 86.40 / (7.12 - 6.67) = 163$ .
  - iv. Observe that the time value of money was not taken into consideration since it does not carry any significant weight in such a clear-cut case.

We conclude that the B/C test from the standpoint of the electricity customer shows a B/C range of 22.86 to 34.40 depending on how the B/C is calculated. The B/C test from the utility’s point of view shows a B/C ratio of 12 to 163. Both stakeholders enjoy significantly high and robust B/C ratios.

Only when B/C ratios fall below 2 should there be cause for concern and a second look at the financial details to mitigate the risk of ending up with B/C's below 1 for one or both parties. Similar tests should be performed for other stakeholders but will not be covered here. Finally, it is pointed out that in an unbundled power market, the most vulnerable stakeholders are the transmission and distribution companies that may not benefit from EMOs due to loss of sales volumes and sales revenues that cannot be recovered. The reason is that these two entities do not reduce their fuel consumption to generate the electricity.

» **Cost of repayment of debt**

Larger EMO investments are financed by equity and debt as pointed out in section 3.6. This section discusses the two most common methodologies of lending and how debt is repaid by the borrower. The section applies only to large EMO investments and long-term loans. Almost all lenders offer loan repayment plans based on fixed instalments, meaning a series of equal payments per month, quarter, or year (Plan 1), or the loan is paid back in equal repayments of the principle (Plan 2). For demonstration purposes the repayment plans presented here are based on annual repayments, although a loan is usually paid back on monthly instalments. Repayment plans are usually prepared with the help of custom-tailored Excel™ spreadsheets.

**Example 17:** A company's principal banker has agreed to partially finance an EMO investment and lend L= USD 80,000 ("principle"). Annual effective interest is i=14%. Repayment is based on Plan 1 in N = 6 equal annual instalments. First calculate the annual instalment,

$$A = \frac{i \times L}{(1 - (1 + i)^{-N})} = \frac{0.14 \times 80,000}{(1 - (1 + 0.14)^{-6})} = \frac{11,200}{(1 - 1.14^{-6})} = \frac{11,200}{1 - 0.4556} = 20,573 \text{ USD}$$

**Note:** A can also be calculated by applying. The result will be the same although the equation looks completely different. Next, calculate the principle portion  $P_n$  due at the end of a year n,

$$P_n = A \times (1 + i)^{-(1+N-n)}$$

Now calculate the interest payment due at the end of the year n,

$$I_n = A - P_n$$

Finally, calculate the remaining outstanding debt after the end of the year n,

$$R_n = \frac{I_n}{i} - P_n$$

Repayment plans provided by the lender to the borrower typically look like those shown below (for Plan 1 and Plan 2). The plans list the cash flow streams split up into total annual repayment (Column 1), principle repayment (Column 2), interest paid (Column 3) & outstanding loan balance (Column 4).

Table 1.11: Typical repayment plan (Plan 1)

End of year				
Loan USD 80,000, effective annual interest rate 14% (Plan 1)				
Column 0	Column 1	Column 2	Column 3	Column 4
	Annual repayment	Principal repayment	Interest paid	Balance
0				80,000.00
1	20,572.60	9,372.60	11,200.00	70,627.40
2	20,572.60	10,684.76	9,887.84	59,942.64

<b>End of year</b>				
<b>Loan USD 80,000, effective annual interest rate 14% (Plan 1)</b>				
<b>Column 0</b>	<b>Column 1</b>	<b>Column 2</b>	<b>Column 3</b>	<b>Column 4</b>
3	20,572.60	12,180.63	8,391.97	47,762.01
4	20,572.60	13,885.92	6,686.68	33,876.09
5	20,572.60	15,829.95	4,742.65	18,046.14
6	20,572.60	18,046.14	2,526.46	0.00
<b>Total</b>	<b>123,435.60</b>	<b>80,000.00</b>	<b>43,435.60</b>	

*Example 18:* The structure of Plan 2 is more straightforward and easier to explain. The six equal repayments of the principle are  $80,000/6 = \text{USD } 13,333.33$  (Column 2). At the end of each year the remaining balance of the outstanding principle is reduced by USD 13,333.33 (Column 4). Interest in the year n is paid on the outstanding balance at the end of the previous year (n-1) (Column 3). The total annual payment in Column 1 is the sum of repayment of the principle plus interest paid on the outstanding balance (Column 2 + Column 3).

*Observe:* The total amount paid to lenders of USD 103,999 under Plan 2 is smaller than the USD 123,436 paid under Plan 1. However, that does not necessarily mean Plan 2 is the better option for the investor. An investment grade or bankable appraisal would most likely pick Plan 1 as the preferred option for the lender as well as for the investor for various risk mitigation reasons.

Table 1.12: Typical repayment plan (Plan 2)

<b>End of year</b>				
<b>Loan USD 80,000, annual interest rate 14% (Plan 2)</b>				
<b>Column 0</b>	<b>Column 1</b>	<b>Column 2</b>	<b>Column 3</b>	<b>Column 4</b>
	<b>Annual payment</b>	<b>Principal repayment</b>	<b>Interest paid</b>	<b>Balance</b>
0				80,000.00
1	24,533.33	13,333.33	11,200.00	66,666.67
2	22,666.53	13,333.33	9,333.19	53,333.33
3	20,799.72	13,333.33	7,466.39	40,000.00
4	18,932.91	13,333.33	5,599.58	26,666.67
5	17,066.11	13,333.33	3,732.77	13,333.33
6	15,199.30	13,333.33	1,865.97	0.00
<b>Total</b>	<b>103,998.60</b>	<b>80,000.00</b>	<b>39,197.90</b>	

» *The energy cost/depreciation cost ratio aids identifying EMOs*

The major challenge with energy audits in larger companies is where to start the audit. The choice involves hundreds if not thousands of energy-consuming devices plus dozens of processes. A simple indicator such as annual energy cost divided by annual depreciation cost (E/D) represents a quick way to identify a group of interesting EMOs such as energy cost-intensive equipment that can be replaced with more energy efficient options.

During this stage, an EM or EA does not need the skills to judge and estimate the energy efficiency of the equipment. Instead it is more important for him to know the present equipment options that offer state-of-the-art efficiency in the market. The volume of energy consumed is not always what makes an energy-consuming technology an attractive EMO. It is also the art of preventing a firm’s management from making its next irreversible investment error by

procuring energy cost-intensive equipment based on least investment cost instead of least life cycle cost decision-making.

**Example 19:** An **irreversible** investment error in energy-intensive equipment is best explained by a striking example of the opposite, a **reversible** investment error. Assume an industrial firm pays 15 cents/kWh for electricity and operates an electric motor for 5,000 hours a year. The firm buys an 11 kW (15 hp) inefficient EFF-3 class motor for USD 1,000 on Monday. A convincing Energy Auditor drops by on Tuesday and the firm changes its mind, junks the 2-day old motor on Wednesday and replaces it with a more expensive EFF-1 class motor bought on Thursday for USD 1,300. Despite a costly USD 1,000 investment error, the firm will still come away with a financially attractive total investment of  $\text{USD } 1,000 + 1,300 = \text{USD } 2,300$ .

This investment is still profitable due to the very high E/D ratio of the annual electricity cost divided by the annual equipment depreciation of an electric motor. The annual electricity costs of this electric motor, which runs at an 80% load, are  $0.8 \times 11 \times 5,000 \times 0.15$  equalling USD 6,600 in its first year of operation or at least USD 132,000 over twenty years assuming constant electricity prices. In other words, the total life cycle cost of the inefficient electric motor is  $132,000 + 1,000 = \text{USD } 133,000$  of which 99% are energy costs and 1% represent the investment in the motor. The simple book depreciation of the motor over twenty years at USD 50 per year results in  $E/D = 6,600/50 = 132$ . Observe that a ratio of 100 means the annual depreciation cost is only 1% of the annual energy cost. One may refine the E/D ratio by accounting for the annual inflation of energy costs or, instead of a simple straight line book depreciation, use annual amortisation costs at the company's WACC. However, these details do not matter at very high E/D ratios.

**Example 20:** Try the same calculation with an inefficient 300 litre refrigerator costing USD 400, assuming an annual electricity consumption of 350 kWh and a 20-year lifetime. The  $E/D$  ratio of  $52.5/20 = 2.6$  indicates a financially risky technology and a potentially irreversible investment error, because the energy consumer cannot replace the inefficient refrigerator with a more efficient one just a few months later without losing money at this low E/D ratio.

A firm's Energy Manager should therefore roughly classify major energy-consuming equipment for retrofitting or replacement based on their actual E/D ratios. Or, even better, enter a new column in the equipment inventory list to show E/D ratios. Having an idea about the E/D ratios of energy-consuming equipment is also important for the procurement manager of a company. One would normally procure equipment with a high E/D ratio by competitive tender based on least life cycle cost (LLCC) offers.

#### » *Least life cycle cost assessment of EMOs*

The previous two examples demonstrate that procurement of energy-intensive equipment should be based on life cycle costs (LCC) and selecting the preferred technology should be based on least life cycle cost (LLCC) criteria and not on least capital investment. For further details on how LLCC strategies can benefit a company as part of procurement procedures see Article 68(2) of Directive 2014/24/EU and Article 83(2) of Directive 2014/25/EU. Preparing EMs and EAs for LLCC tendering procedures is part of EM and EA training.

**GENERAL COST CALCULATION**

» **Cost of electricity supplied versus cost of electricity saved**

This section sheds some more light on how to calculate the production cost of electricity as well as production cost of electricity saved and compare the two. The same approach is applicable for other energy resources such as oil, oil derivatives, gas, coal and biomass.

**PRODUCTION COSTS OF ENERGY (LCOE)**

Recall the equation

$$LCOE = \frac{\sum_{t=0}^n \frac{C_t}{(1+d)^t}}{\sum_{t=0}^n \frac{kWh_t}{(1+d)^t}} = \frac{\sum_{t=0}^n \frac{C_t}{(1+WACC)^t}}{\sum_{t=0}^n \frac{kWh_t}{(1+WACC)^t}}$$

**Example 21: Calculation of a 500kW ‘heavy-duty captive’ diesel generator**

Take the example of a heavy-duty captive 500 kW diesel generator set, with a plant capacity factor of 60%, an operational life of 20 years and an overnight turnkey investment cost of USD 200,000. The average diesel fuel consumption is 0.3 litres per kWh sent to the facility. Assume the weighted average capital costs (WACC) of the company at 12%. The diesel fuel price of USD 0.6/litre is escalated at 2% per year. Other annual operational costs are 5% of the initial investment, also escalated at a rate of 6%. The residual value at the end of 20 years is conservatively set to zero. We can then calculate:

- ⇒ Annual electricity output 500 kW x 0.60 x 8,760 = 2,628,000 kWh
- ⇒ End of year 0 annual fuel cost 2,628,000 x 0.3 = USD 788,400 = E<sub>0</sub>
- ⇒ End of year 0 other operational cost 200,000 x 0.05 = USD 10,000 = M<sub>0</sub>

<b>EoY</b>	<b>Investments</b>	<b>Energy cost</b>	<b>O&amp;M cost</b>	<b>Total USD</b>	<b>kWh</b>
0	200,000	0	0	200,000	2,628,000
1	0	x (1.02/1.12) <sup>1</sup>	x (1.06/1.12) <sup>1</sup>	727,471	x (1/1.12) <sup>1</sup>
2	0	x (1.02/1.12) <sup>2</sup>	x (1.06/1.12) <sup>2</sup>	662,857	x (1/1.12) <sup>2</sup>
3	0	x (1.02/1.12) <sup>3</sup>	x (1.06/1.12) <sup>3</sup>	603,993	x (1/1.12) <sup>3</sup>
...	0				
20	0	x (1.02/1.12) <sup>20</sup>	x (1.06/1.12) <sup>20</sup>	124,773	x (1/1.12) <sup>20</sup>
<b>Total</b>	<b>200,000</b>	<b>6,802,913</b>	<b>117,930</b>	<b>7,120,842</b>	<b>22,257,698</b>
<b>LCOE</b>	USD 7,120,842 / 22,257,698 = <b>32 cents/kWh</b>				

It is important to not neglect price escalations for energy that could significantly influence the LCOE because the useful life of a diesel generator set is between 10 and 30 years depending on size, capacity factor, fuel quality, rpm speed, and maintenance level.

The time series should begin with end of year (EoY) = 0. An online reference calculator for simple LCOE calculations is [www.nrel.gov/analysis/tech\\_lcoe.html](http://www.nrel.gov/analysis/tech_lcoe.html). Further documentation can be found at [www.nrel.gov/docs/legosti/old/5173.pdf](http://www.nrel.gov/docs/legosti/old/5173.pdf)

**PRODUCTION COST OF ELECTRICITY SAVED**

**Example 22: Recall Example 10:** Assume a 60 Watt incandescent light bulb with 12 lm/W is replaced by a 12 Watt LED with 60 lm/W. The LED will provide the same level of lighting service of 720 lumens for 6,000 hours/year as the light bulb did. The LED costs USD 6. The useful life of the LED is 30,000 hours. Consequently, the annual savings in kWh are  $6000 \times (0.060 - 0.012) = 288$  kWh. Apply the LCOE formula to calculate the price the investor pays for 1 kWh saved at a WACC of 12%.

- i. Accumulated discounted cost in 5 years:  $6 + 0/(1.12)^1 + 0/(1.12)^2 + 0/(1.12)^3 + 0/(1.12)^4 + 0/(1.12)^5 =$  USD 6
- ii. Accumulated discounted kWh saved in 5 years:  $288/1.12^1 + 288/1.12^2 + 288/1.12^3 + 288/1.12^4 + 288/1.12^5 = 257.14 + 229.59 + 204.99 + 183.03 + 163.42 = 1,038.17$  kWh
- iii. Production price for 1 kWh **saved** equals  $6/1,038.17 = 0.6$  cents/kWh.

In general, a financially attractive production price of 1 kWh saved should be in the range of 0 to 3 cents. Compare this price range to production costs such as

- Retail electricity prices of fossil fuel power utilities between 4 and 35 cents/kWh, depending on the energy supply cost for coal, gas, or oil, power plant size, technology and capacity factor.
- Very recent successfully negotiated production prices as low as 3 cents/kWh for large utility-scale (>300 MW) PV solar power plants in sunny regions with a net output of 1,800 kWh/kW per year;
- Recent production prices of 5 cents/kWh at auctions for 500 MW highly distributed small-scale rooftop solar PV plants also in sunny regions.
- iv. It thus comes as no surprise that energy savings are known as the “first fuel”.

**ENERGY SERVICE CONTRACTS**

An energy service contract is normally signed between the industrial facility (client) and the energy service company (ESCO). The contract allows the client to transfer risk of generating energy and focus on its core business and to reduce operating costs.

The energy service contract is usually employed as a form of outsourcing where the client expects a reduction in cost than if energy (electrical and thermal) was self-generated. This type of contract operates on the premise that if energy production were outsourced, the total cost to the client, including the transaction cost of negotiation and relationship management with the ESCO, would be less than if energy was self-produced. A typical energy service contract will cover the following amongst others:

1. Define the scope of operations: The contract states the type and quantum of energy required by the client: Does the client require mostly thermal or electrical energy?
2. Define the duration of contract: The contract should categorically state the duration for which it runs.
3. Define pricing of energy over the duration of the contract: The client and ESCO agree on a pricing template to be used for the duration of the contract this template which could be a chart already laid out or a financial model to be activated depending on conditions is clearly and transparently spelt out.
4. Define technical aspects: The energy service contract should clearly define all technical aspects required by the client and agreed to by the ESCO. Issues such as power factor correction, maintenance schedules of production lines, expansion of factory operations are dealt with in the contract.



» **Energy service contract models**

Various models are employed for energy service contracts

1. **Shared savings** in which savings are shared between client and the ESCO at an agreed percentage over an agreed duration. In this model, the ESCO finances the cost of equipment (capital expenditure) through equity (own funds) or debt.
2. **Guaranteed savings** in which the ESCO assumes the project risk though capital expenditure is borne by the client. Here, the ESCO guarantees the quantum of energy and savings to be made. In the event of not meeting agreed figures, the ESCO makes up for the difference.
3. **Lease rental** in which the ESCO is responsible for capital expenditure. The client makes regular payments to cover capital expenditure and interest based on verifiable energy and cost savings made. Usually at the end of the lease period, ownership is transferred to the client.
4. **Build-own-operate-transfer** in which the ESCO designs, builds, finances, owns and operates the equipment for a defined period of time before transferring ownership to the client. In this model, the client enters into long term supply contracts with the ESCO and is charged according to service delivered.
5. **Build-own-operate** is a form of public-private partnership (PPP) in which the ESCO provides energy services to a government owned facility. The government does not provide direct funding but grants special incentives to the ESCO as a form of cost recovery.

The following resources are recommended for a deeper review of the subject:

- “Model ESCO performance contract” – Koshy Cherail for AEEE with support from Shakti Sustainable Energy Foundation, available at [www.aeee.in/wp-content/uploads/2016/03/AEEE-Model-EPC-Template.pdf](http://www.aeee.in/wp-content/uploads/2016/03/AEEE-Model-EPC-Template.pdf)
- Developing model ESCO performance contracts (EPCs) for industrial projects” – Alliance for an Energy Efficient Economy with support from Shakti Sustainable Energy Foundation, available at [www.aeee.in/wp-content/uploads/2016/03/AEEE-Report-ESCO-EPC1.pdf](http://www.aeee.in/wp-content/uploads/2016/03/AEEE-Report-ESCO-EPC1.pdf)

## 1.6. ENERGY MONITORING SCHEDULE

### ENERGY MONITORING

This is the regular collection of data on energy use patterns. Its purpose is to determine when and why energy consumption deviates from an established pattern, and to serve as a basis for management to take action where necessary. Energy monitoring is essentially aimed at finding options to trigger energy efficiency saving measure and/or to conserve energy in a financially attractive and technically viable way.

This chapter discusses how to handle collected data in an organised manner within an energy consumption monitoring schedule.



### » *Data sources*

The Energy Manager of an organisation is responsible for the energy monitoring schedule. Part of designing the energy monitoring schedule is the identification of data sources. A great deal of intelligence about the operation of the plant can be gained through the analysis of data that is usually readily available.

Many sources of existing data can be utilised, both within the organisation and external to it. The types of data and their sources typically include the following:

- **Historical energy consumption data:** Invoices for purchased energy of each type should normally be available from the finance department;
- **Metered energy consumption:** Often the electricity distribution company that supplies electricity will be able to provide historical data on demand and consumption;
- **Plant configuration:** The Energy Manager needs to know plant dimensions as well as the layout of electricity, steam, hot and cold water, compressed air systems, etc. along with the location of any existing meters;
- **Production data:** As discussed later in this module, the correlation of energy consumption to production is a step in the analysis of plant performance;
- **Plant equipment nameplate data:** The design energy characteristics of the equipment in the plant can usually be taken from nameplates; however, it is important to realise that the actual operating characteristics may be quite different depending on the age, condition, and loading of these systems.

### » *Historical data analysis – analysing the energy tariff*

Once available data has been identified, the Energy Manager is in a position to determine what additional data needs to be collected by direct measurement.

Prior to the site analysis, the Energy Manager should be able to do a great deal of analysis to understand energy purchasing and the usage of the facility. This historical analysis should include both the assessment of the various energy prices and the consumption-related costs as well as the correlation of consumption to the key energy “drivers” that determine the rate of energy use.

#### **SOURCES OF PURCHASED ENERGY**

Energy is purchased in a variety of forms, with varying energy content as shown in below. This information will be useful when analysing the unit cost of energy from the various sources, and later when performing savings calculations.

An important step in implementing energy monitoring is understanding how the organisation purchases electricity. In part, this relates to metering as done by the supply utility. Although a number of metering technologies are in use and they differ in various ways, the key issues for all metering approaches are essentially the same, including:

- Whether or not maximum demand is metered and recorded,
- How data is measured, stored and displayed.

#### **TABULATING ENERGY PURCHASE DATA**

Energy consumption data is available from the organisation’s accounting records. Energy supplier invoices contain valuable information about consumption that may be tabulated.

Figure 1.7 below is an example of electricity cost tabulation in an Excel spreadsheet. This sheet contains consumption data collected from bills or invoices and derived figures that form part of the analysis. An informative graphical presentation of the key data and derive values is also provided. Starting with the basic historical billing data, a number of calculations may be performed. Some of the main calculations are:

**kWh/day:** kWh in period ÷ days. Since reading periods can vary, kWh/day is more useful for spotting consumption trends than billed kWh.

**Electrical load factor (LF)** is the energy consumed relative to the maximum energy that could have been consumed if the maximum (kW) demand had been maintained throughout the billing period. All information required for this calculation can usually be found on electricity bills. Mathematically, this is written as follows:

$$LF = \frac{E}{P_p \cdot 24h \cdot n}$$

- Where, LF = Load factor
- E = Energy used in period [kWh]
- P<sub>p</sub> = Peak power in period [kW]
- n = Number of days in period

A high, short duration peak demand will lower the load factor, whereas a more consistent rate of energy consumption will raise the load factor.

**Example 23: Load factor (Sample electricity bill calculation)**

Assume that two sample facilities consume 2.5 megawatt hours over a billing period of 30 days. Facility A has a maximum demand of 250 kW, while Facility B has a maximum demand of 50 kW. Based on the tariff given for the period 1 to 30 May, the billings for the two facilities during this period are as follows:

Facility A			
Fixed charge			₺ 2,500
Demand charge	6.4 ₺/kW	1,500 kW	₺ 9,600
Consumption	0.008 ₺/kWh	250,000 kWh	₺ 2,000
<b>Total</b>			<b>₺ 11,850</b>
Facility B			
Fixed charge			₺ 250
Demand charge	6.4 ₺/kW	500 kW	₺ 3,200
Consumption	0.008 ₺/kWh	250,000 kWh	₺ 2,000
<b>Total</b>			<b>₺ 5,450</b>

The respective load factors can be calculated as follows:

**Facility A**

$$LF = \frac{250,000kWh}{1,500kW \cdot 24 \frac{h}{d} \cdot 30d} = 0.23$$

$$LF = \frac{250,000kWh}{500kW \cdot 24 \frac{h}{d} \cdot 30d} = 0.69$$

Facility A has a load factor of 23% and an average energy cost of ₦ 0.047 per kWh. Facility B has a load factor of 69% percent and an average energy cost of ₦ 0.022 per kWh. Thus, the load factor is inversely proportional to the average cost per kWh for similar facilities with the same rate.

Load factor can be used as a barometer for a facility’s use of electricity, by alerting us to potentially excessive demand for the energy consumed.

[ C:\Project Files\Audit Manual\Spreadsheets\Electricity Cost.xls\Electricity Consumption Data ]

Billing Date	Metered kVA	Metered kW	Power Factor	Billed kW	Energy kWh	Days	Daily kWh	Load Factor	Demand Cost	Energy Cost	Adjust (+/-)	Sub Total	Total Cost
01/01/99		1,800.0		1,800.0	1,006,703	30	33,557	78%	\$21,250	\$50,365	(\$11,147)	\$71,615	\$64,701
02/01/99		1,900.0		1,900.0	1,206,383	31	38,916	85%	\$22,750	\$56,441	(\$13,204)	\$79,191	\$70,607
03/01/99		1,400.0		1,400.0	842,286	28	30,082	90%	\$15,250	\$42,144	(\$9,263)	\$57,394	\$51,501
04/01/99		1,850.0		1,850.0	1,102,176	31	35,554	80%	\$22,000	\$53,315	(\$12,132)	\$75,315	\$67,606
05/01/99		1,870.0		1,870.0	1,213,021	30	40,434	90%	\$22,300	\$56,641	(\$13,252)	\$78,941	\$70,287
06/01/99		2,200.0		2,200.0	1,339,599	31	43,213	82%	\$27,250	\$60,438	(\$14,716)	\$87,688	\$78,080
07/01/99		1,560.0		1,560.0	850,195	30	28,340	76%	\$17,650	\$42,540	(\$9,438)	\$60,190	\$54,304
08/01/99		1,570.0		1,570.0	948,747	31	30,605	81%	\$17,800	\$47,467	(\$10,429)	\$65,267	\$58,677
09/01/99		1,950.0		1,950.0	1,213,798	31	39,155	84%	\$23,500	\$56,664	(\$13,308)	\$80,164	\$71,536
10/01/99		2,300.0		2,300.0	1,373,054	30	45,768	83%	\$28,750	\$61,442	(\$15,111)	\$90,192	\$80,337
11/01/99		2,100.0		2,100.0	1,347,059	31	43,454	86%	\$25,750	\$60,662	(\$14,731)	\$86,412	\$76,699
12/01/99		2,400.0		2,400.0	1,024,475	30	34,149	59%	\$30,250	\$50,984	(\$11,685)	\$81,234	\$74,418
Totals/Max	2,400.0			2,400.0	13,467,496	364			\$274,500	\$639,104	(\$148,415)	\$913,604	\$818,752



Figure 1.7: Sample electricity consumption spreadsheet

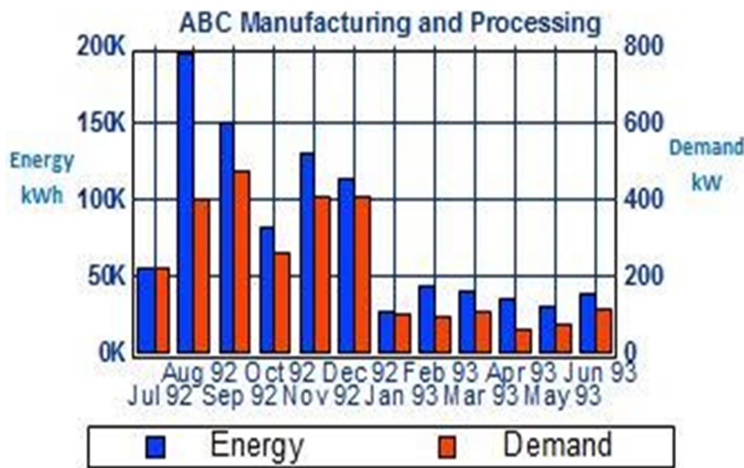

Figure 1.8: Historical demand and energy graph

**Cost calculations:** Cost of demand, energy and total cost.

**Cost distribution between demand and energy:** These numbers, along with load factor, can indicate trends or anomalies in energy usage and demand. This distribution is generally expressed in percent, and was calculated for the sample bill in the previous module.

**Energy and demand intensity:** Dividing the annual energy consumption (kWh) and the annual peak demand (kW) by the annual production unit can provide useful comparisons to other similar operations. In industries with a high number of products, energy intensity is usually defined as energy input divided by a monetary unit.

**Average energy cost (blended rate):** The average cost of the firm is simply the entire electrical bill (including demand and energy costs as well as any other fixed or variable service charges or levies, if any) divided by the billed energy (kWh). *It is important that the average energy cost not be used in the calculation of savings.*

A simple but effective way to view electricity consumption history is in the form of a graph as shown in Figure 1.7.

» **Load factor and utilisation factor**

As noted above, the load factor (LF) is the actual energy consumed in kWh for electricity divided by the energy that would have been consumed had the maximum demand of the billing period been maintained for the entire period.

The **utilisation factor (UF)** refers to the usage rate (occupancy, production, etc.) of a facility expressed as a percentage. For comparative purposes, this should be calculated over the same period of time as the electrical load factor (24 hours, one week, one month, etc.).

Completing this exercise is an initial step for determining the present use of electricity and a good place to start your search for future savings opportunities. If there is a significant difference between the UF and the LF, further investigation is probably warranted. See the following example.

**Example 24: UF and LF comparison for an industrial plant**

To illustrate this comparison, consider an industrial facility that exhibited the following properties:

- Maximum demand: 1,350 kW
- Consumption in a 28-day billing period: 806,400 kWh during three eight-hour shifts:
  - Shift 1: 100% production
  - Shift 2: 60% production
  - Shift 3: 20% production

$$LF = \frac{806,400kWh}{1,350kW \cdot 24 \frac{h}{d} \cdot 28d} = 0.89$$

Now, for the UF:

- 1/3 of a production day at 100% production = 33.3%
- 1/3 of a production day at 60% production = 20%
- 1/3 of a production day at 20% production = 6.7%
- Factor of utilisation for one production day = 60% (sum of above)
- Number of production days in period (no production on weekends) = 20

$$UF = \frac{\text{Production day UF} \cdot n_p}{n}$$

Where,  $n_p$  = Number of production days in the period  
 = Days of the period

In this example:

$$UF = \frac{0.6 \cdot 20d}{28d} = 0.43$$

Comparison of the load factor and utilisation factor reveals a poor correlation, 89% versus 43%. A high LF can result from excessive energy consumption during the month, and further investigation of the demand pattern is probably warranted.

**LOAD DURATION CURVE**

A load duration curve is a plot of the time that a site’s electrical demand meets or exceeds a given level. Load duration curves are used by electrical utilities at a system level to plan generation schedules. However, they are also useful, in addition to the demand profile, in characterising consumption patterns at the site level, and planning demand management activities.

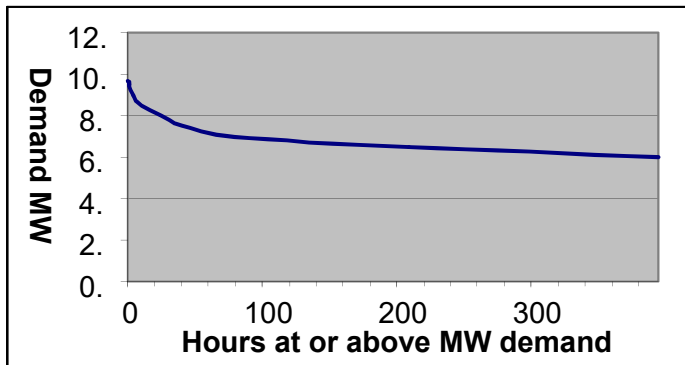

Figure 1.9: Load duration curve

generation schedules. However, they are also useful, in addition to the demand profile, in characterising consumption patterns at the site level, and planning demand management activities.

As an example, Figure 1.9 shows a load duration curve for an industrial site. This graph shows the site’s “electrical footprint” – i.e. the power demand over a monthly period.

The objective is to flatten the curve as much as possible. This will reduce the line capacity required and therefore the line charges. In this example, the curve shows that there are about five hours where 95% of the load is exceeded – so if the customer could move those load hours (if the operation of the plant allowed it), they would achieve a 5% reduction in line capacity – which could represent a significant savings.

» *Tabulation of fuel consumption data*

Wherever possible, ensure that you record data in physically measurable units (cubic meters, kWh, etc.). Avoid using monetary units as they can fluctuate over time (e.g. via utility rate changes, product price changes, etc.). Where two different energy sources provide thermal energy data to the same process, it may be necessary to convert them to a common unit. In a spreadsheet program, units may be adjusted as needed after the quantities are entered in their original units.

Table 1.13: Tabulation of fuel consumption data

<i>ABC Widgets Inc. Thermal energy breakdown</i>		
<i>Date</i>	<i>Purchased oil (Litres)</i>	<i>Total energy (G)</i>
Jan-94	531,000	20,521
Feb-94	559,000	21,599
Mar-94	520,000	20,081
Apr-94	420,000	16,609
May-94	445,000	17,182
Jun-94	237,000	9,137
Jul-94	256,000	9,868
Aug-94	284,000	10,964
Sep-94	193,000	7,431

<b>ABC Widgets Inc. Thermal energy breakdown</b>		
<b>Date</b>	<b>Purchased oil (Litres)</b>	<b>Total energy (G)</b>
Oct-94	354,000	13,651
Nov-94	497,000	19,183
Dec-94	507,000	19,557
<b>Totals:</b>	<b>4,803,000</b>	<b>185,783</b>

*Interpolating periodic data (if necessary):* Normally it is easiest to analyse energy use on an actual-month basis. In the case of fuel delivered or meters read at uneven intervals (e.g. fuel oil delivered by truck), it is necessary to interpolate between deliveries to attribute the fuel use to the proper month in which it was consumed.

» **Tabulation of other data**

After gathering and tabulating energy use data, it is necessary to determine what factors influence energy usage and what data, if any, can be gathered about these factors. These may include.

**Table 1.14: Factors influencing energy use**

<b>Factor</b>	<b>Data</b>	<b>Units</b>
Products	Product quantities	Quantities, volumes, seasonal variations, etc.
Weather	Outside air temperature	Degree-days
Occupancy	Occupied time	Hours, shifts, days, schedules etc.

Continuing the example of fuel consumption, we determine that weather and production are the only two factors influencing the tabulated fuel consumption. The weather (degree-day data from the local weather office) and production data (numbers of widgets) for the period corresponding to the fuel data are gathered and entered into Table 1.15.

**Table 1.15: Thermal energy use data analysis**

<b>ABC Widgets Inc. Thermal energy breakdown</b>					
<b>Date</b>	<b>Purchased oil (litres)</b>	<b>Total energy (GJ)</b>	<b>Heating degree-days</b>	<b>Cooling degree-days</b>	<b>Product (000's) kg</b>
Jan-04	531,000	20,521	0.0	27.9	48
Feb-04	559,000	21,599	0.0	28.0	64
Mar-04	520,000	20,081	0.0	0.0	59
Apr-04	420,000	16,609	15.0	0.0	64
May-04	445,000	17,182	99.2	0.0	89
Jun-04	237,000	9,137	150.0	0.0	75
Jul-04	256,000	9,868	179.8	0.0	81
Aug-04	284,000	10,964	164.3	0.0	90
Sep-04	193,000	7,431	120.0	0.0	61
Oct-04	354,000	13,651	0.0	0.0	55
Nov-04	497,000	19,183	0.0	0.0	79
Dec-04	507,000	19,557	0.0	0.0	45
<b>Totals:</b>	<b>4,803,000</b>	<b>185,783</b>	<b>728.3</b>	<b>55.9</b>	<b>810</b>

The effects of varying weather conditions should always be considered as it is a significant variable when considering thermal energy requirements.



### » Comparative analysis

Based on the historical data analysis, the Energy Manager is able to compare the facility's energy performance to other comparable plants as well as the subject plant itself over the period for which data are available. Energy performance indices, if used carefully, are useful devices for a comparative analysis.

#### DATA ANALYSIS

By tabulating bills over time and doing these simple calculations you can achieve the following benefits:

- Obtaining an initial correlation between the energy and demand figures, and the operation of the plant. A correlation example is provided in the next section.
- Setting a savings objective or target.
- Revealing and subsequently flagging any unexpected increases in demand and/or consumption. Later you can track down and, where necessary, correct the condition causing the increase.
- Confirming the savings expected from any energy conservation measures that have been implemented. As an example, you should be able to ensure that new building management systems are delivering savings on an on-going basis.
- Evaluating and comparing the energy and demand of one process/building to another or to standards ("benchmarks") on the basis of area or energy density.

These types of calculations are also known as energy use intensity (EUI), energy budget, and demand density.

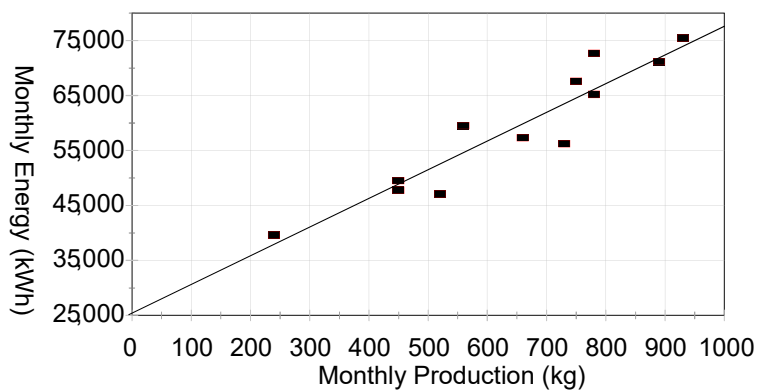

Figure 1.10: Energy consumption versus production

The consumption of energy in many industrial plants is strongly dependent upon the level of production. The comparison of energy consumption levels with production levels can reveal patterns that are otherwise not obvious. Note that this approach does not work in industries with a highly diverse production mix. It is applicable, however, in situations with a stable product mix.

Graphs are simple but powerful analysis tools. The above graph can be easily prepared from the tabulated data. It tells us how the overall energy consumption level of the plant varies with the production level assuming there is no change in the product mix and other variables.

The squares represent the actual monthly consumption for the various production levels. The trend line intercepts the y-axis at about 25,000 kWh; that is, this amount of energy is still being consumed at zero production. The line represents the "best fit" of the points.

This graph suggests a number of questions, some of which are:

- Why is there a wide variation in energy per unit of production?
- Why is 25,000 kWh consumed at a level of no production?



- Could the plant be operated so as to consistently achieve a best fit close to the best performance indicated (the lowest points)?
- What targets for energy use reduction can be set?

From this simple analysis, it is clear that there may be an opportunity at this plant to reduce the level of energy consumption related to production. Furthermore, by investigating the production records for the specific months when the energy consumption was the lowest it may be possible to determine the type of actions or production schedules that will achieve these savings.

#### **BENCHMARK COMPARISON**

In the previous example, we examined the variation of energy use as a function of production. The data used to prepare the graph could also be used to develop an overall energy consumption measure per unit of production. This figure is called the specific energy consumption, and for this example would be measured in kWh/kg. The energy unit depends upon your situation, common energy units are kWh, MJ or GJ.

For the data in the previous example the specific energy consumption is:

- Maximum month: 139 kWh/kg
- Minimum month: 77 kWh/kg
- Average for period: 92 kWh/kg

These figures highlight the range of variation present and provide a point of comparison to an external benchmark. As an example, industry data might be available for this type of plant that states the following:

- Industry average: 85 kWh/kg
- Best practice: 65 kWh/kg

The best practice figure represents the specific energy use achievable using the best known operational and equipment practices. By comparing these values to our own we can draw a number of simple conclusions:

- On average we may be able to achieve a 7 to 8% reduction in the SEC.
- Using best practices, which may require extensive operational and technological improvements, there could be a savings of up to 30%.

It is necessary to be cautious when making this type of comparison, since we don't know what the average industry practice is, and the plant being audited may never be able to achieve best practice standards. But it does provide a starting point. Moreover, firms are interested in energy cost savings. Consequently, management would expect cost-effective and technically viable recommendations from an Energy Auditor and not just a benchmark comparison or savings in tonnes of CO<sub>2</sub>.

What is clearly demonstrated by the comparisons, both internal and external, is that there is some opportunity for improvement. A modest target of 5% in this case may be a good starting point.

As noted earlier, specific energy consumption (SEC) is a figure often used by industry. It is simply energy use divided by an appropriate production measure (e.g. tonnes of steel, number of widgets). It can be calculated for any fixed time period, or by production batch. SEC values need to be treated with care because their variability may be due to factors such as economies of scale or production problems, rather than energy management *per se*.

There are many process benchmarking schemes based on SEC and their ease of use makes them attractive to several companies. However, some practitioners are strongly averse to SEC, regarding it as too simplistic and flawed. On the other hand, the EU emissions trading system has established SECs at an acceptable accuracy level for 50 energy intensive industrial products, applying a rather complicated methodology require data monitoring instrumentation and methodologies usually not practiced in industry.

» **Energy monitoring**

Energy monitoring and targeting (M&T) refers to activities that use information on energy consumption as a basis for control and managing consumption to achieve reductions. The two component activities are distinct yet inter-related.

As mentioned in the beginning of this section, **monitoring** is the regular collection of information on energy use, whereas **target setting** is the identification of energy consumption levels, which is desirable in terms of creating management objectives.

Monitoring and target setting have elements in common and they share much of the same information. Generally, however, monitoring comes before target setting because without monitoring you cannot know precisely where you are starting from, or decide if a target has been achieved.

**DATA AND INFORMATION**

Within M&T activities, data and information are distinct entities. The activity of monitoring a facility, system or process encompasses both measurement and analysis.

Data are raw numbers such as measurement results. Information is the result of applying some type of analysis to data.

Figure 1.11 illustrates the distinction between data and information for a production situation. In this case, the energy consumption and production of a melt furnace are routinely measured and recorded.

What refines performance data into management information is analysis – the key feature of the monitoring function. Management information provokes questions about performance that would not be evident in the raw data, and can lead to actions for the correction of problems or the optimisation of performance.

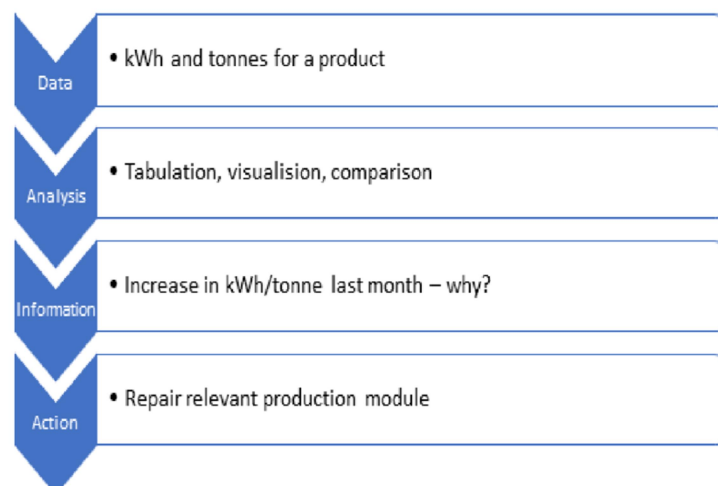

Figure 1.11: Data and information in production

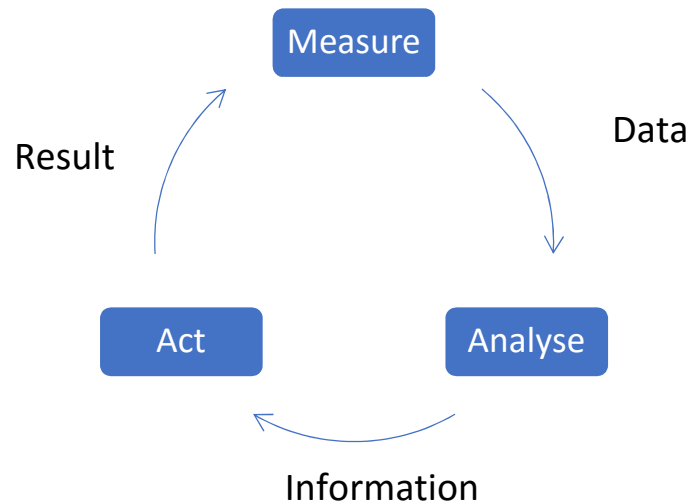

Figure 1.12: Measure–analyse–act cycle

Figure 1.11 suggests that the optimisation process (for any production situation) is linear; however, we prefer to think in terms of a continuous improvement cycle, as illustrated in Figure 1.12. Action in Figure 1.12 leads to a new round of monitoring and analysis to ensure that the change has been effective and is being sustained. New optimisation actions typically result, and so the cycle – measure–analyse–act – continues indefinitely, true to the intent of continuous improvement.

#### INFORMATION NEEDS FOR MONITORING AND TARGETING (M&T)

Energy monitoring is used to find out how much energy is costing the organisation, and to develop information that can serve as a basis for controlling consumption. This technique relies on quantitative – not just qualitative – data about energy use. There are qualitative indicators, to be sure: in many manufacturing processes, changes to energy inputs will bring about changes in product characteristics (e.g. the colour of a loaf of bread or the dryness of ink).

These qualitative indicators are sensitive and detectable, but not easily quantified and often dependent on subjective impression. Energy monitoring requires quantitative information, usually measured, such as:

- Energy billing data, including electricity demand and consumption, fuel consumption, and costs.
- Consumption measurements at some level (for example, the entire building, a production department, an individual energy-consuming system).
- Key independent variables that influence energy consumption, such as the production units in a manufacturing line/system.

In essence, energy monitoring is the technique of quantitatively relating actual consumption information to the critical independent variables.

#### INTERPRETING ENERGY CONSUMPTION DATA

Look at the energy consumption data in Table 1.15: *Thermal energy use data analysis* Thermal energy use data analysis and presented in Figure 1.10. These are two ways of presenting performance data, expressed as electrical energy consumption in kWh and specific energy consumption in kWh/tonne, over time. The form of presentation of these data is quite common

practice in industry; the data appear in a time series and the graph uses the energy use per tonne to indicate how energy use depends on the level of production.

Questions to be answered by monitoring implementation progress for plan:

- How many energy saving measures have been introduced?
- When did each take effect?
- How much energy has each measure saved?
- Are all the energy saving measures still working?
- Have any breakdowns been restored?
- How much energy will be required for a budgeted production of 120 tonnes a week in the next quarter?
- What further savings can be achieved?

Although all this information is available from the energy consumption data set, it can only be accessed through the kinds of analysis. To find out what has been happening in this glass melting furnace, we have to deal separately with two key questions:

- How does energy use vary with production?
- How does the relation between energy use and production change with time?

We are looking for a general procedure that can be used to relate energy consumption to whatever key parameters are determinant, usually production and/or weather. Data of this kind can be visualised in various ways that shed light on the situation.

#### » *Setting targets*<sup>1</sup>

##### TARGETS

- Are a statement of what management wishes to achieve
- Are determined from a position of knowledge
- Must challenge the organization but be achievable
- Convey management priorities
- Have two essential components:
  - An amount
  - A time

Targeting is a vital part of energy management as it encourages us to determine the lowest achievable levels of energy consumption. The Energy Manager needs to have a sense of appropriate targets for the plant as a guide for the measures that will be drafted.

Targeting is quite distinct from monitoring, although from the foregoing discussion we see that they are clearly related. Monitoring activities primarily attempt to maintain an existing level of efficiency. Targeting activities endeavour to determine achievable reductions in energy consumption. In some cases the target performance may be a period of previously demonstrated superior performance, as was the case in the example. However, targeting need not stop there.

As stated above, all targets have two basic elements:

- Measure of the level to which consumption can be reduced

---

<sup>1</sup> Energy-wise practice 6, NZ Energy Efficiency and Conservation Authority

- Time by which the reduction will be achieved.

To be worthwhile, both elements must be realistic. Targets related to those achievable by better, or more skilled, operators and management need to be distinguished from those that involve capital investments.

Targeting should become a dynamic process in which continued monitoring acts as an input for fine-tuning medium- and long-term targets. This is an element of a continuous improvement cycle.

**REVISION OF TARGETS**

After M&T has been in operation for a while, the preliminary target based on past performance will be easily attainable and should be reset. This can be done in a number of ways, including:

- Defining best historical performance as the new target;
- Basing a new target on an agreed set of actions designed to yield specific and quantifiable savings in both the incremental and the base loads;
- Setting a target for an arbitrary percentage of improvement based on current performance.

Although arbitrary, if properly chosen, this last target will be attainable. If the target exceeds the best historical performance, however, it will likely not be attainable and should therefore be avoided. This method is generally not recommended.

Whichever method is used, it is essential that personnel from each department be involved in the process of setting the targets and encouraged to provide their own input as to what is or is not realistic. Otherwise, key personnel may not “buy in” to the M&T approach and targets will not be achieved.

**PROCUREMENT OF ENERGY AUDITS**

Defining average costs for energy audits is not an easy task. The scope and level of detail of the energy audit can be a major cost driver. It is obvious that the costs for performing an audit at a company with different electrical and thermal processes will be higher than those for an audit in a small workshop or a bakery. Because an audit contract is given to an external consultant, the costs will range from a few hundred to thousands of USD.

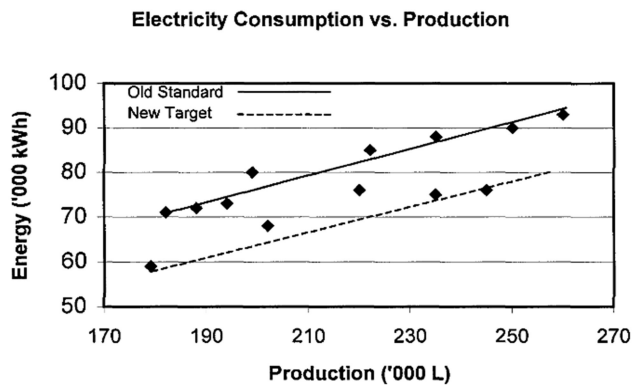

Figure 1.13: Target setting based on best historical performance

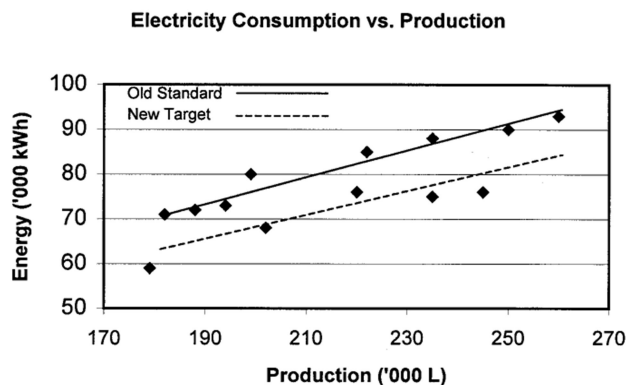

Figure 1.14: Target setting based on an arbitrary 10% reduction

All prices for energy audits of course relate to the time required to perform the audit and the consultant fees charged by the auditor. While the consultant fee is a factor of national income level, auditor qualification and experience, market competitiveness and other commercial factors (taxes, cost of living), what is generally open to discussion is the time required to complete the audit.

In theory, the timeframe depends on the company characteristics and the type of audit required (buildings, industrial processes or transport), as well as on the size of the organisation to be audited and its energy intensity. In practice, many other parameters influence the hours required by the auditors and, therefore, the typical audit prices.

Auditors need to work with real energy consumption data and company characteristics. Often they have to “hunt down” the necessary data, ensure its veracity or even obtain special measurements when information is lacking. The availability of correct company information is therefore a significant cost factor for energy audits.

Establishing criteria for cost-effectiveness prior to conducting the audit can help limit the scope to pursuing only viable projects.

Prices as well depend on:

- Level of the energy audit (Level I to III)
- Extent of available documentation and energy data
- Extent of the staff members’ familiarity with energy aspects
- Size of the facility
- Type of business
- Scope of assessment
- Equipment and technology – age of technology and equipment affects that amount of energy being consumed
- Building conditions – integrity of walls, ceilings, and insulation
- Layout of equipment – organisation of technology in isolated areas leads to concentrations of energy
- Reporting requirements

If there is already a capital improvement plan to replace ageing, inefficient machinery or to complete a major overhaul of your building’s lighting system, a Level III energy audit could direct the capital investment in the most cost-effective way and ensure that energy savings are maximised. Note that ISO 50002 does not require a certain audit level to be applied. The decision is left to the company and has to be discussed with the external auditor.

In general, auditing one big installation typically takes less time than auditing several smaller installations. The total cost of the energy audit for a large installation will of course be higher than for smaller sites. When expressed as cost per unit of occupied area or per unit of energy consumption, however, the costs will generally be lower.

Capital improvement and O&M budgets are key funding sources for energy audits. In some cases, the cost of an energy audit can be seen as a temporary investment rather than a cost, due to the payback from implementing no-cost or low-cost energy savings measures recommended during the energy audit.



After the Energy Auditor has assessed the situation, estimated time requirements, set his/her daily fee and furnished a quote, a plausibility check can be done. **See sample contract for auditor services and sample tender at Annex 6 and 7 respectively.**

*Example 25:* A company has an annual turnover of USD 100 million, and spends 1% on energy, i.e. USD 1 million per year. Based on the information gathered so far, it is safe to assume an energy savings of roughly 5%. That would be 2% of USD 1 million = 20,000 USD/year. Depending on the company's energy strategy and the organisation's economic setting, management can decide whether or not an energy audit that costs for example USD 15,000 sounds viable for the organisation.

### DEFINING THE ENERGY AUDIT FROM PRELIMINARY TO DETAILED AUDIT

There is not a single agreed upon set of definitions for the various levels of facility and system energy audits. In this course, we use the terms **preliminary audit** and **detailed audit** to refer to the level of detail with which the audit is concerned. Level of detail is the first significant audit qualifier. The second significant qualifier is its physical extent or scope. By physical extent or scope we mean the definition of the system being audited in terms of the number of its subsystems and components.

- **Level I** – The **preliminary audit** starts at a relatively high level in the structure of energy-consuming systems – perhaps the entire site or facility – and addresses a level of detail that permits at minimum the identification of plant areas that may potentially yield energy management opportunities; preliminary audits have a broad scope and lower level of detail.
- **Level II** – The **energy survey & analysis** starts with the findings of the Level I audit and evaluates the industrial energy systems in detail to define a variety of potential energy-efficiency improvements. It involves a detailed analysis of energy consumption to quantify base loads, seasonal variation, and effective energy costs.
- **Level III** – The **detailed audit** begins where the preliminary audit ends and works through an analysis of greater levels of detail; the focus of a detailed audit might be the entire plant if that is warranted by the findings of the initial walk-through, a specific energy-consuming system such as plant lighting, or an individual piece of equipment such as a boiler (this level should also include energy modelling and simulation).

Generally, as the level of detail of the audit increases, the scope or physical extent decreases. The opposite is also true; if the extent were increased, the level of detail of the analysis would tend to decrease.

The purpose of the audit template is to help ensure that nothing is lost in the data collection and analysis process, and that a logical, systematic approach is employed in the audit.

#### » *Practical auditing method – 13 steps*

The methodology described in this and the subsequent sections is adapted from a similar approach described in the *Industrial energy auditing guidebook*, currently in preparation for Natural Resources Canada. The audit mandate and audit scope templates are taken from NRCan's previous Energy Auditing Guide, now out of print.

The energy audit is a systematic assessment of current energy use practices, from the point of purchase to the end use. Just as a financial audit does for dollars, the energy audit identifies in quantitative terms:



- How and where energy enters the facility, department, system or piece of equipment;
- Where it goes and how it is used;
- Any variances between inputs and uses;
- How it can be used more effectively or efficiently.

The first two key steps in the audit are:

- **Initial client meeting:** While the Energy Manager will undoubtedly have numerous meetings with client representatives, it is especially important that various issues be addressed at the front end of the process.
- **Historical data analysis:** There is a great deal about the energy performance of the plant that the Energy Manager can discover through the analysis of historical energy consumption patterns.

After the initial client meetings and historical data analysis, the main steps include:

- **Walk-through inspection:** To assess the general level of repair, housekeeping, and operational practices that have a bearing on energy efficiency and to flag situations that merit further assessment as the audit is implemented; walk-through inspections will also be carried out to verify the findings of other analysis steps, as indicated in the flow chart.
- **Energy consumption and cost analysis:** Collect, organise, summarise and analyse historical energy billings and the applicable tariffs.
- **Energy performance comparison:** Determine energy use indicators and compare them internally among periods, comparable facilities in your portfolio, comparable systems; or compare indicators externally to good practice measures within your industry.
- **Audit mandate:** Secure commitment from management and define expectations and outcomes of the detailed audit.
- **Audit scope:** Define the energy-consuming system to be audited.
- **Detailed site inspection:** While many site inspections may take place, they serve the purpose of collecting more detailed energy use information and identifying energy management opportunities (EMOs) for specific energy-consuming systems.
- **Energy use pattern profiles:** Determine the time relationships of energy use, as in the electricity demand profile.
- **Energy use inventory:** Prepare a list of all energy-consuming loads in the audit area, and quantify their consumption and demand characteristics.
- **Energy management opportunities:** Include operational and technological measures to reduce energy waste.
- **Benefit assessment:** Quantify the level of energy and cost savings, along with any co-benefits.
- **Action report:** Report the audit findings and communicate as required for implementation.

Each step involves a number of tasks. As suggested by the flow chart, several of the steps may result in the identification of potential EMOs.

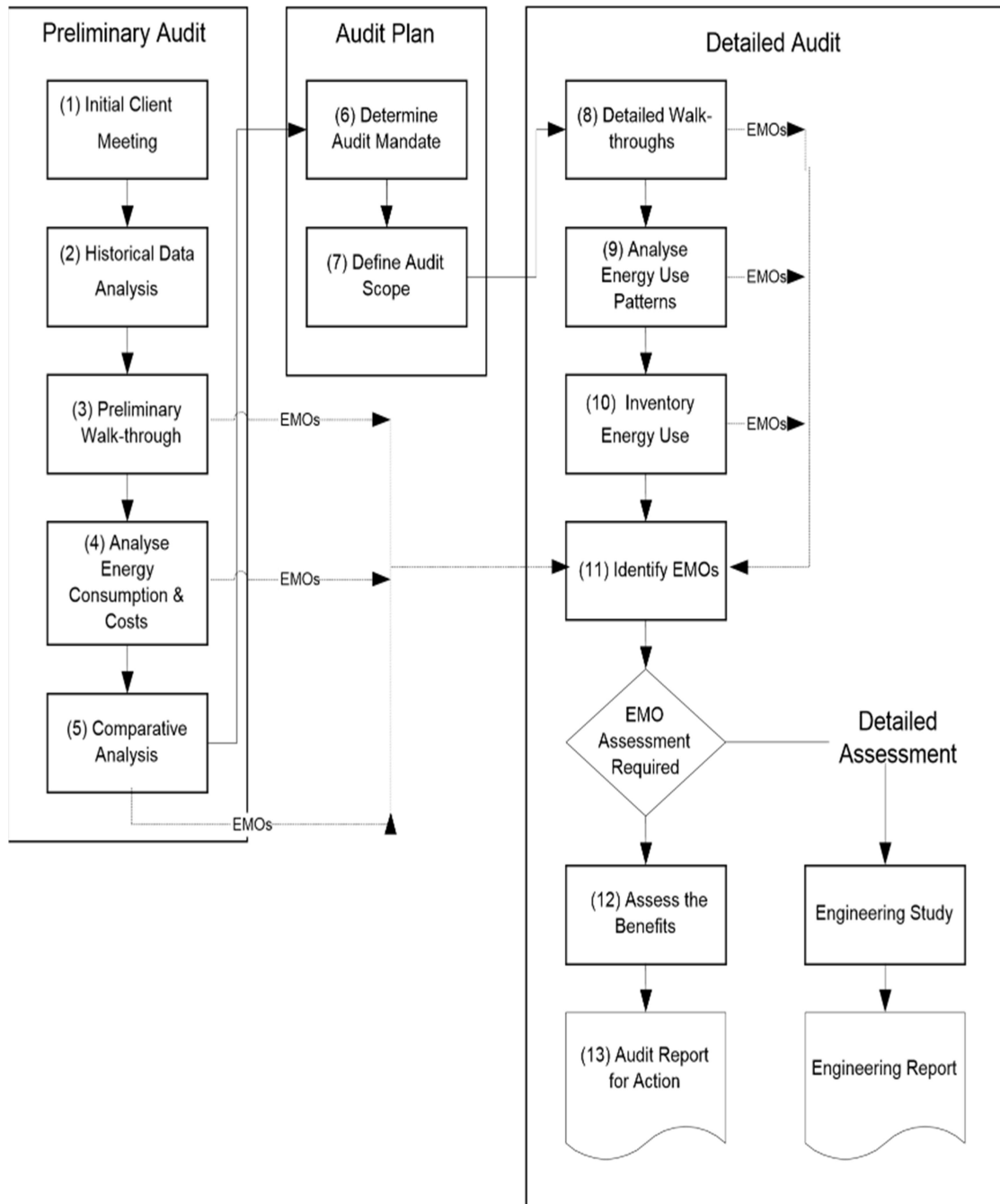

**Figure 1.15: Audit process flow chart** – Courtesy: Energy savings toolbox – An energy audit manual and tool - Natural Resources Canada, 2011. Reproduced with the permission of the Department of Natural Resources, 2016<sup>1</sup>

» **Final steps**

The audit may identify a wide range of potential EMOs. The assessment of some EMOs may be beyond the scope of the audit and require a more detailed engineering study. Other EMOs will not require further study and the savings will likely be significant and rapid; in these cases immediate implementation will be the logical course of action.

<sup>1</sup> Natural Resources Canada [www.nrcan.gc.ca/energy/efficiency/industry/cipec/5161](http://www.nrcan.gc.ca/energy/efficiency/industry/cipec/5161) – accessed March 30, 2017

## 1.7. SOFTWARE TOOLS FOR ENERGY MANAGEMENT

Below is a list of software tools that Energy Managers and Energy Auditors alike may find useful for carrying out their work.

### 1. RETScreen • [www.nrcan.gc.ca/energy/software-tools/7465](http://www.nrcan.gc.ca/energy/software-tools/7465)

**Description** RETScreen is a clean energy management software system for energy efficiency, renewable energy and cogeneration project feasibility analysis as well as ongoing energy performance analysis. The newest RETScreen “Expert” Edition (August 2016) is an advanced premium version of the previous “Suite” edition.

RETScreen is for professionals and decision-makers to rapidly identify assess and optimize the technical and financial viability of potential clean energy projects. This decision intelligence software platform also allows managers to easily measure and verify the actual performance of their facilities and helps find additional energy savings/production opportunities. As of October 2016, the RETScreen software had more than 490,000 users in 222 countries worldwide.

RETScreen Expert is available for download free-of-charge in viewer mode. Viewer mode will be sufficient for most energy analysis needs of most users. The full functionality of RETScreen Expert (including the ability to save, print and export files) is available in Professional mode by purchasing a renewable 12-month subscription, currently priced at CAD 869 per subscribing computer (plus applicable taxes) and charged on a cost recovery basis. The older version of the software, RETScreen Suite, is made available free-of-charge.

<b>Relevance</b>	This tool is also relevant for an Energy Auditor:			Y	Calculator:	Y
<b>Accessibility</b>	Online:	Y	Registration:	–	Download:	Y
					Charge:	Y

**Additional downloads** RETScreen user manual [http://publications.gc.ca/collections/collection\\_2008/nrcan/M39-115-2005E.pdf](http://publications.gc.ca/collections/collection_2008/nrcan/M39-115-2005E.pdf)  
 RETScreen® Plus Software Tutorial of the NASA  
<https://ntrs.nasa.gov/archive/nasa/casi.ntrs.nasa.gov/20150000447.pdf>

- Additional webpages**
- 90 Minute video tutorial how to use RETScreen for financial analysis. [www.youtube.com/watch?v=nX8JN0xkq5A](http://www.youtube.com/watch?v=nX8JN0xkq5A)
  - 55 Minute introduction to the RETScreen energy efficiency module. [www.youtube.com/watch?v=Gxf6h-MqbbM](http://www.youtube.com/watch?v=Gxf6h-MqbbM)
  - EnergyStar webpage of the USA about efficient gadgets, technology and processes. [www.energystar.gov/](http://www.energystar.gov/)
  - Energy Star portfolio manager for energy efficiency in any building. [www.energystar.gov/building](http://www.energystar.gov/building)
  - EnergyStar webpage of the European Union (EU) similar to the USA webpage [www.eu-energystar.org/](http://www.eu-energystar.org/)
  - Energy Star webpage for industrial products energy savings of 13 industries. [www.energystar.gov/buildings/industrial-energy-efficiency-resources-state-utility-programs](http://www.energystar.gov/buildings/industrial-energy-efficiency-resources-state-utility-programs)

### 2. International Energy Agency • [www.iea.org/statistics/resources/unitconverter/](http://www.iea.org/statistics/resources/unitconverter/)

**Description** An online calculator of the International Energy Agency in Paris, the OECD and EuroStat for conversion of energy, mass or volume units. Choose units, type number into one of the input boxes and click on the convert button.

<b>Relevance</b>	This tool is also relevant for an Energy Auditor:			Y	Calculator:	Y
<b>Accessibility</b>	Online:	Y	Registration:	–	Download:	–
					Charge:	–

**Additional downloads** [www.iea.org/publications/freepublications/publication/statistics\\_manual.pdf](http://www.iea.org/publications/freepublications/publication/statistics_manual.pdf)  
 Also from IEA the excellent 195 page manual “Energy statistics manual”, suitable for training of EA and EM professionals. Content: Fundamentals, electricity and heat, natural, gas, oil, solid fossil fuels and manufactured gases, renewables and waste, energy balance, fuel conversion and energy production processes, fuel characteristics, units and conversion equivalents, glossary with definition of units and list of abbreviations.

<b>Additional webpages</b>	Universal unit convertor www.unitconverters.net
<b>3. SinaSave</b> • <a href="http://www.industry.siemens.com/drives/global/en/engineering-commissioning-software/sinasave/pages/default.aspx">www.industry.siemens.com/drives/global/en/engineering-commissioning-software/sinasave/pages/default.aspx</a>	
<b>Description</b>	SinaSave determines the energy saving potential and payback times based on a particular application conditions. The tool offers a wide range of comparison options of various control modes and product combinations for drive systems for pump and fan applications. These are then graphically shown with their components as well as the most important results, for instance, the system and power losses per EN 50598. SinaSave supports an Energy Auditor as well as the procurement officer or Energy Manager of a firm. The tool is especially helpful in comparing the benefit /cost of various motor – blower or pump configurations.
<b>Relevance</b>	This tool is also relevant for Energy Auditors: <b>Y</b> Calculator: <b>Y</b>
<b>Accessibility</b>	Online: <b>Y</b> Registration: <b>Y</b> Download: <b>Y</b> Charge: <b>–</b>
<b>Additional downloads</b>	Energy efficiency legislation and standards: <a href="http://www.industry.siemens.com/topics/global/en/energy-efficient-production/legislation-and-standards/Pages/legislation-and-standards.aspx">www.industry.siemens.com/topics/global/en/energy-efficient-production/legislation-and-standards/Pages/legislation-and-standards.aspx</a>
<b>Additional webpages</b>	Mobile application to compare fixed or variable speed motor operation based on different IE classifications (IE1, IE2, IE3 and IE4) to select the most cost effective motor considering individual operating time and motor loads. In the variable speed operation module the most cost effective drive system can be determined based on a pump application with individual load profiles. The App also offers an overview of local minimum efficiency requirements for induction motors (so called MEPS – Minimum Efficiency Performance Standards) for selected countries. <a href="http://w3.siemens.com/topics/global/en/industry/future-of-manufacturing/industry-apps/simotics-ee-comparator/Pages/simotics-ee-comparator.aspx">http://w3.siemens.com/topics/global/en/industry/future-of-manufacturing/industry-apps/simotics-ee-comparator/Pages/simotics-ee-comparator.aspx</a>
<b>4. Loan payback calculator</b> • <a href="http://www.thecalculatorsite.com/finance/calculators/loancalculator.php">www.thecalculatorsite.com/finance/calculators/loancalculator.php</a>	
<b>Description</b>	Loan payback calculator with additional features such as initial charges and extra fees. It presents amortization schedule based on total equal monthly or annual instalments. The website provides the equations as well as additional explanations and definition’s common for loan applications. Allows balloon payments at the end of the term
<b>Relevance</b>	This tool is also relevant for an Energy Auditor: <b>Y</b> Calculator: <b>Y</b>
<b>Accessibility</b>	Online: <b>Y</b> Registration: <b>–</b> Download: <b>–</b> Charge: <b>–</b>
<b>Additional downloads</b>	A complete set of lecture series of the fundamentals of loans and borrowing, annuities, interest rates and time value of money. Many practical examples and complete set of equations. Replace “X” by 1, 2, 3, 4 and 5 <a href="http://mysmu.edu/faculty/yktse/FMA/S_FMA_X.pdf">http://mysmu.edu/faculty/yktse/FMA/S_FMA_X.pdf</a> Brief practical introduction about long-term loan repayment methods: <a href="http://extension.colostate.edu/docs/pubs/farmmgmt/03757.pdf">http://extension.colostate.edu/docs/pubs/farmmgmt/03757.pdf</a>
<b>Additional webpages</b>	Calculator that allows extra charges and shows amortization schedule <a href="http://www.bankrate.com/calculators/mortgages/loan-calculator.aspx">www.bankrate.com/calculators/mortgages/loan-calculator.aspx</a>
<b>5. National RE Laboratory</b> • <a href="http://www.nrel.gov/analysis/tech_lcoe.html">www.nrel.gov/analysis/tech_lcoe.html</a>	
<b>Description</b>	This levelised cost of energy (LCOE) calculator provides a simple calculator for both utility-scale and distributed generation (DG) renewable energy technologies that compares the combination of capital costs, operations and maintenance (O&M), performance, and fuel costs. Fossil fuel based generation cost can also be calculated. Note that this does not include financing issues, discount issues, future replacement or degradation costs. Each of these would need to be included for a thorough analysis. To estimate simple cost of energy, use the slider controls or enter values directly to adjust the values. The calculator will return the LCOE expressed in cents per kilowatt-hour (kWh).
<b>Relevance</b>	This tool is also relevant for an Energy Auditor: <b>Y</b> Calculator: <b>Y</b>
<b>Accessibility</b>	Online: <b>Y</b> Registration: <b>–</b> Download: <b>–</b> Charge: <b>–</b>
<b>Additional</b>	The underlying calculation methodologies and equations are explained at

<b>downloads</b>	<p><a href="http://www.nrel.gov/analysis/tech_lcoe_documentation.html">www.nrel.gov/analysis/tech_lcoe_documentation.html</a></p> <p>A manual (1993) for the economic evaluation of energy efficiency and renewable energy technologies is provided at: <a href="http://www.nrel.gov/docs/legosti/old/5173.pdf">www.nrel.gov/docs/legosti/old/5173.pdf</a></p>
<b>Additional webpages</b>	<p><a href="http://www.energy.gov/sites/prod/files/2015/08/f25/LCOE.pdf">www.energy.gov/sites/prod/files/2015/08/f25/LCOE.pdf</a> Compares the NREL model with the more sophisticated CREST models of USA Department of energy</p> <p><a href="https://financere.nrel.gov/finance/content/crest-cost-energy-models">https://financere.nrel.gov/finance/content/crest-cost-energy-models</a></p>

**6. Department of Energy, USA • <http://energy.gov/eere/amo/software-tools>**

<b>Description</b>	<p>The Advanced Manufacturing Office (AMO) of the DoE offers tools to help Energy Managers to identify and increase industrial energy efficiency at the plant-level and in specific systems. Step-by-step ways are provided to identify opportunities, monitor progress, and improve efficiency in any facility. Some tools help facilities implement an energy management system and prepare to become ISO 50001 and superior energy performance certified. The tools are divided into two major subject areas: (i) Managing a plant’s energy use and (ii) managing and optimizing a plant’s systems and equipment for steam, process heating, compressed air, pumps and fans.</p>			
<b>Relevance</b>	This tool is also relevant for an Energy Auditor:		Y	Calculator: Y
<b>Accessibility</b>	Online: Y	Registration: Y	Download: Y	Charge: –
<b>Additional downloads</b>	<ul style="list-style-type: none"> <li>• The DoOE (USA) YouTube videos about energy efficiency and renewable energy. <a href="https://www.youtube.com/energygov">https://www.youtube.com/energygov</a> (1207+ videos also about energy efficiency)</li> <li>• Steam system tool: <a href="https://www.youtube.com/watch?v=xibGrIf0kHQ">https://www.youtube.com/watch?v=xibGrIf0kHQ</a></li> <li>• DoE webinars 2008- 2016 <a href="http://energy.gov/eere/fuelcells/webinars">http://energy.gov/eere/fuelcells/webinars</a></li> </ul>			
<b>Additional webpages</b>	<ul style="list-style-type: none"> <li>• eGuide: <a href="https://ecenter.ee.doe.gov/_layouts/ecenter/ppc.eguide/home.aspx">https://ecenter.ee.doe.gov/_layouts/ecenter/ppc.eguide/home.aspx</a></li> <li>• eGuideLite: <a href="https://ecenter.ee.doe.gov/EM/SSPM/Pages/HowToExtract.aspx">https://ecenter.ee.doe.gov/EM/SSPM/Pages/HowToExtract.aspx</a></li> <li>• All other tools: <a href="https://ecenter.ee.doe.gov/EM/tools/Pages/HomeTools.aspx">https://ecenter.ee.doe.gov/EM/tools/Pages/HomeTools.aspx</a></li> <li>• Webinar about free Energy Manager tools. <a href="http://www.youtube.com/watch?v=Je60M1FB070">www.youtube.com/watch?v=Je60M1FB070</a></li> <li>• Schneider - Electric about Energy Management mMade eEasy. <a href="https://www.youtube.com/watch?v=PYdkKuQiAEs">https://www.youtube.com/watch?v=PYdkKuQiAEs</a></li> <li>• Schneider Electric about Energy Management made easy. <a href="http://www.youtube.com/watch?v=PYdkKuQiAEs">www.youtube.com/watch?v=PYdkKuQiAEs</a></li> <li>• An introduction to the CEM program. <a href="http://www.youtube.com/watch?v=sn3eDAqHWrQ">www.youtube.com/watch?v=sn3eDAqHWrQ</a></li> </ul>			

**7. Schneider Electric • [www.schneideruniversities.com/energy-university/](http://www.schneideruniversities.com/energy-university/)**

<b>Description</b>	<p>Distant learning energy university. 102 energy efficiency courses are offered for free. Self-paced modules that take less than an hour, available 24 hours a day. Tailored course selections or choose targeted learning paths by energy topic, including data centres, energy and infrastructure, industry, health care, buildings and residential. Professional Energy Manager (PEM) exam costs USD 400 and is administrated by the Energy Management Diploma Programme provided by North Carolina State University, USA.</p>			
<b>Relevance</b>	This tool is also relevant for an Energy Auditor:		Y	Calculator: –
<b>Accessibility</b>	Online: Y	Registration: Y	Download: Y	Charge: Y
<b>Additional downloads</b>	<p>Required course list for the PEM exam</p> <p><a href="http://www2.schneider-electric.com/documents/training/energy-university/Energy_University_PEM_Exam_Course_List.pdf">www2.schneider-electric.com/documents/training/energy-university/Energy_University_PEM_Exam_Course_List.pdf</a></p>			
<b>Additional webpages</b>	<p>Catalogue of 102 courses offered for Energy Manager and Energy Auditors</p> <p><a href="http://www.schneideruniversities.com/energy-university//catalog">www.schneideruniversities.com/energy-university//catalog</a></p> <p><a href="http://www.ncsu.edu/mckimmon/cpe/brochures/pdf/em.pdf">www.ncsu.edu/mckimmon/cpe/brochures/pdf/em.pdf</a> (PEM)</p>			

## 2. NORMS, CODES AND STANDARDS

### About this module

For their future success as Energy Auditors, trainees must possess in-depth knowledge about the ISO 50001 and ISO 50002 norms which can be applied when carrying out their tasks. This module introduces trainees to the ISO energy management system norm.

### Learning outcomes

At the end of this module, the participant is able to

- Explain the characteristics of a management system in general and the ISO 50001 management system in particular
- Explain the steps for implementation of the ISO 50001 system
- Explain the audit as the central element of the ISO 50001 system

### 2.1. INTRODUCTION TO ENERGY MANAGEMENT AND AUDITING ACCORDING TO ISO 50001 AND ISO 50002

The international norm ISO 50001 specifies the requirements for establishing, implementing, maintaining and improving an **energy management system (EnMS)**, whose purpose is to enable an organisation to follow a systematic approach to continually improve its energy performance, including the aspects of energy efficiency, energy security, energy use and consumption.

An organisation in the sense of ISO is any commercial enterprise, as well as private houses, hospitals or offices. The norm aims to help organisations continually reduce their energy use, and therefore their energy costs and their greenhouse gas emissions.

#### ABOUT ISO 50001

ISO 50001 was released by the International Organization for Standardization (ISO) in June 2011, and is suitable for any organisation – whatever its size, sector or geographical location.

ISO is an independent, non-governmental organisation, the members of which are the standards organisations of the 164 member countries. It is the world's largest developer of **voluntary** international standards and facilitates world trade by providing common standards between nations. Nearly twenty thousand ISO standards have been defined, covering everything from manufactured products and technology to food safety, agriculture and healthcare.



Figure 2.1: ISO 50001 energy management logo  
– Source: [www.batesenergy.com](http://www.batesenergy.com)

**ISO 50001**  
is the new standard for  
implementing a robust  
**Energy Management  
System (EnMS).**

It establishes an  
international framework for  
industrial plants or entire  
companies to manage all  
aspects of energy,  
including procurement  
and use.



Figure 2.2: Introduction to EnMS – Source:  
[www.slideshare.net](http://www.slideshare.net)



Many countries have meanwhile adopted various ISO standards into their own standard systems. The Standards Organisation of Nigeria (SON) adopted ISO 50001 as NIS ISO/IEC 50001:2011 without any changes.

The structure of ISO 50001 is designed according to other ISO management system standards, in particular ISO 9001 (quality management systems) and ISO 14001 (environmental management systems). Since all three management systems are based on the PDCA cycle, ISO 50001 can be easily integrated into these systems.

### ISO MANAGEMENT SYSTEMS

Before going deeper into the ISO 50001 energy management system, we will start by clearing up a common misunderstanding.

**Note:** ISO 50001 is a management system and *not* a guideline on how to reduce the energy consumption of an enterprise, office, hospital, etc. ISO 50001 provides neither technical measures nor standards on how to reduce energy consumption to comply with specific benchmarks.

ISO 50001 is a voluntary *management standard* which helps you to implement a management system designed to reduce energy consumption and costs.

#### » The ISO “family”: ISO 9001, 14001 and 50001

The **ISO 9000** et seqq. standard series mainly applies to quality management systems (QMS). It is likewise possible to integrate an environmental management system (EMS) into a QMS.

The structure of the environmental management standard **ISO 14000** et seqq. matches the structure of the quality management standard ISO 9000 et seqq. and vice versa. All three management systems are therefore compatible. Many companies in the US or in Europe have been certified by all three management systems.

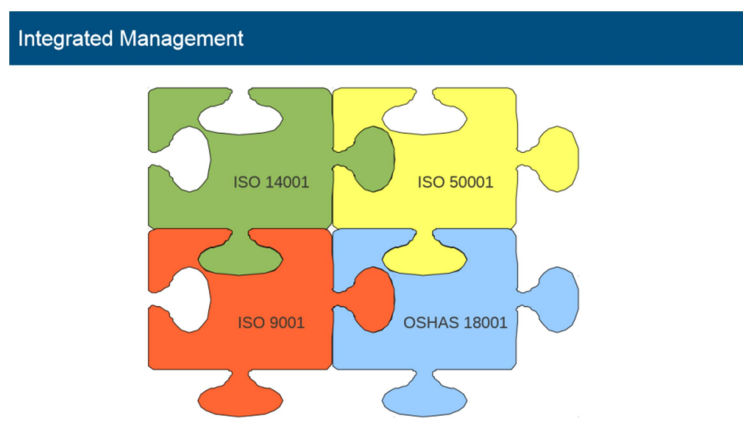

Figure 2.3: The ISO family

As can be seen in the graphic below, an additional standard known as the **European OSHAS** or Occupational Health and Safety Assessment Series closely approximates ISO 9001 and 14001 in terms of its structure and is slated for imminent inclusion in the ISO “family” as ISO 45001.

#### » ISO 50001: Energy management and energy management systems

Energy management includes all the measures that are planned and implemented to minimise energy consumption for a given activity. Energy management influences organisational and technical procedures, as well as behavioural patterns, in order to reduce the total operational energy consumption (thus also the energy required for production) for the cost-effective use of basic and auxiliary materials and the continuous improvement of an organisation’s overall; energy efficiency.



An energy management system (EnMS) systematically records the energy flows and serves as a basis mainly for investments in energy efficiency improvements. A functioning EnMS helps a company to comply with the commitments in its energy policy and to continuously and systematically improve its energy performance.

Globally, the ISO 50001 is the first standard for EnMS and presents a systematic pathway for implementation. This handbook refers to the ISO 50001 almost exclusively. But it should be noted that EnMS can be implemented without reference to this standard. In fact it is estimated that as of 2016, more than a million enterprises have done – or are still doing – successful EnMS and are investing in EMOs without applying ISO norms while not more than 30,000 (less than 3%) are following ISO 5000X.

An EnMS encompasses all elements of an organisation that are necessary for creating an energy policy, as well as defining and achieving strategic objectives. It thus includes the organisational and informational structures required for implementing energy management, including all necessary resources. It formulates and implements the energy policy (together with strategic and operational objectives and the action plan), planning, introduction and operation, monitoring and measurement, control and correction, internal audits, as well as a regular management review.

#### **ADVANTAGES OF AN ENERGY MANAGEMENT SYSTEM**

The introduction of an EnMS essentially requires the systematisation of energy-saving methods. In the long term, this results in measurable and quantifiable estimates of energy savings and cost-related improvements, as well as enhanced process efficiency. At the macro-level, it vastly contributes to improving the environmental situation. There are various advantages to introducing an EnMS. The main reasons are discussed below.

##### ***Cost reduction***

High energy costs reduce overall profit – in almost every company, there is always some potential for reducing energy consumption. An EnMS helps reduce the risk that energy expenses unexpectedly increase or supply shortages occur that could seriously affect productivity, or even threaten the continuous operation of an organisation. By introducing an EnMS, you can save 10 to 30% of your energy costs in the first few years after implementation. This can be done by systematically identifying the weak points in your energy consumption and addressing them with basic measures. Investments in energy-efficient technologies are also worthwhile: more efficient compressed air and pump systems, as well as ventilation systems, refrigeration and materials handling technology, will result in a 5 to 50% reduction in power consumption with an average payback time of less than two years.

##### ***Environmental protection***

Climate change is already one of the main causes of natural catastrophes like floods and droughts. Even today, the consequences for humans and the environment are considerable. While climate change takes place globally, climate protection must occur locally. An efficient energy management system is therefore an important element as it can contribute considerably to reducing greenhouse gas emissions.

##### ***Sustainable management***

Resource efficiency in all areas, and particularly with respect to energy, is a much-discussed topic of our times. Fossil fuel reserves are limited. Those who continue to rely on these resources are not preparing themselves for the future. Efficient energy management, new ener-

gy concepts and innovative energy technologies are keys to succeeding in the market in the coming years and decades, as they will help reduce expenditures for critical and finite resources.

### *Improvement of public image*

By achieving an ISO 50001: 2011 certification, you can credibly show the public that your company is operating sensibly with respect to energy efficiency and is thus doing its part to protect the environment. Environmental requirements are an increasingly important factor in public proposals, including, among others, climate-friendly purchasing. Both from the perspective of the procurer and the supplier, an EnMS supports the calculation of CO<sub>2</sub> emissions reduction derived from energy savings accounting and carbonaceous fuel properties and enhances an organisation's green credentials.

#### » *Characteristics of ISO 50001*

ISO 50001:2011 specifies requirements for establishing, implementing, maintaining and improving an energy management system, whose purpose is to enable an organisation to follow a systematic approach to continually improve its energy performance, including the aspects of energy efficiency, energy use and consumption.

The norm specifies requirements applicable to energy use and consumption which include documentation and reporting, as well as design standards and procurement practices for equipment, systems, processes and personnel that contribute to energy performance.

It applies to all variables affecting energy performance that can be monitored and influenced by the organisation. ISO 50001:2011 does **not prescribe** specific energy performance criteria. It has been designed for independent use, but it can be aligned or integrated with other management systems.

ISO 50001 is applicable to any organisation wishing to ensure that it conforms to its stated energy policy and wishing to demonstrate this to others, such conformity being confirmed either by means of self-evaluation and self-declaration of conformity, or by an external certifying body.

The ISO 50001 standard, which was published in June 2011 and replaces the European EN 16001 standard, defines the first international standards for an energy management system. The preceding European standard EN 16001 already contributed to significant energy savings in European companies.

#### » *Justification of ISO 50001*

In times of increasing greenhouse effects, rising energy costs and the depletion of energy resources, costs for industrial and household energy consumption are becoming more and more difficult to calculate. This brings uncertainties for the future and for further planning in the economic sector. The ISO 50001 standard is a management system which can help to reduce energy consumption and costs, and therefore contribute to sustainability.

Energy management and energy efficiency are not just for big companies. Small businesses can also achieve sizable savings, because organisations both big and small, including offices, hospitals and apartment buildings, all use energy in various ways and there is ALWAYS potential for improvement, i.e. reduced consumption.

Since the resulting energy, environmental and operational savings are so great, it is no longer a question of whether a business can afford to upgrade, but whether it can afford not to.

Systematic energy management is used worldwide in many companies. Good energy management pinpoints potential areas for energy savings. Exploiting such a potential reduces administrative costs and increases an organisation's competitiveness.

All organisations – whether big or small, simple or complex, for-profit or non-profit – have some kind of management system. This can be formal or informal but all systematic internal rules regarding responsibilities and procedures in a company should be considered and integrated into the energy management system.

A management system should ensure that all significant objectives of the company are implemented in a systematic manner and can be assessed at every phase. Management systems which are used appropriately contribute to the improvement of the operational and organisational structure of a company, in accordance with the requirements of the market, customers, investors, society and nation. Management systems are based on organisational measures like establishing responsibilities, positions, operational procedures and monitoring systems. By defining accountability in action plans (who does what, by when?) and assessing the system objectively either through internal channels or, if necessary, by external auditors, it is possible to monitor whether the objectives are being achieved on time or, if documented, who or what is responsible for any deviations.

**2.2. THE PDCA CYCLE**

The ISO norms 9001, 14001 and 50001 are based on the same implementation structure, the PDCA cycle: plan-do-check-act (or adjust). PDCA is an iterative four-step management method used in business for the control and continual improvement of processes and products.

The individual steps of the PDCA cycle in energy management can be described as follows:



Figure 2.4: Consequences of increasing greenhouse effects – Source: www.slideshare.com

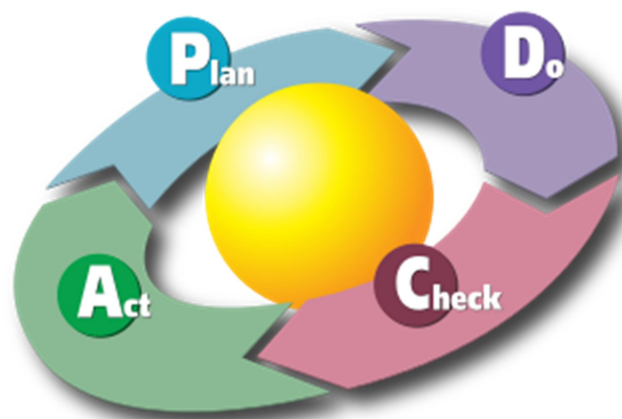

Figure 2.5: Plan-do-check-act cycle

## PDCA SYSTEM STEPS

### Plan

Establish the objectives and processes necessary to deliver results in accordance with the expected output (i.e. target or goals). By establishing output expectations, the completeness and accuracy of the specification is also a part of the desired improvement. When possible, start on a small scale to test possible effects. To summarise the components of this step: establish your energy-saving targets, determine the strategy, identify measures and responsibilities, provide the necessary resources and prepare your action plan.

### Do

Implement the plan, execute the process, and make your product. Collect data for charting and analysing your progress in the following steps (“CHECK” and “ACT”). Establish management structures to help maintain process continuity and undertake improvement measures (e.g. more efficient technologies/procedures).

### Check

Study the actual results (measured and collected in “DO” above) and compare them against the expected results (targets or goals from “PLAN”) to ascertain any differences. Look for deviations from the plan and also check the plan’s suitability and completeness for execution (“DO”). Charting data can make it much easier to spot trends over several PDCA cycles and convert collected data into information. Information is what you need for the next step (“ACT”).

Review the level of target achievement and the effectiveness of the EnMS, collect new ideas by performing energy audits. Consider consulting an external expert (also examine and consider deviations as well as corrective and preventive actions).

### Act

If your CHECK shows that the PLAN implemented in DO does in fact improve on the prior standard (baseline), then it should become the new standard (baseline) for how the organisation should ACT going forward (new standards are enACTed). If the CHECK shows that the PLAN implemented in DO does not represent an improvement, then the existing standard (baseline) will remain in place. In either case, if the CHECK turned up an unexpected deviation (whether for the better or the worse), then there is further potential for learning... and that suggests additional PDCA cycles.

All steps and activities can take place in parallel; the decision to begin a step or an activity depends on the conditions in the respective company.

When compared to selective measures (ad-hoc energy management), continuous application of this process clearly reduces the energy-related costs of a company.

Referring back to the main components we find the p/d/c/a elements described at the following points in ISO 50001 (sections numbered as in ISO 50001):

Table 2.1: P/D/C/A described in some sections of ISO 50001

Chapter in ISO 50001	p/d/c/a
4.1. General requirements	
4.2. Management responsibility	
4.3. Energy policy	

Chapter in ISO 50001	p/d/c/a
4.4. Energy action plan	Plan
4.5. Implementation and operation	Do
4.6. Performance audits/checking	Check
4.7. Management review	Act



Figure 2.6: PDCA cycle and content

**Example 1: Practical example (adapted)**

A medium-sized company called “Paper Recycling Miller Ltd” decided to introduce an EnMS to reduce energy costs. To implement the EnMS, a continuous, objectively assessable improvement process should be present in the structures of the company.

The head of the company initiated the process by including the objective of energy-efficient management in the company philosophy, appointing an Energy Manager and providing him with the corresponding resources and responsibilities (**Plan**). The manager was then responsible for coordinating the documentation of all energy-related processes in the company.

The company “Paper Recycling Miller Ltd” has already taken other approaches for an environmental management system. In the past, however, these approaches were not applied in a systematic manner, because only certain processes in the company were controlled and directed by the system. Nevertheless, there is some knowledge about management systems in the company. To reflect the continuous improvement process, management establishes a structure to introduce an EnMS that will make it possible to record and assess all energy flows in order to then identify savings potentials and implement measures which are technically viable, financially attractive and within the company’s overall means (**Do**).

The Energy Manager regularly assesses the results of the measures, sets new targets and compiles reports (**Check**).

The Energy Manager then implements newly defined targets and measures with the support of employees and an external energy advisor (**Act**).



» **Energy policy****DEFINITION OF AN ENERGY POLICY**

According to ISO 50001, the starting point for a functioning EnMS is the formulation of an energy policy for the company. The energy policy that needs to be documented in hard copy is a statement containing effective energy management objectives outlined by top management. The document is the first step in a structured energy management process.

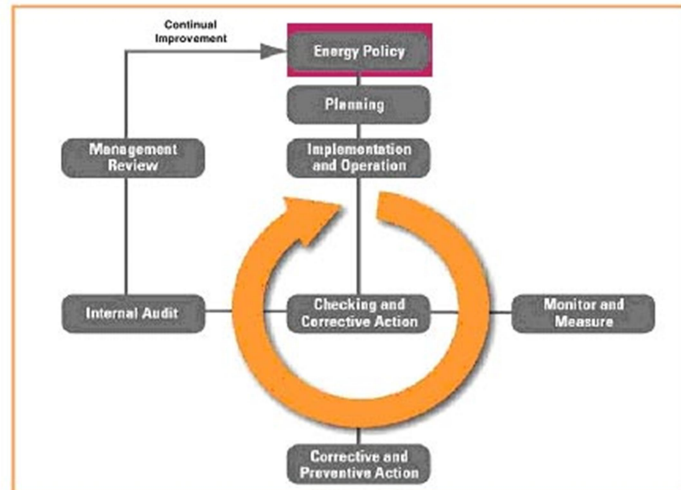

Figure 2.7: Energy policy in the management cycle – Source: [www.slideshare.net](http://www.slideshare.net)

The energy policy sets out energy-related guidelines, operating principles and long-term overall objectives for a company. It is used, over time, as a measurement for the effectiveness of energy management.

According to ISO 50001, a company's energy policy must contain the following points:

- The commitment of top management is to continuously increase the energy efficiency of the company, as well as to carefully handle energy, should be expressed.
- Obligation of management to provide all information and resources required for realising energy objectives and targets.
- Obligation to adhere to all legal obligations that affect the energy aspects of the company.
- Support for the purchase of energy-efficient products and services.

After developing and introducing an energy policy, its content should be communicated to all people working directly or indirectly for the company. The energy policy should also be regularly assessed and, if required, adapted to changing circumstances.

If there are already other policies in the company, such as an environmental or quality policy, then the energy policy can be integrated into that document. If the company operates in several locations, the energy policy can refer to activities at all sites or only to specific locations. Clearly define the system boundaries for the implementation of objectives.

When formulating your energy policy, ensure that it can be easily understood inside and outside of the company.

According to ISO 50001, it is not mandatory to make an energy policy publicly accessible. Such transparency is advisable, however, as it places your company in a positive light.

**ISO DEFINES ENERGY POLICY IMPLEMENTATION AS FOLLOWS**

(Enumeration follows ISO 15001)

### *Energy policy*

The energy policy states the organisation's commitment to achieving energy performance improvement.

Top management has defined the energy policy and ensures that it:

- a) Is appropriate to the nature and scale of the organisation's energy use and consumption;
- b) Includes a commitment to continual improvement in energy performance;
- c) Includes a commitment to ensure the availability of information and of necessary resources to achieve objectives and targets;
- d) Includes a commitment to comply with applicable legal requirements and other requirements to which the organisation subscribes related to its energy use, consumption and efficiency;
- e) Provides the framework for setting and reviewing energy objectives and targets;
- f) Supports the purchase of energy-efficient products and services, and design for energy performance improvement;
- g) Is documented and communicated at all levels within the organisation;

**An energy policy should, furthermore, be regularly reviewed in energy management team meetings and management review meetings, and updated as necessary.**

#### *Example 2: Energy policy of Repsol (mineral oil company)*

Repsol undertakes a commitment to make efficient use of energy at its facilities and during its activities, with the purpose of preserving natural resources, reducing atmospheric emissions and helping to mitigate the effects of climate change.

Management will lead and promote energy efficiency programs, ensuring that the organisation works in accordance with the principles established in this policy.

Repsol will establish objectives and targets in order to improve energy performance and reduce the relevant greenhouse gas emissions. In order to achieve them, management will ensure the availability of the necessary information and resources.

Repsol will continuously improve the use of energy resources at its facilities and during its activities throughout their entire life cycle, optimising the technology and design of processes as well as the operation of its facilities, and supporting the purchase of energy-efficient products and services.

Repsol will ensure compliance with the legal requirements in force and other energy-related requirements to which the organisation subscribes, including energy efficiency and the use and consumption of energy. The company will also encourage the adaptation of its operations and facilities to ensure compliance with any changes that may be made to the legal framework in force, and will establish common standards for the management of energy efficiency in all the areas and countries in which it operates.

In order to promote greater awareness among all stakeholders, Repsol will provide them with reliable and transparent information regarding its energy consumption, its corresponding greenhouse gas emissions and the improvement actions undertaken.

Repsol considers that "complying and ensuring compliance" with this policy is the responsibility of all individuals who take part in its activities.



## 2.3. THE PLAN/DO/CHECK/ACT PROCEDURE

### PLAN

#### » Energy plan

The energy plan is the most important part of the procedure. It forms the basis for all implementation steps from data collection to the actions. Errors and mistakes in the action plan will lead to non-compliance with the defined targets of the management system.

When introducing an EnMS, all relevant areas of energy consumption in the organisation should be reviewed and illustrated in a specific structure defined by the organisation. Savings potentials can be determined using the clear and understandable illustration of the consolidated data. This helps in defining short- and medium-term objectives. Additionally, the information gathered can be used for certification of the EnMS, as well as in communicating results inside and outside the company.

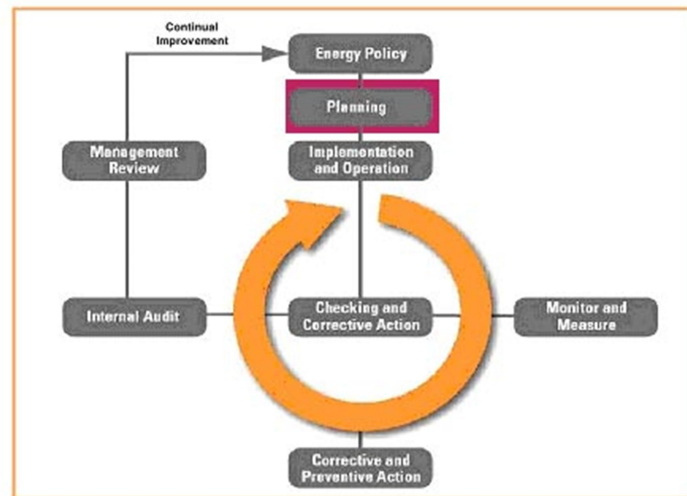

Figure 2.8: Planning within the management cycle

Steps to be followed during the planning stages:

- Identifying responsibilities
- Including legal obligations
- Reviewing the consumption, costs and production figures of energy
- Processing and documenting the collected data
- Defining energy objectives and targets
- Formulating an energy management programme and an action plan.

#### ENERGY PLANNING AS DEFINED BY ISO

##### *General*

The organisation has conducted and documented an energy planning process. Energy planning is consistent with the energy policy and leads to activities that continually improve energy performance as per the documented procedure.

Energy planning involves a review of the organisation's activities like engineering, production, maintenance, etc. that can affect energy performance.

##### *Legal and other requirements*

Procedures have been established and implemented:

- To identify applicable legal requirements and other requirements related to energy use, consumption and efficiency subscribed to by the plan/system,
- To verify that these requirements apply to the system's energy use, consumption and efficiency,

- To ensure that legal and other requirements are considered in establishing, implementing and maintaining the energy management system.

The legal and other requirements should be reviewed once every six months in management review meetings.

The information for legal requirements is updated and relevant information on legal and other requirements is communicated to the employees and relevant interested parties. Companies should establish and maintain a register of energy legislation.

#### » *Energy review aspects*

Organisations also need to develop and maintain an energy *review* system as per the documented procedure. Documentation should be provided for the methodology and criteria used to develop the energy review. Identifying significant energy use areas is an on-going process that determines the past, current and potential impacts of the activities, products, and services covering routine and non-routine actions, all activities covering job contractor work and all facilities at the workplace. The energy review should follow an established procedure that outlines the expected areas of influence which are subject to inspection. An evaluation procedure should also be established to determine significant energy use areas and set the EnMS objectives. Overall, the energy review system should be developed and relevant records maintained based on the points listed below.

Designate functional heads to analyse energy use and consumption based on measurements and other data:

- Identify current energy sources;
- Evaluate past and present energy use and consumption;

Identify areas of significant energy use based on the analysis of energy use and consumption considering:

- Facilities, equipment, systems, processes and personnel working for, or on behalf of, the organisation that significantly affect energy use and consumption;
- Other relevant variables affecting significant energy uses;
- Current energy performance of facilities, equipment, systems and processes related to identified significant energy uses;
- Future energy use and consumption (estimation);

For each area, the functional heads will identify, prioritise and record opportunities for improving energy performance. These management representatives will monitor the results as per the records. Opportunities are considered to improve existing energy sources such as the use of renewable energy or other alternative energy sources including waste energy.

#### » *Energy baseline*

With the help of the energy management team, the management representative (or Energy Manager) has to establish an energy baseline (or baselines) using the information in the initial energy review while considering a data period suitable to the organisation's energy use and consumption. Changes in energy performance are measured against the energy baseline(s) and discussed in the energy team review meeting.

An adjustment to the baseline is made in the case of one or more of the following:

- Energy performance indicators no longer reflect organisational energy use and consumption,
- There have been major changes to the process, operational patterns, or energy systems,
- According to a predetermined method as defined in the procedure.

The management representative is responsible for maintaining energy baseline records.

» **Energy performance indicators**

With the help of energy management team, the management representative will identify energy performance indicators (EnPI) appropriate for monitoring and measuring the system's energy performance. The methodology for determining and updating the EnPIs is established in the procedures and records are maintained. The EnPIs are regularly reviewed in energy management team review meetings and compared to the energy baseline as appropriate.

» **Energy objectives, energy targets and energy management action plans**

Energy objectives and targets for relevant functions, processes, facilities, and levels within the company are prepared, documented, and implemented as performance indicators based on the energy policy. Targets should be based on all parameters that decisively impact energy consumption. During their selection, management and staff should ensure the measurability of the respective parameters. Targets should be ambitious while also remaining realistic enough to be achieved within the allotted time period.

All such objectives and targets must be made measurable and consistent with the energy policy, including commitments to comply with the applicable legal framework and other requirements which form the basis for continual improvement. A realistic time frame for the achievement of the objectives and targets should also be defined.

The energy management action plan must be prepared, implemented, and maintained to ensure the achievement of all defined objectives and targets. The energy management action plan includes:

- Responsibilities for achieving objectives and targets at relevant functions and levels of staff/organisation,
- Methods/means and time frame for achieving objectives and targets.
- Statement of the method by which an improvement in energy performance shall be verified
- Statement of the method for verifying the results.

Here are a few starting points for developing targets and objectives:

- Production processes (e.g. efficient use of compressed air and condensate, switches and valves, automatic integrated systems)
- Motors and engines (e.g. increased usage of electronic controls, variable speed drives, integrated application programmes, frequency converters, highly-efficient electric motors)

- Ventilators, variable speed drives and ventilation (e.g. new devices/systems, use of natural ventilation)
- Demand management (e.g. load management, servo mechanism for peak load dismounting)
- Highly efficient combined heat and power (CHP plants)

Rough cost-benefit estimates may be helpful when identifying and selecting operational objectives. The selection can be done using a weighted scoring system, whereby the following aspects should be considered:

- Legal provisions,
- Industry standards,
- Implementation costs,
- Investment costs,
- Payback time and environmental benefits.

#### **REVIEW CONSUMPTION, COSTS AND PRODUCTION OF ENERGY**

Always remember: you can't manage what you don't measure! Measurement data can be obtained from the energy audit. Before measurements can be made, it is necessary to define certain elements known as **indicators**.

##### » *Energy performance indicators*

Industrial operations are generally complex, involving many sub-activities with a high level of variability both between similar operating sites and over time. Performance indicators that take this diversity into account are therefore essential for understanding and analysing energy performance. Improvements in energy performance require effort and actions at all organisational levels with indicators that are relevant and adapted to each level.

Indicators should be defined as precisely and accurately as possible, outlining both the scope and boundaries and identifying the applied metric. Indicators should preferably be in line with international reporting standards to allow for comparison and internal and external benchmarking. When evaluating energy efficiency based on indicators, care must be exercised to compare like categories. Indicator values will reflect energy efficiency achieved by operational enhancements and specific improvement projects, but the overall values will vary greatly depending on many factors.

#### **INDICATORS BASED ON OPERATIONAL DATA (LAGGING)**

Energy performance is commonly assessed with "lagging indicators" which are retrospective metrics based on actual operational data, reflecting the "was-is" situation of energy performance.

#### **OPERATIONAL LEVEL INDICATORS**

These indicators are typically relatively simple process functions calculated on a semi- or fully-continuous basis in order to measure and monitor energy usage over the short term, down to a single unit or facility.

Operational level indicators are commonly developed for each site and each processing entity according to the specific local situation (see also 4.5.5 of the ISO standard).

Care must be taken to account for different quality levels of either products or resources when assessing energy performance.

#### **SITE LEVEL INDICATORS**

These indicators are based on aggregated data from the site and are commonly calculated on a quarterly or yearly basis. They serve to measure and monitor the energy efficiency of the site over time and/or against peers.

Absolute energy consumption (in units of energy per year) may be used for management and/or financial reporting purposes but is of little interest as an energy performance indicator because it does not refer to the corresponding level of activity.

Specific energy consumption (expressed in units of energy per processed production unit) is a commonly used indicator. It is often referred to as energy intensity. This is, however, of limited use for the comparison or benchmarking of facilities of different complexity or varying asset types (production area, offices, storage, etc.).

Taking the oil and gas industry as an example, in many parts of companies, energy consumption is the result of a combination of a large number of factors. In upstream production operations for oil and gas, such factors may include location, climatic conditions, reservoir characteristics, age, etc. In refining, energy consumption is dictated not only by size (e.g. in terms of crude processing) but also, and in a major way, by the complexity of the refinery. As a result, each operating facility has its own structural energy consumption that reflects the specific tasks that it carries out.

A systematic review and analysis of energy consumption forms the basis for enhanced energy efficiency. The higher the consumption the more detailed the measurement should be and, consequently, the easier it is to ascertain the savings potential.

These measurements are restricted by measurement costs, which should naturally not exceed the benefits. If you have localised big consumers, you can tighten the system boundaries of the analysis in order to obtain detailed information.

In addition to consumption data, there are other relevant factors which should be included to enable a comprehensive assessment of data. In order to maintain clarity, it makes sense to take into account the entire company, as well as individual areas (e.g. equipment, sites, and facilities), systems and processes. However, system boundaries and operational conditions should always be determined.

These can be, for example:

- Measurement interval (time, duration) and measurement accuracy
- Production stages, type of product, locations or even areas of building equipment and appliances (lighting, ventilation, etc.)

It should always be possible to explain irregularities. Therefore, alongside data for energy consumption and use, you should also record production figures, turnover and breakdowns. During the energy review, you should identify the age of your equipment and resources, as well as any visible defects. In order to determine the savings potential and to identify changes, the complete energy flow of the company should be recorded and documented.

The following essential information should be available for the energy review:

- Name of equipment

- Unique ID of major equipment (minor equipment such as fluorescent tubes, desktop PC can be grouped together)
- Equipment location
- Rated power
- Type of energy and measured energy consumption during a particular period (e.g. monthly record).

» *Process and evaluate all data for documentation*

**Documentation** plays a central role in an EnMS. Therefore, during the introduction of documentation it is very important that a clear and traceable structure be developed from the very beginning. The objective of this step is to create a clear depiction of the energy flow and document it over an extended period of time. The prepared data provide the foundation for the action plans and energy targets.

Therefore, when recording data, always make sure that they are up to date, complete, easy to maintain, as well as accessible to those responsible. Data reviews using the illustration and generation of comparative key indicators have proven valuable.

While determining these values, it is important to always establish system boundaries and operational conditions in order to avoid misrepresentation. Establish a reference period (energy baseline) in order to assess future changes with regard to energy consumption and use. This is a prominent requirement in the ISO 50001 standard. Use the results of the company's initial energy assessment when defining the reference period, and make sure to choose a reasonable period of time.

**ISO 50001 DEFINITION OF DOCUMENTATION**

*Documentation requirements*

The organisation shall establish, implement and maintain information, on paper, electronically or using any other medium, to describe the core elements of the EnMS and their interaction.

The EnMS documentation shall include:

- a. The scope and boundaries of the EnMS;
- b. The energy policy;
- c. The energy objectives, targets, and action plans;
- d. The documents, including records, required by this international standard;
- e. Other documents determined by the organisation to be necessary.

**Note:** The degree of documentation can vary for different organisations for the following reasons:

The scale of the organisation and type of activities;

The complexity of the processes and their interactions;

The competence of personnel.

» *Develop action plans*

The energy management action plan should be documented, reviewed at regular intervals at management review meetings, and amended in line with new developments, modifications, and the expansion of existing activities.

All steps described so far should be consolidated and regularly updated in the action plans so that implementation is guaranteed and the internal and external control of the EnMS is



possible. Action plans can be developed based on the collected data stock and self-defined objectives and targets.

**Example 3: Energy consumption target action plan**

**Table 2.2: Energy consumption target and implementation**

No.	Identified area for reducing power consumption	How to implement
1	Monitor and maintain ammonia compressor discharge pressure: less than 180 PSI for all plants at all times.	<ol style="list-style-type: none"> <li>1. Regularly descale ammonia condenser</li> <li>2. Ensure regular water treatment to maintain water quality in cooling tower.</li> <li>3. Monitor performance of all cooling towers</li> <li>4. Regularly purge air from receiver/condenser.</li> </ol>
2	Ensure all phases have equal voltage & current draw.	<ol style="list-style-type: none"> <li>1. Arrange power circuit redistribution, ensuring equal loading of all phases.</li> <li>2. Use phase changer switch for load balancing for office, laboratory &amp; plant lighting.</li> <li>3. Use auto transformer for office power distribution.</li> <li>4. Monitor shift for unbalanced load 3 times per day.</li> <li>5. Monitor dryer/heater performance.</li> </ol>
3	Maintain maximum earth pit resistance at 1 mega ohm & maximum leakage voltage at 4 volts.	<ol style="list-style-type: none"> <li>1. Regularly monitor earth pit resistance.</li> <li>2. If above 1 mega ohm: add water or replace salt/coal/earthing plate.</li> <li>3. With greater earth leakage, check voltage on all electrical equipment &amp; fix the problem.</li> <li>4. Check earth leakage once every 15 days.</li> </ol>
4	Running of transfer pump from sub cooler to storage tank.	<ol style="list-style-type: none"> <li>1. Automation of pump start/stop through the reboiler level.</li> </ol>
5	Improve dryer service cycle and minimise heater & blower on-time for dryer without compromising on process parameters.	<ol style="list-style-type: none"> <li>1. Check dew point regularly, specifically at the end of the dryer service cycle. Do not change dryer until dew point has reached <math>-60^{\circ}\text{C}</math>.</li> <li>2. Ensure automation is working properly for the dryer. Once the dryer outlet temp has achieved <math>110^{\circ}\text{C}</math>, the heater and blower should be tripped after 15 minutes.</li> </ol>
6	Achieve rated output from each CO <sub>2</sub> compressor.	<ol style="list-style-type: none"> <li>1. Adjust GSFC blower rpm through variable speed drive ensuring 3 to 4 PSI suction pressure to each compressor.</li> <li>2. Install blower at compressor suction connection to boost suction pressure.</li> </ol>
7	Try to reduce the water pump power consumption of the cooling tower.	<ol style="list-style-type: none"> <li>1. At one of the cooling towers try installing a low-capacity submersible pump instead of a mono block pump.</li> <li>2. Try a different orifice size to attain the correct water requirement for each heat exchanger. Consider reducing pump capacity.</li> </ol>
8	Ensure timely and effective maintenance of plant equipment & proper cleaning of heat exchanger.	<ol style="list-style-type: none"> <li>1. Strictly follow the maintenance schedule.</li> <li>2. Improve quality of maintenance work.</li> <li>3. Monitor records of process parameters before and after maintenance.</li> </ol>
9	Install KC 2 compressor at suction of compressor.	<ol style="list-style-type: none"> <li>1. Reduce CO<sub>2</sub> temp to <math>4^{\circ}\text{C}</math>.</li> <li>2. Remove moisture from raw CO<sub>2</sub>.</li> <li>3. Steps 1 and 2 will yield a dual increase in volumetric efficiency &amp; compression of drier CO<sub>2</sub>.</li> <li>4. Point number 6 above (blower to suction of compressor), will increase the compressor capacity to compensate the additional CO<sub>2</sub> capacity.</li> </ol>
10	Maintain standard plant/process parameters.	<ol style="list-style-type: none"> <li>1. Properly train all engineers.</li> <li>2. Regularly monitor and review plant/process parameters.</li> </ol>



11	Improve insulation wherever possible.	<ol style="list-style-type: none"> <li>1. Check cold &amp; hot insulation for all plants/pipelines.</li> <li>2. Reinsulate damaged insulation equipment/piping.</li> </ol>
12	Use AOD pump for water transfer.	<ol style="list-style-type: none"> <li>1. Use waste vented CO<sub>2</sub> energy for water transfer.</li> </ol>

This action plan will subsequently be used or implementation.

» **Establish action plans**

After having established the operational objectives, action plans can be prepared which include concrete measures on how the objectives are to be achieved. For each objective and the related work packages, responsibilities must be defined, a deadline established and resources for implementation provided. In addition, you must designate the how you will later review whether the set objectives and corresponding improvements in energy use and consumption have been achieved, as well as the methods used to achieve them.

These individual measures should be developed parallel to energy objectives with the help of various factors such as implementation and investment costs and payback periods. Develop measures jointly with the energy efficiency team, as well as with the employees responsible, in order to get an overview of the feasibility of the various measures in the company.

» **Documentation of action plans**

Action plans should be documented in order to simplify their implementation and monitor their effectiveness. A synopsis of the action plans should also be part of the energy report.

**Example 4: Example of an action plan**

The following example is part of an action plan for the German company BMW which already employs ISO 14001 and ISO 50001.

**Table 2.3: Practical example for developing an action plan (by BMW)**

<b>Strategic objectives</b>	<b>Measures</b>	<b>Deadline</b>
<b>Management of Resources and Environmental Protection</b>		
Breakthrough goal of a 30% reduction in energy consumption, VOC, water, process waste water and solid water per manufactured vehicle between 2006 and 2012 (5% per year)	More measures to raise employer awareness of energy saving potential	2010
	Integration of pilot project findings on consumption structures and energy flows in Munich in 2008 into all German locations	2009/2010
	Full implementation of “odour-free foundry” at the Landshut plant by 2010 and subsequent continued reduction of VOC-emissions	2010
	Decrease in drinking water consumption as a result of recycling in production and the use of other water categories such as near-surface ground water.	Ongoing
Increase application of renewable energies	Evaluate and promote the option of using wind and geothermal energies in various locations	2010

Waste management	Integrate the locations Goodwood and Rayong into the waste information system of the BMW group	2011
Nature conservation and biodiversity	Develop a biodiversity indicator for the entire network of the BMW group	2011
<b>Efficient transport logistics</b>		
Increase percentage of low-emission transport modes	Development of supply concepts from global procurement sources to the BMW's group production site by taking into consideration sustainable, environmentally friendly transport modes.	2009
Optimization of transport volumes	Development of concepts on traffic reduction (load factor) and traffic relocation to more environmentally friendly carriers.	2009

**Example 5: Examples of criteria to be considered when defining energy purchasing specifications for lighting systems**

- Unit and total cost
- Required number of lighting devices
- Power rating
- Power factor
- Energy savings percentage (i.e. compared with the traditional mercury lamp) and its payback period
- Lifetime (i.e. frequency of replacement)
- Lux level
- Colour rendering index
- Colour temperature
- Luminous efficiency
- Lumen depreciation
- Surface temperature (i.e. impact on operating cost of air conditioning system)
- Any stroboscopic effect?
- Any need for special disposal?
- Any hazardous materials or heavy metals inside in the equipment?
- After-sale maintenance service

**DO**

In order to achieve the maximum financially attractive energy savings, the measures determined in the action plans should be prioritised and translated into a detailed work plan.

Along with including the responsibilities and timeframe for various activities, the work plan should account for all necessary resources. The stipulated energy objectives and targets can thus only be achieved if sufficient financial and technical resources are available. Furthermore, the Energy Manager should systematically record the success of measures and activities in order to facilitate the realisation of energy objectives and targets and conduct a cost-benefit analysis of the implemented measures. Success indicators are savings in costs and

reduced environmental pollution, as well as positive press reviews or positive feedback from employees.

Always maintain an energy savings register that records all the implemented measures together with their predicted savings potential.

After having successfully planned an EnMS, it is now time for the actual **implementation**. During the implementation phase (“DO”), the activities which were determined in the action plans are performed.

The following steps must be considered to ensure an **effective implementation** of the EnMS:

1. Budgeting and securing the necessary resources for implementing the EnMS and establishing the action plans
2. Building and increasing awareness
3. Employee and partner training
4. Communicating about the EnMS
5. Documentation of the EnMS and monitoring the documentation
6. Operational control of all relevant processes, including acquisition, purchasing and maintenance
7. Annual revisions of the action plan to align with changing realities

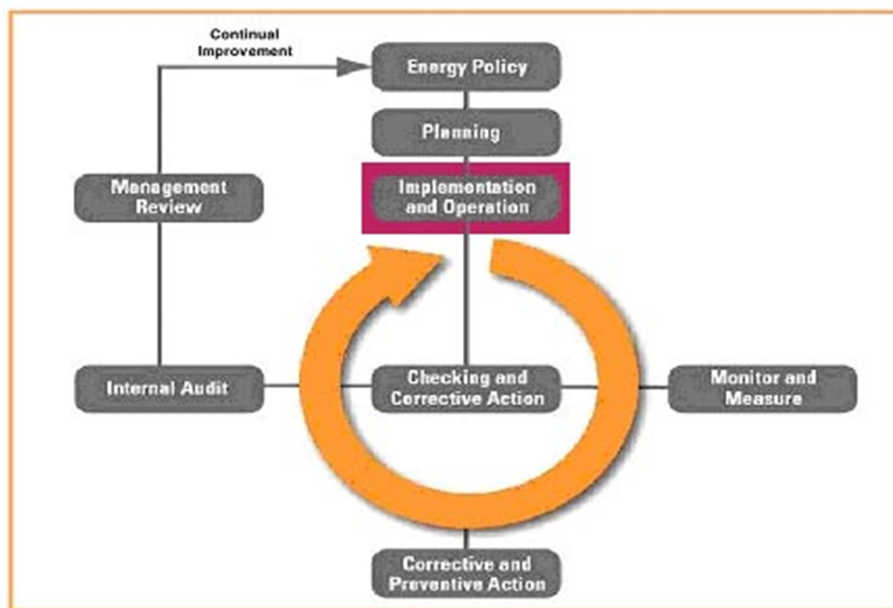

Figure 2.9: Management cycle – Source: [www.slideshare.net](http://www.slideshare.net)

#### » Legal requirements

**Note:** Before starting to implement an energy management system with the goal of subsequent certification, you must ensure **compliance with all legal requirements**. Otherwise, the company cannot initiate the certification process.

While implementing ISO 50001, it is essential to adhere to all currently applicable and relevant laws, regulations and ordinances. This applies in particular to laws relating to energy consumption, energy use and energy efficiency.

Pay particular attention to the following, if applicable to your country:

- Energy saving regulation (EnEV 2014)
- Renewable Energy Sources Act (EEG)
- Act on Energy Services and Energy Efficiency Measures (EDL-G)
- Energy Saving Act
- Air Pollution Control Act
- Energy-using Products Act
- Best available techniques (BAT)

Other environmental laws, as well as the occupational safety and health legislation should also be taken into account.

Companies usually maintain a register of legal obligations so that specific provisions are not forgotten. This register contains all relevant laws and regulations which are necessary for their operations. For smaller businesses, a summary table is often sufficient, while a database is recommended for larger businesses.

#### » *Responsibilities of top management*

For the long-term success of an EnMS, the motivation of employees and the commitment shown for an EnMS are of major importance.

This includes all levels and functions of an organisation and begins at the highest management level of a company, the top management.

According to ISO 50001, the responsibilities of **top management** within the framework of an EnMS include above all:

- Defining and continually maintaining an energy policy for the organisation.
- Ensuring the availability of required resources for introducing, attaining, maintaining, and improving the EnMS (personnel, special capacities, technical and financial resources).
- Appointing a management representative (“Energy Manager”) with established responsibilities and powers for implementing an EnMS. This person should also be responsible for submitting the report on performance and the results of the system to top management.
- Deciding on further strategic energy management measures on the basis of documented energy results in internal audits.
- Reviewing the EnMS of the organisation at regular intervals to test it for results. This review should be recorded and maintained as part of management reviews.
- Communicating the importance of the EnMS within the organisation.

#### » *Top management appoints an Energy Manager*

As a first step in the implementation process, top management appoints a management representative (“Energy Manager”) tasked with implementing the EnMS. He/she is the key person who is responsible (if not solely) for compliance with the requirements specified in ISO 50001. His/her tasks and authority should be documented and communicated to the other employees. To be able to carry out his/her tasks, the Energy Manager needs sufficient skills, motivation, the necessary authority and the full support of top management. Among other

tasks, the Energy Manager is responsible for defining criteria and methods to ensure the effective function and monitoring of the EnMS.

His/her tasks include:

- Looking after the implementation of the EnMS
- Checking and controlling results, correcting instances of noncompliance
- Communicating all results to top management
- Serving as an interface between top management and employees
- Controlling the energy team
- Selecting the energy team depending on the company size
- Representing his/her activities within the company
- Providing periodical reports to employees and management
- Communicating achieved savings
- Contextualising achieved performance in striking ratios

#### ***Example 6: Example of an internal job description for an Energy Manager***

##### **Tasks:**

- Setting up and leading the energy team in the company
- Planning and implementing projects (according to budget, time and quality)
- Acquisition, processing and communication of energy-related information
- Delegating tasks and setting time limits
- Supporting the involvement and recognition of the top management
- Attaining staff support beyond individual areas and functions
- Regularly reporting to the top management on energy performance and the performance of the EnMS

##### **Required qualities of the Energy Manager:**

- Good knowledge of operating procedures
- Excellent capabilities in project management, in organisation and communication
- Sound knowledge of ISO 50001, 50002, energy audits
- Basic technical understanding
- Trust and respect of co-workers
- Involvement and enthusiasm for the subject of energy management
- Listening skills, ability to handle different opinions and ideas

The Energy Manager shares responsibilities and tasks with the members of the energy team. Regular meetings should take place for coordination. The frequency of these meeting can be based on demand; they must, however, take place at least once every quarter. Top management should be included at least once a year.

#### **» *The Energy management team***

As it can be seen in the graphic below, the Energy Manager has direct ties to top management. The first task of the Energy Manager is to put together and coordinate an energy efficiency team. As energy efficiency affects almost all areas of your company, it is important

that the Energy Manager work together with the officers in charge of all relevant departments. When selecting team members', technical knowledge and motivation play a decisive role. Motivation is more important to success than technical knowledge, since this knowledge can always be obtained through an external adviser when necessary.

The task of an energy efficiency team lies essentially in implementing and maintaining the EnMS. This includes:

- Developing an effective organisational structure to integrate the EnMS into the operational organisation
- Establishing and maintaining an energy information system for internal communication
- Developing an energy management programme using a comprehensive data assessment and evaluation process, as well as developing and implementing measures to increase energy efficiency.

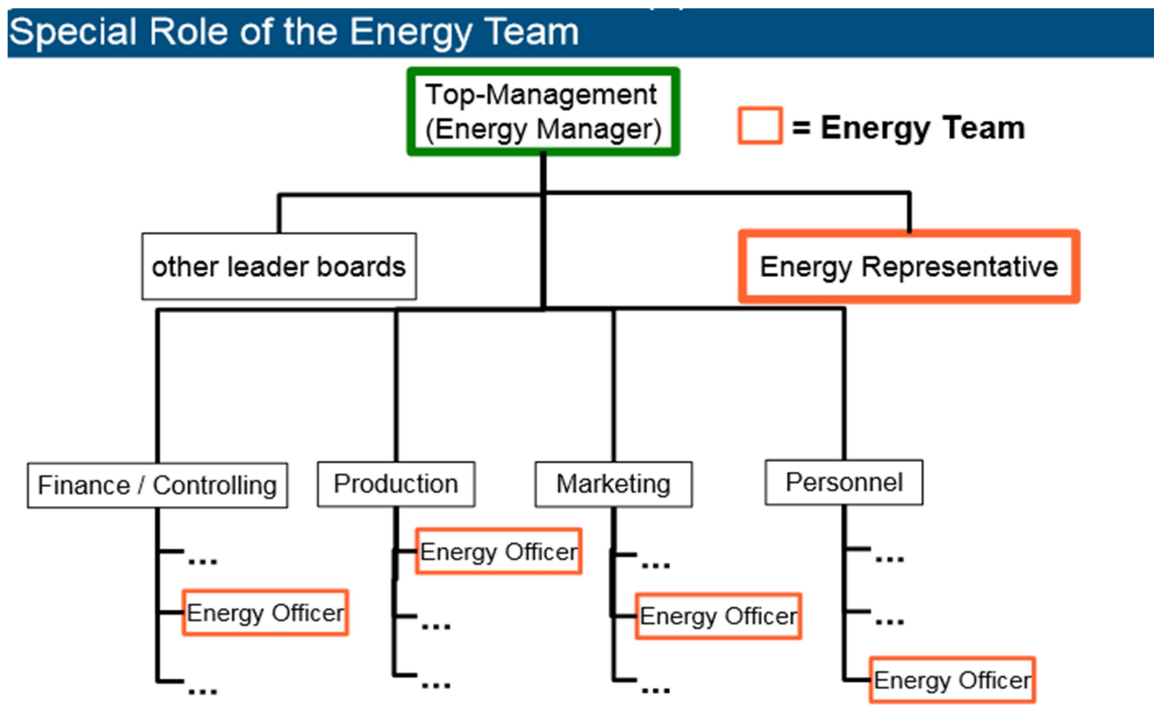

Figure 2.10: Integration with existing systems, management and technology requirements – Source: GIZ

Begin with the implementation of those measures that guarantee quick success, require very little or no investment and contain easily quantifiable energy cost savings. This leads to a distinct sense of achievement which makes it easy to communicate the advantages of energy management and to systematically tie the EnMS into the organisation. Formulate individual measures like other projects to be implemented within your company. This will simplify the implementation procedure for employees.

Measures requiring minimal investments mostly entail organisational changes such as establishing responsibilities, systematic data acquisition, switching off machines and devices when not in use, etc. Modifications to energy supply contracts also fall under this category.

Sometimes, simple changes in employee behaviour can lead to energy and cost savings of up to 50%. However, problems that can arise during the implementation process should not be underestimated and well-defined responsibilities should be determined.

When undertaking measures that do require investments, it is important to include suppliers and sub-contractors in decisions about these investments in order to realise the greatest possible savings.

Always ensure the availability of required resources for the implementation of the EnMS and ensure that no action is part of the plan that does not have the support of management or is not within the financial means of the company.

**Top management must guarantee** the availability of all required technical and financial resources to ensure a smooth implementation of measures from the action plan.

» *Building and increasing awareness*

To guarantee the function of an energy management system it is necessary to determine whether all affected employees possess the necessary knowledge and expertise in order to carry out their tasks in the area of energy management. This applies to the energy management team as well as all other relevant persons.

You can build and increase awareness through a variety of different channels. Appropriate channels include, for example, information campaigns, flyers, information screens, email signatures, articles in employee newsletters or the company intranet. In any case, it is important to motivate employees to participate.

Furthermore, it is important that top management set a good example. Simple attitude changes can be adopted much more easily if top management is committed and communicates this emphatically.

**Employees should be aware of:**

- Advantages of energy efficiency for the company and for the environment
- Importance of compliance with the energy policy
- Requirements of the EnMS
- Consequences of noncompliance with EnMS specifications
- Potential impact of their own individual activities on energy consumption and achieving the energy objectives and targets
- Their specific duties, responsibilities and competencies in implementing the energy management system according to ISO 50001

**FACILITATING EMPLOYEE & PARTNER TRAINING AND PROFESSIONAL DEVELOPMENT**

After having defined responsibilities, it is necessary to find out whether participating employees have the skills required to fulfil their duties and responsibilities under the EnMS.

Appropriate training leads to the establishment of the relevant and necessary competencies in the company, as well as awareness of the importance of energy management among individual employees.

Apart from concrete professional training measures for individual employees, training programmes for conscious energy use in the company should also be prepared. Training materials should also be updated on a regular basis.



Make sure that training and awareness of the topic of energy management does not remain limited to your own company but instead also includes all suppliers and contractors.

#### **COMMUNICATING ABOUT THE ENMS IN YOUR COMPANY**

As part of internal communication, relevant procedures could include how staff members are made aware of energy issues, how decisions are made or information is disseminated to staff, etc. Provisions may also be made for the communication and handling of energy management-related suggestions and complaints. Communication links should clearly be demonstrated in horizontal and vertical directions within the organisation. Communication procedures should also cover the process of responding to comments and suggestions by contractors working for or on behalf of the organisation. Communication methods include, for example:

- Meetings
- Videos
- Briefings
- E-mails, posters, memos, circulars and
- Suggestion boxes, employee hotlines.

When communicating aspects of an EnMS, it is important to differentiate between internal and external communication channels. According to ISO 50001, internal communication is obligatory and closely related to raising employee awareness of EnMS implementation.

#### **Communicate the following aspects of the EnMS:**

- Energy policy, objectives and targets
- How individuals can contribute to energy management
- Information on energy consumption and trends within the company
- Compliance with legal and other requirements
- Room for improvement
- Financial and environmental advantages of energy management
- Contact person(s) for further details

Apart from communicating to raise the general awareness of employees, it is important to regularly communicate the most important aspects of the EnMS. Integrate the results of measurements and the energy indicators and aspects collected for the energy management system into your internal controlling. This ensures regular internal communication of the EnMS results for all employees up to top management.

The **external communication** of EnMS results is **not mandatory**; however, it does help portray your company in a positive light and enhance your corporate image.

Externally, the organisation should maintain a documented decision on whether it will communicate its energy policy, EnMS and energy performance. For organisations that choose to communicate this information externally, the following aspects should be considered:

- Approval process for public domain content
- Type and level of information to be communicated
- Target groups of communication
- Mechanisms and responsible parties to handle and respond to enquiries

- Official response time and
- Recording system, communication format, and associated correspondence.

Even if it is **not compulsory** to communicate the company's activities externally, it still remains important. If management decides in favour of external communication, the next steps are to define the respective responsibilities as well as which information to communicate in which manner.

All collected comments and suggestions for improvement should be reviewed and answered. Appoint a person-in-charge and draft a plan for internal communication within the framework of energy management – this simplifies the information flow.

### *Definition of communication by ISO 50001*

#### **4.5.3 Communication**

The organisation shall communicate internally with regard to its energy performance and EnMS, as appropriate to the size of the organisation.

The organisation shall establish and implement a process by which any person working for, or on behalf of, the organisation can make comments or suggest improvements to the EnMS.

The organisation shall decide whether to communicate externally about its energy policy, EnMS and energy performance, and shall document its decision. If the decision is to communicate externally, the organisation shall establish and implement a method for this external communication.

#### » **Documentation of the EnMS**

Documentation within a management system will assist in both EnMS implementation and promoting understanding of the system's implementation. Documentation helps the organisation communicate its intent and ensure that all energy-related activities are performed consistently and according to requirements.

All key elements of an EnMS should be captured either on paper or electronically and then recorded. The documents should be easily accessible and therefore filed systematically. If a documentation system is already in use at the company, using it for the EnMS can save effort and costs.

Anyone who is responsible for the documentation of one or more working areas should always have access to the documents. Ensure that the documentation system is monitored regularly and always kept up-to-date.

All processes related to energy must be documented. Document the reasons for implementing a certain measure, as well as the areas of consumption and activities in daily work routines that are affected by a certain procedure.

#### **MONITORING DOCUMENTATION**

Make sure that all documents contain the correct statements before their release. In addition, all documents should regularly be monitored for accuracy and periodic updates. Ensure that the latest documents are well protected against damage, loss or destruction. Relevant versions of applicable documents must be available at the site of use. For legal reasons, a few obsolete documents also need to be kept. Ensure that these documents are clearly separated from current documents to prevent unintentional use of out-of-date versions and/or obsolete documents.

All documents can be kept electronically in addition to paper versions and should include information on energy efficiency in processes, design and procurement. All documents have to be at hand for presentation in case of an external audit.

**ENERGY-CONSCIOUS DESIGN**

Energy-efficient design should be a primary consideration when designing, modifying or renovating plants, facilities and buildings. Ensuring the use of energy-efficient alternatives, low energy standards or alternative energy sources in new facilities and utilities and new production lines will save both energy and costs.

When implementing energy-efficient designs, it may be advisable to collaborate with an external consultant. Always consider and identify energy performance improvement opportunities at the beginning of design, renovation or modification activities for significant energy-consuming facilities, equipment, systems and processes.

**Guidelines for energy-conscious design:**

- Always perform an in-depth analysis of energy consumption in the very first phase of the development project.
- Conduct an energy review at all relevant development steps (proposals, first detailed design, final design, selecting the equipment, delivery, commissioning, et cetera).
- Clearly establish the responsibilities of persons-in-charge for an energy-conscious design.

**ENERGY-CONSCIOUS PROCUREMENT**

Even when purchasing machinery, equipment, raw materials and services, it is possible to save a great deal of energy. Make energy efficiency an evaluation criterion in the procurement processes, and make sure that the entire life cycle is always considered when assessing energy consumption and energy efficiency. Determine relevant criteria and calculation methods such as the calculation of the payback period, or alternative and potentially more useful methods (e.g. internal rate of return, net present value method).

**CHECK & ACT**

According to ISO 50001, an important aspect of energy management is the continuous improvement process. A further certification after a three years' cycle is only granted when all or nearly all energy targets have been achieved. Verifiable results must be provided to the certification company which executes an external audit.

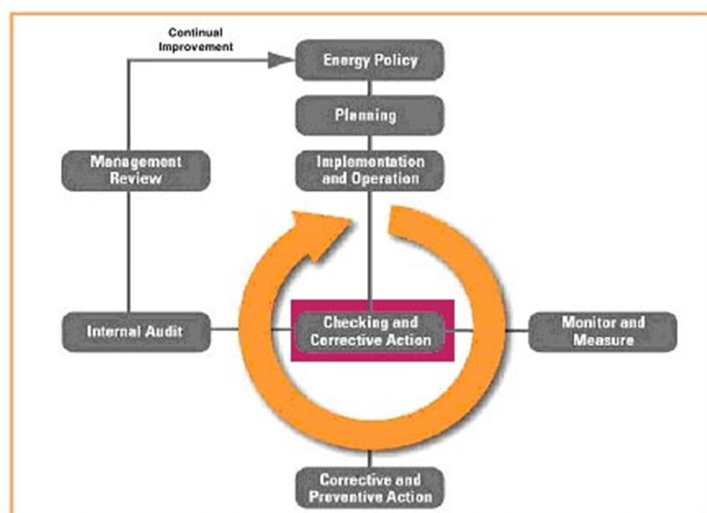

Figure 2.11: Checks and corrective actions within the management cycle

This requires regular checks to determine whether all energy objectives and targets are being met and if the EnMS is functioning optimally. Corrective measures should be implemented as needed.

Aspects to consider during a regular review:

- Monitoring and measurement
- Reviewing compliance with legal obligations
- Internal audits
- Nonconformity, corrective and preventive actions
- Planning and structuring records
- Review by top management

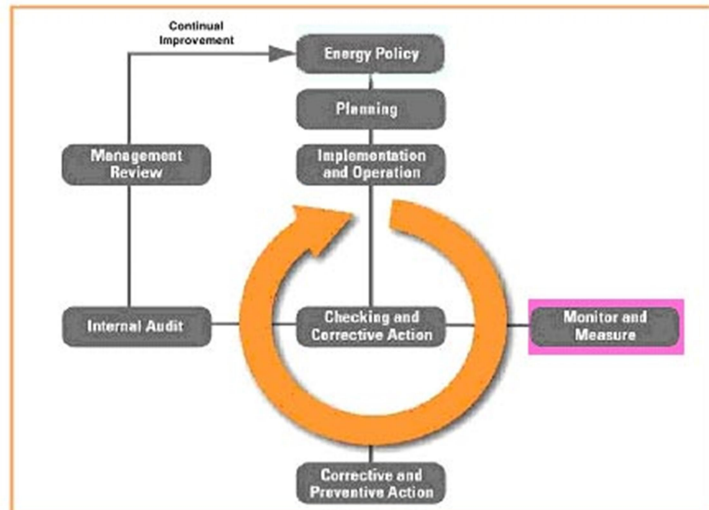

Figure 2.12: Monitoring and measurements within the management cycle

» **Regular monitoring and measurement of EnMS results**

Inefficient energy consumption can be promptly detected with frequent and regular comparisons of expected and actual energy consumption. In any case, the areas of significant energy use and the relevant factors for energy consumption must be monitored. Depending on the type of organisation, one would measure for example the energy consumption of processes, compressed air, heating or lighting. The typical time period depends on the type and size of the organisation and individual facilities. Measurements can be performed as real-time measurements, or be carried out in monthly or even less frequent intervals. Drafting a monitoring schedule can facilitate monitoring activities.

**Aspects of regular monitoring:**

- Consideration of relevant factors that influence energy consumption
- Examination of significant areas of energy use
- Energy performance indicators
- Reviewing the effectiveness of action plans
- Comparing current and expected energy consumption.

The energy baseline must be adjusted as a reference value whenever significant changes have occurred in operations or the previously specified EnPIs are no longer appropriate for measurement.

**Important:** The relationship between energy factors and energy consumption must be reviewed on a regular basis to ensure that consumption is assessed based on the current best possible performance.

Organisations should always have an energy measurement plan. Its level of detail should depend on the particular requirements. The following points (among others) should be kept in mind for the plan:

- Scope of monitoring
- Measurement intervals
- Methods for measuring energy consumption
- Maintenance of measurement instruments
- Assignment of responsibilities

**Example 7: Example for scope of monitoring**

EnMS scope and boundaries:

The EnMS Manual is applicable to the Organisation’s operations for all the activities carried out at our plant and implemented for the Manufacture and Supply of Optical Whitening Agents. The boundaries of the energy management system are defined in the system for all facilities and equipment used at the plant located at 902-903-904, ‘Samudra’ Annexe, Near Hotel Classic Gold, Sardar Patel Nagar, Off. C.G. Road, Ahmedabad–380 006, Gujarat, India. It covers the energy management system for all products manufactured and processes used by company employees as well as contract labourers for all plant activities that significantly affect energy use and consumption.

Source: GIZ

**ISO DEFINES THE CHECKING PROCESS AS FOLLOWS**

*Checking: Monitoring, measurement and analysis*

These procedures provide quantitative as well as qualitative measures to meet company needs as well as monitor the key characteristics of operations, which have significant energy impacts, and achievements of the EnMS objectives, operational process and activities.

Key characteristics included in the procedure are:

- a) Significant energy uses and other outputs of the energy review;
- b) Relevant variables related to significant energy uses;
- c) EnPIs;
- d) Effectiveness of the action plans in achieving objectives and targets;
- e) Evaluation of actual versus expected energy consumption.

Equipment used for monitoring and measuring (such as clamp meters, energy meters, etc.) is also calibrated/verified to ensure accuracy/required precision as per the documented procedure. The calibration records or verification records are maintained as a means of establishing accuracy and repeatability. Any significant deviations in energy performance are investigated and responded. Results of these activities are recorded and discussed in the energy management review meeting.

Evaluation of compliance with legal requirements and other requirements.

Procedure is documented and implemented for periodic evaluation for compliance with the applicable legal requirements for energy use and consumption. Records of such periodic evaluation are maintained in the Register of Rules and Regulations.

.....

Non-conformity, corrective and preventive actions

Procedure is documented and implemented for dealing with the actual and potential non-conformity and for taking corrective and preventive actions. Procedure also defines responsibility and authority for analysis, handling, investigating non-conformity and taking action to mitigate any consequences from non-conformity and for initiating and completing corrective and preventive actions. Procedure

also defines the following aspects:

- a) Reviewing actual or potential non-conformities;
- b) Determining the causes of actual or potential non-conformities;
- c) Evaluating the need for action to ensure that non-conformities do not occur or recur;
- d) Determining and implementing the appropriate actions needed;
- e) Maintaining records of corrective and preventive actions;
- f) Reviewing the effectiveness of the corrective or preventive action taken

.....  
Control of records

The company maintains legible, identifiable records of the Energy Management System as described in various sections of this manual to demonstrate conformity to the requirements along with the results achieved against each performance indicator and records are traceable to relevant activities. Procedure is documented and implemented for the identification, collection, indexing, access, filing, storage, protection, retrieval, retention time and disposition of EnMS records. ....

#### MONITORING AND ASSESSING LEGAL COMPLIANCE

Compliance with legal obligations and other requirements should be assessed on a regular basis. This assessment requires a written review which can furthermore be used to keep the legal register up-to-date.

##### » *Internal Audit of the energy management system*

The internal audit of an EnMS differs from – and should not be confused with – an energy audit or assessment.

**In management systems like ISO 50001, the internal audit refers to the system itself** and is different from the energy audit, which specifies the process requirements for conducting an energy audit in relation to energy performance.

Internal audits of a management system usually include four audit types:

**System audit:** Verification that standard specifications are integrated in the management system (importance decreases substantially as the age of the management system increases). System audits focus on records, statements of fact or other information which are relevant to the audit criteria and verifiable, including:

- Documentation
- Measurement records
- Protocols
- General information

**Performance audit:** Independent examination of a programme, function, or operation of the management systems and procedures. Performance audits endeavour to verify the **implementation** of internally defined processes and workflows and the pursuit of goals. Processes are audited to ensure the quality of data acquisition, pinpoint the causes of deviations and determine the need for corrective action.

**Compliance audit:** Comprehensive review of an organisation's adherence to **regulatory guidelines** and a verification of compliance with applicable **legal regulations** and commitments.



**Continuous improvement audit:** Identification of potential savings culled from meetings and suggestions submitted by employees, from on-site inspections, and from the joint analysis of current data and facts.

These four different audits provide an on-going review of the function and performance of the management system. The audit findings are then the results obtained by evaluating collected audit evidence and comparing it against the audit criteria. Findings may be categorised as

- Conformities
- Non-conformities (major and minor)
- Recommendations

At the end of the audit, the audit conclusion summarises the outcome of the audit following the consideration of the audit objectives and all audit findings. The conclusion can include:

- Degree of overall conformity
- Measures to improve conformity or performance

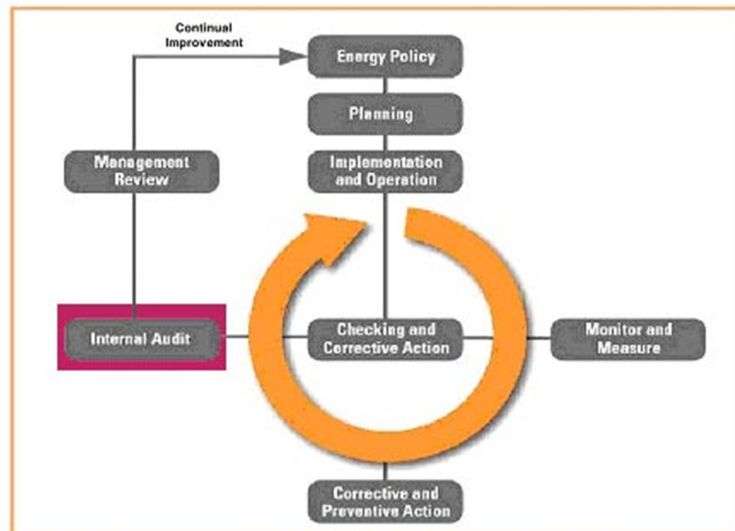

Figure 2.13: Internal audit within the management cycle

**INTERNAL AUDIT, DEFINITION BY ISO**

(Enumeration follows ISO 50001)

**Internal audit of the EnMS**

Internal audit of energy management system EnMS audit is carried out at least once in six months to:

- a) Determine whether the energy management system;
  - i. Conforms to the planned arrangements for the energy management system and ISO 50001 requirements
  - ii. Is implemented and maintained in accordance with the requirements of the energy management system
- b) Provide information on the results of audits to the top management for effective operation of the energy management system.

Audit programme is planned and implemented and maintained by the company. While programming the audit of the particular function, consideration is given to the energy importance and results of the previous audit.

Procedure is documented and implemented while defining the scope, frequency, methodologies and competencies as well as reporting the results.



### » *Energy audit*

The following chapter presents a short overview of the energy audit as specified by ISO 50002 in order to illustrate differences to the system audit (ISO 50001).

**Note:** Both audits overlap because parts of the energy audit (ISO 50002) are components of the energy system audit (ISO 50001).

You will find the complete procedure outlining the energy audit in Module 6.

#### **ENERGY AUDIT (ISO 50002)**

This chapter refers to the energy audit as described in ISO 50002. Although it is not part of ISO 50001, the main focus of the present module, it shall be introduced here as essential background knowledge for ISO 50001. This chapter explains the expected practical and energy reduction components that should result from energy management.

The purpose of an energy audit (sometimes called an “energy assessment” or “energy study”) is to determine where, when, why and how energy is used in a facility, and to identify opportunities to improve efficiency. It is mainly part of **ISO 50002** (see section 4.6 for a detailed description).

#### *ISO 50001 and 50002: Definitions and differences*

**The international norm ISO 50001: 2011** specifies the requirements for establishing, implementing, maintaining and improving an **energy management system**, whose purpose is to enable an organisation to follow a systematic approach in continually improving its energy performance, including aspects such as energy efficiency, energy security, energy use and consumption.

**The international norm ISO 50002:2014** is a supplementary document to ISO 50001. It specifies the process requirements for carrying out an **energy audit** in relation to energy performance. ISO 50002 is applicable to all types of establishments and organisations, and all forms of energy and energy use.

An **energy audit** refers to the inspection, survey and analysis of energy flows, for energy conservation in a building, process or system to reduce the amount of energy input to a system without negatively affecting the output(s).

#### *Energy audit as defined by ISO 50002*

Systematic analysis of energy use and energy consumption within a defined energy audit scope, in order to identify, quantify and report on the opportunities for improved energy performance. In any commercial and industrial real estate, the energy audit is the first step in identifying opportunities to reduce energy expenses and carbon footprints.

An energy audit comprises a detailed analysis of the energy performance of an **organisation** (defined by ISO as a company, corporation, firm, enterprise, authority or institution) or of equipment, system(s) or process(es). An energy audit is based on appropriate measurement methods and the observation of energy use, energy efficiency and consumption. Energy audits are planned and conducted to identify and prioritise opportunities to improve energy performance, reduce energy waste and obtain related environmental benefits. Audit outputs include information on current use and performance and they provide ranked recommendations for improvement in terms of energy performance and financial benefits.

**Note:** If an energy audit meets the requirements of the systemic approach as described in the ISO 50002 standard, then it can be integrated into the ISO 50001 standard (energy management).

#### TYPES OF ENERGY AUDITS

Energy audits typically take a whole building approach by examining the building envelope, building systems, operations inside the building like production activities and maintenance procedures, and building schedules. Whole building audits provide the most accurate picture of energy savings opportunities at your facility.

##### *Home energy audits*

A home energy audit is a service where the **energy efficiency** of a house is evaluated by a person using professional equipment, with the aim of suggesting the best ways to improve the energy efficiency of applications such as heating and cooling.

##### *Industrial energy audits*

For industrial applications, HVAC systems, lighting and production equipment (production lines, machines) use the most energy, and are thus the primary focus of energy audits. This refers as well to offices, institutions, etc.

#### ENERGY AUDIT PROCESS

To learn more about the energy audit process, please see section 4.6 “The energy audit process”.

The energy audit process specifies the process requirements for carrying out an energy audit in relation to energy performance. It is applicable to all types of establishments and organisations, and all forms of energy and energy use.

##### *Energy audit process components*

- Assessment of the general level of repair, housekeeping and operational practices that have a bearing on energy efficiency
- Definition of the energy-consuming system to be audited (scope)
- Collection, organisation, summary and analysis of historical energy billings and applicable tariffs
- Determination and comparison of energy use indices
- Determination of the time relationships of energy use, such as the electricity demand profile
- Preparation of a list of all energy-consuming loads in the audit area to identify the base line for energy consumption
- Identification of operational and technological measures to reduce energy waste
- Determination of potential energy and cost savings, along with any co-benefits

**Note:** The energy audit (following ISO 50002) serves as the foundation for verifying improvements effected by the management system to external auditors for certification purposes. The auditor will check all the documents related to the energy management system function as well as documents on the success of the energy reduction measures.

**Here the energy audit ends.** At this juncture, we return to ISO 50001, the energy management system.

» **Procedure for energy management system audits**

Internal audits (preferably every 6 months or at least once a year) should include a systematic review of the EnMS.

The aim of the energy management system audit is to further develop the functionality of the EnMS, the energy management programmes, objectives and targets, et cetera, and to help develop new measures for optimising energy management.

An audit is a systematic element of the internal review of the EnMS and thus an important step for **continuous improvement**. Therefore, one should not see this type of audit as merely a control measure but as an opportunity to further improve the company.

The management audit should take place at least once a year. It can be conducted by company employees who have the required skills and knowledge about the EnMS, ISO 50001, and relevant aspects for analysis but who remain outside the direct management of the EnMS. As an alternative, external auditors may be consulted.



Figure 2.14: Audit process

Audit checklists and timetables should be prepared as a form of guidance during the audit for all participants. Note the type of resources used, the place and time of the audit as well as the name of the persons responsible (see Table 2.4 below).

At the beginning of the audit, explain the objective of the management audit to all employees directly connected to the EnMS elements which are to be audited. It is important to explain that the audit aims to assess the effectiveness of the EnMS and not individual employee performance.

Table 2.4: Excerpt from an audit timetable

Time	Topic	Department	Auditor	Staff audited	Place (room)	Reference chapter in ISO 50001
9:00 to 10:00	Verification of the audit plan	Engineering department	Internal Auditor Mr. XY and external Auditor Mr. AB	Engineering department Managers, CEOs	Room No. 1	
10:15 to 11:00	Energy policy	Board of Directors	Internal Auditor Mr. XY and external Auditor Mr. AB	Managing Director	Room No. 2	4.2 Management responsibility 4.2.1 Top management 4.2.2 Management representative 4.3 Energy policy
11:00 to 12:00	Overview of documents about assembly hall No. 5	Production (walk-through if desired by the external auditor)	Internal Auditor Mr. XY and external Auditor Mr. AB	Manager of production section, responsible engineers for respective production units, labourers	Assembly hall no.5 or office room if no walk-through takes place	4.5.2 Competence and awareness 4.5.5 Operational control

During the audit, the external auditor will check all required documents that pertain to system implementation. All the documents in question will be reviewed and evaluated by the external auditor. The auditor will

- Determine the current energy performance
- Assess the effectiveness of the EnMS, as well as its processes and systems
- Compare the results with the energy objectives and targets
- Assess the information for benchmarking
- Check the analysis of problems and weaknesses
- Assess suggestions about possibilities for continuous improvement

The auditor will check the results of your own internal energy audit and the **energy report** containing all current energy data obtained in the internal energy audit). Apart from the status quo of the energy management system, the report should also contain a description of follow-up activities, monitoring and measurement of results, as well as a description of responsibilities.

The energy report not only focuses on the improvement of the EnMS but also refers directly to energy efficiency. It compares the results of the activities with plans and energy targets of the energy management programme and determines by how much energy consumption and energy efficiency have actually improved. This is simultaneously the main focus of an energy audit.

**Note:** The final report should have been previously presented to the top management, as well as to those employees whose job area is affected by the energy audit.

## → EXAMPLE FOR PREPARING AN ENERGY REPORT (KEY POINTS)

Energy Report, Second Half-Year 2012	
1	Short company profile (incl. company processes & products)
2	Energy sources & energy consumption (July - Dec. / 2012)
3	Energy targets as of 31.12.2012 Achievement of targets as of 31.12.2012
4	Identified measures for 2012 Achieved measures in 2012
5	Synopsis of energy management programme
6	Required corrective measures
7	Next steps

Figure 2.15: Main chapters of an energy report – Source: German Federal Environment Agency

The energy report, as seen above, is an internal company document which details the success (or shortcomings) of the implementation of energy saving measures. It reports the outcome of the energy assessment referred to in ISO 50002.

» **Corrective actions (in case of nonconformities) directed at the management system**

If the requirements that ISO 50001 sets for the EnMS are not fulfilled, then corrective action has to be taken. This is applicable, for instance, when the behaviour of employees or the development of the company are not conforming to the energy policy, energy objectives and targets, or the energy programme.

Deviations and their causes must be identified to ensure that these problems are not repeated. Although such deviations should be documented, there are no set guidelines on how to respond to them. If nonconformities are identified, the necessary corrective and preventive actions must be initiated and implemented. However, an evaluation of the effectiveness of countermeasures is required as well. Management should maintain a follow-up system to ensure that corrective and preventive actions have been completed and are effective.

The plan for elimination of nonconformities includes:

- Analysis of the cause or problem
- Identification and means of implementation for corrective actions
- Modification of existing controls, if necessary
- Establishment of preventive measures
- Recording any changes in written procedures resulting from corrective or preventive actions
- Ensuring follow-up actions are in place to ensure satisfactory resolution of non-conformance.

### » *Control of records*

Organisations are required to keep legible, identifiable and traceable records in order to demonstrate the effective functioning of an EnMS. These documents prove that all procedures conform to ISO 50001. A comprehensive system for managing and maintaining records is necessary to ensure that records are easily identified, collated, indexed, filed, stored, retrieved and maintained for an appropriate length of time.

Companies must keep records of their energy-related activities. These records document the realisation of energy objectives and targets, energy programmes and action plans. The actual records which are kept depend on the individual company and must conform to the requirements of the EnMS. They should be traceable, legible and accessible and should be directly assigned to the relevant processes, activities or persons.

Records should be kept in electronic or written form at a place which is accessible to involved staff. In addition, a copy of the **SOPs (standard operating procedures)** for the operation of certain machines or other very detailed procedures must be kept at the appropriate location and always accessible to the respective staff.

Records should contain:

- Methodology, criteria and results of energy review
- Opportunities for improving energy performance
- Energy baseline
- Energy performance indicators
- Training records
- Internal communication records
- Decision on whether to externally communicate its EnMS and energy performance criteria and results
- Design activity results
- Monitoring and measurement results of key operational characteristics
- Calibration records
- Compliance evaluation results
- Internal audit programme and results
- Non-conformance records
- Corrective and preventive action records and
- Management review agenda and minutes.

### » *Management review (management board)*

A review of the EnMS should be undertaken by top management at regular intervals (preferably every 6 months) to evaluate the suitability and effectiveness of the energy policy, objectives and targets, indicators, as well as the general state of your energy management system.

The management review is not only an assessment of the status quo of your EnMS but also an important tool for the identification of possibilities for improving energy efficiency in the company.



In order to ensure that the suggestions given by top management are also taken into consideration, the review shall be documented, for instance, in the form of a protocol or an action plan. Furthermore, follow-up measures and responsibilities for implementing the suggestions must be identified. The management review should also address external issues relevant to the energy performance of the organisation and identify opportunities for improvement and, where appropriate, changes of emphasis or direction based on the results of the energy audit. Management should conduct an intensive **at least** once a year.

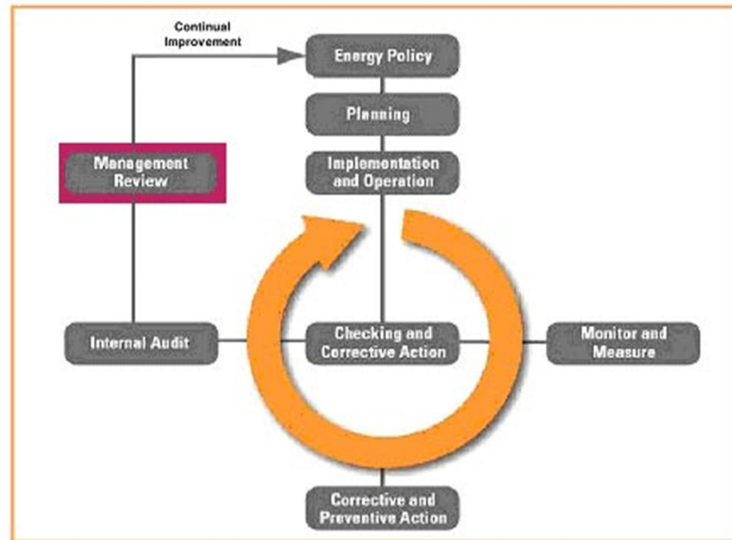

Figure 2.16: Management review within the cycle

#### DEFINITION OF A MANAGEMENT REVIEW BY ISO

#### 4.7 Management review (enumeration follows ISO)

##### 4.7.1 General

At planned intervals, top management shall review the organisation's EnMS to ensure its continuing suitability, adequacy and effectiveness.

Records of management reviews shall be maintained.

##### 4.7.2 Inputs to management review

Inputs to the management review shall include:

- a. Follow-up actions from previous management reviews;
- b. Review of the energy policy;
- c. Review of energy performance and related EnPIs;
- d. Results of the evaluation of compliance with legal requirements and changes in legal requirements and other requirements to which the organisation subscribes;
- e. The extent to which the energy objectives and targets have been met;
- f. EnMS audit results;
- g. Status of corrective actions and preventive actions;
- h. Projected energy performance for the following period;
- i. Recommendations for improvement.

##### 4.7.3 Outputs from management review

Outputs from the management review shall include any decisions or actions related to:

- a. Changes in the energy performance of the organisation;
- b. Changes to the energy policy;
- c. Changes to the EnPIs;

- d. Changes to objectives, targets or other elements of the EnMS, consistent with the organisation's commitment to continual improvement;
- e. Changes to the allocation of resources.

#### » *Certification, assessment and external communication*

Once a company has fully introduced an EnMS, it has the option to seek certification for the system through an independent external certifier. This enables the company to increase the relevance of the energy management system and simultaneously improve the company's image. This certificate means that the company has officially demonstrated compliance with the requirements of ISO 50001. Certification is carried out by an independent third party.

Certificates should be renewed on a regular basis. That includes conducting an audit in order to check if the company is continuously improving its management system. Therefore, companies are best advised to select a certification body very carefully, as this business relationship should last for several years. The certification process has to be reiterated every three years, but it is usually checked by the certifying agency on an annual basis.

#### **INITIAL CERTIFICATION**

Once the company has selected a certifier, a first pre-audit is usually carried out. Depending on the particular certifier, the pre-audit looks at the company's location, business strategies, requirements of the standard that the company has already fulfilled, etc. Based on these early assessments, the core points of the measures to be undertaken can be established. In a second step, the documentation of the energy management system is reviewed to determine the extent to which it already complies with the requirements of the ISO 50001 standard.

During the actual certification audit, the certifying auditors look at the extent to which the functionality of the energy management system implemented fulfils the conditions of the standard in practice. It thus primarily compares the company's actual performance against defined targets. The cost of this certification audit depends on the certification body engaged to conduct the audit. Thus, apart from assessing the documents and the (energy) performance, effectiveness can be evaluated through additional appraisal interviews or by observing company processes.

If the auditors approve the compliance of the management system with the requirements of ISO 50001, the company is awarded the certificate.

#### **RE-CERTIFICATION**

To ensure the continuous improvement of the EnMS, the certifier conducts annual audits. Performance is thus systematically assessed, enhanced and optimised as necessary. Nonconformities can therefore be detected at an early stage and relevant corrective measures taken.

Recertification of management systems requires a regular review audit by the certifier. Remember to conduct the re-certification before the existing certificate expires. As previously mentioned, certification expires after three years, but it may also be withdrawn after one year when poor results are achieved in terms of the energy targets.

#### **COMMUNICATION OF CERTIFICATE**

The certificate signifies to your employees, business partners, clients and the broader public that your company has successfully implemented an EnMS. Various internal and external communication tools are available to communicate this achievement. Thus, it is possible; for example, to include the EnMS in the company's annual or sustainability reports. It is further

recommended to define target groups, identify communication media (like newsletters, professional journals, events, company website, et cetera) and develop corresponding marketing strategies.

According to DIN EN ISO 50001:2011, external communication is not obligatory following a certification but remains the decision of each company. If a company decides against external communication, it should be able to supply reasons for this decision. External communication is generally recommended as an opportunity to highlight the credibility of the company's energy policy.

### ***ENERGY PERFORMANCE AUDITING VERSUS ENERGY MANAGEMENT SYSTEMS (EnMS)***

The sensor and measuring industry has advanced tremendously in the last 15 years. For almost any physical, electrical or chemical parameter required to appraise the energy performance of a process there is a sensor available. Sensors, are becoming smaller, smarter and cheaper at a fast pace. Nevertheless the hardware and software investment for an intelligent EnMS is high to very high and a barrier to be reckoned with. Often extensive wiring is also necessary to link sensors and meters to the EnMS computer system. The more energy consumers in a factory are monitored the more complex becomes the analytical software. See section 3.2.2 for detailed explanation on differences.



### 3. ENERGY EFFICIENCY IN INDUSTRIES: THERMAL PROCESSES

#### *About this module*

Thermal processes are central to industrial activities. This module introduces trainees to the operational principles of common thermal processes. Trainees are then familiarised with common losses and necessary calculations for adequate analysis.

#### *Learning outcomes*

At the end of this module, the participant is able to

- Describe operational principles of common industrial thermal processes
- Use the respective tools and instruments
- Calculate energy losses
- Conceive, analyse and recommend energy conservation measures
- Prepare, present and defend proposals
- Implement measures

The industrial sector encompasses numerous entities engaged in manufacturing, agriculture, forestry, construction, and mining. These industries require energy primarily for electric drives, electrochemical processes, lighting, refrigeration, heating, cooling and ventilation facilities (energy applications geared towards user comfort). Using this energy efficiently is necessary to keep industries competitive, clean, and operating at peak productivity. Energy management programs that improve operational and technological efficiency are critical to the long-term success of industry and manufacturing.

In the industrial sector, the process industry is the largest energy consumer in its processing of bulk resources such as petroleum, chemicals, and primary metals; pulp and paper; food and beverages; stone, clay and glass. Good energy management practices and energy-efficient equipment can bring about appreciable reductions in industrial consumption.

#### **3.1. FUELS AND COMBUSTION**

In Nigeria fossil fuels dominate the primary energy supply and are mainly used for power generation and transport. In contrast to many other countries which rely on fossil fuels for heating, wood is the main heating fuel in Nigeria, along with being a renewable energy source. Using electricity for heating is generally not recommended for economic reasons. The only exceptions are electricity used for heat pumps and for decentralised hot water preparation. With an eye toward impending climate change, electricity should also be used even for heating in the future – yet it must be sourced exclusively from renewable energies such as wind power and solar photovoltaics.

The main problems with fuels occur because:

- Once a heating system is installed, fuels may rarely be changed.
- Fossil fuels are environmentally damaging due to their emissions.
- Many countries have to import fossil fuels and the dependency on foreign markets and prices carry large risks. Nigeria, however, belongs to the ten biggest net exporters of crude oil and natural gas worldwide.

When comparing fuels, it is necessary to create a common standard for comparison. This should be the energy available to the user in kWh. The calorific value of each fuel and the efficiency of fuel-fired equipment should be considered when comparing the useful energy available to a company.

Boilers as well as furnaces utilise fuel combustion to convert chemical energy in fuels into thermal energy or heat. In addition to fuel, combustion equipment requires an input of oxygen from combustion air. The result is a hot gaseous mixture that includes water vapour. Process heat is extracted from the gaseous mixture:

- Directly as often occurs in a furnace or kiln, or
- Indirectly with steam or hot water in a boiler.

### **SOURCES OF FUELS – FOCUS ON WOOD**

#### **» Wood as a renewable fuel**

Wood is an energy source which regenerates through photosynthesis. The reasonable use of wood will neither destroy nor harm our environmental legacy to future generations. It enables the conservation of fossil energy sources (petroleum, natural gas, coal, uranium), which are available only in finite and unevenly distributed quantities throughout the world. Wood can be replenished much more quickly than other energy sources.

Although wood is a renewable fuel, it is still rare in some areas in the world like parts of Africa. The destructive exploitation of global rainforests is a severe problem that is accelerating world-wide climate change.

## **3.2. BOILERS**

### **BOILERS AND HEATING SYSTEMS FOR SMALL AND MEDIUM SIZED COMPANIES**

Boilers are used to generate steam. They can be fuelled by gas, oil or coal, and may be fully or partially fuelled from waste heat. The two main types of boilers are *firetube* and *watertube*. These terms refer to the construction of the heat exchangers built into the boiler. In firetube boilers, hot combustion gasses pushed through tubes that are immersed in the boiler water. In watertube boilers, heat exchange is done in the opposite way; water pushed through tubes that reside in the combustion chamber.



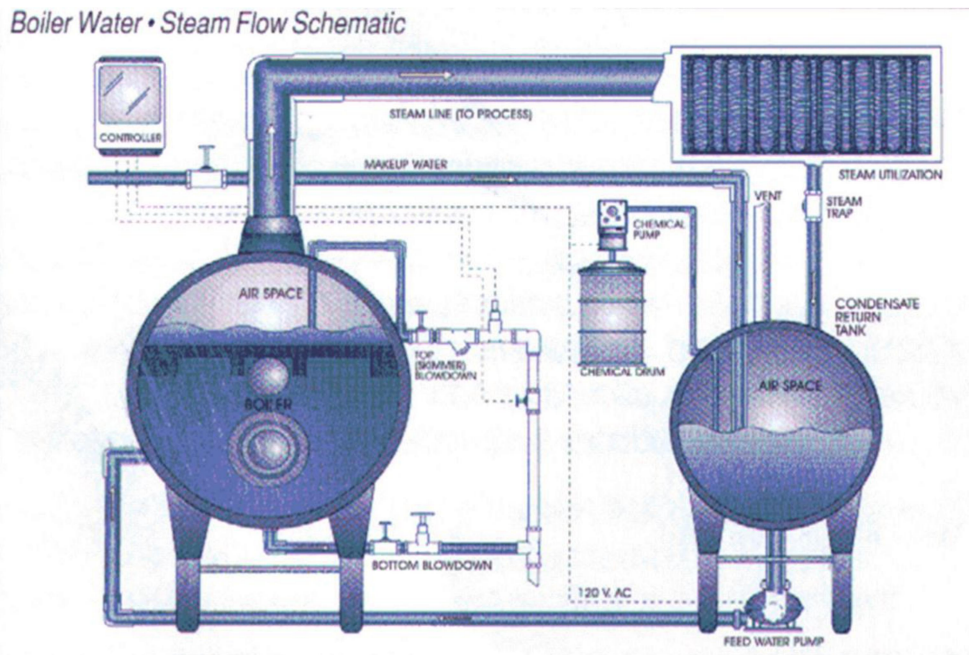

Figure 3.1: Steam boiler setup

#### » Boiler efficiency

The efficiency of a boiler is a product of the fuel combustion efficiency and heat exchange efficiency. The overall boiler efficiency is defined as:

$$\text{Boiler efficiency} = \frac{\text{steam energy}}{\text{fuel energy}} \times 100$$

There are always two types of boiler efficiency sought in the procurement and tender of boilers. Efficiency is based either on the higher heating value (HHV) or on the lower heating value (LHV) of the fuel. The difference can be up to 4 percentage points.

The HHV (also known gross calorific value or gross energy) of a fuel is defined as the amount of heat released by a specified quantity (initially at 25°C) once it is combusted and the products have returned to a temperature of 25°C, which takes into account the latent heat of water vaporisation in the combustion products.

The LHV (also known as net calorific value) of a fuel is defined as the amount of heat released by combusting a specified quantity (initially at 25°C) and returning the temperature of the combustion products to 150°C, which assumes the latent heat of water vaporisation in the reaction products is not recovered.

#### PERFORMANCE EVALUATION OF BOILERS

There are two methods of assessing boiler efficiency.

1. **Direct method:** Where the energy gain of the working fluid (water and steam) is compared with the energy content of the boiler fuel.

$$\text{Boiler efficiency } (\eta) = \frac{Q \times (H - h)}{(q \times \text{GCV})} \times 100$$

Where,  $Q$  = Quantity of steam generated per hour (kg/h)  
 $H$  = Enthalpy of saturated steam (kJ/kg)  
 $h$  = Enthalpy of feed water (kJ/kg)  
 $q$  = Quantity of fuel used per hour (kg/h)  
 GCV = Gross calorific value of the fuel (kJ/kg)

2. **Indirect method:** Where the efficiency is the difference between the losses and the energy input.

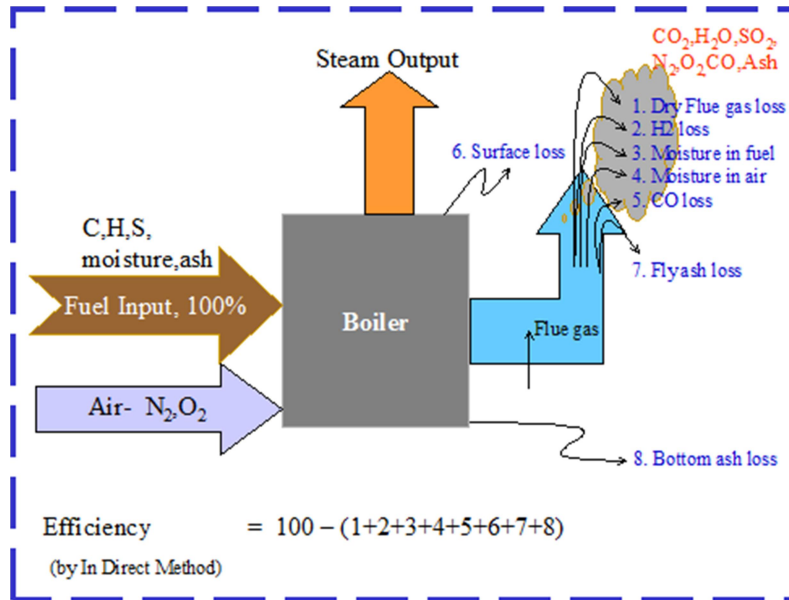

Figure 3.2: Boiler efficiency calculation by indirect method

### Example 1: Boiler efficiency calculation – indirect method

The indirect method is best explained by the following example:

Below are data collected for a typical oil-fired boiler. Calculate the efficiency of the boiler using the indirect method and the boiler evaporation ratio.

Ultimate analysis of oil : C: 84.0%, H<sub>2</sub>: 12.0%, S: 3.0%, O<sub>2</sub>: 1.0%

GCV of oil : 42,677 kJ/kg

Steam generation pressure : 7kg/cm<sup>2</sup>(g)-saturated

Enthalpy of steam : 2,761 kJ/kg

Feed water temperature : 60°C (251 kJ/kg)

Percentage of O<sub>2</sub> in flue gas : 7% Percentage of CO<sub>2</sub> in flue gas: 11% Flue gas temperature (T<sub>i</sub>): 220°C  
 Ambient temperature (T<sub>a</sub>): 27°C

Humidity of air: 0.018 kg/kg of dry air, specific heat of flue gas = 1.097 kJ/kgK, specific heat of super-heated steam = 1.996 kJ/kgK, latent heat corresponding to the partial pressure of water vapour = 2,443 kJ/kg

**Solution:**

**Step 1: Find the theoretical air requirement.**

$$[(11.6 \times C) + \{34.8 \times (H_2 - O_2/8)\} + (4.35 \times S)]/100 = \text{kg/kg of oil}$$

$$= [(11.6 \times 84) + \{34.8 \times (12 - 1/8)\} + (4.35 \times 3)]/100 \text{ kg/kg of oil}$$

$$= 14 \text{ kg of air/kg of oil}$$

**Step 2: Find the % of excess air supplied.**

$$\text{Excess air supplied (EA)} = \frac{O_2\%}{21-O_2\%} \times 100 = \frac{7\%}{21-O_2\%} \times 100 = 50\%$$

**Step 3: Find the actual mass of air supplied.**

**Actual mass of air supplied / kg of fuel** = [ 1 + EA/100] x theoretical air

$$\text{(AAS)} = [1 + 50/100] \times 14 = 1.5 \times 14 = 21 \text{ kg of air/kg of oil}$$

**Step 4: Estimate all losses.**

i. **Dry flue gas loss**

$$\text{Percentage heat loss due to dry flue gas} = \frac{m \times C_p \times (T_f - T_a)}{\text{GCV of fuel}} \times 100$$

Total mass of flue gas (m) = mass of actual air supplied + mass of fuel supplied

Now mass of air = mass of CO<sub>2</sub> + mass of SO<sub>2</sub> + mass of N<sub>2</sub> + mass of O<sub>2</sub>

$$\frac{0.84 \times 44}{12} + \frac{0.03 \times 64}{32} + \frac{21 \times 77}{100} + \left( (21 - 14) \times \frac{23}{100} \right) = 21 \text{ kg / kg of oil}$$

Total mass of flue gas (m) = 21+1 = 22

$$\text{Percentage heat loss due to dry flue gas} = \frac{22 \times 1.097 \times (220 - 27)}{42677} \times 100 = 10.91 \%$$

ii. **Heat loss due to evaporation of water formed due to H<sub>2</sub> in fuel**

$$= \frac{9 \times H_2 \times \{2443 + C_p(T_f - T_a)\}/100}{\text{GCV of fuel}} \times 100$$

Where, H<sub>2</sub> – percentage of H<sub>2</sub> in fuel

$$= \frac{9 \times H_2 \times \{2443 + 1.996(220 - 27)\}/100}{42677} \times 100 = 7.16\%$$

iii. **Heat loss due to moisture present in air**

$$= \frac{\text{AAS} \times \text{humidity} \times C_p(T_f - T_a)}{\text{GCV of fuel}} \times 100$$

$$= \frac{21 \times 0.018 \times 1.996 \times (220 - 27)}{42677} \times 100 = 0.34$$

iv. **Heat loss due to radiation and other unaccounted losses**

For a small boiler this loss is estimated at 2%.

$$\text{Boiler efficiency} = 100 - [10.91 + 7.16 + 0.34 + 2]$$

$$= 100 - 20.41 = 79.6 \text{ (app)}$$

Evaporation ratio = Heat utilised for steam generation/heat addition to the steam

$$= 42677 \times 0.796 / (2761 - 251) = 33971/2510 = 13.51 \text{ kg of steam/kg of oil}$$

» **Boiler blowdown**

**What causes boiler blowdown?**

When water evaporates, dissolved solids become concentrated and precipitate in tubes. This reduces the heat transfer rate.

**INTERMITTENT BLOWDOWN**

Intermittent blowdown can be regulated by manually operating a valve fitted to the discharge pipe at the lowest point of the boiler shell to reduce parameters (Total dissolved solids (TDS) or conductivity, pH, silica, etc.) within prescribed limits so that steam quality is not likely to be affected.

**CONTINUOUS BLOWDOWN**

Steady and constant dispatch of a small stream of concentrated boiler water, and replacement by a steady and constant inflow of feed water. This ensures constant total dissolved liquids (TDS) and steam purity. This type of blowdown is common in high-pressure boilers.

Energy efficiency measures in boiler and heat distribution systems:

- Use an optimum fuel-air mixture to improve the boiler’s combustion efficiency.
- Insulate steam distribution and condensate return lines.
- Return condensate to the boiler to minimise boiler blowdown; as more condensate is returned, less makeup water is required, saving fuel, makeup water, chemicals and treatment costs.
- Use automatic blowdown control and change process steam requirements to reduce steam demand.

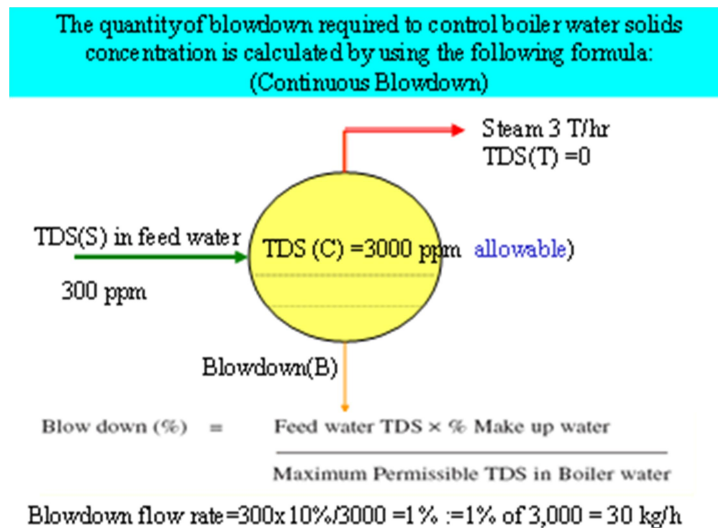

Figure 3.3: Continuous blowdown formula

- Implement a steam trap maintenance program.
- Install removable insulation on valves and fittings to check leaks.
- Clean the heat exchanger and boiler to remove the sediment and scale layer that insulates the boiler heat exchange tubes.
- Correct boiler sizing. Select boiler sizes to match varying demand. A small boiler could be installed to operate at close-to-full load for periods of low demand; one or two larger boilers could handle peak loads.

- Replace furnaces or boilers that are old, worn out, inefficient, or significantly oversized, with modern high-efficiency models.

» **Economisers**

Flue gases from large boilers are typically  $-230$  to  $350^{\circ}\text{C}$ . So-called economisers recover some of this heat for pre-heating water. The water is most often used for boiler makeup water or some other need that coincides with boiler operation. Economisers can be considered as an efficiency measure when large amounts of makeup water are used. As an alternative, boilers can also be retrofitted with an economiser at a later time as shown below.

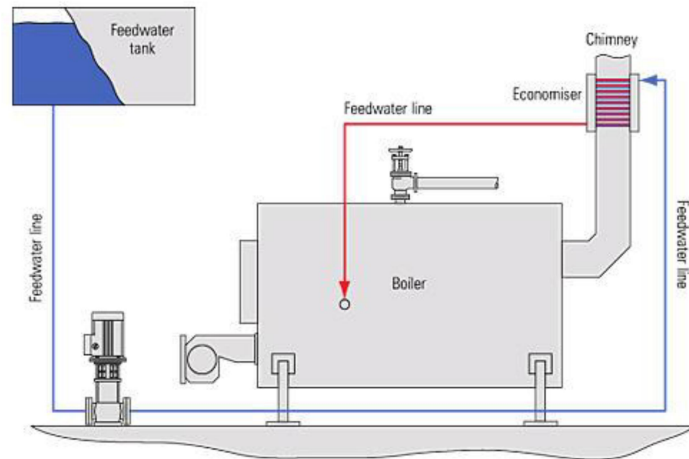

Figure 3.4: Boiler economiser principle

### ENERGY PERFORMANCE AUDITING VS. ENERGY MANAGEMENT OF A BOILER SYSTEM

EnMS is a buzz word and subject to a number of interpretations. The software and hardware features of an industrial EnMS monitoring and controlling a steam boiler system are explained in detail in this section.

The approach will demonstrate that sophisticated EnMS hardware and software operated by an Energy Manager (EM) and his/her team have and will more and more in the future replace the services of an Energy Auditor (EA). The EnMS will also be capable of analysing the energy performance of a process, equipment or an entire industrial plant in a much more sophisticated way a human being without an EnMS would be able to do provided it is connected to a number of sensors.

Hardware and software of an industrial EnMS is only one part of the EnMS. However it is the most important part that delivers at the end of the day the analytical results needed to reduce energy losses in a cost effective way.

Figure 3.5 shows a boiler featuring already by design, two EMOs that utilise some of the waste heat of the stack and the boiler blowdown:

- a) The **economiser (2)**. It uses high stack gas temperatures to recover waste heat by pre-heating the boiler feed water (7+8).
- b) The boiler **surface blowdown (5)**. This is a source of waste heat that is used to preheat the makeup water for the boiler.

Imagine this boiler would become part of a perfect industrial EnMS. In reality it means the Energy Manager could in his office on the displays of the EnMS computer observe the energy and financial performance of this boiler at any instance of time. Such almost perfect software and hardware packages are state-of-the-art for larger boilers and not only for boilers but also for chillers, pumps, blowers, steam distribution systems, compressors, and furnaces of all types. A boiler system is taken as an example since it combines physical, chemical and elec-

trical parameters that need to be measured and recorded either at any instance of time or periodically.

The associated software will take this steady flood of data and analyse it in such a way that combined with cost data for fuel, electricity and water, and fuel properties (C, H, S, O, H<sub>2</sub>O) which the EM must provide, it will calculate and display the fractional cost of fuel energy, electricity and water in USD/ton of steam supplied to the steam distribution network.

In addition the software will point out the set of performance parameters, called a system performance scenario, at which the boiler system generated the steam at the lowest fuel consumption. At this point we briefly summarise:

- i. Technology or process specific industrial EnMS packages are available on the market;
- ii. The EnMS package comes with hardware of many sensors and meters including wiring and a software package that models the **energy and financial** performance of the technology or process in question;
- iii. In addition to the data flow provided by sensors, the Energy Manager of the company must provide fuel, electricity and water supply cost data as well as facility depreciation cost to let the EnMS calculate an interdepartmental steam transfer price in USD per ton of steam at any instance of time;
- iv. EnMS is analysing the flood of data by algebraic, statistical and heuristic data analysis means to determine the two operational scenarios at which the system either generated a ton of steam at the lowest specific energy consumption, or the lowest energy and operational costs. Both operational scenarios may not be identical;
- v. An EnMS package for large boilers is by far more analytical and takes many more process performance parameters into consideration than an Energy Auditor and his mobile measuring equipment could ever consider. More and more Energy Managers backed up by EnMS will become qualified Energy Auditors without a need to fully understand the process of steam generation and associated technologies;
- vi. An EnMS however cannot prevent a company from making an irreversible investment error. The EM must be specially trained in this topic.



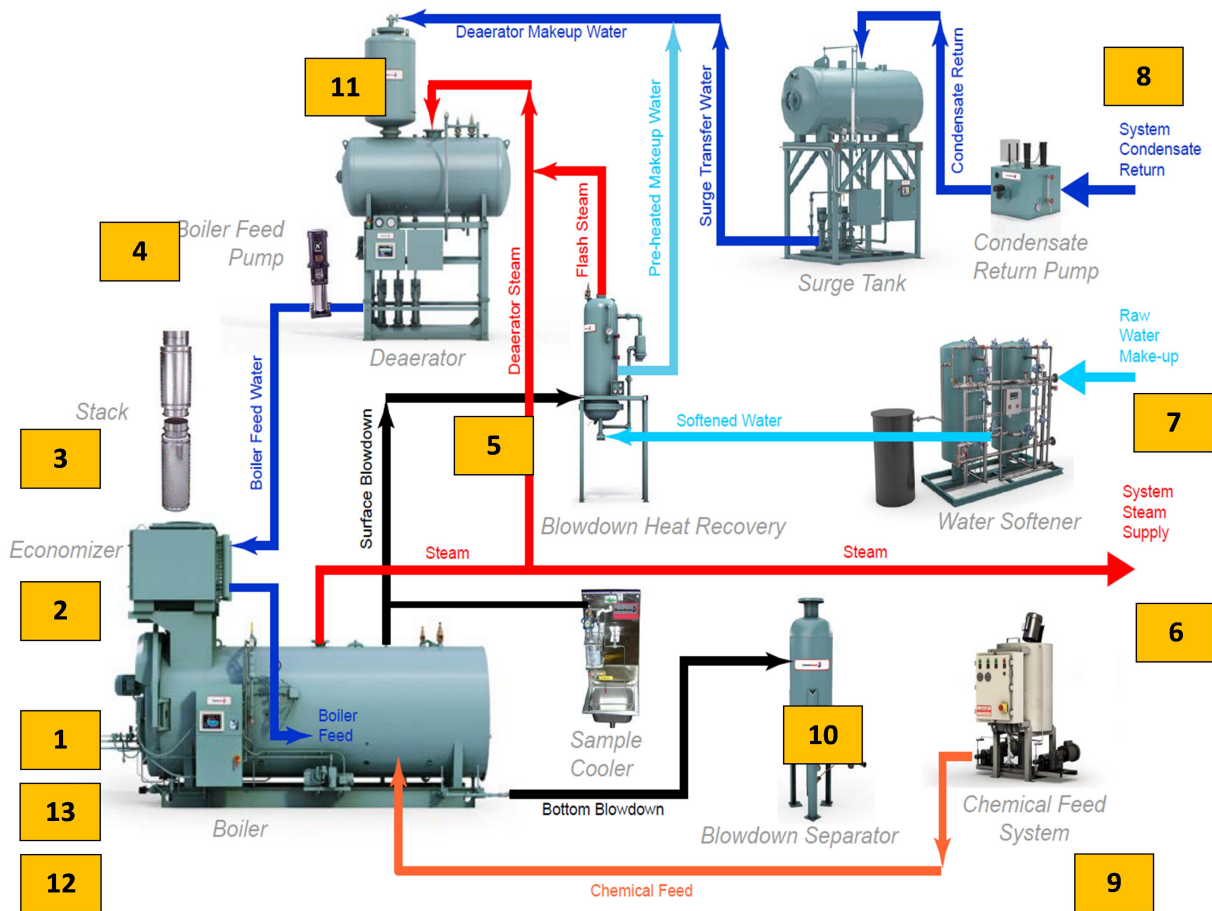

Figure 3.5: Boiler components and hot and cold energy streams – Courtesy: [www.econtrol.com](http://www.econtrol.com)

» Listing the system performance parameters and associated sensors

This section discusses the boiler system performance parameters that could be in principle monitored by a perfect EnMS system. The list serves as a reminder that the more parameters are covered by an EnMS software the more in-situ sensors must be installed and the more expensive the hardware part of the EnMS becomes.

Table 3.1: Feasible steam boiler performance measurement parameters

No	Boiler component	Sensors and exemplary units	Used by
1	Fuel supply system (gas or oil)	- Volume flow (m <sup>3</sup> /period) - Fuel oil temperature (°C)	EnMS EnMS
2	Economizer (Heat exchanger, HE)	- Velocity stack gas (m/sec) - Temperature stack gas in (°C) - Temperature stack gas out (°C) - Feed water temperature in (°C) - Feed water temperature out (°C)	None EnMS EnMS EnMS EnMS
3	Stack gas	- Oxygen content (%v wet basis) - CO (ppm wet or dry) - Pressure drop across HE (mbar)	EA EA EnMS
4	Boiler feed water pump	- Currents (Ampere) - Volume flow (m <sup>3</sup> /period) - Pressure drop (Δbar)	EA EnMS EnMS

No	Boiler component	Sensors and exemplary units	Used by
5	Surface blow down	- Volume flow(m <sup>3</sup> /period) - Temperature (°C)	EnMS EA
6	Life steam flow	- Volume flow(m <sup>3</sup> /period) - Pressure (bar) - Temperature (°C) - Dryness fraction	EnMS EA EnMS None
7	Raw water make up in water softener and preheating in flash tank	- Volume flow (m <sup>3</sup> /period) - Water hardness ( pH value) - Temperature in (° C) - Temperature after preheater out (°C)	EnMS EA EA EA
8	System condensate return pump	- Volume flow (m <sup>3</sup> /period) - Pressure drop (Δbar) - Temperature return (°C)	EnMS EnMS EA
9	Chemical feed	- Various parameters	None
10	Bottom blow down	- Volume flow (m <sup>3</sup> /period) - Temperature (°C)	EnMS EA
11	Deaerator system	- Steam volume flow (m <sup>3</sup> /period) - Steam temperature (°C)	EnMS EA
12	Boiler room ambient air	- Temperature (°C) - Relative humidity (% rH)	EA EA
13	Boiler forced air blower	- Volume flow (m <sup>3</sup> /period) - Pressure drop (Δbar) - Current (Ampere)	None EnMS EA

In the above case the perfect boiler EnMS is a system of about 36 sensors feeding the EnMS software with data. The EM adds to this data boiler depreciation, fuel, water and chemical costs together with the ultimate chemical and proximate analysis of the fuel. For illustrations of sensors and instrumentation see [www.lesman.com/catupdates.html](http://www.lesman.com/catupdates.html) to get an idea about costs and appearance of the gadgets.

An EA well equipped with measuring equipment and having access to measuring points prepared for him by the EM and his team, which is not always the case, may be able to measure at most 15 performance parameters. Volume and pressure measurements are intrusive. The EnMS software solves the equation matrix; call it the mathematical kernel of the boiler model for 36 parameters to obtain the desired results and much more. The EA calculates by hand, or Excel spreadsheet, or is using handheld measurement instrumentation that do cruder calculations. Typical examples are handheld fuel combustion analyzers used for boilers and furnace efficiency determinations.

Two important additional features of an EnMS are worthwhile to mention. Some EnMS also monitor preventive maintenance parameters saving a company significant down time costs. A typical example is vibration and temperature sensors mounted on larger industrial blowers that warn of impending blower outages and a need to rebalance or even replace the blower.

A second typical example is pressure drop sensors ( $\Delta p$ ) installed in steam and air duct and piping systems. Increased pressure drops caused by plugged filters, pipe fouling and unnecessary duct system obstructions are main reasons of higher than necessary power consumption of pumps and blowers.

Another, for plant staff often embarrassing feature of an EnMS, is its ability to detect questionable performance data recorded by the plant staff and malfunctioning sensors. Software based mathematical models verifying the performance of a boiler, or motor-blower-duct system or an entire coal fired power plant without the need of sensor inputs have been on the market for 30 years. These “EnMS **minus** sensors” systems, call it EnMS (lite), are still today a useful tool for an EA.

A typical example is the sophisticated models for thermal power plants to identify energy saving opportunities, detect design anomalies and operational inefficiencies without even visiting the power plant. EnMS (lite) software is also used by an EA to appraise the performance details and guaranteed design efficiencies as part of a tendering process. It is not so unusual that the “heat rate” i.e. the specific fuel energy consumption of power plants is cited too low.

For instance, an EA specialized on thermal combustion equipment can with the help of software identify questionable sensor signals, or doubtful operational data, or false claims in engineering procurement and construction documents (EPC).

Finally, in these days of inexpensive terrestrial or satellite based mobile telecommunication reaching almost any corner of this earth, the energy performance monitoring feature of an EnMS is also outsourced to third parties. Consultants watch the plant performance from a distance and provide independent advice concerning reduction of technical energy losses and deviation from normal operation parameters for thermal power plants or power transmission and distribution systems.

### 3.3. STEAM SYSTEMS

#### OPTIMISING STEAM / CONDENSATE SYSTEMS

Steam is commonly used as the medium to distribute heat from the boiler to its end-use point. The same characteristics that make it useful as a transport medium (high heat carrying capacity) also make its distribution system more susceptible to energy loss and waste. Steam supply and condensate return systems require regular inspection and maintenance in order to minimise or eliminate these losses.

After steam is generated at a boiler, it is delivered under pressure to the load by the *steam distribution system*. Typically, the latent heat in the steam is converted in a heat exchanger and the steam is condensed (returned to a liquid state). This hot *condensate* is returned via the *condensate return system* to the boiler makeup water to be reheated and repeat the cycle. In some cases, live steam is injected directly into the process, in which case no condensate is returned.

Steam systems can be classified by pressure; condensate systems by their return method (gravity or pumping). Because of the inherent danger in pressurised steam systems, regulations on system modifications are usually quite stringent. Any energy management opportunity (EMOs) requiring piping or equipment changes must be designed, implemented and inspected by qualified personnel.

In summary, optimising a steam/condensate system involves three actions: generating the steam, distributing the steam, and returning the condensate to the boiler as energy efficiently as possible. Steam leaks are a common source of energy loss, including steam traps that are stuck open and poorly insulated or uninsulated pipes. The non-contact (infrared) thermome-

ter is a useful tool for tracking down steam leaks in steam and condensate systems. One by-product of an optimised steam/condensate system is a reduction in water treatment chemicals – returned condensate not only contains heat energy but also valuable treatment chemicals.

» **Steam table excerpt**

Because of its importance as a means of moving energy in a plant, it is necessary to have ready access to steam property data. Traditionally this information is provided in steam tables, which you can find on the Internet with an online calculator for steam properties:

1. <https://ecenter.ee.doe.gov/EM/tools/Pages/SteamSystemCalculators.aspx>
2. [www.tlv.com/global/TT/calculator/steam-flow-rate-through-piping.html](http://www.tlv.com/global/TT/calculator/steam-flow-rate-through-piping.html)

Table 3.2: Reproduction of a steam table excerpt

Absolute pressure (kN/m <sup>2</sup> )	Temperature (°C)	Specific volume (m <sup>3</sup> /kg)	Density - ρ - (kg/m <sup>3</sup> )	Specific enthalpy of			Specific entropy of steam - s - (kJ/kgK)
				Liquid - h <sub>l</sub> - (kJ/kg)	Evaporation - h <sub>e</sub> - (kJ/kg)	Steam - h <sub>s</sub> - (kJ/kg)	
0.8	3.8	160	0.00626	15.8	2,493	2,509	9.058
2.0	17.5	67.0	0.0149	73.5	2,460	2,534	8.725
5.0	32.9	28.2	0.0354	137.8	2,424	2,562	8.396
10.0	45.8	14.7	0.0682	191.8	2,393	2,585	8.151
20.0	60.1	7.65	0.131	251.5	2,358	2,610	7.909
28	67.5	5.58	0.179	282.7	2,340	2,623	7.793
35	72.7	4.53	0.221	304.3	2,327	2,632	7.717
45	78.7	3.58	0.279	329.6	2,312	2,642	7.631
55	83.7	2.96	0.338	350.6	2,299	2,650	7.562
65	88.0	2.53	0.395	368.6	2,288	2,657	7.506

» **Flash steam recovery**

Flash steam is produced when high-pressure condensate is released to a lower pressure zone and can be used for low-pressure heating.

$$\text{Flash steam available in \%} = \frac{S_1 - S_2}{L_2} \times 100$$

- Where,
- S<sub>1</sub> = Is the sensible heat of higher pressure condensate.
  - S<sub>2</sub> = Is the sensible heat of the steam at a lower pressure (at which it has been flashed).
  - L<sub>2</sub> = Is the latent heat of flash steam (at lower pressure).

**Example 2: Calculating the amount of flash steam from condensate**

Hot condensate at 7 bar g has a heat content of about 721 kJ/kg. When it is released to atmospheric pressure (0 bar g), each kilogram of water can only retain about 419 kJ of heat. The excess energy in each kilogram of the condensate is therefore  $721 - 419 = 302$  kJ. This excess energy is available to evaporate some of the condensate into steam, the amount evaporated being determined by the proportion of excess heat to the amount of heat required to evaporate water at the lower pressure, which, in this example, is the enthalpy of evaporation at atmospheric pressure, 2,258 kJ/kg.

$$\text{Flash steam available in \%} = \frac{(721 - 419)}{2,258} \times 100 = 13.4 \%$$

**SOME USEFUL ENERGY CONSERVATION TIPS****Boilers**

- 5% reduction in excess air increases boiler efficiency by 1% (or: 1% reduction of residual oxygen in stack gas increases boiler efficiency by 1%).
- 22°C reduction in flue gas temperature increases boiler efficiency by 1%.
- 6°C increase in feed water temperature by economiser or condensate recovery corresponds to a 1% saving in fuel consumption, in the boiler.
- 20°C increase in pre-heated combustion air temperature by waste heat recovery results in a 1% fuel savings.
- A 3 mm layer of soot on the heat transfer surface can increase fuel consumption to the tune of 2.5%.
- A 1 mm layer of scale (deposit) on the water side could increase fuel consumption by 5 to 8%.

**Steam**

- Insulation should be designed such that the exterior temperature of the steam carrying pipeline is no more than 20°C above the ambient temperature.
- A bare steam pipe measuring 150 mm in diameter and 100 m in length and carrying saturated steam at 8 kg/cm<sup>2</sup> would waste 25,000 litres of furnace oil in one year.
- For indirect heating, keep pressure to a minimum, as steam has a higher latent heat.

The above tips are intended to help you appreciate different possibilities for energy savings. Energy Managers or auditors have the task of calculating actual savings based on fundamental data and relations.

**3.4. FURNACES****» Types of furnaces**

Furnaces are by definition heating devices and therefore energy consumers. Furnace systems can be divided into batch furnaces (stationary heating) and continuous furnaces (large heat output at regular intervals). Batch furnaces include box furnaces, cover furnaces, etc. Continuous furnaces are generally used for mass production. This furnace category includes pusher furnaces, walking hearth furnaces, rotary hearth and walking beam furnaces. The primary energy required for reheating or heat treatment (in, say, annealing) furnaces occurs in the form of natural gas, furnace oil, LSHS, LDO or electricity.

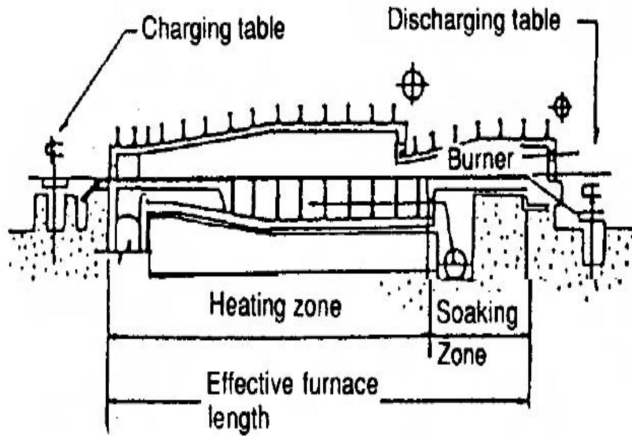

Figure 3.7: Three-zone reheating pusher furnace

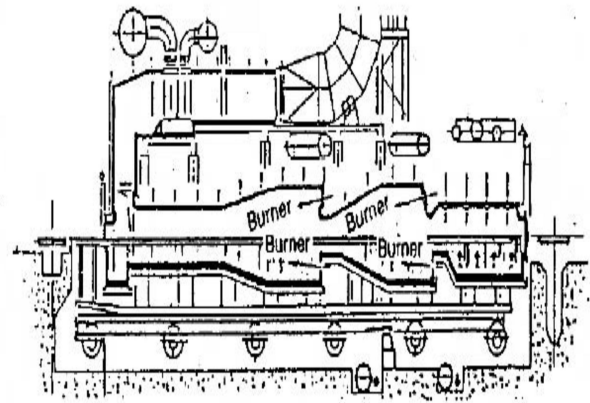

Figure 3.6: Walking beam reheating furnace

All non-electric furnaces utilise a burner to deliver a mixture of fuel and air for the combustion process that produces heat, which is subsequently transferred to the product either directly (within the combustion chamber) or indirectly (through a heat exchanger). Electrical energy may also be used to operate auxiliary equipment such as blowers or draft fans.

As with boilers it is important to evaluate furnace performance and efficiency over the entire range of actual or partial loads. Unlike boiler systems, furnaces are not usually integrated in a large heating distribution system with accompanying losses (i.e. the end use of the heat is within the furnace).

Maintaining the optimum ratio of fuel to air is critical to the efficient operation of fuel burning furnaces. A lack of air leads to incomplete combustion, resulting in losses of combustibles in the flue gases (smoky flame). Excess air needlessly increases the dry flue gas losses, as indicated by increased temperature of the flue gas. In addition, the excess air entering the furnace must be heated, thus increasing energy loss. The temperature of the flue gas also depends on the effectiveness of heat transfer to the product being processed, and is a good indicator of the condition of internal heat transfer surfaces. In some cases, a large amount of excess air is required to maintain the product quality. If this condition applies, then heat recovery should be considered. Portable combustion analysers are useful tools in gauging the combustion efficiency of process furnaces, dryers and kilns. More information about different analyser types can be found at:

1. [www.testo350.com/](http://www.testo350.com/)
2. [www.mybacharach.com/product-view/pca3/](http://www.mybacharach.com/product-view/pca3/)
3. [www.e-inst.com/industrial-gas-analyzers/products-E4500](http://www.e-inst.com/industrial-gas-analyzers/products-E4500)



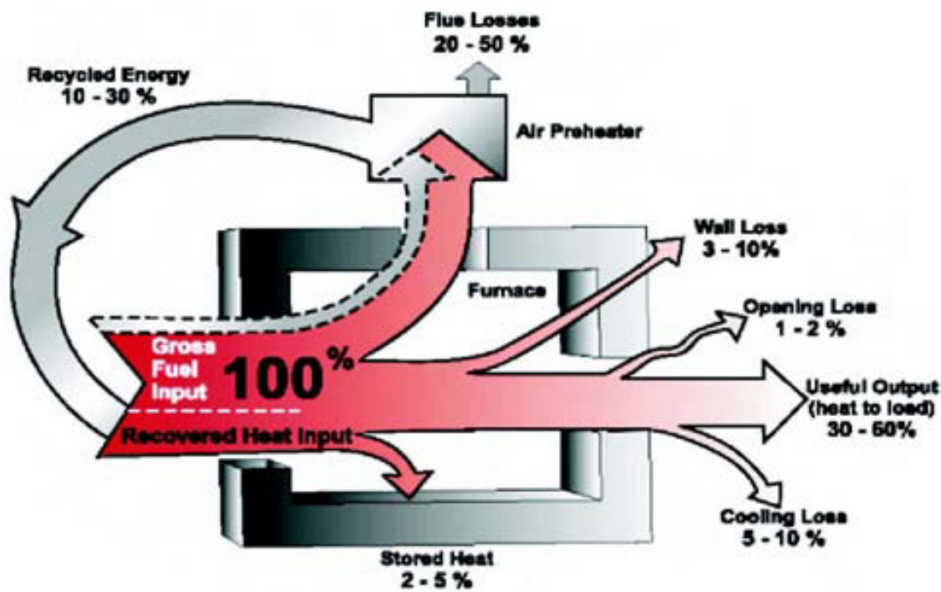

Figure 3.8: Fuel-fired furnace

#### Purposes of the performance test:

- To determine furnace efficiency
- To calculate specific energy consumption

The performance test is conducted to determine efficiency of the furnace and the specific energy consumption for a comparison with design values or best practice standards. There are many factors affecting furnace performance such as the capacity utilisation of furnaces, excess air ratio, final heating temperature, etc. This indicator is essential to assess the current performance level and determine the scope for improvements and enhanced productivity.

#### » Heat balance of a furnace

Heat balance helps us to numerically understand the present heat loss and efficiency value and improve the furnace operation using these data. Thus, preparation of heat balance is a pre-requirement for assessing energy conservation potential.

Normally with furnaces we would, as described, obtain specific energy consumption (SEC) data from the Energy Manager before looking into the thermal balance of the kiln. There is a wide range of permissible SEC values, for instance:

- Fuel oil consumption ranging from 32 to 98 l/tonne of steel in a reheating furnace,
- or 680 to 1050 kCal/kg of clinker in cement plants,
- or 890 kcal to 5200 kCal/kg for earthenware and porcelain.

#### » Performance terms and definitions

Furnace efficiency, %

$$= \frac{\text{Heat output}}{\text{Heat input}} \times 100$$

$$= \frac{\text{Heat in stock (material) (kCal)}}{\text{Heat in fuel / electricity (kCal)}} \times 100$$

### Specific energy consumption

$$= \frac{\text{Quantity of fuel or energy consumed}}{\text{Quantity of material processed}}$$

#### » Test method for furnace efficiency

The energy required to increase the temperature of a material is the product of the material mass, the change in temperature and the specific heat, i.e.

$$\text{Energy} = \text{mass} \times \text{specific heat} \times \text{rise in temperature}$$

Reference manuals can be used to obtain the specific heat of various materials. Specific heat describes the amount of energy required to raise one unit of mass by one degree Celsius.

If, moreover, the process requires a change in state, either from solid to liquid or from liquid to gas, then additional energy is required. This energy quantity is called the latent heat of fusion or latent heat of evaporation and it needs to be added to the total energy requirement. In this section, however, melting furnaces, to which this energy applies, are not considered.

The total heat input is provided in the form of fuel or power. The desired output is the heat supplied for heating the material or process. Other heat outputs in furnaces are undesirable heat losses. Losses occurring in fuel-fired furnaces include:

- Heat loss through exhaust gases, either as sensible heat, latent heat or as incomplete combustion
- Heat loss through the furnace walls and hearth
- Heat loss to the surroundings by radiation and convection from the outer surface of the walls
- Heat loss through gases leaking through cracks, openings and doors.

The efficiency of a furnace is the ratio of useful output to heat input. Furnace efficiency can be determined by both direct and indirect testing.

#### DIRECT EFFICIENCY TEST

The efficiency of furnace can be assessed by measuring the amount of heat added to the stock and the heat in the fuel consumed, on a batch/day basis as relevant

$$\text{Thermal efficiency of the furnace} = \frac{\text{Heat in the stock}}{\text{Heat in the fuel consumed}}$$

The quantity of heat to be imparted (Q) to the stock can be found using the formula

$$Q = m \times C_p (t_2 - t_1)$$

- Where,
- Q = Quantity of heat in kCal
  - M = Weight of the material in kg
  - C<sub>p</sub> = Mean specific heat in kCal/kg°C
  - t<sub>2</sub> = Final temperature desired in °C
  - t<sub>1</sub> = Initial temperature of the charge before it enters the furnace in °C

### INDIRECT EFFICIENCY TEST

Similar to the indirect method of evaluating efficiency for boilers, furnace efficiency can also be calculated using the indirect method. Furnace efficiency is calculated after subtracting sensible heat loss in flue gas, loss due to moisture in flue gas, heat loss due to openings in the furnace, heat loss through the furnace skin and other unaccounted losses from the input to the furnace. In order to determine furnace efficiency using the indirect method, various parameters are required: hourly furnace oil consumption, material output, excess air quantity, flue gas temperature, furnace temperature at various zones, skin temperature, and hot combustion air temperature. Efficiency is determined by subtracting all the heat losses from 100.

#### » *Measurement parameters*

The following measurements are to be taken when computing the energy balance in oil-fired reheating furnaces (e.g. heating furnace):

- Weight of stock / number of billets heated
- Temperature of furnace walls, roof, etc.
- Flue gas temperature
- Flue gas analysis
- Fuel oil consumption

Instruments like infrared thermometers, fuel consumption monitors, surface thermocouples and other measuring devices are required to measure the above parameters. Check reference manuals for data such as specific heat, humidity, etc.

#### *Example 3: Calculating energy efficiency using the indirect and direct methods*

An oil-fired reheating furnace has an operating temperature of around 1,340°C. The average fuel consumption is 400 litres per hour. The flue gas exit temperature downstream of the air preheater is 750°C. The preheater heats air from an ambient temperature of 40°C to 190°C. The thickness of the furnace wall (x) is 460 mm on the billet extraction outlet side, which is 1 metre high and 1 metre wide. The remaining data are given below. Find out the efficiency of the furnace using both the indirect and direct method.

Flue gas temperature after air preheater	750°C
Ambient temperature	40°C
Preheated air temperature	190°C
Specific gravity of oil	0.92
Average fuel oil consumption	400 litres/h $400 \times 0.92 = 368 \text{ kg/h}$
Calorific value of oil	10,000 kCal/kg
Average O <sub>2</sub> percentage in flue gas	12%
Weight of stock	6,000 kg/h
Specific heat of billet	0.12 kCal/kg/°C
Surface temperature of roof and side walls	122°C
Surface temperature outside heating and soaking zones	85°C

» Heat loss

**Example 3 (cont'd): Solution**

Sensible heat loss in flue gas

$$\text{Excess air} = \frac{O_2 \%}{21 - O_2 \%} \times 100$$

(Where O <sub>2</sub> is the % of oxygen in flue gas = 12%)	12 x 100 / (21 - 12) 133% excess air
Theoretical air required to burn 1 kg of oil	14 kg (typical value for all fuel oil)
Total air supplied	Theoretical air x (1 + excess air / 100)
Total air supplied	14 x 2.33 kg / kg of oil 32.62 kg / kg of oil
Sensible heat loss	m x C <sub>p</sub> x ΔT
m	Weight of flue gas Actual mass of air supplied / kg of fuel + mass of fuel (1 kg) 32.62 + 1.0 = 33.62 kg / kg of oil
C <sub>p</sub>	Specific heat of flue gas 0.24 kCal/kg/°C
ΔT	Temperature change
Heat loss = m x C <sub>p</sub> x ΔT	33.62 x 0.24 x (750 - 40) 5729 kCal / kg of oil

$$\% \text{ Heat loss in flue gas} = \frac{5729 \times 100}{10,000} = 57.29\%$$

**LOSS DUE TO EVAPORATION OF MOISTURE PRESENT IN FUEL**

**Example 3 (cont'd): Solution**

$$\% \text{ Loss} = \frac{M \{584 + 0.45 (T_{fg} - T_{amb})\}}{\text{GCV of fuel}} \times 100$$

Where

- M = kg of moisture in 1 kg of fuel oil (0.15 kg/kg of fuel oil)
- T<sub>fg</sub> = Flue gas temperature
- T<sub>amb</sub> = Ambient temperature
- GCV = Gross calorific value of fuel

$$\% \text{ Loss} = \frac{0.15 \{584 + 0.45 (750 - 40)\}}{10,000} \times 100 = 1.36\%$$

**LOSS DUE TO EVAPORATION OF WATER FORMED DUE TO HYDROGEN IN FUEL****Example 3 (cont'd): Solution**

$$\% \text{ Loss} = \frac{9 \times H_2 \{584 + 0.45 (T_{fg} - T_{amb})\}}{\text{GCV of fuel}} \times 100$$

Where,  $H_2$  – kg of  $H_2$  in 1 kg of fuel oil (0.1123 kg/kg of fuel oil)

$$= \frac{9 \times 0.1123 \{584 + 0.45 (750 - 40)\}}{10,000} \times 100 = 9.13\%$$

**HEAT LOSS DUE TO OPENINGS**

If a furnace body has an opening on it, the heat in the furnace escapes to the outside as radiant heat. Heat loss due to openings can be calculated by computing black body radiation at the furnace temperature, and multiplying these values with the emissivity (usually 0.8 for furnace brickwork), and the factor of radiation through openings. Graphs can be consulted to determine the factor of radiation through openings.

**Example 3 (cont'd): Solution**

The reheating furnace in the example has a 460 millimetre thick wall (X) on the billet extraction outlet side, which is 1 metre high and 1 metre wide. With a furnace temperature of 1,340°C, the quantity (Q) of radiation heat loss from the opening is calculated as follows:

Shape of the opening is square and D/X	1 / 0.46 = 2.17
Factor of radiation (see Figure 2.4)	0.71
Black body radiation corresponding to 1,340°C	36.00 kCal/cm <sup>2</sup> /h
Area of opening	100 cm x 100 cm = 10,000 cm <sup>2</sup>
Emissivity	0.8
Total heat loss	Black body radiation x area of opening x factor of radiation x emissivity
	36 x 10,000 x 0.71 x 0.8
	204,480 kCal/h
Equivalent oil loss	204,480/10,000
	20.45 kg/h

$$\% \text{ Heat loss} = \frac{20.45 / 368 \times 100}{10,000} = 5.56\%$$

**HEAT LOSS THROUGH SKIN****Method 1: Radiation heat loss from the furnace surface**

The quantity of heat loss from the surface of the furnace body is the sum of natural convection and thermal radiation. This quantity can be calculated using surface temperatures taken

on the furnace. Temperatures on the furnace surface should be measured at as many points as possible, and their average should be used. Too few measurements will result in a large margin of error. The quantity (Q) of heat loss from a reheating furnace is **calculated using the following formula:**

**Example 3 (cont'd): Solution**

$$Q = a \times (t_1 - t_2)^{5/4} + 4.88E \times \left( \left( \frac{t_1+273}{100} \right)^4 - \left( \frac{t_2+273}{100} \right)^4 \right)$$

- Where, Q = Quantity of heat release in kCal/W/m<sup>2</sup>
- a = Factor regarding direction of the surface of natural convection  
ceiling = 2.8 side walls = 2.2 hearth = 1.5
- t<sub>1</sub> = Temperature of external wall surface of the furnace (°C)
- t<sub>2</sub> = Temperature of air around the furnace (°C)
- E = Emissivity of external wall surface of the furnace

The first term of the formula above represents the quantity of heat loss by natural convection, and the second term represents the quantity of heat loss by radiation.

**Method 2: Radiation heat loss from furnace surface**

The following Figure 3.9 shows the relation between the temperature of the external wall surface and the quantity of heat loss **calculated with this graph**

Based on the above graph, it is possible to determine the heat loss quantities per unit area for the ceiling, sidewalls and hearth.

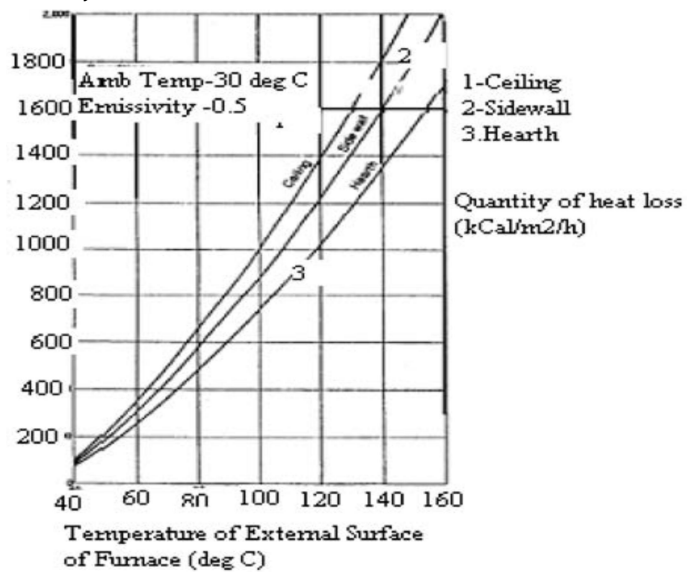

Figure 3.9: Quantity of heat loss at various temperatures

**HEAT LOSS THROUGH ROOF AND SIDEWALLS**

**Example 3 (cont'd): Solution**

Total average surface temperature	122°C
Heat loss at 122°C	1,252 kCal/m <sup>2</sup> /h
Total area of heating + soaking zones	70.18 m <sup>2</sup>
Heat loss	1,252 kCal/m <sup>2</sup> /h x 70.18 m <sup>2</sup>
	87865 kCal/h
Equivalent oil loss (a)	8.78 kg/h



**Example 3 (cont'd): Solution**

Total average surface temperature of area other than heating and soaking zone	85°C
Heat loss at 85°C	740 kCal/m <sup>2</sup> /h
Total area	12.6 m <sup>2</sup>
Heat loss	740 kCal/m <sup>2</sup> /h × 12.6 m <sup>2</sup> 9,324 kCal/h
Equivalent oil loss (b)	0.93 kg/h
Total loss of fuel oil	9.71 / 368
Total loss in percent	2.64%

**UNACCOUNTED LOSSES**

These losses comprise of heat storage loss, loss of furnace gases around the charging door and opening, heat loss by incomplete combustion, heat loss by conduction through the hearth, and loss due to the formation of scales.

**FURNACE EFFICIENCY (DIRECT METHOD)**
**Example 3 (cont'd): Solution**

Fuel input	400 litres/h 368 kg/h
Heat input	368 × 10,000 = 3,680,000 kCal
Heat output	$m \times C_p \times \Delta T$ 6,000 kg × 0.12 × (1340 – 40) 936,000 kCal
Efficiency	936,000 × 100 / (368 × 10,000) 25.43% 25% (approx.)
Total losses	75% (approx.)

**FURNACE EFFICIENCY (INDIRECT METHOD)**
**Example 3 (cont'd): Solution**

Sensible heat loss in flue gas	57.29%
Loss due to evaporation of moisture in fuel	1.36%
Loss due to evaporation of water formed from H <sub>2</sub> in fuel	9.13%
Heat loss due to openings	5.56%
Heat loss through skin	2.64%
Total losses	75.98%
Furnace efficiency	100 – 75.98 = 24.02%
Specific energy consumption	<b>400 litres/hour</b> (fuel consumption) 6 tonnes/hour (W <sub>t</sub> of stock) 66.6 litres of fuel per tonne of material (stock)

» **Factors affecting furnace performance**

Important factors relevant to efficiency are listed below for critical analysis:

- Under-loading due to poor hearth loading and improper production scheduling
- Improper design
- Use of an inefficient burner
- Insufficient draft/chimney
- Absence of waste heat recovery
- Absence of instruments/controls
- Improper operation/maintenance
- High stack loss
- Improper insulation/refractories
- Stop and go operation due to problems with the steel mill. Fuel oil consumption may result in a high SEC if the furnace goes into a forced holding pattern to maintain the furnace temperature due to a site-related constraint or unplanned downtime at the steel mill.

**USEFUL DATA**» **Radiation heat transfer**

Heat transfer by radiation is proportional to the absolute temperature to the power 4. Consequently, radiation losses increase considerably as the temperature increases.

Table 3.3: Heat transfer by radiation

$^{\circ}\text{C1}$	$^{\circ}\text{C2}$ (Ambient temp.)	$K1$ ( $^{\circ}\text{C1} + 273$ )	$K2$ ( $^{\circ}\text{C2} + 273$ )	$(K1/K2)$	Relative radiation
700	20	973	293	122	1.0
900	20	1,173	293	255	2.1
1,100	20	1,373	293	482	3.96
1,300	20	1,573	293	830	6.83
1,500	20	1,773	293	1,340	11.02
1,700	20	1,973	293	2,056	16.91

In practical terms, this means the radiation losses from an open furnace door at 1,500°C are 11 times greater than the same furnace at 700°C. A good incentive for the iron and steel melters is to keep the furnace lid closed at all times and to maintain a continuous feed of cold charge onto the molten bath.

» **Furnace utilisation factor**

Utilisation has a critical effect on furnace efficiency and is a factor that is often ignored or underestimated. If the furnace is at operating temperature, standby losses will occur whether or not a product is in the furnace.

» **Standby losses**

Heat energy is lost from the charge or its enclosure through (a) conduction, (b) convection, and/or (c) radiation

» **Furnace draft control**

Furnace draft control has a major effect on fuel-fired furnace efficiency. Running a furnace at a slightly positive pressure reduces air ingress and can increase the efficiency.

» **Theoretical heat**

**Example 4: Theoretical heat and efficiency calculation**

Example: Melting one tonne of steel starting from an ambient temperature of 20°C. Specific heat of steel = 0.186 Wh/kg/°C, latent heat for melting of steel = 40 Wh/kg/°C. Melting point of steel = 1,600°C.

Theoretical total heat	Sensible heat + latent heat
Sensible heat	1,000 kg x 0.186 Wh/kg/°C x (1600 – 20)°C = 294 kWh/T
Latent heat	40 Wh/kg x 1,000 kg = 40 kWh/T
Total heat	294 + 40 = 334 kWh/T

So the theoretical energy needed to melt one tonne of steel from 20°C is 334 kWh.

The actual energy used to melt the steel to 1,600°C is 700 kWh.

$$\text{Efficiency} = \frac{334 \text{ kWh}}{700 \text{ kWh}} \times 100 = 48\%$$

### 3.5. RECUPERATION OF HEAT

#### WASTE ENERGY STREAMS AND POTENTIAL USES

The following Figure 3.10 shows a simple energy flow diagram of a plant with a number of energy outflows identified. These energy flows are termed waste energy flows, since they are no longer required by the process discharging them. But they may be useful to another process or energy-consuming system. Matching waste energy streams to potential uses involves answering some key questions.

What waste heat sources are available?

- What quantity of heat (energy) is available?
- At what temperature is the heat available?

Where can the heat be used?

- How much energy is required and at what temperature?
- What is the time interval between waste and use?
- At what location is the heat required?

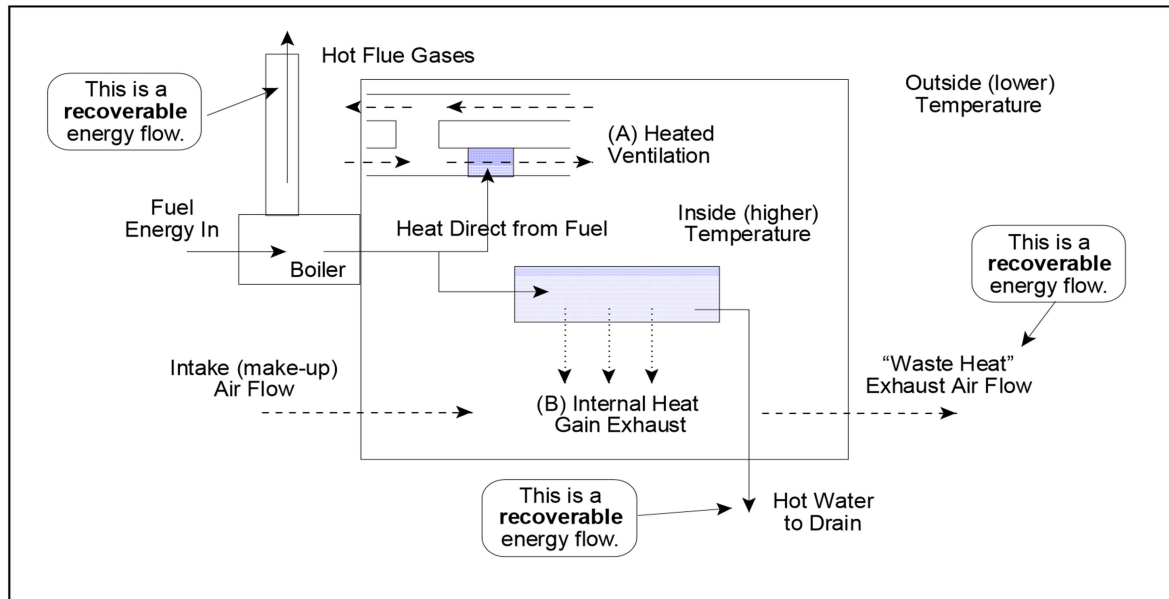

Figure 3.10: Simple industrial waste heat recuperation examples

» *Practical recuperation rate*

**What is the practical recuperation rate? What portion of the waste heat may be used?**

The existence of a “waste” energy stream from one process may provide an opportunity to use the leftover lower-temperature energy in another process. As dictated by basic thermodynamic principles, heat can only flow spontaneously from hot bodies to cold bodies, and any attempt to raise the temperature of a process must involve the use of a hotter “source”. This source is only useful (to that process) so long as its temperature is higher than the “sink” that it is supplying. Should this balance tip, then the heat supply ceases to become useful for the process, and it is this heat that is often discarded.

If, however, that heat supply is hotter than the temperature needed for some other task (e.g. cooling water at 40°C is hotter than is required for space heating) then it should no longer be considered “waste” energy, but instead thought of as a useful energy supply and a means to save money.

» *Direct/indirect heat recovery methods*

Heat recovery involves moving heat energy from one system to another, and the piece of equipment that enables this transfer in most situations is the heat exchanger. In determining the capabilities of the heat exchanger (and hence the viability of performing the transfer), one needs to know the availability of both the heat source and the heat sink in terms of their flows, specific heat capacities, and inlet temperatures. By balancing the energies within the two streams as in the Figure above, it is possible to determine the size and capabilities of the required exchanger. The following two Tables summarise typical exchangers available with a list of typical applications.

Heat recovery methods fall into one of two categories:

- Indirect heat recovery
- Direct heat recovery

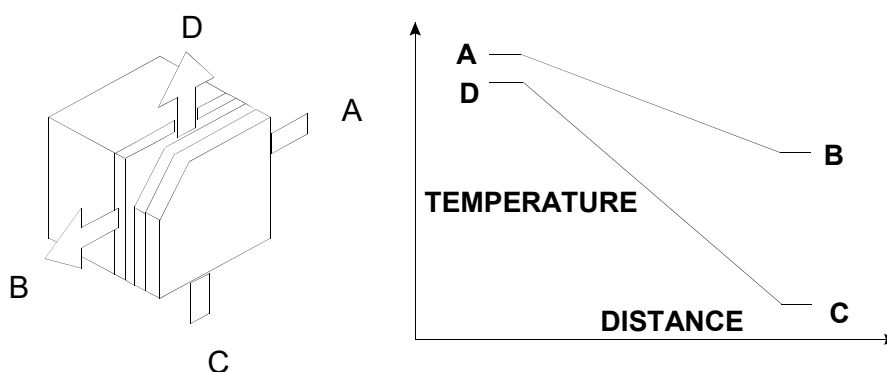

Figure 3.11: Simple heat exchanger temperature profiles

Table 3.4: Direct heat recovery methods

Type	Regime	Exchanger	Typical use
Direct heat recovery	Gas – gas	Cross flow	Commercial air exchange
		Rotary	Flue gas heat recovery
		Regenerative	High temp./low volume exhaust
	Liquid – liquid	Shell & tube	Process water, oil coolers
		Spiral	High-pressure cooling
		Plate & frame	Dairy, process water
		Heliflow	Oil coolers
	Gas – liquid	Recovery boiler	Furnace, engine exhaust
		Evaporative	Water cooling, humidification, exhaust gas Scrubber
Air cooling		Oil cooler, space heating	

Direct heat recovery refers to the transfer of energy from one process stream to another without the addition of work or energy from an outside source. The energy must degrade since heat will only flow from a hot “source” to a cold “sink,” but depending upon the design of the heat sink, the difference between these two temperatures may be just few degrees.

Table 3.5: Indirect heat recovery methods

Type	Regime	Exchanger	Typical use
Indirect heat recovery	Thermal – thermal	Heat pump	Space heating, hot water production
		Absorption chiller	Water chilling, space heating
		Flash tank	Boiler blowdown
		Mechanical vapour recompression	Brewing, sugar processing
		Combustion of waste gases	Sewage treatment, foundries
	Thermal – mechanical/electrical	Expansion turbine	Chemical plants
	Rankine cycle	High-temperature waste gas	

Indirect heat recovery describes the transfer and conversion of energy from one format to another, possibly through the addition of outside energy. It is usually considered a second-

any choice to direct heat recovery because it results in either a lower level of energy recovery or the use of additional, high-grade energy (e.g. electricity, fuel).

### 3.6. HEAT EXCHANGERS

Heat exchangers are devices that transfer heat from one medium to another. Proper design, operation and maintenance of heat exchangers will make the process energy efficient and minimise energy losses. Heat exchanger performance can deteriorate with time, as well as off-design operation and other interferences such as fouling, scaling, etc. Periodic assessment of a heat exchanger's performance is necessary in order to maintain a high level of efficiency. This section comprises certain proven techniques of monitoring the performance of heat exchangers, coolers and condensers based on observed equipment operating data.

#### DESIGN, OPERATION AND MAINTENANCE

##### » Overall heat transfer coefficient (*u*)

Heat exchanger performance is normally evaluated by the overall heat transfer coefficient *U* that is defined by the equation:

$$Q = U \times A \times \text{LMTD}$$

Where, <i>Q</i>	=	Heat transferred in kCal/h
<i>A</i>	=	Heat transfer surface area in m <sup>2</sup> E
LMTD	=	Log mean temperature difference in °C
<i>U</i>	=	Overall heat transfer coefficient kCal/h/m <sup>2</sup> /°C

When the hot and cold stream flows and inlet temperatures are constant, the heat transfer coefficient may be evaluated using the above formula. It may be observed that the cold fluid accumulates less heat with time.

A typical heat exchanger is shown in the Figure3.11. The driving force for any heat transfer process is the temperature difference between two fluids. In the heat transfer process, the two fluids keep changing their temperature as they pass through the heat exchange, meaning that an average temperature is required. The average temperature difference throughout the heat exchange is described by the log mean temperature difference (LMTD). The larger the temperature difference, the smaller the required heat exchange area and vice versa.

Calculation of LMTD: refer Figure 3.12

$$\text{LMTD Counter current Flow} = \frac{(T_i - t_o) - (T_o - t_i)}{\ln \left( \frac{T_i - t_o}{T_o - t_i} \right)}$$

$$\text{LMTD Co current Flow} = \frac{(T_i - t_i) - (T_o - t_o)}{\ln \left( \frac{T_i - t_i}{T_o - t_o} \right)}$$

Where, <i>T</i>	=	Hot fluid
<i>t</i>	=	Cold fluid



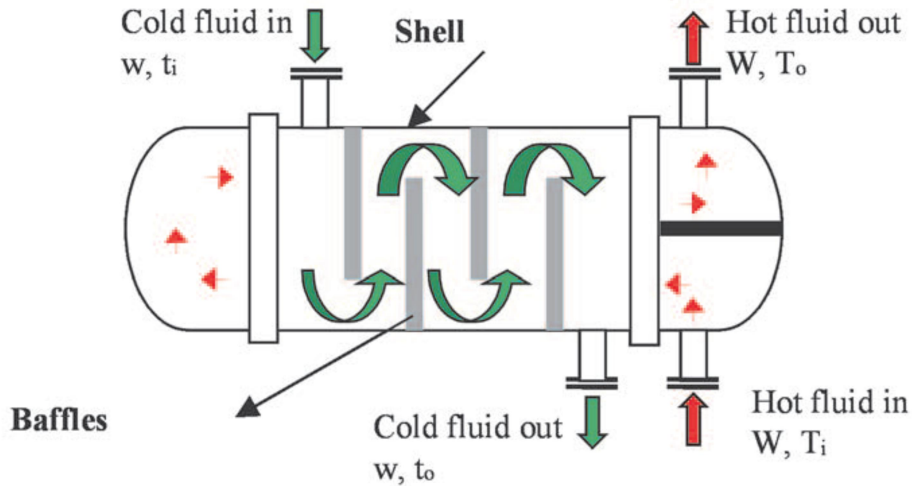

Figure 4.1 Typical Shell and Tube Heat Exchanger

Figure 3.12: Typical shell and tube heat exchanger

The heat duty of the exchanger can be calculated either from the high-temperature fluid side or the low-temperature fluid side, as given below:

Heat duty for hot fluid,  $Q_h = W \times C_{ph} \times (T_i - T_o)$

Heat duty for cold fluid,  $Q_c = W \times C_{pc} \times (T_o - T_i)$

If the operating heat duty is less than the design heat duty, the difference may be due to heat loss, fouling in tubes, reduced flow rate (hot or cold), etc. Hence, for a simple performance monitoring of the exchanger, efficiency may be considered as a performance factor irrespective of other parameters. However, in industrial practice, the fouling factor method is more predominantly used.

**Example 5:** A counter-flow double-pipe heat exchanger operating with hot process liquid is used to heat water flowing at  $10.5 \text{ m}^3/\text{h}$ . The process liquid enters the heat exchanger at  $180^\circ\text{C}$  and leaves at  $130^\circ\text{C}$ . The inlet and exit temperatures of the water are  $30^\circ\text{C}$  and  $90^\circ\text{C}$ , respectively. Water has a specific heat of  $4.18 \text{ kJ/kg}^\circ\text{C}$ .

- a) Calculate the heat transfer area, if the overall heat transfer coefficient is  $814 \text{ W/m}^2^\circ\text{C}$ .  
 What would be the percentile increase in area if the fluid flows were parallel?

Water flow rate	= $10.5 \times 1,000 = 10,500 \text{ kg/h}$
Heat content in water	= $m \times C_p \times T$
	= $10,500 \times 4.18 \times (90 - 30)$
	= $2,633,400 \text{ kJ/h}$
	= $2,633,400 / 3,600$
	= <b>731.5 kW</b>

**For counter-current flow:**

$T_1 = 180 - 90 = 90^\circ\text{C}$     $T_2 = 130 - 30 = 100^\circ\text{C}$

LMTD of counter flow =  $(100 - 90) / \ln(100 / 90) = 95^\circ\text{C}$

Overall heat transfer coefficient =  $814 \text{ W/m}^2^\circ\text{C}$

Heat exchanger area for counter flow =  $731.5 \times 1,000 / (814 \times 95) = 9.5 \text{ m}^2$

**For parallel flow:**

$$T_1 = 180 - 30 = 150^\circ\text{C} \quad T_2 = 130 - 90 = 40^\circ\text{C}$$

$$\text{LMTD of parallel flow} = (150 - 40) / \ln(150 / 40) = 83^\circ\text{C}$$

$$\text{Overall heat transfer coefficient} = 814 \text{ W/m}^2/^\circ\text{C}$$

$$\text{Heat exchanger area for parallel flow} = 731.5 \times 1,000 / (814 \times 83)$$

$$= 10.8 \text{ m}^2$$

$$\begin{aligned} \text{Increase in parallel flow area} &= [(10.8 - 9.5) / 9.5] \times 100 \\ &= 14 \% \end{aligned}$$

**Example 6:** A heat exchanger is to be designed to condense the hydrocarbon vapour mixture from a distillation column at a rate of 11.0 kg/s. The mixture is available at its saturation temperature of 120 C. The latent heat of condensation of the hydrocarbon vapour mixture is 450 kJ/kg. The cooling water at 32 C is introduced in the counter-current direction at a rate of 58 kg/sec to condense the vapour mixture. The specific heat of cooling water is 4.18 kJ/kg/°C. Determine the LMTD and area of the heat exchanger surface if the overall heat transfer coefficient is 550 J/m<sup>2</sup>s°C.

Heat loss in hydrocarbon vapour mixture = heat gain in cooling water

$$\begin{aligned} 11 * 450 &= 58 * 4.18 * (T - 32) \quad T \\ &= 52.4^\circ\text{C} \end{aligned}$$

Water leaves the exchanger at 52.4°C

$$\text{LMTD} = (120 - 32) - (120 - 52.4) / \ln(120 - 32) / (120 - 52.4)$$

$$\text{LMTD of counter-flow pattern} = 77.4^\circ\text{C}$$

$$Q = m * C_p * T = U * A * \text{LMTD}$$

$$\begin{aligned} 58 * 4.18 * (52.4 - 32) * 1,000 &= 550 * A * 77.4 \quad A \\ &= 116.3 \text{ m}^2 \end{aligned}$$

$$\text{Heat exchanger surface area} = 116.3 \text{ m}^2$$

For more examples, e.g. liquid–liquid exchanger; surface condenser; vaporiser; air heater, see: [www.beeindia.gov.in/sites/default/files/4Ch4.pdf](http://www.beeindia.gov.in/sites/default/files/4Ch4.pdf)

 » **Heat exchanger terminology**

**Table 3.6: Heat exchanger terminologies, definitions and units**

Terminology	Definition	Units
Capacity ratio	Ratio of the product of the mass flow rate and the specific heat capacity of the cold fluid to that of the hot fluid. Also given as the ratio of the temperature range of the hot fluid to that of the cold fluid. The higher the ratio the larger the exchanger size.	N/A
Co-current flow exchanger	Exchanger in which the flow direction of the cold and hot fluids are the same.	N/A
Counter-flow exchanger	Exchanger in which the cold and hot fluids flow in opposite directions. Normally the preferred exchanger type.	N/A
Cross flow	Exchanger in which the flow direction of cold and hot fluids intersect.	N/A
Density	Mass per unit volume of a material	kg/m <sup>3</sup>

<b>Terminology</b>	<b>Definition</b>	<b>Units</b>
Effectiveness	Ratio of the cold fluid temperature range to the inlet temperature difference (hot and cold fluid). The higher the ratio the smaller the surface requirement for heat transfer.	N/A
Fouling	Formation and development of scales and deposits over the heat transfer surface which diminishes the heat flux. Fouling process is indicated by an increased pressure drop.	N/A
Fouling factor	The reciprocal of the heat transfer coefficient of the dirt formed during the heat exchange process. The higher the factor, the lower the overall heat transfer coefficient.	(m <sup>2</sup> K)/W
Heat duty	Capacity of heat exchanger equipment expressed in terms of a heat transfer rate, namely magnitude of energy or heat transferred per unit time. Indicates that the exchanger is capable of performing at this capacity in the given system.	W
Heat exchanger	Equipment designed and constructed to transmit the heat content (enthalpy or energy) of a comparatively high temperature fluid to a low-temperature fluid, wherein the temperature of the hot fluid decreases (or remains constant due to latent heat loss caused by condensation) and the temperature of the cold fluid increases (or remains constant due to a latent heat gain caused by vaporisation). Heat exchangers normally provide indirect contact heating, e.g. a cooling tower cannot be called a heat exchanger when water is cooled through direct contact with air.	N/A
Heat flux	Rate of heat transfer per unit surface of a heat exchanger	W/m <sup>2</sup>
Heat transfer	Process of transporting heat energy from a hot source to comparatively cold surroundings	N/A
Heat transfer surface or heat transfer area	Surface area of the heat exchanger that provides indirect contact between the hot and cold fluid in effecting the heat transfer. Heat transfer area is thus defined as a surface wetted on both sides with hot fluid on one side and cold fluid on the other, to provide indirect contact for the heat transfer.	m <sup>2</sup>
Individual heat transfer coefficient	Heat flux per unit temperature difference across the boundary layer of the hot/cold fluid film which forms a coefficient at the heat transfer surface. The magnitude of the heat transfer coefficient indicates the heat conductivity of a given fluid. Becomes greater with an increase in density, velocity, specific heat, or the geometry of the film forming surface.	W/(m <sup>2</sup> K)
LMTD correction factor	Calculated based on the capacity and effectiveness of a heat exchange process. Multiplying the LMTD with this factor yields the corrected LMTD, thus accounting for the temperature differential driving the specific cross-flow pattern inside the exchanger".	N/A
Logarithmic mean temperature difference (LMTD)	Logarithmic average of the terminal temperature approaches across a heat exchanger (see also "Temperature approach" below).	°C
Overall heat transfer coefficient	Ratio of heat flux per unit difference in approach across a heat exchanger considering the individual coefficient and surface conductivity of the metal. Magnitude indicates the heat transfer capacity of a given surface. The higher the coefficient, the lower the heat transfer surface requirement.	W/(m <sup>2</sup> K)
Pressure drop	Pressure difference between the heat exchanger inlet and outlet	Bar
Specific heat capacity	Heat content per unit weight (of any material) per temperature increase or decrease (in Kelvin)	J/(kg/K)
Temperature approach	Temperature difference between the hot and cold fluids at the heat exchanger inlet or outlet. The greater the difference, the greater the heat transfer flux.	°C

<b>Terminology</b>	<b>Definition</b>	<b>Units</b>
Temperature range	Temperature difference between the heat exchanger inlet and outlet for a hot/cold fluid	°C
Terminal temperature	Temperatures at the inlet/outlet of the hot/cold fluid streams across a heat exchanger	°C
Thermal conductivity	Rate of heat transfer by conduction through any substance across a distance per unit temperature difference	W/(m <sup>2</sup> /K)
Viscosity	Force per unit volume on any material caused by pressure	Pa

**Note:** Recommended measures for saving energy in thermal applications must be serviceable by the on-site technical team of the client. They must be financially viable to ensure cost savings can be achieved reducing expenditure of the client.

## 4. ENERGY EFFICIENCY IN INDUSTRIES: ELECTRICAL APPLICATIONS

### *About this module*

This module explores electrical applications commonly used in industrial settings. Equipment such as lighting systems, electric motors, compressed air systems, VAC and power generating equipment are discussed.

### *Learning outcomes*

At the end of this module, the participant is able to

- Describe operational principles of common industrial electrical applications
- Use the corresponding tools and instruments
- Calculate energy losses
- Understand the implications of the fuel and load factor in power generating equipment
- Conceive, analyse and recommend energy conservation measures
- Prepare, present and defend proposals
- Implement measures

### 4.1. LIGHTING SYSTEMS

#### **LIGHTS AND LIGHTING**

Lighting comprises 20 to 40% of energy consumption in commercial buildings and about 2 to 5% in industrial plants. Often, significant energy savings can be implemented with a minimal investment of capital and common sense.

The following forms of illumination are generally used:

- Lighting system for single rooms
- Lighting system for several areas with different lighting requirements
- Direct and indirect lighting

The lighting system designed for a single room enables the control of individual lamps or a group of lamps in the room. These systems are normally installed in offices and combine general lighting and task lighting.

Lighting systems designed for a larger area or for a group of rooms can normally be found in conference centres, restaurants, offices or production areas. Normally the whole area is illuminated even though only a small area is occupied. Typically, problems occur due to the inflexible controls for these lighting systems.

Direct lighting is normally used in office buildings and has the advantage that lamps cast 90 to 100% of their output directly onto the working area. Direct lighting occurs in both general and task lighting. Indirect lighting emits only 0 to 10% of its outputs directly onto the working area. A lighting system may use different lighting sources although incandescent and fluorescent lamps are best known. Each lighting source has its advantages and disadvantages and the use of a lamp depends on the specific lighting requirements.

- Traditional bulbs
- Standard fluorescent lamp
- Compact fluorescent lamps

- New generation fluorescent lamps
- LED technology

**Light yield** is the ratio of the luminous flux emitted by a light source to the power used by this source. It is expressed in lumens per watt (lm/W).

**Ballasts** are required to control the electrical properties of fluorescent lamps. Ballasts are important as they influence the energy consumption of the lamp and guarantee proper operation. There are two types of ballasts:

- Conventional ballasts
- Electronic ballasts

**Conventional ballasts** are used in standard fluorescent lamps. These lamps generally do not guarantee a flicker-free operation and are not as efficient as those with modern electronic ballasts.

**Electronic ballasts** are used in modern fluorescent lamps. These lamps are more expensive than those with conventional ballasts but guarantee flicker-free operation and better efficiency. In addition, their useful life is about 50% longer than lamps with conventional ballasts. Compact fluorescent lamps with integrated ballasts require minimal maintenance. Integrated electronic ballasts are permanently connected to the lamp. Fluorescent lamps with electronic ballasts are often referred to as high-frequency switching lamps.

Illumination requirements depend on the necessary lighting levels for different types of industries, rooms and activities. When evaluating the illumination requirements, it is important to consider the following factors:

- Illumination power measured in luminous flux
- Evenness of the lighting
- Colour rendering

**Luminous flux** is the light quantity which is radiated by a light source per unit of time. Luminous flux is measured with a light meter in lumen.

**Lux** is the metric unit of measure for the illuminance of a surface. One lux is equal to one lumen per square metre. Benchmarks for horizontal illumination power depending on the required accuracy, type of activity, and work space are given in the following table.

**Table 4.1: Illumination depending on required lighting levels**

<i>Degree of work accuracy</i>	<i>Lowest permissible average luminous flux density <math>E_{av}</math> (lumen/m<sup>2</sup>)</i>	<i>Examples</i>
Limited visual needs	50	Staircase, corridors, hall – with little usage
Limited visual needs	100	Staircase, corridors, hall – with heavy usage
Work requiring average accuracy	300	Occasional office work
Accurate work	500	Intense office work, computer laboratory, precise machining
Very accurate work	750	Very precise machining

Colour rendering describes the comfort level of a lamp and has a significant impact on workplace comfort. The vertical illumination power is responsible for the colour rendering.

The horizontal illumination power is responsible for the lighting intensity. As a rule of thumb, the vertical illumination power should reach at least one-third of the horizontal illumination power. Both measurements can be taken directly with a light meter. Lamps with very good colour rendering will normally be used in areas intended to provide a good comfort level or where very precise work is undertaken.

» **Lighting costs**

It is normally not possible to pinpoint lighting costs in an energy invoice, or to undertake separate measurements. Therefore, you will need to perform some calculations to identify your electricity costs. The following step-by-step process provides guidance in this area. Start to evaluate your system by analysing an individual room and then continue with the rest of the organisation.

First, go through the room and identify all lamps in use. Count the number of lamps and multiply each lamp by its power rating in watts. Do not forget to add ballasts for fluorescent lamps. Where ballasts are not known you should generally add in 12% of the power rating for each lamp. This calculation yields a total power rating for the lighting system. Take care to always calculate with the same unit, i.e. kW (1,000 W = 1 kW).

**Example 1:** 71 conventional lamps at 150 W = 10,650 W / 1,000 = 10.65 kW. Calculate the annual number of hours the lighting system is in use by taking the number of office hours per day and multiplying it with the number of business days per year. For a shop open 8 hours per day and 50 weeks in the year, the total annual usage is then 2,000 h.

Multiplying the annual operating hours with the total power rating leads to the annual electricity consumption. Now you can use the unit price from the invoice to calculate your current lighting costs.

**Solution**

$$2,000 \text{ h} \times 10.65 \text{ kW} = 21,300 \text{ kWh}$$

$$\text{Electricity price} = 30 \text{ N} / \text{kWh}$$

$$\text{Total cost} = 639,000 \text{ N/year}$$

**GUIDELINES FOR COST ANALYSIS**

- First, focus on activities which do not require investments.
- Second, focus on activities that increase the efficiency of the current system.
- Third, focus on activities connected with changes to the system itself or building alteration work.

Energy costs for lighting depend on the power requirements of the system and the operating hours. The main focus must therefore be to reduce both the power requirements and operating hours. The following actions and techniques can help:

- Make use of natural light
- Switch off lights
- Perform regular maintenance and cleaning
- Utilise interiors and colours
- Reduce lighting levels, but not below normative lux levels
- Select high-efficiency components



- Use control systems

» **Energy efficiency**

Employees sometimes forget that artificial light is only necessary when there is too little natural daylight. Therefore, it is crucial to raise awareness of electricity use and to encourage staff to switch off lights when daylight is sufficient. In addition, you can maximise the use of daylight through interior design measures such as moving desks next to windows and opening blinds.

**Manual switching off:** Switch off lamps whenever they are not needed. Install more switches so that lighting can be zoned. Opportunities to switch off lights include breaks, lunchtimes and when finishing work. This method is the cheapest because no investment is needed but requires staff awareness.

**Time switch:** For rooms requiring only intermittent or short-term illumination, time controllers are helpful to reduce energy consumption. Automatic lighting control allows lights to be turned off automatically at predetermined intervals.

**Daylight control** allows lights to be switched on and off gradually. Lighting requirements should be continuously adapted, first and foremost, to the needs of staff. Lights do not need to operate 24 hours a day in most cases, although this is sometimes perceived as customer-friendly for businesses such as clothes shops and hotels.

Lighting has become much more energy-efficient in recent years; retrofitting and relighting projects can save a considerable amount of energy. Furthermore, additional energy savings can be achieved by using intelligent lighting control systems. The energy efficiency of a lighting system is expressed in:

$$\text{Efficacy of a light bulb} = \frac{\text{Output: lumen (lm)}}{\text{Input: electrical power (W)}}$$

Where lumen is a unit of luminous flux - a measure of the total quantity of visible light emitted by a source. The lumen rating is usually indicated on the bulb package, expressed in terms of “brightness”. Different lighting technologies have very different efficiencies.

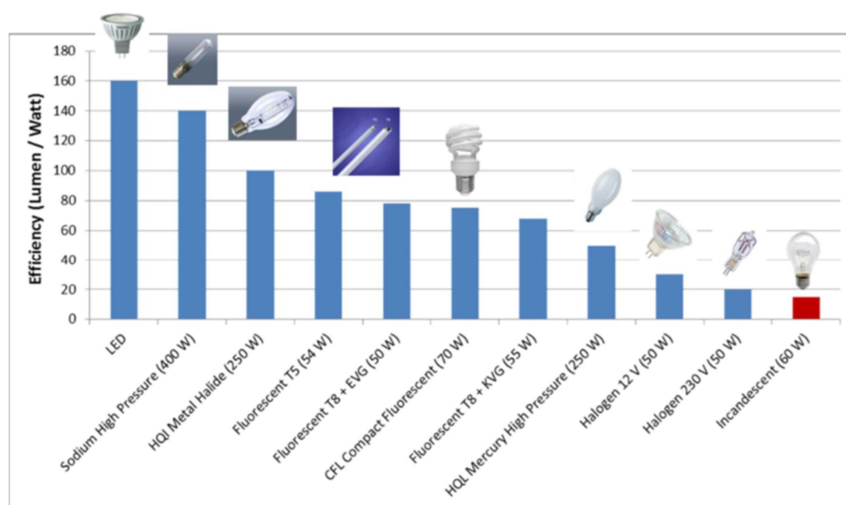

Figure 4.1: Energy efficiency of different lamps

Replacing all lamps with energy-efficient lighting fittings and bulbs is a major undertaking. It is more advisable to make the switch to efficient fixtures during repair and maintenance work and to continuously update the system. This is also true for replacing old thick fluores-

cent lamp models with newer and thinner ones as they have a higher light intensity and offer an energy savings of up to 5%. When fluorescent lamps flicker, their energy consumption is up to 30% higher, and the ballast has to be checked.

Selecting energy-efficient components also includes regular window cleaning, painting walls in bright colours, and cleaning the surfaces, reflectors and coverings of all lamps.

LED technology is state-of-the-art in terms of efficiency and also offers the lowest life cycle cost. For industrial purposes, high-pressure sodium (HPS) and metal halide (MH) lamps are commonly used as efficient systems. However, many industrial plants still use the common high-pressure mercury (HPM) lamps with a very low efficiency.

#### » *Energy efficiency measures in lighting systems*

A lighting upgrade can cut energy bills, improve the appearance of a facility, and boost employee morale, but all these benefits can fade if the new lighting systems are not well maintained. All lighting systems experience a decrease in light output and efficiency over time, because:

- Lamp light output decreases (lamp lumen depreciation)
- Dirt accumulates on fixtures (luminaire dirt depreciation)
- Lamps burn out
- Control systems drift out of spec or are overridden by occupants

To keep your lighting system clean and in good working order, you will need a maintenance plan. For maximum effectiveness, maintenance should be addressed right from the start of the design process through the following measures:

- Design lighting systems with components that minimise light loss over time, are easy to maintain, and use the fewest different types of lamps.
- Train personnel in proper maintenance techniques, including cleaning and re-lamping.
- Control purchasing and inventory to ensure that only the right replacement components are available.

#### **CONTROL SYSTEMS**

Lighting control systems are an effective instrument to reduce energy consumption. Their main disadvantage is that they require high investments and are only economical in buildings where lighting makes up a large portion of the electricity bill. Lighting control systems should therefore be considered in the planning phase of a building. The following control systems are commonly used:

- Motion control
- Daylight control
- Time clock
- Remote control

**Motion control:** Motion detectors switch lights off when there is no occupancy in a building segment. Experience shows that motion detectors reduce energy consumption significantly, but their installation requires high investment costs.

**Daylight control:** Daylight detectors dim lights or switch them off when daylight reaches the detector. Installation may require high investment costs but also yield significant savings.

Users are more likely to accept daylight control systems when artificial lighting is gradually reduced.

**Time clock:** Lights are turned on and off at predetermined intervals. Typical examples are shop window displays.

**Remote control:** Uses a device similar to your TV remote control. Individual users can control the luminous flux in the room according to their needs. An additional advantage of using remote control is that no wiring is required.

## 4.2. ELECTRIC MOTORS

### ELECTRIC MOTORS AND APPLICATIONS

Electric motors offer a great opportunity for improving energy efficiency in industrial settings. Electric motors are the primary mover for a vast majority of industrial activities. They account for approximately 65% of the electricity consumed by industry and many motors are rather old and not yet optimised for energy efficiency. Motors with low energy efficiency will dissipate their losses as heat. This phenomenon increases energy costs. Over the course of time, the heat will also affect the motor condition, reducing its energy efficiency even further and increasing the risk of failure.

Electric motors have three main system boundaries. Moving from the first to the third boundary systematically expands the system, which, in consequence, increases its complexity as well as its potentials for energy efficiency improvements.

Electric motor system boundaries:

1. The electric motor itself
2. The core motor system, which can comprise a variable speed drive, driven equipment (fan, pump or compressor) and the connection (gear or belt)
3. The total motor system, which also includes ducting or piping systems and all possible end-use equipment like compressed air tools. It may also entail an uninterruptible power supply.

In these boundaries, motor systems have different energy losses.

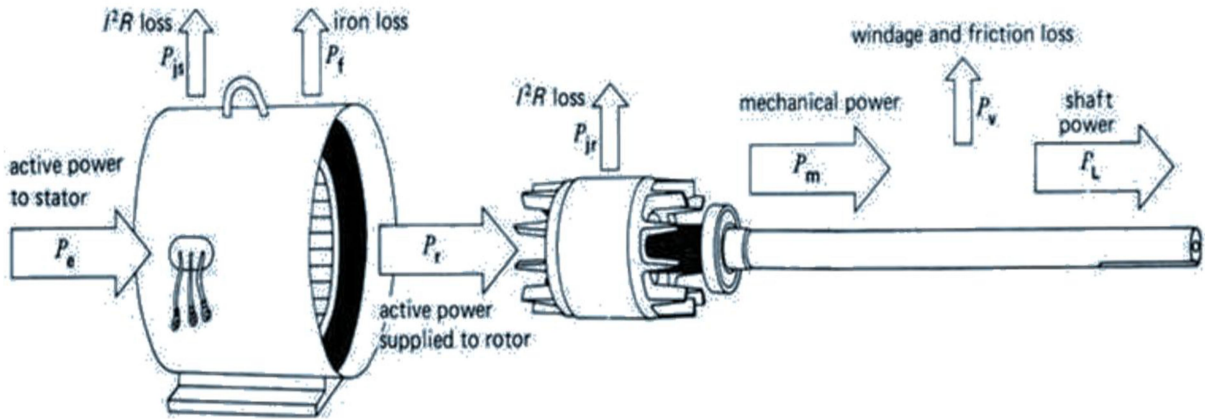

Figure 4.2: Motor energy losses

The main factors that influence motor efficiency are age, capacity, running speed, type of control, temperature in the working environment and load served. Motors are designed for a load of 50 to 100% of their nominal capacity. They run most efficiently at a 75% load and their efficiency rapidly drops below a 50% load.

» **Determining motor load: Input power measurement**

When direct-read power measurements are available, the motor’s part-load can be calculated using three formulas:

1. Calculate the three-phase input power to the loaded motor:

$$P_i = \frac{V \times I \times PF \times \sqrt{3}}{1000}$$

2. Quantify the motor’s part-load:

$$P_r = hp \times \frac{0.7457}{\eta_r}$$

Where,  $P_r$  = Input power at full rated load in kW  
 $hp$  = Name plated rated horse power  
 $\eta_r$  = Efficiency at full rated load

3. The % loading relationship

$$Load = \frac{P_i}{P_r} \times 100\%$$

Where, Load = Output power as a % of rated power  
 $P_i$  = Measured 3-phase power in kW  
 $P_r$  = Input power at full rated load in kW

**LINE CURRENT MEASUREMENT**

Down to about 70% of full load, the amperage draw of a motor varies in a near linear fashion with respect to load as shown in this diagram. Below the 70% load point, due to reactive magnetising current requirements, the power factor degrades and the amperage curve becomes increasingly non-linear. In the low load region, current measurements are not a useful indicator of load.

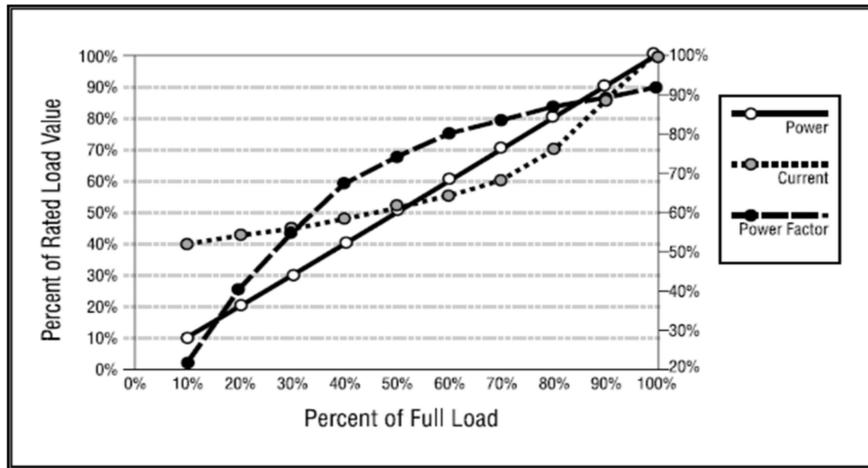

Figure 4.3: Typical induction motor characteristic curves

**Example 2:** Estimate the percentual load of the induction motor with the following data using the input power method, line current method and slip method.

Name plate details: Rated kW of motor (output) = 30 kW,  
 Rated amps = 55 A,  
 Rated voltage = 415 V,  
 Name plate efficiency = 92%  
 Name plate speed = 1,440 rpm,  
 No. of poles = 4,  
 Frequency = 50 Hz

Operating data:

Measured speed = 1,460 rpm, Input load current = 45 A, Operating voltage = 425 V,  
 Input power = 20 kW

**Solution**

a) Input power method: Input power at full rated power in kW,  $P_i = 30 / 0.92 = 32.6$  kW, percentage loading =  $20 / 32.6 = 61.3\%$

b) Line current method: % load = [input load current / input rated current] x [rated voltage / operating voltage] x 100

$$= [45 / 55] \times [415/425] \times 100 = 79.9\%$$

c) Slip method: Synchronous speed =  $120 \times 50 / 4 = 1,500$  rpm, slip =  $1,500 - 1,460 = 40$  rpm

$$\%loading = \frac{40}{(1500 - 1440) \times (415/425)^2} \times 100\% = 69.9\%$$

» **Energy efficiency measures in electric motors**

Electric motors should be replaced proactively, prior to failure. Indeed, a closer look at all cost factors will reveal that an early replacement is often paid back in a very short time. This payback is not only fed by improved energy efficiency, but also by reduced maintenance costs, and by avoiding unplanned outages and associated losses.

Additional measures include the use of a soft starter technology for motors and correct motor sizing to avoid a maximum demand charge and overburdening of the power infrastructure, or partial or inefficient operation of motors. Also reduce under-loading.

Moreover, planners can optimise component selection to include variable speed drives (VSD) in pumps, permanent magnet motors, copper die-cast rotors, superconductivity, screw compressors for refrigeration, etc.

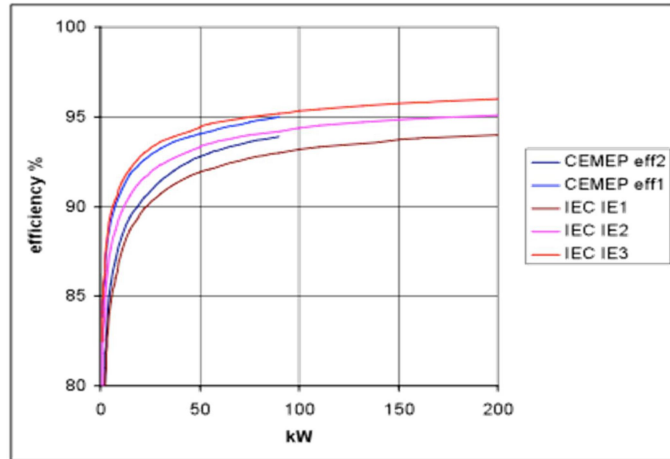

Figure 4.4: IEC motor efficiency classification

To optimise the system, check and replace the throttle if necessary, plug leaks, ensure correct pump impeller sizing, and introduce appropriate behavioural measures for energy conservation.

**MOTOR EFFICIENCY CLASSES**

A classification of motor efficiencies in the range of 0.75 to 375 kW is internationally documented in the IEC classification:

» *Power factor improvement at motor terminals (concept explained with an example)*

**Example 3:** A 3-phase, 415 V, 110 kW induction motor is drawing 50 kW at a 0.75 PF. Calculate the capacitor rating requirements at the motor terminals for improving the PF to 0.95. Also, calculate the reduction in current drawn and kVA reduction, from the point of installation back to the generating side due to the improved PF.

Solution: kVAr rating = kW [Tan  $\phi_1$  – Tan  $\phi_2$ ]

Cos  $\phi_1$  = 0.75,  $\phi_1$  = Cos(inv) 0.75 = 41.41, Tan  $\phi_1$  = 0.882

Cos  $\phi_2$  = 0.95,  $\phi_2$  = Cos(inv) 0.95 = 18.2, Tan  $\phi_2$  = 0.329

Therefore, kVAr rating = 50 kW (0.882 – 0.329) = 27.65 kVAr (consider a lower overall kVAR rating of 25 kVAr and not 30 kVAr, as the motor is not to be overcompensated)

Current drawn at 0.75 PF =  $50 / \sqrt{3} \times 0.415 \times 0.75 = 92.8$  A

Current drawn at 0.95 PF =  $50 / \sqrt{3} \times 0.415 \times 0.95 = 73.3$  A

Reduction in current drawn = 92.8 – 73.3 = 19.5 A

Initial kVA at 0.75 PF =  $50 / 0.75 = 66.7$  kVA

kVA at 0.95 PF =  $50 / 0.95 = 52.6$  kVA

Reduction in kVA = 66.7 – 52.6 = 14.1 kVA

**Note:** The above values are to be readjusted corresponding to 25 kVAr capacitors

» **Variable speed drives (VSD)**

VSDs are also known as inverters. Where process conditions demand an adjustment of the input flow from a pump or fan, varying the speed of the drive may save energy compared with other techniques for flow control.

**Concept of variable frequency drive**

The speed of an induction motor is proportional to the frequency of the AC voltage applied to it, as well as to the number of poles in the motor stator. This is expressed by the equation:

$$\text{RPM} = (f \times 120) / p$$

Where,  $f$  = Frequency in Hz

$p$  = Number of poles in any multiple of 2

Therefore, if the frequency applied to the motor is changed, the motor speed changes in direct proportion to the change in frequency. The VSD controls the frequency which is applied to the motor.

The VSD's basic principle of operation is to convert the electrical system frequency and voltage to the frequency and voltage required to drive a motor at a speed other than its rated speed. The two most basic functions of a VSD are to convert power from one frequency to another, and to control the output frequency.

Drives that enable speed selection from several different pre-set ranges are usually known as adjustable-speed drives. If the output speed can be continually adjusted over a range, the drive is usually referred to as a variable speed drive. Induction motors change their speed by converting 50 Hz of incoming power to a variable frequency and voltage. VSDs can be installed in existing systems and reduce electricity demand by about 10 to 30% in fan and pump motor systems, "depending on the actual flow control and its frequency.

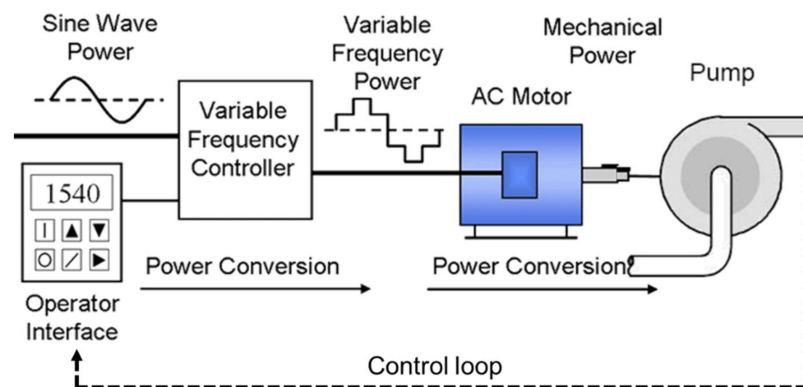

Figure 4.5: Variable motor speed drive

**4.3. COMPRESSED AIR SYSTEMS**

**OPERATION AND COST OF COMPRESSED AIR SYSTEMS**

Compressed air is a major energy consumption factor in many manufacturing operations. Electricity used to compress air is converted into heat and potential energy in the compressed air stream. Efficient operation is achieved by following these guidelines:

- Select the appropriate type and size of the compressor for the duty cycle required.
- Ensure proper operation of compressed air systems, as it can also lead to improved energy utilisation.



- Avoid leaks, since leakage is the greatest efficiency offender in compressed-air systems.
- Substitute electric motors for air motor (pneumatic) drives.

The supply of compressed air accounts for 10 to 15% of the average industrial consumer’s electricity bill. It is used for processes as diverse as paint spraying, bottling, blow moulding, vacuum production and transportation applications.

The demand side of the compressed air system includes the distribution system with regulators, valves, hoses, and fittings. It also employs a storage tank and the end-use equipment. For a typical air compressor, the energy consumption represents 75% of the lifetime cost of operation, and so energy efficiency should be the priority for reducing the total costs of compressed air.

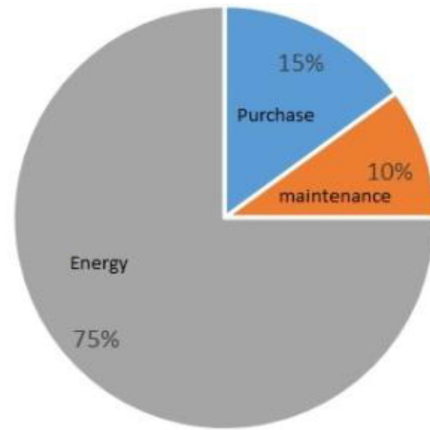

Figure 4.6: Life cycle costs (LCC) of a compressed air system

» **Energy efficiency measures in compressed air systems**

Numerous energy conversions, storage and transportation steps lead to significant energy losses and inefficiencies. Efficiency improvements are available at practically all points in the system.

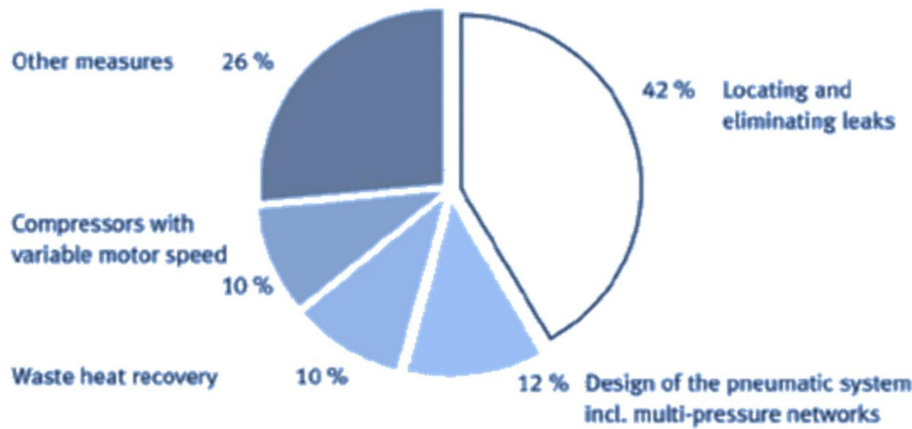

Figure 4.7: Energy saving potential in compressed air systems

» **Cost of compressed air leaks**

The main source of losses in a compressed air system is leaks in fittings, hoses, connections, etc. Leaks can account for up to 30% of compressed air consumption and, thus, electrical consumption. Some typical leakage rates for different hole sizes are given in the table below.

Table 4.2: Air pressure leakage

Hole Diameter (in)	Flow rate (SCFM)	Power Loss (hp)	Demand loss (kW/mo)	Energy loss(kWh/yr)	Leak cost (USD/yr)
1/64	0.33	0.09	0.82	594	35
1/32	1.33	0.36	3.26	2,375	142
1/16	5.33	1.46	13.05	9,498	566
1/8	21.33	5.83	52.19	37,994	2,264

Hole Diameter (in)	Flow rate (SCFM)	Power Loss (hp)	Demand loss (kW/mo)	Energy loss(kWh/yr)	Leak cost (USD/yr)
1/4	85.33	23.32	286.76	151,974	9,055
1/2	341.33	93.28	835.02	607,897	36,222

» **Simplified air leakage test**

- Determine the free air delivery capacity (Q) of your compressor (litres/second).
- Find a time when the equipment is connected to the compressed air system but not in use. Turn on the compressor and allow it to come up to full pressure.
- Record the time (t) until the compressor starts again (loads).
- Record the time (T) until the compressor stops (unloads).
- Repeat the above two measurements at least four times.
- Average the t and T cycles.
- Calculate the leakage

Leakage:

$$Q \times T / (T + t) \text{ litres/s}$$

**COST CALCULATIONS FOR ENERGY SAVINGS AND LEAKAGE**

After determining the leakage rate as explained above, calculate the cost of leaks.

Leakage cost (Naira/year):

$$= \frac{\text{leakage (L/s)} \times \text{actual load (kW) measured}}{Q(\text{L/s}) \times \text{operating time (h/y)} \times \text{energy cost (N/kWh)}}$$

» **Low cost, no cost and higher cost actions**

**LOW COST OR NO COST ACTIONS**

- Identify and fix leaks on a regular basis. This can reduce compressed air use by over 10%.
- Reduce the system pressure to a minimum, based on your requirements. A reduction of 1 bar will save 7%.
- Fit pressure indicators on air filters to show when they require changing (at 0.5 bar(g) or in line with the manufacturer’s specification).
- Partially or completely isolate unused equipment or network legs whenever possible to reduce leakage.
- Replace older unreliable condensate drain traps with modern and more energy-efficient and reliable electronic condensate drain traps.

**HIGHER COST ACTIONS**

- Look at where compressor air is being used. Are there lower cost alternatives?
- Move the air compressor inlet to a cooler location. A reduction of 10°C can save 3.5% in energy consumption.
- Air quality requirements should be carefully specified according to your needs. Excessive air quality increases energy costs. Reduce inefficient frequent cycling by installing an air receiver close to the compressors, and also near applications with a particularly high but periodic demand.

- When purchasing air compressors, ensure that the full load and part-load energy performance is specified and measured in accordance with specific inlet conditions.
- Rotary screw compressors can be supplied with integrated variable speed drives (VSDs) to improve part-load performance.
- Look for heat recovery opportunities in the air compressor installation.
- Maintenance of compressors and dryers is important to ensure optimal efficiency and avoid unplanned outages.

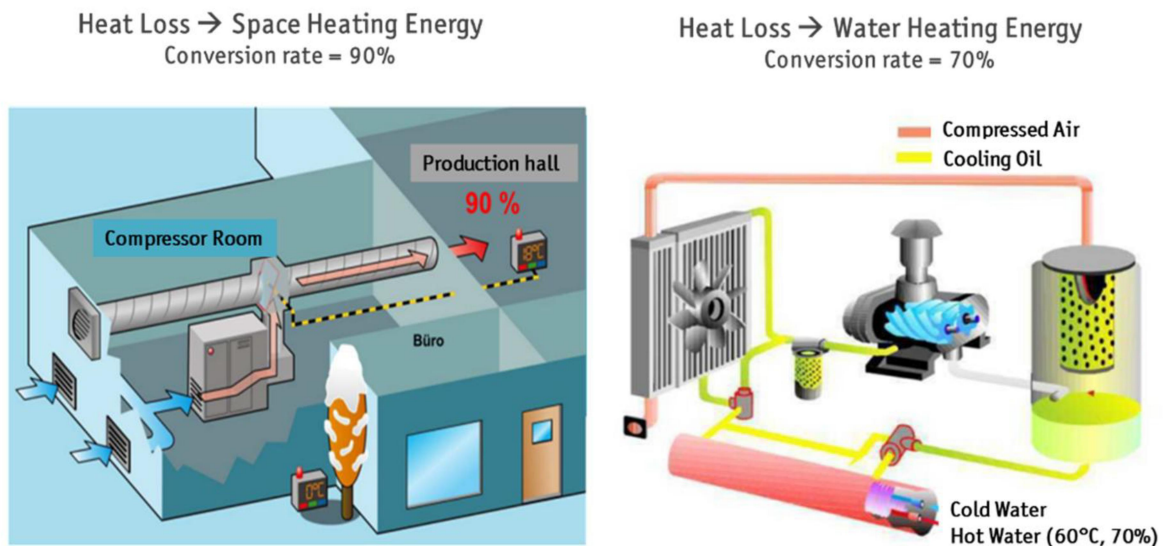

Figure 4.8: Waste heat recovery in compressed air systems

#### 4.4. VENTILATING, AIR CONDITIONING AND REFRIGERATION SYSTEMS

##### EFFICIENT OPERATION OF COOLING SYSTEMS

The environmental needs in an industrial operation can be quite different from those in a residential or commercial structure. In some cases strict environmental standards must be met for a specific function or process. More often the environmental requirements for the process itself are not overly stringent; however, conditioning of the space is necessary for the comfort of operating personnel, and thus large volumes of air must be processed. Efficient operation can be achieved by following these guidelines:

- Review VAC controls. Building cooling controls should be examined and preset.
- Ventilation, air, and building exhaust requirements should be examined. An airflow reduction will also reduce the electrical energy delivered to motor drives.
- Do not condition spaces needlessly. Review air conditioning, seal off sections of plant operations that do not require environmental conditioning, and use air conditioning equipment only when needed. During nonworking hours the environmental control equipment should be shut down or reduced. Automatic timers can be effective.
- Provide proper equipment maintenance. Ensure that all equipment is operating efficiently (filters, fan belts, and bearings should be in good condition).
- Use only the equipment capacity that is actually needed. When multiple units are available, examine the operating efficiency of each unit and put operations sequence

in merit order (preference to operation of efficient units in order to maximise overall efficiency).

- Recirculate conditioned (cooled) air where feasible. If this cannot be done, check whether exhaust air can be used as supply air for certain processes (e.g., a paint spraying) to reduce the volume of air that must be conditioned.
- The first principle of energy conservation is turning off equipment whenever it is not needed.

» **Ventilation systems**

Industrial ventilation generally involves the use of supply and exhaust ventilation to control:

- Emissions
- Exposures and
- Chemical hazards in the workplace

**TYPES OF VENTILATION**

Different systems and methods for ventilation are available depending on the specific requirements. In general there are two types of ventilation: natural ventilation and mechanical ventilation.

**Natural ventilation**

There are many office buildings throughout Europe that rely on natural ventilation to meet all of their cooling needs. In North America, there is a growing trend towards natural ventilation and many new buildings have operable windows. Turbo ventilators are now finding an increased use in industrial sheds. Hot air inside these sheds tends to rise. When the ventilators rotate, they suck the warm air out through the vents, allowing a supply of fresh air at ambient temperature to enter through the doors and windows.



**Figure 4.9: Turbo ventilation system** – Courtesy: Sudha Ventilating Systems

**Mechanical ventilation**

Systems are capable of providing a controlled air exchange and responding to the varying needs of occupants as well as to pollutant loads. In general, incoming supply air is filtered and some systems are equipped to recover heat from the exhaust air stream. Mechanical ventilation is often essential in large office buildings where fresh air must penetrate to the centre of the building and high heat gains can cause overheating.

The necessary ventilation quality depends on the amount and nature of contamination present in a space. Two basic rules of thumb for ventilation rates are provided in the below:

1. Airflow for humans (25.2 m<sup>3</sup>/h per person)
2. Airflow to ventilate emission from construction materials (2.5 m<sup>3</sup>/h per floor area)

- Approximately 30% of the energy delivered to buildings dissipates in departing ventilation and exfiltration air streams.
- In buildings constructed to very high standards of thermal insulation, the proportion of airborne energy loss can be much higher.

» **Components and efficiency**

The most comprehensive and complex ventilation systems consist of the following components:

- |                                       |   |
|---------------------------------------|---|
| ▪ Fans                                | ▪ Heat recovery systems                   |
| ▪ Air-cleaning and filtration systems | ▪ Components for indoor air recirculation |
| ▪ Cooling and humidification systems  | ▪ Control systems                         |

All components are important when discussing energy efficiency. Many of the components are selected during the design phase, but component maintenance and replacement often occur during the operation phase.

**FANS**

Fans are used in ventilating units to transport the air from various air intakes through the duct system to the room which is to be ventilated. Every fan must overcome the resistance created by having to force air through ducts, bends and other ventilation equipment.

This resistance causes a pressure drop whose size is critical when choosing the dimensions of individual fans. Fans can be divided into two basic categories determined by the impeller's shape and operating principle: radial fans and axial fans.

**Radial fan:** Radial fans are used when a very high total pressure is required. The particular characteristics of a radial fan are essentially determined by the shape of the impeller blades.

**Axial fan:** The simplest axial fan is a propeller fan. A freely rotating axial fan of this type has a very poor efficiency rating, so most axial fans are built into a cylindrical housing. Efficiency can also be increased by fitting directional vanes immediately behind the impeller to direct the air more accurately. The efficiency rating can be 75% without directional vanes and up to 85% with directional vanes.

*Efficiency of fans*

Fan connections to the inlet and outlet must be designed in a specific way to avoid losses.

As a rule of thumb it can be said that the

- Duct diameter on the inlet side must have the same size as the inlet
- Duct diameter on the pressure side (outlet) must be 3 times larger than the duct diameter on the inlet side.

Radial fan connections must be at least 5 times larger on the suction side (inlet), and the same size as the duct diameter on the pressure side (outlet). Deviating connection sizes can result in a greater pressure reduction. This extra pressure drop is called the system effect or system dissipation, and can cause the fan to produce a smaller volume of air.

*Specific fan power*

There are now stringent requirements to ensure that power consumption in a building is as efficient as possible so as to minimise energy costs. Specific fan power (SFP) has been intro-

duced as a measurement of a ventilation system's energy efficiency. The SFP for an entire building can be defined as the power consumption of all the fans in the ventilation system divided by the total air flow through the building. The lower the value, the more efficient the system is at transferring the air. For example, in Norway the recommendations for public sector purchasing are that the maximum SFP should be 2.0 when maintaining and repairing ventilating units, and 1.5 for new installations.

To calculate the SFP the following information is required:

- Power of all fans in the system (kW)
- Volume flow of air in the system (m<sup>3</sup>/s)

$$\text{SFP} = P/V \text{ [kW/(m}^3\text{/s)]}$$

To obtain the power of all fans it is necessary to measure the kW input and the volume flow with the appropriate instruments.

#### AIR-CLEANING AND FILTRATION SYSTEMS

There are two reasons for using filters in an air-handling unit:

- To prevent impurities in the outside air from entering the building
- To protect the unit's components from contamination.

#### CONTROL SYSTEMS

Ideally, buildings should have minimal HVAC (heating, ventilation, and air conditioning) systems. However, most modern urban buildings, due to their locations and building constraints, require more extensive electrical and mechanical systems with automatic control equipment.

- The best control strategy allows occupants to directly manipulate simple and understandable building features such as windows or shades.
- Controls should provide immediate feedback on their effects.
- Controls should not require occupant attention to ensure safe, healthy indoor conditions, low energy consumption or operating costs.
- Automatic building controls must ensure that the building operates efficiently regardless of occupant behaviour.

All of the following system components are important when discussing energy efficiency:

**Fans:** While fans can offer an efficiency of 80 to 85%, the inappropriate choice and/or dimensioning of a fan can result in an efficiency of less than 50%!

**Air cleaning and filtration:** Along with ensuring the proper condition of filters, all system components require regular cleaning. Dust covering a heat recovery unit will decrease performance from 80% to 20%.

**Control systems:** The potential energy savings gained from controllers can be up to 60% of ventilation energy costs, depending on the building type and use as well as the local climate.



Table 4.3: Best efficiency parameters

<b>Parameters</b>	<b>Functions</b>
Direct digital control (DDC)	Allows precise, flexible management of the electrical and mechanical parts of a ventilation system. Digital controls can easily respond to building modifications and changing occupancy needs throughout the life of the building.
Occupancy sensors	Ensure that the air flow rate will be reduced or switched off when people are not at their workspace/desk.
Daylight controls	Allow occupants to adjust lighting according to their needs. Reduced electricity use translates into lower cooling loads, smaller HVAC equipment and lower energy consumption.
Fan motor controllers	Ensure that the motor speed is correctly matched to the load requirements of the ventilation system.
Time clocks	Provide very simple and low-cost controllers which often can be quickly installed.

#### 4.5. FANS, BLOWERS, PUMPS AND SYSTEMS

Simple control changes are the first thing to consider with these component and equipment types. Switches, timers, or other devices can be installed to ensure that they only operate when needed by the process. The size of fans and pumps is then dictated by heat removal requirements or process mass flow rates. Variable speed drives (VSDs) are another technique for reducing process energy use. VSDs permit fans, blowers, and pumps to vary their speed depending on process requirements. This can lead to significant savings for non-continuous processes.

Fans, blowers and pumps are the mechanical conversion devices used to satisfy the requirements for fluid movement. In terms of consumption, they can easily account for 50% of all electricity consumed in a plant. Though their individual efficiencies can reach up to 80%, issues such as faulty application, misuse and lack of regular maintenance often mean that extensive savings opportunities have yet to be realised.

##### » *Affinity law*

Fan and pump systems share many similar characteristics and may thus be analysed, from an energy perspective, in similar ways. Each is typically driven by a motor, either directly or through a belt or gearbox. Both systems will frequently utilise centrifugal devices to create motion in the fluid or air and as a result both systems are governed by a set of rules known as affinity laws. The affinity laws describe the relationship between the required speed, flow, pressure and power.

The power required for the movement of air or fluid in the system downstream of the fan or pump is governed by the pressure drop presented by the system to the flow. Both systems share significant losses in friction downstream and consequently share similar opportunities for flow balancing, static and dynamic head (pressure) reduction and speed control rather than throttling for flow control. Identifying energy savings opportunities in fan and pump systems involves critically assessing the existing energy use.



Table 4.4: Relationship between require speed, flow, pressure and power

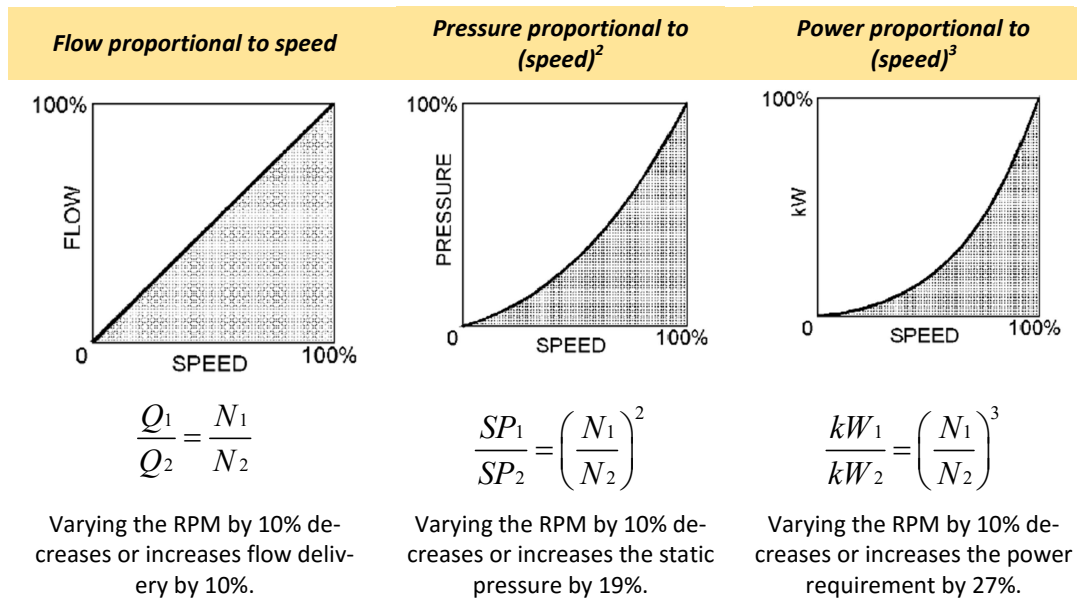

Where Q – flow, SP – static pressure, kW – power and N – speed (RPM)

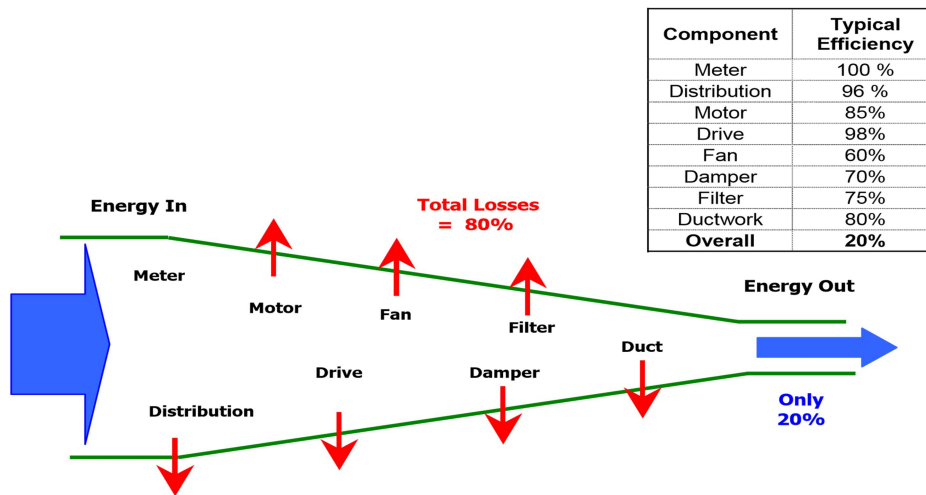

Figure 4.10: Sankey diagram of fan system energy flows

The various losses shown in this Sankey diagram are itemised and defined in Table 4.5.

Table 4.5: Energy flows in a fan (pump) system

Energy flow	Description	Key factors for evaluation of flow	Portable instrumentation used for evaluation
Electrical distribution losses	Heat from resistance of the wires	Voltage drop in wiring	Handheld power meter or clip-on ammeter
Motor losses	Heat created at the motor during conversion from electrical to mechanical power	Motor efficiency rating and operating conditions, namely applied voltage, loading and temperature	Motor efficiency rating, temperature measurement of motor, tachometer to check motor loading speed
Drive losses	Heat created due to friction in the bearings, pulleys and belts.	Belt tension, bearing and belt temperature.	Infrared temperature measurement
Fan (pump) losses	Heat created due to friction and fluid vis-	Fan (pump)	Flow and pressure measurements

Energy flow	Description	Key factors for evaluation of flow	Portable instrumentation used for evaluation
	Losses caused by the fan (pump)	Highest efficiency rating at operating point defined by flow rate and pressure drop as specified by the fan (pump) curve	
Damper (valve) losses	Heat and pressure drop created by friction damper (valve)	Damper (valve) setting and pressure drop inlet to outlet	Differential pressure measurement
Filter (strainer) losses	Heat and pressure drop created by airflow friction in filter (strainer)	Pressure drop across filters (strainers)	Differential pressure measurement
Ductwork (pipework) losses	Heat and pressure drop created by friction between air (or water) flow and ductwork (pipework)	Pressure drop per unit length or overall	Differential pressure measurement
Air (water) power delivered	Quantity of air (water) power delivered at the terminal point such as the diffuser or outlet (end-use heat exchanger)	Pressure difference and flow achieved at the end-use point	Flow and pressure measurement

» **Assessment of fans and pumps**

Fans and pumps work in conjunction with a fluid distribution system. When operated outside the ideal operating range (with pressure or flow rates that exceed or fall below specified norms), their reasonable efficiencies can fall dramatically. Thus, the following approach is suggested:

Determine the flow requirement and match the delivered flow in time and volume. Analyse the fluid distribution systems. Estimate and quantify the pressure drop, since a pump/blower supplier needs this data to advise you on the correct design and capacity of the pump/blower system. Look for ways to reduce resistance to flow. Ensure that the pump or fan is suitable for the application and is operating at near optimal conditions – if not reconsider the pump/fan selection.

Figure 4.11 shows the relationship between pressure, flow and the optimum operating point for a centrifugal pump. The most efficient operation of the pumping system is at the optimum point where the flow restriction reaches its minimum. A similar set of relationships exists for centrifugal fans and blowers.

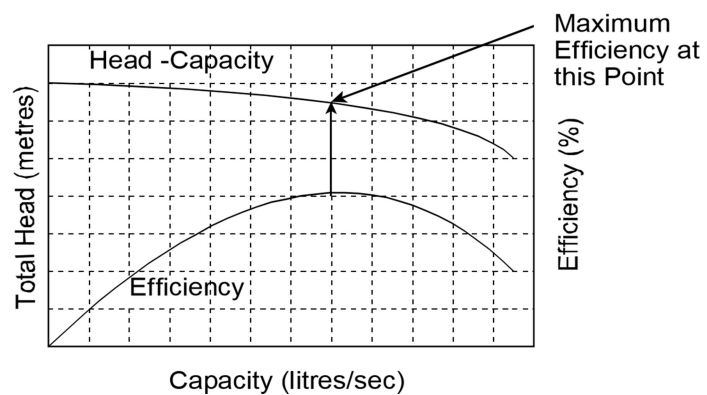

Figure 4.11: Optimum pump operation

» **Selected savings opportunities**

More detailed analysis is required to realise the following opportunities:

**CLEAN AND BALANCED AIR DISTRIBUTION SYSTEMS**

Poorly maintained air distribution systems will increase the power required by the fan to circulate air. Avoid excessive closing of dampers when balancing a system. Consider fan speed and hence flow reductions after balancing a system in order to minimise the use of dampers for flow control.

**CHECK OVERALL FAN/PUMP SIZING AND EFFICIENCY**

Subsequent changes to the initial design of a system can result in inefficient fan/pump operation. This occurs when the conditions imposed upon the fan/pump are not ideal for the type and/or size of the fan/pump. By re-considering the design and operating conditions of the fan/pump, it may be possible to make changes that will result in higher efficiency.

**ELIMINATE AIR FLOW REDUCTION WITH DAMPERS/FLUID FLOW CONTROL WITH VALVES**

Controlling the capacity of air/fluid that a system delivers by speed control is far more efficient than conventional methods of flow control such as discharge dampers/inlet guide vanes on fans or throttling valves on pump systems.

**USE A BOOSTER FAN/PUMP**

When a fan/pump is operating under a relatively high pressure differential, it may be possible to increase system efficiency and reduce power requirements by utilising a booster fan/pump to assist the main fan/pump. Check for pump systems that are operating in a series or in parallel. This may be an indication that the initially selected pump was of the wrong design or that the system's head capacity has changed significantly.

**REDUCE FAN/PUMP SPEED**

When the speed of a centrifugal fan or pump is reduced by 50%, the delivered flow is also reduced by 50% but the power required to drive that fan/pump may be reduced by up to 87.5%. Methods of decreasing the speed include installing a two-speed motor, making sheave or pulley changes, using a mechanical variable speed device, or installing an electrical VSD that is appropriate to the application at hand. Even small reductions in centrifugal fan/pump speed will result in large reductions in power. Figure 4.12 illustrates this savings opportunity.

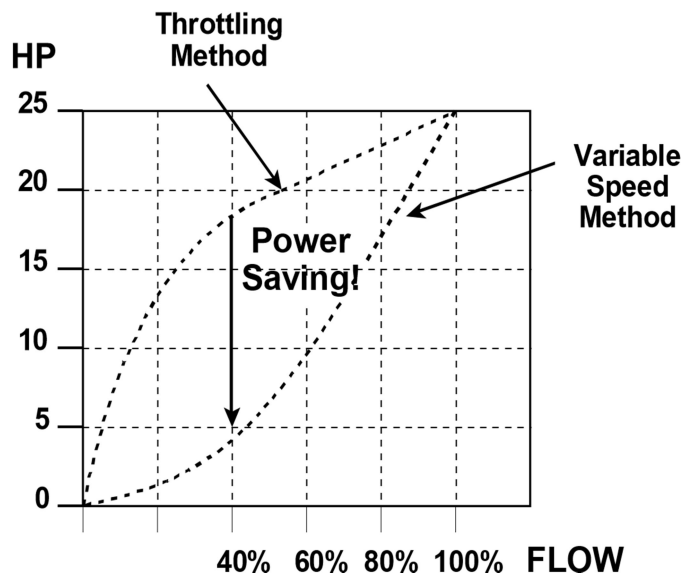

Figure 4.12: Power–flow relationship

**Example 4:** An energy audit was carried out for a fan. It was observed that the fan was delivering 16,000 Nm<sup>3</sup>/h of air with a static pressure rise of 55 mm water column. The power measurement of the 3-phase induction motor coupled with the fan recorded 2.1 kW/phase on average. The motor operating efficiency was assessed as 86% from the motor performance curves. What would be the fan static efficiency?

Solution

$$Q = 16,000 \text{ Nm}^3/\text{hr} = 4.444 \text{ m}^3/\text{s}$$

$$SP = 55 \text{ mm WC},$$

$$\eta_{st} = ?$$

$$\text{Power input to motor (for three phase)} = 2.1 \times 3 = 6.3 \text{ kW}$$

$$\text{Power input to fan shaft} = 6.3 \times 0.86 = 5.418 \text{ kW}$$

Fan static  $\eta$

$$= \frac{\text{volume in } \frac{\text{m}^3}{\text{s}} \times \Delta P_{st} \text{ in mm WC}}{102 \times \text{power input to shaft}}$$

$$= \frac{4.444 \times 55}{102 \times 5.418}$$

$$= 0.4423 = 44.23\%$$

Fan speed can be increased or decreased with a change in the drive pulley or driven pulley.

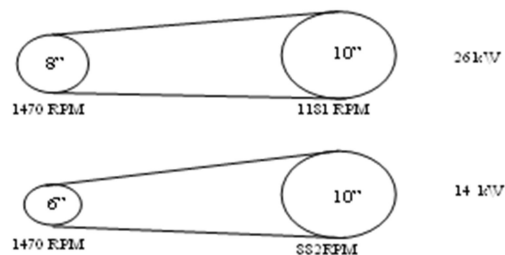

Pump efficiency explained using an example:

**Example 5:** Example: A centrifugal pump is pumping 70 m<sup>3</sup>/h of water with a discharge head of 5 kg/cm<sup>2</sup> and a negative suction head of 3 metres. If the power drawn by the motor is 16 kW, find out the pump efficiency. Assume motor efficiency as 90% and water density as 1000 kg/m<sup>3</sup>.

Solution:

$$\text{Hydraulic power } P_h = Q \text{ (m}^3/\text{s)} \times \text{total head, } h_d - h_s \text{ (m)} \times \rho \text{ (kg/m}^3) \times g \text{ (m/s}^2) / 1,000$$

$$Q = 70 / 3,600 \text{ m}^3/\text{s}, h_d - h_s = 50 - (-3) = 53 \text{ m}$$

$$\text{Hydraulic power } P_h = (70 / 3,600) \times 53 \times 1,000 \times 9.81 / 1,000$$

$$= 10.1 \text{ kW}$$

$$\text{Pump shaft power} = 16 \text{ kW} \times 0.9$$

$$= 14.4 \text{ kW}$$

$$\text{Pump efficiency} = \text{Hydraulic power} / \text{pump shaft power} = 10.1 / 14.4 = 70\%$$

## 4.6. POWER GENERATING EQUIPMENT: DIESEL, NATURAL GAS AND SOLAR PHOTOVOLTAICS

### DIESEL GENERATORS

The diesel engine is a type of internal combustion engine; more specifically, it is a compression ignition engine. The fuel in a diesel engine is ignited by sudden exposure to the high temperature and pressure of an oxygen-containing compressed gas (usually atmospheric air), rather than a separate source of ignition energy (such as a spark plug). This process is known as the diesel cycle after Rudolf Diesel, who invented it in 1892. Generator sets produce either single-phase or three-phase power. Most homeowners require single-phase power whereas industrial or commercial applications usually require three-phase power. Diesel engine generators are recommended due to their longevity and lower operating costs. Modern diesel engines are quiet and generally require much less maintenance than comparably sized gas (natural gas or propane) units.

#### » Diesel engine generators – industrial applications

Diesel generators are designed to meet the needs of small and medium-sized businesses apart from heavy usage in industries. Most modern generators are engineered to satisfy emergency power requirements. These units continuously monitor the electrical current and automatically start up if the power is interrupted and switch off when it returns. In industries, during critical processes, generators can supply emergency power to all vital and selected loads as desired.

#### ENERGY SAVING OPPORTUNITIES IN OPERATING DG SETS

1. Ensure steady load conditions on the DG set & provide cold and dust-free intake air.
2. Improve air filtration.
3. Ensure fuel oil storage, handling and operation as per the manufacturer's guidelines or oil company data.
4. Consider fuel oil additives.
5. Calibrate fuel injection pumps periodically.
6. Ensure compliance with maintenance checklists.
7. Ensure balanced electrical loading.
8. In the case of base load operations, consider a waste heat recovery system.

#### IMPACT OF UNBALANCED LOADING ON DG SET

Always try to keep loads as balanced as possible, since unbalanced loads can increase losses, elevate heating requirements and decrease efficiency. They also result in unbalanced output voltages. An unbalanced load between phases should not exceed 10% of the capacity of the generating sets.

**Example 6:** A diesel gen-set is operating at 800 kW load with 480°C exhaust gas temperature. The DG set produces 8 kg gas per kWh generated, and the specific heat of gas at 0.25 kCal/kg °C. After the installation of a heat recovery boiler, the exhaust gas temperature is reduced to 180 °C. How much steam will be generated at 3 kg/cm<sup>2</sup> with an enthalpy of 650.57 kCal/kg? Assume a boiler feed water temperature of 80 °C.

Solution:

Quantity of flue gas	= 800 x 8
	= 6,400 kg/h
Heat recovered	= 6,400 x 0.25 x (480 – 180)
	= 480,000 kcal/h
Quantity of steam generated	= 480,000 / (650.57 – 80)
	= 841 kg/h

**Example 6:** A 180 kVA, 0.80 PF rated DG set has a diesel engine rating of 220 BHP. What is the maximum power factor which can be maintained at full load on the alternator without overloading the DG set? (Assume alternator losses and exciter power requirement as 5.60 kW and there is no derating of the DG set.)

Solution:

$$\text{Engine rated power} = 220 \times 0.746 = 164 \text{ kW}$$

$$\text{Rated power available for alternator} = 164 - 5.6 = 158.4 \text{ kW}$$

$$\text{Maximum power factor possible} = 158.4 / 180 = 0.88$$

#### STEP-BY-STEP APPROACH FOR CONDUCTING AN ENERGY PERFORMANCE ASSESSMENT OF A DG SET ON THE SHOP FLOOR

The routine energy efficiency assessment of DG sets on the shop floor involves the following typical steps:

- 1) Ensure reliability of all instruments used for trial.
- 2) Collect technical literature, characteristics, and specifications of the plant.
- 3) Conduct a two hour trial on the DG set, ensuring a steady load, wherein the following measurements are logged at 15 minutes intervals:
  - a) Fuel consumption (by dip level or by flow meter)
  - b) Amps, volts, PF, kW, kWh
  - c) Intake air temperature, relative humidity (RH)
  - d) Intake cooling water temperature
  - e) Cylinder-wise exhaust temperature (as an indication of engine loading)
  - f) Turbocharger RPM (as an indication of loading on engine)
  - g) Charge air pressure (as an indication of engine loading)
  - h) Cooling water temperature before and after charge air cooler (as an indication of cooler performance)
  - i) Stack gas temperature before and after turbocharger (as an indication of turbocharger performance)
- 4) Refer to oil company data for the fuel oil/diesel analysis.
- 5) Analysis: The trial data is to be analysed with respect to:
  - a) Average alternator loading
  - b) Average engine loading
  - c) Percentage loading on alternator

- d) Percentage loading on engine
- e) Specific power generation in kWh/litre
- f) Comments on turbocharger performance based on RPM and gas temperature difference
- g) Comments on charge air cooler performance
- h) Comments on load distribution among various cylinders (based on exhaust temperature; temperatures ranging  $\pm 5\%$  of mean and high/low values indicate a disturbed condition)
- i) Comments on housekeeping issues like drip leaks, insulation, vibrations, etc.

### **NATURAL GAS GENERATORS**

Natural gas is often informally referred to simply as “gas”, especially when compared to other energy sources such as oil or coal. However, it is not to be confused with gasoline, especially in North America, where the term gasoline is often shortened to “gas” in colloquial usage.

#### **» Steam generation units**

Natural gas can be used to generate electricity in a variety of ways. The most basic natural gas-fired electric generation consists of a steam generation unit, where fossil fuels are burned in a boiler to heat water and produce steam that then turns a turbine to generate electricity. Natural gas may be used for this process, although these basic steam units are more typical of large coal or nuclear generation facilities. Basic steam generation units have a fairly low energy efficiency. Typically, only 33 to 35% of the thermal energy used to generate the steam is converted into electrical energy in these types of units.

#### **» Centralised gas turbines**

Gas turbines and combustion engines are also used to generate electricity. In these types of units, instead of heating steam to turn a turbine, hot gases from burning fossil fuels (particularly natural gas) are used to turn the turbine and generate electricity. Gas turbine and combustion engine plants are traditionally used primarily for peak load demands, as it is possible to switch them on both quickly and easily. These plants have increased in popularity due to advances in technology and the availability of natural gas. However, they are still traditionally slightly less efficient than large steam-driven power plants.

#### **» Combined-cycle units**

Many of the new natural gas-fired power plants are known as “combined-cycle” units. In these types of generating facilities, there is both a gas turbine and a steam unit, all in one. The gas turbine operates in much the same way as a normal gas turbine, using the hot gases released from burning natural gas to turn a turbine and generate electricity. In combined-cycle plants, the waste heat from the gas-turbine process is directed toward generating steam, which is then used to generate electricity much like a steam unit. Because of this efficient use of the heat energy released from the natural gas, combined-cycle plants are much more efficient than steam units or gas turbines alone. In fact, combined-cycle plants can achieve thermal efficiencies of up to 50 to 60%.



### » *Distributed generation*

Until recently, methods of generating power have been discussed in the context of large, centralised power plants. However, with recent technological advancements has come a trend towards what is known as “distributed generation”. Distributed generation refers to the placement of individual, smaller sized electric generation units at residential, commercial, and industrial sites of use. These small-scale power plants, which are primarily powered by natural gas, operate with small gas turbines or combustion engine units, or natural gas fuel cells.

Distributed generation can take many forms, from the small, low output generators used to back up the supply of electricity obtained from the centralised electric utilities to the larger, independent generators that supply enough electricity to power an entire factory. Distributed generation is attractive because it offers electricity that is more reliable, more efficient, and cheaper than purchasing power from a centralised utility. Distributed generation also allows for increased local control over the electricity supply, and cuts down on electricity losses during transmission. Below is a discussion of the various forms of natural gas-fired distributed generation.

Because of the extensive natural gas supply infrastructure and the environmental benefits of using natural gas, it is one of the leading choices for on-site power generation in Nigeria. There are a number of ways in which natural gas may be used on site to generate electricity. Fuel cells, gas-fired reciprocating engines, industrial natural gas-fired turbines, and micro turbines are all popular forms of using natural gas for on-site electricity needs.

### » *Industrial natural gas-fired turbines*

Industrial natural gas-fired turbines operate based on the same concept as the larger centralised gas turbine generators discussed above. However, instead of being located in a centralised plant, these turbines are located in close proximity to the future usage site of the electricity being generated. Industrial turbines produce electricity through the use of high-temperature, high-pressure gas to turn a turbine that generates a current. They are compact, lightweight, easily started, and simple to operate. This type of distributed generation is commonly used by medium-sized and large establishments, such as universities, hospitals, commercial buildings and industrial plants, and can achieve an efficiency of up to 58%.

In contrast with distributed generation, the heat that would normally be lost as waste energy can easily be harnessed to perform other functions, such as powering a boiler or space heating. Such installations are known as combined heat and power (CHP) systems. These systems make use of heat that is normally wasted in the electric generation process, thereby increasing the energy efficiency of the total system.

In addition, on-site natural gas turbines can be used in a combined-cycle unit, as discussed above. Due to the advantages of these types of generation units, a great deal of research is being put into developing more efficient, advanced gas turbines for distributed generation.

### » *Natural gas-fired reciprocating engines*

Natural gas-fired reciprocating engines are also used for on-site electric generation. These types of engines are commonly known as combustion engines. They convert the energy contained in fossil fuels into mechanical energy which rotates a piston to generate electricity. Natural gas-fired reciprocating engines typically generate an output ranging from less than 5 kW up to 7 megawatts (MW), meaning they can be used as small-scale residential backup

generators to a base load generator in industrial settings. These engines offer efficiencies from 25 to 45%, and can also be used in a CHP system to enhance energy efficiency.

Fuel cells are becoming an increasingly important technology for the generation of electricity. They are much like rechargeable batteries, except instead of using an electric recharger; they use a fuel such as natural gas to generate electric power even when they are in use. Fuel cells for distributed generation offer a multitude of benefits, and are currently an exciting area of innovation and research for distributed generation applications.

## **SOLAR PHOTOVOLTAICS**

### » *Global solar photovoltaic (PV) industry statistics*

Global solar photovoltaic capacity has grown from around five gigawatts in 2005 to slightly below 230 gigawatts in 2015, by which time cumulative solar PV installations had already reached some 35.7 gigawatts in Germany alone. The projected worth of the residential solar PV market in the United States was around 4.7 billion USD for 2016.

In 2013, the global market for solar photovoltaic manufacturing was sized at just over 90 billion US dollars, with China being the largest market for solar cells and modules. China was home to seven of the world's ten leading solar module manufacturers in 2015. In 2011, the country's share of the global photovoltaic market reached 50%, thus eclipsing the revenue generated by Germany's PV industry, which saw major companies leaving the market over the past four years, including Sunfilm and Q-Cells. As a result of the price war initiated by Chinese firms, the United States imposed anti-dumping tariffs against several Chinese manufacturers in 2012, while the European Union set a price floor on solar modules at EUR 0.56 (or approximately USD 0.74) in 2013.

### » *How solar cells work*

Sunlight is composed of miniscule particles called photons, which radiate from the sun. As photons strike the silicon atoms of the solar cell, they transfer their energy to "non-bonded" electrons, thus removing them from their orbital sphere. Photons could be compared to the white ball in a game of pool, which passes on its energy to the coloured balls it strikes.

Freeing up electrons is, however, only half the work of a solar cell: it then needs to "herd" these stray electrons into an electric current. This involves creating an electrical imbalance within the cell, comparable to a downward slope along which the electrons all move in the same direction.

Creating this imbalance is made possible by the internal organisation of silicon. Silicon atoms are arranged together in a tightly bound structure. By squeezing small quantities of other elements into this structure, two different types of silicon are created: n-type silicon, which has spare electrons, and p-type silicon, which is missing electrons, leaving "holes" in their place. When these two materials are placed side by side inside a solar cell, the n-type silicon's spare electrons jump over to fill the gaps in the p-type silicon. This means that the n-type silicon becomes positively charged, and the p-type silicon negatively charged, creating an electric field across the cell. Because silicon is a semiconductor, it can act as an insulator to maintain this imbalance.

As the photons "smash" the electrons off the silicon atoms, this charge field drives them along in an orderly manner, providing the electric current to power calculators, satellites and everything in between.

### » Efficiency

Electrical efficiency (also called conversion efficiency) is a contributing factor in the selection of a photovoltaic system. However, the most efficient solar panels are typically the most expensive, and may not be commercially available. Therefore, selection is also driven by cost efficiency and other factors. The electrical efficiency of a PV cell is a physical property which represents how much electrical power a cell can produce for a given insolation. The basic expression for the maximum efficiency of a photovoltaic cell is given by the ratio of output power to the incident solar power (radiation flux multiplied by area):

$$\eta = \frac{P_{\max}}{E \times A_{\text{cell}}}$$

The efficiency is measured under ideal laboratory conditions and represents the maximum achievable efficiency of the PV material. Actual efficiency is influenced by the output voltage, current, junction temperature, light intensity and spectrum.

The most efficient type of solar cell to date is a multi-junction concentrator solar cell with an efficiency of 46.0%, first produced in Germany in December 2014. The highest efficiencies achieved without concentration include 35.8% using a proprietary triple-junction manufacturing technology in 2009, and 40.7% also using a triple-layer design.

One of the major causes for the decreased performance of cells is overheating. The efficiency of a solar cell declines by about 0.5% for every one degree increase (in Celsius) in temperature. This means that a 100 degree increase in surface temperature could decrease the efficiency of a solar cell by about half. Self-cooling solar cells are one solution to this problem. Rather than using energy to cool the surface, pyramid and cone shapes can be formed from silica, and attached to the surface of a solar panel. Doing so allows visible light to reach the solar cells, but reflects infrared rays (which carry heat).

### » Photovoltaic panels and systems

Photovoltaic (PV) panels convert sunlight directly to electricity. Although sunlight is free and abundant, solar electricity is still usually more expensive to produce than large-scale mechanically generated power due to the cost of the panels. Low-efficiency silicon solar cells have been decreasing in cost and multi-junction cells with a conversion efficiency of nearly 30% are now commercially available. Over 40% efficiency has been demonstrated in experimental systems. Until recently, photovoltaics were most commonly used in remote sites without access to a commercial power grid, or as a supplemental electricity source for individual homes and businesses. Recent advances in manufacturing efficiency and photovoltaic technology, combined with subsidies driven by environmental concerns, have dramatically accelerated the deployment of solar panels.

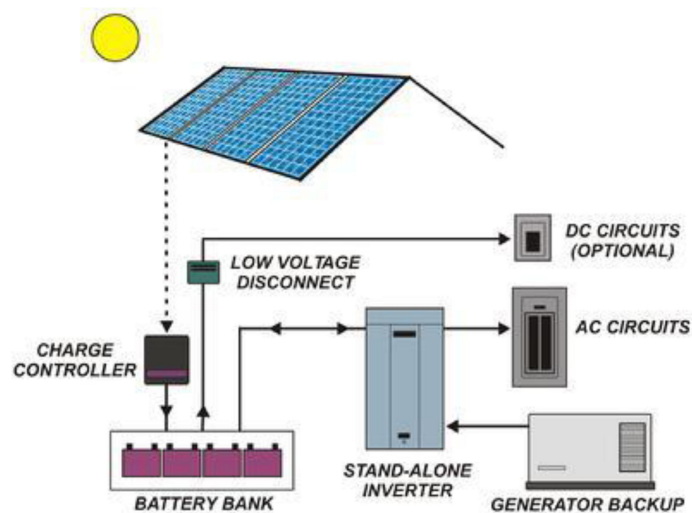

Figure 4.13: Stand-alone solar PV hybrid system setup

Solar PV systems can either be designed as stand-alone (no utility connection, with battery storage) or grid-connected (utility power for times when the PV system cannot supply electricity) installations. The latter type of installation makes it possible to feed electricity from the PV system into the grid in times of excess power. Significant growth of the global PV market has generated economies of scale, thus leading to a major decrease in PV prices.

» **Rooftop and building-integrated systems**

Photovoltaic arrays are often associated with buildings: either integrated in building structures, mounted on buildings, or mounted nearby on the ground. Rooftop PV systems are most often retrofitted onto existing buildings, usually mounted on top of the existing roof structure or on the existing walls. Alternatively, an array can be located separately from the building but connected by cable to supply power for the building. Building-integrated photovoltaics (BIPV) are increasingly incorporated into the roof or walls of new domestic and industrial buildings as a principal or ancillary source of electrical power. Roof tiles with integrated PV cells are sometimes used as well. Provided there is an open gap in which air can circulate, rooftop-mounted solar panels can provide a passive cooling effect in buildings during the day and also keep accumulated heat in at night. Typically, residential rooftop systems have small capacities of around 5 to 10 kW, while commercial rooftop systems often amount to several hundreds of kilowatts. Although rooftop systems are much smaller than ground-mounted utility-scale power plants, they account for most of the installed capacity worldwide.

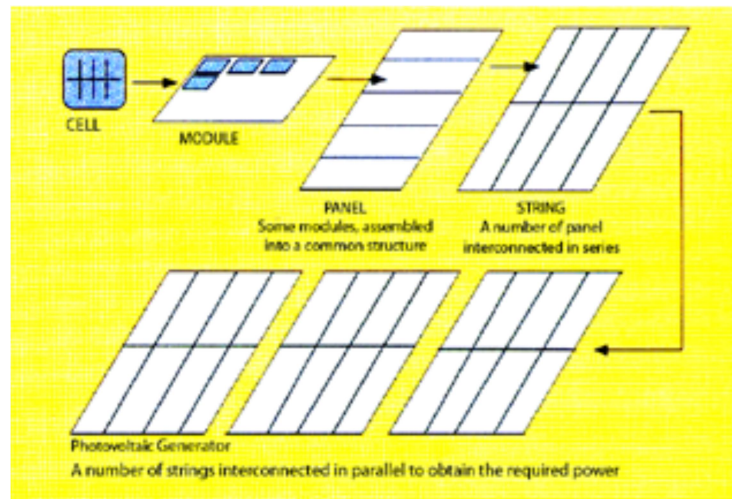

Figure 4.14: Solar PV system: Cell, module, panel, string

Inside modules the cells are encapsulated between two protective layers, which can be made of glass (glass–glass modules) or transparent plastic resins (transparent plastics–transparent plastics modules). Combinations exist with glass as the upper or front layer and transparent plastics as a backing layer (glass–transparent plastics modules) as well as with flexible or folding modules made of amorphous or thin-film microcells. Fixed modules are usually supplied with an aluminium frame around the circumference, used to suspend or attach modules to the supporting structures. A distribution/junction box with electric connections is located at the back of the panel.

**PROSPECTS FOR USE IN RURAL AREAS**

The development and distribution of solar and wind energy technologies are two high priority objectives, provided that such installations do not disturb the landscape and the existing habitat and that they be implemented in the best way possible. Today, the most promising semiconductor material generally used for the production of photovoltaic cells is silicon. It is used in various forms: as single-crystal, polycrystalline and amorphous silicon. The first two types of silicon have meanwhile become widespread options in the marketplace. In the electronics industry (semiconductors), where requirements for material purity are quite high,



single-crystal and polycrystalline silicon are manufactured in part by processing waste material.

In photovoltaics technology, these requirements are much lower. Silicon is widespread due to its reliability. Typically, its colour is blue but it can be produced in other colours as well – i.e. in the yellow, green and red range. Quite interesting is, moreover, the so-called “thin-film” technology for the production of photovoltaic cells, which takes the form of industrial-quality “sheets” with a thickness of some tenths of a millimetre. Some of these products are very light and flexible, which makes them suitable for non-standard installation conditions (e.g. uneven surfaces), as well as for car and boat installations and for the power supply of specific equipment (radiophones, battery charging, etc.). Solar cells are an intermediate product of the photovoltaic industry: their voltage and current levels are limited compared to those typically required by units. They are also very fragile and lack both electrical insulation and mechanical support. Solar cells are therefore installed in such a way that they form a complex structure. This structure is also known as a “photovoltaic module”, in other words, a “sandwich” comprising materials with good conductivity and resistance and a middle part which is the cell’s surface.

Modules are the major component of all types of photovoltaic systems. They are integrated into a structure called a panel. When modules are interconnected in a series, the total current becomes equal to that of the module generating the least current, the total voltage being the sum of the voltages of the individual modules. A number of modules interconnected in a series form a “string”. A number of strings interconnected in parallel make a “photovoltaic generator”.

Stand-alone installations are generally used to provide electricity to customers located in hard-to-access areas. As electricity consumption is usually limited in such regions, the costs for a connection with the power grid are not justifiable. Photovoltaic installations generally offer a more economical power-supply alternative at distances of over 3 kilometres from the existing electricity distribution grid. Currently, the following types of installations are most widely spread:

**FLAT PASSABLE ROOFS**

This type of roof can be found most often in larger residential areas mainly on reinforced concrete and/or steel structure buildings as well as multi-storey (multifunctional systems) and single-storey (mono-functional systems) structures. Undoubtedly, flat roofs are the most suitable option for photovoltaic system installations, as there are no restrictions to their orientation. Modules are installed onto individual support structures and the system can be set up at an optimum orientation to maximise annual energy generation. In terms of appearance, however, this option does not always offer the best solution.

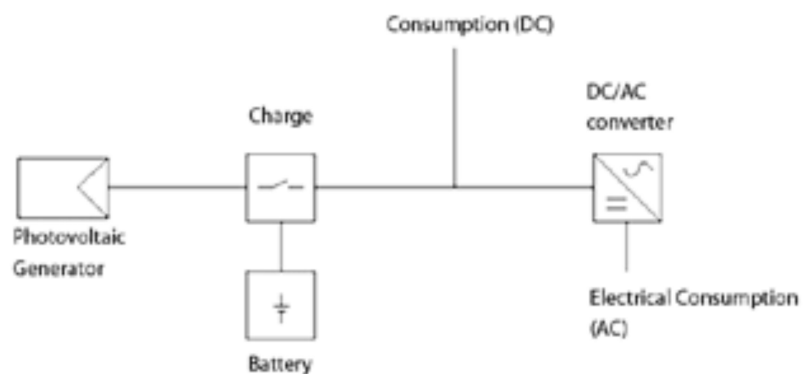

Figure 4.15: Isolated (stand-alone) system

## SLOPED TILE ROOFS

Sloped roofs covered with tiles are typical for geographic areas with severe winters and frequent snowfalls. Modules are installed onto the sloped roofs of buildings. The slope determines the efficiency of the installation and the energy yield can therefore be suboptimal. On the other hand, support structures may not be required. This option offers more pleasant aesthetics due to the visual harmony between the building and the installation.

### » *Facade systems*

Building facades can provide large areas and a high potential for very aesthetic installations, especially when combining photovoltaic systems with other components like glass surfaces. Building-integrated installations have various different advantages:

- They do not require special-purpose areas for installation and thus occupy surfaces that normally go unused. There is no additional impact on the environment. New areas are not occupied, as is the case with power plants, where modules are installed on the ground and arrays should be spaced far enough apart to prevent shading between rows. Ground modules occupy twice as much space as the useful surface on the module that generates energy from sunlight.
- Some materials used for supporting structures (typical features of power plants) can be avoided by using existing structures provided by the building. Moreover, part of the materials for covering a building can be replaced by photovoltaic cells, functioning in this case as a real roofing structure. Of course the savings mentioned above are obtained only when the photovoltaic system is designed simultaneously with the building and cannot be achieved in the case of modifications, i.e. subsequent changes to existing building structures.
- Integrated photovoltaic systems not only generate electricity but also improve and optimise energy flows between a building and the environment.

### » *Major components of a photovoltaic system*

The three major components of a photovoltaic system are modules, the inverter and the electric meter. A **module** generates electricity by converting sunlight into a constant type of electrical voltage, like the voltage in batteries. An **inverter** converts constant voltage into alternating voltage, i.e. similar to the domestic voltage used by household appliances (washing machines, TV sets, etc.). Grid-connected facilities are also equipped with an additional **electric meter**: the inverter converts direct current electricity generated by photovoltaic modules connected in series into alternating current. AC is then fed to the power grid, supplying the electrical installation of the consumer. An additional electric meter registers the redundant energy (i.e. energy not used by the consumer), which is then fed to the national electrical distribution grid.

### » *Sizing and energy output*

Photovoltaic cells are sized to meet the electricity requirements – in full or in part – of the consumers for whom they are installed. With stand-alone systems, batteries are designed and installed to meet 100% of the consumer electricity demand at any isolation status. With a grid-connected photovoltaic system, cells can be sized to meet a different percentage of electricity consumption as well as to generate more electricity than the required total; redundant electricity is then fed to the power grid.

Many parameters affect system sizing. One is electricity consumption (daily, monthly or annually). Selecting low-consumption devices such as special pumps and refrigerators, energy-saving lamps, etc., is an important measure. If the energy demand is low, a smaller photovoltaic system can be used, meaning a lower purchasing cost, more limited usage (daily, monthly, seasonally) and a smaller installation area. If more space is available, more adequate modules with lower conversion efficiency can be used. The geographic location of the installation (latitude), available sunlight (daily duration, intensity) and average ambient temperature are additional factors for system sizing.

To assist the sizing process, available sunlight should be assessed horizontally along with the light effectively captured by the respective module surface with its specific angle and orientation. Shadow assessment can be done using a diagram of sun trajectories. It is essential for the system to be exposed to the sun during most daylight hours throughout the year. A total consumption analysis goes through the following stages:

1. Assessment of the consumption of available electrical appliances as well as their maximum operating capacity.
2. Assessment of the possible interventions to reduce electrical consumption. Almost all interventions to save electricity and use high-efficiency appliances result in cutting the costs for a photovoltaic system. The use of photovoltaics is effective only when other consumption-reduction strategies are simultaneously applied. According to this approach, the assessment of a widely used photovoltaic system (in a residential dwelling, tourist site or small enterprise) can be unbiased (fair) only when the possible electricity-saving measures have been accounted for as well.
3. Assessment of optimised electric consumption.

For grid-connected photovoltaic systems, sizing is not as important as for stand-alone systems. The grid can also meet the consumer demand when there is no sunlight.

#### » **Conditions for installation: Functioning**

Photovoltaic modules can be located on any part of a building owned by a consumer. Their technical feasibility is determined by the installation site as well as by the following factors, which should be inspected in situ by the designer or installation engineer:

- Availability of the required area for module installation (useful area of about 8–10 m<sup>2</sup> kW<sub>p</sub> of installed capacity is required);
- Correct exposure and inclination of the area mentioned above.

For Italy, for example, the optimum conditions are southern exposure (southeast and southwest are also acceptable with a limited loss in productivity), an inclination angle of 30 to 35° and no obstacles for sunlight.

Main technical and architectural installation options:

- Modified location above the roof
- Incorporated in the roof
- On balcony
- Incorporated in vertical facade



» **Power grid connection**

Within the group of grid-connected systems, we can distinguish between power plants and building-integrated installations. Power plants feature a high capacity (from tens of watts to several megawatts) and they are designed for the centralised generation of electricity which then is supplied to a national or local grid. These are plants for electricity generation and supply. Integrated installations have recently gained great popularity and importance, with the possibility of connecting them to the electrical distribution grid making them even more significant. Integrated installations use building roofs and facades as the basic area for photovoltaic modules and aim at meeting the electricity demand of the consumers for whom they are installed (distributed generation). Therefore, they have a relatively low capacity (from several kilowatts to tenths of kilowatts). Grid connections enable more flexible sizing. With stand-alone systems, photovoltaics and storage batteries need to ensure the entire annual consumption of a consumer. However, with a grid-connected photovoltaic system, this is not necessary, because the power grid serves as a practically unlimited storage battery. Sizing can therefore be done on the basis of other parameters, like the available effective area on a given roof or the initial investment budget.

Integrated photovoltaic installations can be classified according to the location and arrangement of the modules on the roofing areas of a building. Within grid-connected systems, building installations have various advantages compared with power plants:

- Integrated systems generate electricity exactly where it is required, thus considerably reducing transmission losses, which can reach 7 to 10% in a single grid.
- Electricity generation during sunlight hours helps decrease demand from the grid during the day, this being the period of highest consumption. Assuming the large-scale development of photovoltaic system integration in newly constructed buildings, we can envisage an equalisation of the daily peaks in electricity demand curves corresponding to the most expensive periods of energy generation. This is an interesting alternative, particularly when considering the increasing use of air conditioning systems in residential and public buildings.
- Finally, the use of these systems is an incentive for the revival of better “energy awareness” among customers, which will have a positive effect on the current global energy situation as rational and efficient energy use becomes more indispensable.
- Customers who generate electricity and own installations will tend to use electricity more reasonably. Research has shown a considerable decrease in the amount of electricity consumed in dwellings where home owners had installed with photovoltaic installations.

**Note:** Recommended measures for saving energy in electrical applications must be serviceable by the on-site technical team of the client. They must be financially viable to ensure cost savings reducing expenditure of the client.

## 5. ENERGY EFFICIENCY IN BUILDINGS

### *About this module*

This module explores the gains of energy-efficient buildings in accordance with existing standards. Trainees will learn the fundamentals of building energy management and proper methods for achieving energy gains.

### *Learning outcomes*

At the end of this module, the participant is able to

- Describe the fundamentals of building energy management
- Appreciate the importance of building management systems (BMS)
- Identify energy consumer groups in a building
- Collect and analyse data gathered
- Develop, analyse and recommend energy conservation measures
- Prepare, present and defend proposals
- Implement measures

### 5.1. ELEMENTS OF THE BUILDING ENERGY MANAGEMENT PROCESS

#### **BUILDING ENERGY MANAGEMENT SYSTEMS**

##### » *Residential sector*

The share of the residential sector in TFC for Nigeria in 2011 was almost 80%. This share is an estimate from International Energy Agency (IEA) energy statistics and should be used with caution as a preliminary indication of the weight of the residential sector relative to the other sectors, as there may be difficulties separating the consumption of the residential sector from the services sector for several end uses and energy forms.

While the share of the residential sector in TFC varies widely from country to country, so do the shares of the respective energy sources consumed in this sector. Globally, the residential sector consumes almost a quarter of world TFC, but it accounts for the consumption of 74% of biomass, 30% of natural gas, 27% of electricity and only 6% of oil.

##### » *Energy management system (EnMS)*

The development of an energy policy is the starting point for effective energy management. Although some companies and municipalities may already have taken action to reduce their energy bill, few have recognised the need for structured and formalised measures that start with an energy policy. Steps to developing such a policy include:

- Discussing the strengths and weakness of the energy system,
- Understanding interdependencies of individual departments,
- Discussing possible future developments
- Being aware of the strong dependency on fossil fuels and external suppliers.

Experience shows that when developing an energy policy, staff must have a clear understanding about why such a document is needed in the first place as well as the benefits it is likely to bring. The development of an energy management system (EnMS) is an elaborate and time-consuming process, so staff must be motivated to play an active role. For staff

members to participate, they must be convinced that this extra work will result in actual advantages.

» *EnMS within the company/municipality*

In the first place it is important to visualise the energy consumption to establish a common understanding about key figures. As data about losses, weaknesses and strengths is often unavailable, the Energy Manager should focus on these areas (i.e. where no data is available and no information could be collected). In the beginning, invoices are often the first and only available source that provides an overview of the energy system. Focusing on black boxes like a “company” or a “municipality” might lead to the realisation that additional work is necessary to understand the actual costs, consumption, losses and improvement potentials.

Staff members are the most important resource for the realisation of saving potentials. Adopting and maintaining best practices in the workplace can result in a 20% reduction in total energy. It is therefore essential to involve staff in the development of policy statements. As this can be a very time-consuming process, it might be a good idea to contact staff via a short questionnaire before the actual policy statement is drafted. Survey staff members regarding areas in which losses occur and strategies that could be implemented to increase energy efficiency. The results then may be used to formulate the policy.

After brainstorming, discuss contributions to reach a common understanding. Summarise and distribute statements for additional comments and suggestions. Explaining individual statements and consequences in greater detail can also be helpful.

The project group then decides about the last modifications and prepares the final policy, which senior management will then be asked to officially sign and support. Management is responsible for implementing the energy policy at the company and the document in question presents guiding principles.

At least one of the following strategies should be chosen and implemented:

- Energy policy on notice boards
- Energy policy in company/municipality magazine
- Policy presentation in direct meetings
- Policy-related articles in local newspapers and trade publications
- Email signatures

Energy systems, factors influencing their management (EnMS) and the organisations in which they are found are never in a static state but instead continuously changing. An energy policy is therefore not set in stone; it must be adapted from time to time. Energy Managers must be aware that the policy must be revised in the following situations:

- Changes in the external pressures on the company/municipality, e.g. introduction of new legislation (e.g. emissions trading), changing markets
- Corporate changes, e.g. company merger
- Site changes, e.g. introduction of a new product range or production process
- Changes in stakeholder pressures, e.g. growing public concern about a particular issue

### » *EnMS documentation*

The primary purpose of energy management documentation is to provide a good description of the energy management system. The energy management manual should act as a permanent reference for the implementation and maintenance of the system.

### » *Energy management manual*

Documentation of policy, objectives and targets, management programmes, key roles and responsibilities, and the interaction of system elements is a necessary part of a management manual. The energy management system does not need to be contained in a single manual. It should provide references to other documentation containing more specific information on individual EnMS components. It can also point to related documentation, which may include the following items:

- Description of the management system, detailing its scope and purpose and its relationship to the organisation's energy policy, objectives and targets
- Copy of the energy policy
- Organisational objectives and targets
- Organisation chart, depicting the organisational structure with respect to energy management. This should include a list of the names of current job holders
- Criteria for assessing significant energy consumers
- List of significant energy consumers
- Register of legislative, regulatory and other policy requirements
- List of procedures and work instructions with energy relevance (detailed documents may be annexed)
- Description of the organisation's energy management programmes
- Description of the system for keeping energy management records
- Arrangements for regular audits, including reports or references to the location of reports
- Arrangements for management reviews

### » *Document control features*

- Date stamped (including revision dates).
- Readily identifiable, for example by named procedures, clear reference numbers, specified ownership, etc.
- Maintained in an orderly and easily referenced manner, i.e. by systematically providing numbered and lettered references to individual procedures, schedules, etc.

### » *Communication*

Data about the energy management system (EnMS), quantities and costs should be user-friendly or they will likely be ignored. Each target group requires dedicated information and its presentation has a strong influence on whether the information will be immediately forgotten or whether it has a lasting impact on behaviour.

Reports should be compiled for a well-defined target group. General reports or very detailed reports are not often widely read. Before a report is compiled, the following should be considered:

- Who needs this information?
- What kind of information is necessary?
- How should the information be provided?
- When should the information be provided?

There are several methods to present information and each method has its advantages and disadvantages. It is up to the Energy Manager to decide which method is the most suitable for his/her organisation. Mixing methods is also a good idea to keep things interesting. The following methods may be used to present energy data:

1. Indicators
2. Information in text form
3. Information in tables
4. Graphs
5. Symbols and pictures

**Indicators** are a helpful instrument to trace a company's energy performance. Absolute indicators present the development of the total energy consumption. Relative indicators are built with reference units and take into account the development of the organisation. It is common practise to use relative indicators in order to be able to compare different systems and their performance over time.

**Information in text form** may be seen in more detailed reports, analyses and descriptions. Information and data in text form may not be the best way to attract and keep the reader's attention. Therefore, text-only presentations should be avoided if the Energy Manager's primary goal is staff motivation.

**Information in tables** should be used for qualified staff. This presentation format can be very confusing for staff members who have never dealt with topics such as energy consumption and energy savings – especially if quantities are expressed in kWh or m<sup>3</sup>.

Tables must be explained in detail. Staff members need guidance in terms of where to focus, which figures are relatively high or low and whether improvements are possible. In addition, the Energy Manager should consider whether staff members truly require a comprehensive overview or whether it would be better to focus on specific areas.

**Graphs** are easy to compile and provide clear visuals. Nonetheless, it is important to

- Keep data to a minimum
- Label the axes,
- Find a clear title and – if possible – focus on a selected area.

Also consider providing a short description to explain the graph.

Remember: energy cannot be seen, so visuals are important. Provide support by showing staff where energy gets used and which appliances are the biggest offenders.

Describing quantities with **pictures and symbols** will help staff remember the key statements. It is a fact that managers rarely use such drawings and pictures, as they believe they will not be perceived as serious and "tough". However, especially in an area where the information itself is very technical, care must be taken to avoid materials that are completely devoid of inspiration. Make sure to tailor your communication to your audience. Your choice

of media – such as an energy report – to convey and disseminate information should depend on the size of the company/municipality and the strategy in place. Use a joint approach that combines technology and communications for more effective energy savings.

» **Structure of an energy report**

An energy report should be compiled on a regular basis and summarise all activities and data about the energy consumption of the past period. The main goal of the report is to inform management about the energy management system. The findings should be presented to top management, including planned activities and the budget required to increase energy efficiency. Reports may include the following components:

**EXECUTIVE SUMMARY**

- Motivation for developing an energy report
- Main findings and areas of improvement

**INTRODUCTION**

- Overview of the company/municipality

**ENERGY PRICE & DEVELOPMENT**

- Suppliers and their delivered energy prices
- Description of energy prices for the past 5 years and outlook for the coming year
- Description of the price structure

**TOTAL CONSUMPTION**

- Cost structure of the company (staff, energy, investments, capital)
- Energy consumption for the last 5 years
- Energy benchmarks (energy consumption/product; energy consumption/m<sup>2</sup>)
- Energy production and re-use of energy

**ENERGY CONSUMPTION OF INDIVIDUAL AREAS**

- Building
- Infrastructure
- Production

## 5.2. ENERGY CONSUMER GROUPS

In Nigeria the MYTO II tariff categorises five customer groups: residential, commercial, industrial, special and street lighting, over the 11 distribution zones (11 distribution companies). These groups are further divided into subclasses. Every class is assigned a separate fixed charge.

### CONSUMER GROUPS AND CONSUMPTION

» **Electricity and consumption**

Currently, the percentage of residents with electricity access in Nigeria is relatively low. According to official statistics less than half of the population is connected to the national grid (60.4% in urban areas and 16.1% in rural areas). In other words, most households across the country are not served by the national grid network, meaning that the majority of rural and poor households do not receive electricity from the national grid.



Household energy usage is intimately linked to the lifestyle and associated cultural and demographic factors of inhabitants. These factors are very subjective and not easily defined with precision.

Nonetheless, there are broad patterns or trends discernible amongst households in particular regions of the country (e.g. more cooling in hot northern states, more industrial activities in the southwestern states).

When taking a broad account of the typical daily activity schedules of Nigerian households based on demographics, the following activities make up the bulk of energy demand: cooking; water heating; lighting; brown goods (TV, computers, etc.); refrigeration and various other electrical appliances. This activity mix is also changing with the increasing use of solar panels and inverters.

The huge metering gap across the industry is a major issue. Energy efficiency would go a long way in closing the demand–supply gap and much can be done to reduce consumption, especially for the residential and commercial class (behavioural changes) and the industrial class (machine retrofits). The average percentage of metered customers in the above-mentioned 11 distribution zones was about 48% in 2011.

**Table 5.1: Power usage by the average Nigerian household**

	<i>Capacity</i>	<i>Operating time/day</i>	<i>Energy consumption/month</i>
Incandescent bulb	50 W	6 hours	9 kWh
Water heater	2,000 W	30 minutes/ day	30 kWh
Microwave oven	1,000 W	Avg. 3 hours/day (multiple uses)	5 kWh
Laptop	100 W	Avg. 8 hours/day	15 kWh
Ceiling fan	75 W	Avg. 7 hours/day	15.75 kWh
Kettle	2,000 W	Avg. 30 min/day (multiple uses)	10 kWh
Iron	1,000 W	Avg. 1 hour / day	30 kWh
Split air con	950 W	8 hours/day	228 kWh
Fridge	600 W	24 hours	432 kWh

A study conducted in Jos (mid-sized city) suggests the typical Nigerian household has three distinct demand peaks (with little difference between weekdays and weekends), namely:

- 6 am – 9 am (water heating, cooking, lighting)
- 2 pm – 3 pm (cooking, air conditioning)
- 8 pm – 9 pm (cooking, air conditioning, entertainment, lighting)

» *Behavioural sources of electricity wastage*

Energy consumed in Nigeria could be drastically reduced through the replacement of incandescent bulbs with energy-efficient bulbs. Households can reduce energy used for lighting by approximately 80 to 90% with LED lamps. Energy efficiency policies should be implemented to encourage a gradual phasing out of incandescent bulb and discourage the importation and production of incandescent bulbs. Policies can also encourage the importation and local production of energy-efficiency light bulbs as well as reduce the cost of these bulbs through subsidies. Awareness is also needed to change the attitude of Nigerians regarding the need to save energy through the use of corresponding technologies. The FMENV's De-



partment of Climate Change has outlined how energy efficiency potentials can help mitigate the climate change impact of Nigeria's energy system.

#### **INCANDESCENT LIGHT BULBS**

The introduction of compact fluorescent light (CFL) bulbs results in a negative incremental cost of USD 58 per tonne CO<sub>2</sub>, with a 5.155-million tonne CO<sub>2</sub> reduction capacity. However, this potential will become more attractive if LED is preferred over CFL.

Incandescent light bulbs are commonly referred to as "yellow bulbs" by many Nigerians because of the yellowish colour of their light rays. A study from 2009 revealed incandescent bulb use among 65% of the respondents. Anytime an incandescent bulb is switched on, only about 5% of the total energy input is converted to light energy while the remaining 95% is converted to heat energy. Thus, the incandescent bulb can be more aptly described as a heater than as a light source. In the Nigerian market, the energy rating of incandescent bulbs ranges from 40 to 200 W.

#### **AIR CONDITIONERS**

Between 2006 and 2014, a total of 24 million air conditioning units (domestic, commercial and industrial) were imported by Nigeria, the majority for domestic use. Air conditioners make up a substantial share of household electricity consumption. A recent GIZ report suggests the Nigerian market is far from saturated and the stock of air conditioners will continue to increase.

#### **WASTEFUL DAYTIME LIGHTING**

Many Nigerian small businesses are in the habit of using light to advertise their goods and services during daytime hours. This is a common tactic among retailers of electrical goods and fast food centres. Some use incandescent light bulbs to keep food warm and, at the same time, draw people's attention to their products. A lot of energy could be saved if Nigerians would stop using artificial lighting in the daytime. The government can require large and medium-sized firms and public buildings to carry out energy audits on a regular basis to enable the designated agency to tax them. Energy audits should be performed by government-designated agencies or external firms to ensure transparency. The government can also encourage medium and large privately owned firms to create energy management units before they register their business with the government.

#### **USE OF PRIVATELY OWNED WATER BOREHOLES**

Water scarcity in Nigeria has encouraged the use of privately owned water boreholes. The equipment used in boreholes for pumping water from the aquifer is energy-intensive and can consume up to 2,000 W of electricity. In many parts of the world, water is conveyed from a central system through a network of pipes to residential, public and private buildings. This method significantly reduces the energy required to extract water from the ground and make it available to people. Government policy can be designed in this sense to encourage a centralised water provision system for citizens.

#### **IMPROPER TOWN PLANNING**

Improper planning is a problem that affects many Nigerian cities. The practice of building industries in residential areas is unhealthy for power supply systems. Local and state governments should support and institute policies that will encourage support the proper planning of towns and cities to promote the efficient use of energy.

**STANDBY MODE**

Electrical equipment consumes energy when in standby mode. Manufacturers of electrical appliances should inform consumers that their products consume energy on standby. Labels attached to appliances can be used as an effective means to communicate this information. Government policy should ensure that energy labels provide adequate and comprehensive information to consumers.

**MULTIPLE APPLIANCES IN PUBLIC BUILDINGS**

Many public buildings such as universities, hostels and offices are not metered; thus users of these facilities are not accountable for the energy they consume.

There may be need for governments to formulate policy that encourages the users of public buildings to reduce their electricity use. Public and private institutions should develop their own energy management policies that will restrict the use of certain appliances. Governments can obligate public and private building owners to conduct energy audits and furnish the details to the relevant agencies.

**APPLIANCES NOT IN USE**

Electrical appliances (USD 16/tonne) and wood-stoves (USD 3/tonne) have recently seen some advances and improvements in the residential sector (9.566 m tonne CO<sub>2</sub> reduction capacity).

Many citizens do not switch off their appliances when not in use. This practice encourages the wastage of electricity, since the actual consumption of these devices tends to be forgotten.

**SOLAR WATER HEATERS**

A recent GIZ study concludes that solar water heaters (SWH) for domestic application and electric heaters yield roughly the same energy cost savings. One reason is that the SWH market is not yet well developed in Nigeria and hence prices are high. The second reason is that the electricity tariffs in Nigeria are comparatively low (although rising according to the MYTO 2.1 regulation). The situation is similar in educational institutions and hospitals. Therefore, incentives, grants, and financing models are needed to make SWHs more attractive for potential users.

On the other hand, the study also reveals that the use of SWH is profitable in hotels, even without subsidies. Results show a theoretical payback period of 3 to 10 years. However, most hotels have decentralised water-heating systems that make retrofits with SWH systems more difficult.

» *Largest energy savings potential: Hot water heating, cooling and lighting*

Compared to other countries, Nigeria shows a relatively high energy use per unit of GDP. This can hardly be influenced by reducing the price of grid electricity, given that the electricity supply from the grid is erratic and diesel generators, an alternative fuel source, are comparatively expensive throughout the country. The low absolute consumption figure is indicative of the lack of generating capacity. The high relative energy use, however, is clearly a point where energy efficiency measures could pay off.

As an example, the 2010/2011 General Housing Survey provides data on the distribution of households based on main lighting fuels. Most households rely on kerosene as their main lighting fuel, followed by electricity, battery/dry cell and firewood, respectively. Based on

these figures, one can assume that electricity consumption for lighting will increase as more and more households are connected to the electricity supply.

An analysis of energy savings potential conducted in 2013 reveals that hot water heating, cooling and lighting hold the most promise at the household level.

Looking at the end-user side, some 26.8% of the total per household energy consumption could be saved with the introduction of solar water heaters (whereby this does not consider energy for pumping water). Secondly, estimates reveal that the total energy requirement could be reduced by an additional 6.7% if the average energy consumed by cooling systems were decreased through shading, insulation, timer switches, etc. Thirdly, the introduction of energy-saving lighting sources would produce a net energy savings of around 6% per household. All in all, measures taken in this regard would garner energy consumption reductions of close to 40%.

However, inadequately trained personnel and professionals is another factor inhibiting the development of energy efficiency in Nigeria. Out of the 150 respondents interviewed in the study conducted by Community Research and Development Centre in 2009, 77% stated that no member of their organisations had received energy management training.

### 5.3. TARIFF EVALUATION

#### ENERGY COST

##### » *Off-grid electricity prices*

In the present set-up of the Nigerian electricity market, off-grid generation based on medium-sized diesel gen-sets is by nature far more expensive for the consumer than the on-grid supply of electricity. The World Bank estimates the cost for generation with medium-sized diesel gen-sets at approx. USD 250/MWh (corresponds to USD 0.25/kWh). This is significantly higher than the electricity charges for residential usage and also higher than electricity charges of USD 0.124–0.185/kWh for industrial usage, purchased from the DISCOs based on MYTO 2.1. Small-scale businesses and families spend an average of USD 21.8 billion annually to power their generating sets with diesel and petrol due to the unstable electricity supply.

Most strikingly, electricity generated by solar PV is expected to fall to a level similar to that for small hydropower plants, with the cost of diesel/solar hybrid systems falling proportionately.

Notably, to date, solar PV is already substantially cheaper than electricity produced using diesel generator sets. This especially is the case in areas located at long distances from diesel depots – which includes most parts of northern Nigeria. This trend seems to be persistent, considering various international predictions of the PV prices compared to other means of power generation. Fossil fuel prices, particularly in Nigeria, are expected to rise more than in other (comparable) economies, due to expected cuts in subsidies. Taking these circumstances into consideration, solar PV plants broke even with diesel generator sets much earlier than predicted in studies. Solar PV/diesel hybrid systems can thus be expected to gain sway over time.

However, if customers begin to understand the tendency for electricity prices to rise in the future, they may start to adopt more energy-efficient habits.

» **Grid electricity prices**

In Nigeria, grid electricity prices are controlled by the Nigerian Electricity regulatory commission (NERC). Electricity tariffs are stated in the Multi Year Tariff Order II (MYTO II) which sets electricity prices up till 2018 for all classes of consumers. The MYTO specifies 5 consumer groups namely: Residential (R), Commercial (C), Special (D), Industrial (A), Street lighting (S).

Tariff classes		
Customer Classification	Description	Remarks
<b>Residential</b>		
R1	Life-Line (50 kWh)	A consumer who uses his premises exclusively as a residence- house, flat or multi- storied house
R2	Single and 3-phase	
R3	LV Maximum Demand	
R4	HV Maximum Demand (11/33 KV)	
<b>Commercial</b>		
C1	Single and 3-phase	A consumer who uses his premises for any purpose other than exclusively as a residence or as a factory for manufacturing goods.
C2	LV Maximum Demand	
C3	HV Maximum Demand(11/33 KV)	
<b>Industrial</b>		
D1	Single and 3-phase	A consumer who uses his premises for manufacturing goods including welding and ironmongery
D2	LV Maximum Demand	
D3	HV maximum Demand (11/33 KV)	
<b>Special</b>		
A1	Single and 3 Phase	Customers such as agriculture and agro-allied industries , water boards, religious houses, government and teaching hospitals, government research institutes and educational establishments.
A2	LV Maximum Demand	
A3	HV Maximum Demand (11/33 KV)	
<b>Street Lighting</b>		
S1	Single and 3-phase	2

Figure 5.1: Tariff classes according to MYTO II

For more information, visit the NERC website on: [www.nercng.org](http://www.nercng.org)

**5.4. ENERGY EFFICIENCY INDICATORS**

In Nigeria, a great deal of energy is wasted because households, public and private offices, as well as industries use more energy than is actually necessary to fulfil their needs. One of the reasons is that they use outdated and inefficient equipment and production processes.

**ENERGY PERFORMANCE OF BUILDINGS**

» **Energy efficiency: Costs, certification and consumption**

Writing a clear definition of “energy efficiency” is no easy task. In fact, it is often easier to define criteria that make something more (or less) energy efficient than to define energy efficiency itself. For instance, something is more energy efficient if it delivers more services for the same energy input, or the same services for a smaller energy input. People can define energy efficiency using one of two perspectives: a service perspective or a mechanical perspective. And, in fact, energy efficiency leads to important social benefits, such as reducing the energy bills of poor households.

**ENERGY COSTS AND CONSUMPTION**

Costs and consumption depend on the:

- Cooling system (higher maintenance equals lower heating/cooling costs)
- Building structure (well-insulated buildings have lower costs)
- Outdoor climate
- Fuel price

**CERTIFYING ENERGY EFFICIENCY**

An energy efficiency certificate is a summary of the building's energy audit. It is meant to give information on the building's energy consumption and its energy efficiency rating. The purpose of energy efficiency certificates is to:

- Inform tenants and prospective buyers of the expected running costs;
- Create public awareness;
- Define prerequisites to improve energy efficiency;
- Effect incentives, penalties or legal proceedings.

Which information should be displayed on energy performance certificates, and how it should be interpreted is a key issue. In order to facilitate comparisons between buildings, the energy performance certificate should include reference values such as current legal standards as well as benchmarks and recommendations for cost-effective investments which can be undertaken in the building to improve its energy performance.

The empirical and modelled benchmarks mentioned above are used to indicate how a particular building compares to the rest of the stock. These benchmarks are used for two ratings normally displayed on the energy performance certificates – the asset rating and the operational rating.

***Asset rating***

Modelled benchmarks are typically used to rate the intrinsic performance potential of the building and contribute to the building's asset rating. This is a rating of the standard of the building fabric and building services equipment and is based on theoretical values.

***Operational rating***

Empirical benchmarks are typically used to rate the in-use performance of the building—the operational rating. This will be influenced by the quality of the building (as measured by the asset rating), but also by the way the building is maintained and operated. The operational rating is based on actual metered energy consumption, normalised in some way to account for the effects of building size, pattern of use, weather, etc.

To supplement certification, in some European countries regular inspection of heating and air conditioning systems to assess their efficiency and sizing compared to the heating and cooling requirements is carried out.

**ENERGY EFFICIENCY INDICATORS**

Energy efficiency indicators can be highly aggregated, for example, total appliances/average energy consumption per appliance (e.g. average heating consumption per floor area of single houses using natural gas for heating). Indicators are usually composed of an energy consumption unit as a numerator and activity data as a denominator.



Energy consumption can be expressed in various units (kWh, joule, tonnes of oil equivalent, etc.), while activity data cover a wide range of activities: production of cement, floor area, passenger-kilometres, employees, etc., expressed in as many units as activities (tonnes, square meters, kilometres, number of employees, etc.).

Particularly in large commercial office buildings, high heat loads are developed through lighting, computing and other electrical sources. Further heat gains are derived from occupants, solar radiation and high outdoor temperatures. These factors make cooling of indoor air essential.

When choosing a cooling method, the choice is between mechanical cooling and ventilation cooling. In either case, heat gains should be minimised by a good building design and reduced power consumption. Mechanical cooling is energy intensive and contributes to peak power loads. When mechanical cooling is needed, ventilation must be minimised to prevent the unnecessary loss of conditioned air.

Cooling appliances account for a large percentage of the energy we consume in our homes and offices. It has been found that cooling accounts for about 44% of the average domestic utility bill. Home owners can reduce energy spent on cooling by investing money in proper insulation and weathering. The insulation of walls and loft spaces alone can help reduce heat loss/gain by over 50% and prevent wasted energy.

By combining proper equipment maintenance and upgrades with insulation, weatherisation and thermostat setting, energy consumption can be reduced drastically.

$$\text{Energy efficiency indicator} = \frac{\text{Energy consumption}}{\text{Activity data}}$$

Energy efficiency indicators are computed at the end-use or sub-sectoral level, or at an even more disaggregated level, that is, the unit energy consumption level. For example, within the residential sector, energy consumed by space heating per unit floor area is an energy efficiency indicator at the end-use level, and energy consumed per unit of appliance is an energy efficiency indicator at the unit consumption level.

#### » *Energy intensity*

The specific parameter to measure the energy consumption required for a certain product or unit is energy intensity. The energy intensity is the ratio of energy consumption in relation to the reference metric. The main reason for measuring the energy intensity is that it is readily available, since it is the ratio of the total primary energy supply (TPES) divided by the gross domestic product (GDP).

As a consequence, since TPES and GDP are numbers that are easily obtained for any country, energy intensity is often used as a proxy for energy efficiency. This is a mistake; however, since a given country with a low energy intensity does not necessarily have a high efficiency. For instance, a small service-based country with a mild climate would certainly have a much lower intensity than a large industry-based country in a very cold climate, even if energy is more efficiently consumed in the second country than in the first.

Efficiency is a contributing factor in intensity, but many other elements – and often more significant factors – also need to be considered. These include: the structure of the economy (e.g. presence of large energy-consuming industries); the size of the country (higher/lower demand from the transport sector); the climate (higher/lower demand for cooling); and the exchange rate.

### » *Natural energy gains*

Natural energy gains include passive cooling, natural ventilation, and daylight. Intelligent maximisation of natural energy gains can significantly reduce the energy that must be delivered to meet a building's needs. Environmentally smart buildings make intelligent use of energy resources while minimising waste.

Natural energy gains can be maximised by exploiting the potential contribution to a building's performance offered by the site and its surroundings through:

- Building plan which places functions in locations that minimise the need for applied energy;
- Shape which encourages the use of daylight and natural ventilation, and reduces heat losses;
- Orientation that takes account of the potential benefits from solar gains while reducing the risk of glare and overheating;
- Effective use of natural daylight combined with the avoidance of glare and unwanted solar gains;
- Natural ventilation wherever practical and appropriate, with mechanical ventilation and/or air conditioning used only to the extent they are actually required;
- Good levels of thermal insulation and prevention of unwanted air infiltration through the building envelope;
- Intrinsically efficient and well-controlled building services, well-matched to the building fabric and to the expected use.

This is best achieved at the building's design stage but can also be done during refurbishment.

### » *Delivered energy*

This is the amount of energy supplied to meet a building's net energy demand to provide energy for applications such as heating, cooling, ventilation, hot water and lighting. Delivered energy is usually expressed in kilowatt hours (kWh) and the main energy carriers are electricity and fuel, i.e. gas, oil or biomass for boilers. Delivered energy can be supplemented by on-site renewable energy in the form of solar PV, solar water heaters or wind.

### » *Exported energy*

This is the fraction of delivered energy that, where applicable, is sold to external users.

### » *System losses*

System losses result from inefficiencies in transporting and converting delivered energy, i.e. of the delivered energy, only 90% may actually be used to provide the actual services, e.g. lighting, cooling or ventilation, due to the inefficiency of the equipment used. When addressing the energy efficiency issue in buildings, the main focus is on the energy used to attain the required indoor climate standards. The amount of energy required by a building to attain these standards is dependent on:

- Building properties, i.e. whether the building is designed to minimise the need for applied energy depending on outdoor climatic conditions;
- How efficiently the delivered energy is used to meet the building's net energy demand, i.e. the efficiency of the equipment and appliances used;



- How efficiently energy is used by building occupants;
- Percentage of the building's energy requirement that is supplied by renewable energy.

» *Determining a building's energy performance*

#### ENERGY USE INDICATORS

The calculation of energy use in buildings is based on the characteristics of the building and its installed equipment. It is structured in three levels as illustrated below and the calculation is performed from the bottom up.

*Step 1* is the calculation of the building's net energy requirements, i.e. the amount of energy required to provide the indoor climate requirements as specified by the building code. The calculation is used to determine the net energy required based on the outdoor climate and indoor climate requirements while considering the contributions from internal gains, solar gains and natural lighting as well as losses due to building properties, i.e. heat transmission and airflows (air infiltration and exfiltration). This calculation is used to determine the intrinsic energy performance of the building.

*Step 2* is the determination of the building's delivered energy, i.e. the energy performance of the building in actual use. This is the amount of energy used for heating, cooling, hot water, lighting, ventilation systems, controls and building automation, and includes the auxiliary energy needed for fans, pumps, etc. Energy use is broken down and recorded for the individual energy applications and fuel types.

*Step 3* is the determination of the overall energy performance indicators: It combines the results from step 2 above for the different energy applications and fuels to obtain the overall energy use and associated performance indicators. Since a building can use more than one fuel (e.g. gas and electricity), the different energy sources have to be converted and combined in terms of primary energy to provide the optional end result of the calculation of energy performance. Commonly used energy indicators for buildings are kWh/m<sup>2</sup> (energy consumption in kilowatt hours per meter square of floor area) or CO<sub>2</sub> emissions.

For the purposes of this calculation, buildings are classified into categories depending on whether they are residential or non-residential, the type of building design and the building size and use. In addition to calculating the performance of existing buildings, energy performance calculations are also undertaken for new buildings at the design stage and for refurbished buildings to simulate energy performance following modifications.

It is the government's responsibility to provide, at the national or local level, calculation guidelines and methodologies for determining energy performance. In most instances, software is developed for these calculations.

## 5.5. ENERGY EFFICIENCY MEASURES FOR BUILDINGS

Energy efficiency measures for buildings are approaches through which the energy consumption of a building can be reduced while maintaining or improving the level of comfort in the building. They can typically be categorised into the following reductions: cooling demand; energy requirements for ventilation; energy use for lighting; energy used for heating water; electricity consumption of office equipment and appliances; as well as good house-keeping and people solutions.

## REDUCING ENERGY CONSUMPTION

### » *Reducing cooling demand*

Energy use in most air-conditioned office buildings is approximately double that of naturally ventilated office buildings. The need for air conditioning or the size of installed systems can be reduced by:

- Controlling solar gains through glazing;
- Reducing internal heat gains;
- Making use of thermal mass and night ventilation to reduce peak temperatures;
- Providing effective natural ventilation;
- Reducing lighting loads and installing effective lighting controls.
- Use of cool roofs.

### » *Avoiding excessive glazing*

Windows should be sized to provide effective daylight while avoiding excessive solar gains. Large areas of glazing will increase solar heat gains in summer and heat losses in winter, making it more difficult to provide a comfortable internal environment.

### » *Use of shading*

Solar gains can be reduced by the use of external shading, mid pane blinds (where blinds are integrated between the panes of the double or triple glazing unit) or by internal blinds. Internal blinds are the least effective method of controlling solar gains, as the heat will already have entered the space. External blinds are the most effective but may be difficult to maintain and are less easily adjusted for controlling glare. Mid pane blinds often provide an effective compromise. They can be raised when solar gains and glare are not an issue or lowered when required. High angle summer sun can be controlled on south facing elevations by the use of overhangs and fixed shading devices. Solar gains on east and west glazing are more difficult to control and will require adjustable shading devices. Other materials like the spray polyurethane foam-based (SPF) roof systems offer a decent R-value and reduce solar gains.

### » *Solar control glass*

Glazing is available with a range of selective coatings that alter the properties of the glass; ideally, glazing should be selected with the highest light transmittance and the lowest solar heat gain factor. This will help provide daylight while reducing solar gains. All major glass manufacturers provide data on the properties of their products, including those with coatings as described here.

### » *Selecting equipment with reduced heat output*

To reduce cooling demands, you can select office equipment with a reduced heat output and ensure that the equipment has effective controls with automatic switch-off when not in use. Flat screen monitors can significantly reduce heat gains, while at the same time reducing energy use and using office space more effectively. These benefits usually compensate for the higher cost of flat screen monitors.

» *Separating high heat load processes from general accommodation*

Where a building includes energy-intensive equipment such as mainframe computers, these are best located in a separate air-conditioned space, avoiding the need to provide the required level of cooling for the computers to the whole building.

» *Making use of thermal mass and night ventilation to reduce peak temperatures*

Thermal mass is the ability of a material to absorb heat energy. High-density materials such as concrete, bricks and tiles need a lot of heat energy to change their temperature. They are therefore said to have a high thermal mass. Lightweight materials such as timber have a low thermal mass.

Thermal mass is particularly beneficial where there is a big difference between outdoor temperatures during the day and at night. Correct use of thermal mass can delay heat flow through the building envelope by as much as 10 to 12 hours, producing a warmer indoor climate at night in winter and a cooler climate during the day in summer. High-mass buildings need to gain or lose a large amount of energy to change their internal temperature, whereas lightweight buildings require only a small energy gain or loss. Allowing cool night breezes or convection currents to pass over the thermal mass in these buildings will draw out all the stored energy.

» *Reducing heat gains from lighting*

Heat gains from lighting can be reduced by making best use of natural daylighting and by providing energy-efficient lighting installations with effective controls.

» *Predicting the impact of passive cooling strategies*

Computer simulation tools can be used to predict the likely comfort conditions in buildings and optimise glazing and shading arrangements.

» *Reducing the energy requirements for ventilation*

When the cooling demand is sufficiently reduced by implementing the above measures, it may be possible to reduce heat gains so that air conditioning is not necessary and comfort conditions can be maintained through the use of natural ventilation. The energy required for ventilation can be minimised by:

- Building design that maximises natural ventilation;
- Effective window design;
- Use of mixed mode ventilation;
- Using efficient mechanical ventilation systems;

**USE OF A COOL ROOF**

The last point refers to a roof with the ability to reflect and reject heat. Cool roof surfaces have both high solar reflectance and a high emittance

(emittance: the energy radiated by the surface of a body per second per unit area) (reflectance: rejecting heat back to the environment).

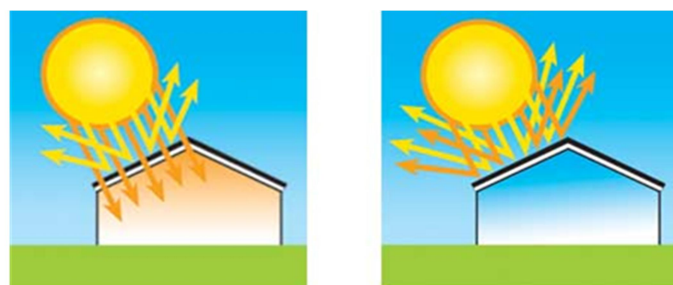

Figure (a) Conventional Roof

(b) Cool Roof

Figure 5.2: Use of cool roof

**Note:** For all recommended measures to have the desired impact, they must fall within the financial capability of the client. Recommendations must be financially attractive and technically feasible for them to make meaning to the client.

## 5.6. BUILDING DESIGN

The most effective form of natural ventilation is cross ventilation, where air is able to pass from one side of a building to the other. Effective cross ventilation typically dictates that buildings can be no more than 12 to 15 metres in depth. However, in deeper plan spaces, natural ventilation can be achieved by introducing central atria and making use of the “stack effect” to draw air from the outer perimeter and up through the centre of the building.

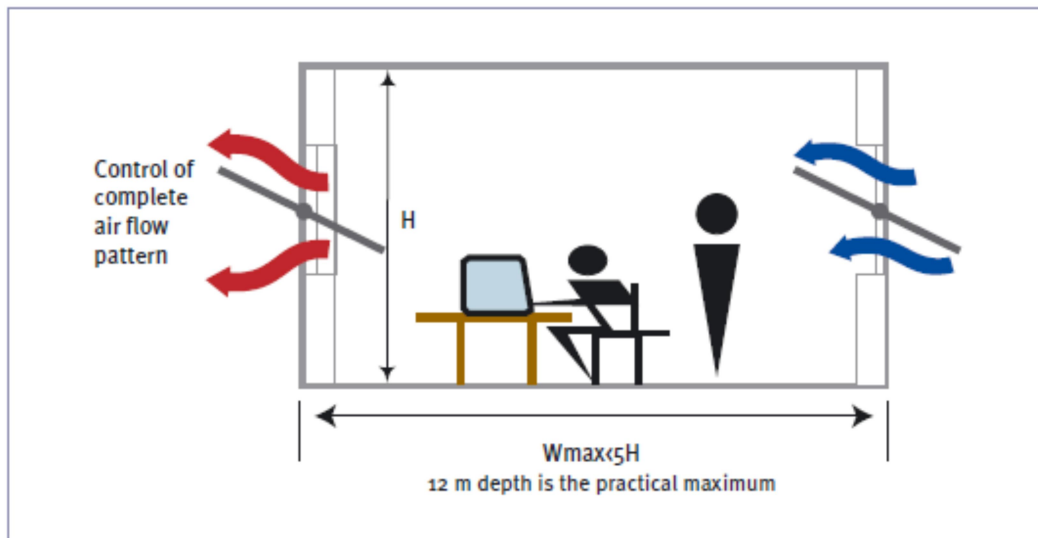

Figure 5.3: Cross ventilation

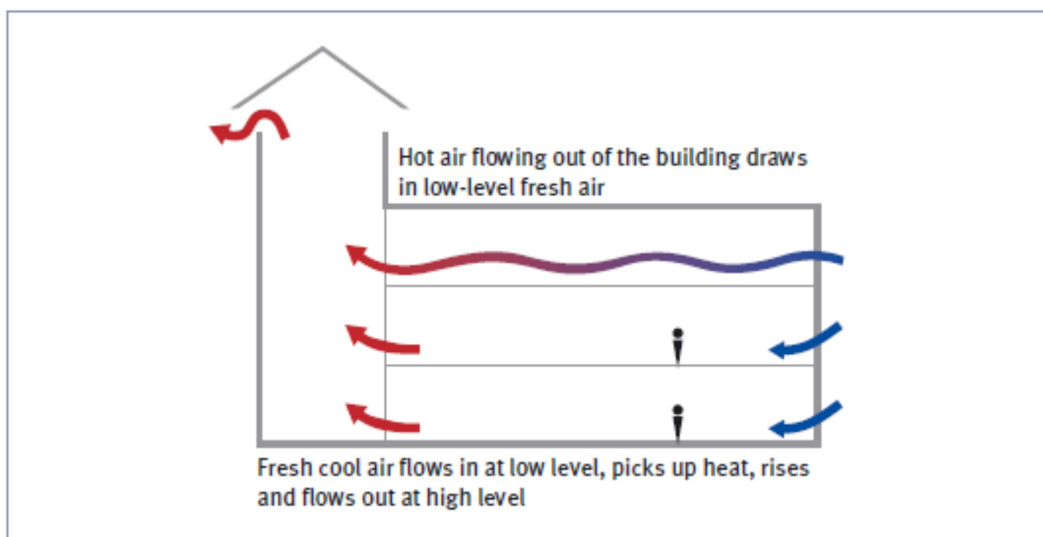

Figure 5.4: Stack effect

## PASSIVE ARCHITECTURE

### » *Examples for reducing energy consumption by improved ventilation, window design and lighting*

#### EFFECTIVE WINDOW DESIGN

Windows should allow ease of control by building occupants and controlled ventilation that will not blow papers off desks, or cause draughts.

Night ventilation can be an effective method of maintaining comfort conditions in summer. Where night ventilation is used, it is important that building occupants understand how the building is intended to operate, or that effective control measures be introduced, as it is counter-intuitive to open windows before leaving a building at night. Other factors to consider include maintaining security, and controlling the ingress of wind and rain. In some cases, high ambient noise levels or air pollution may prohibit the use of natural ventilation.

#### MIXED MODE VENTILATION

Mixed mode ventilation strategies allow natural ventilation to be used for most of the year or to serve parts of a building. Mechanical cooling is used to deal only with peak design conditions in summer or to serve areas of the building that experience a higher accumulation of heat.

#### REDUCING ENERGY USE FOR MECHANICAL VENTILATION

The main energy consumers for both mechanical cooling and for air conditioning are the fans needed to circulate air. To reduce energy use by fans for mechanical ventilation you can:

- Design the system to reduce pressure drops.
- Select efficient fans.
- Utilise variable speed fans to respond to varying load requirements.
- Avoid excessive air supply volumes.

#### REDUCING ENERGY USE FOR LIGHTING

This can be accomplished by following these guidelines:

- Maximise use of daylight while avoiding excessive solar heat gain.
- Use task lighting to avoid excessive background luminance levels.
- Install energy-efficient luminaires with a high light output to energy ratio.
- Select lamps with a high luminous efficacy.
- Provide effective controls that prevent lights being left on unnecessarily.

#### MAXIMISING THE USE OF DAYLIGHT

Introducing natural light into buildings not only saves energy but also creates an attractive environment that improves the well-being and comfort of building occupants. The provision of effective daylight in buildings can be assessed using average daylight factors and by ensuring that occupants have a view of the sky.

The average daylight factor will be influenced by the size and area of windows in relation to the room, the light transmittance of the glass, the brightness of internal surfaces and finishes, the depth of reveals, and presence of overhangs and other external obstructions which may restrict the amount of daylight entering the room.

Window design has a key impact on natural lighting. As a very general rule of thumb, a window will introduce effective daylight into a room at a depth that is twice the head height of the opening. High ceilings and clerestory windows can be effective in providing good daylight. Sun pipes and skylights can be used to introduce daylight to windowless areas.

#### **ENERGY-EFFICIENT LIGHTING SYSTEMS**

An efficient lighting installation should be able to provide the required illuminance level for a particular use with minimal energy consumption. As a general rule, efficient lights should provide illuminance levels of 500 lux on a working plane for less than 12 W/m<sup>2</sup> of installed power. Lux is the SI unit of illuminance. It is used in photometry as a measure of the intensity of light per square metre. Achieving an illuminance of 500 lux might be possible in a home kitchen with a single fluorescent light fixture with an output of 12,000 lumens. Lighting a factory floor with an area several times that of the kitchen would require dozens of such fixtures.

#### **LIGHTING CONTROLS**

Lighting controls should be designed so that small groups of lights can be controlled individually with controls provided adjacent to the work area. Perimeter lighting should be controlled separately from core lighting so that perimeter lights can be switched off when adequate daylight is available. Intermittent use spaces should be equipped with presence detectors that automatically switch lights off after a set period of time if a room or space remains unoccupied. Daylight sensors and timed switches should be used to prevent unnecessary use of external lighting. Daylight sensors can also be used to switch off internal lighting when daylight levels are sufficient.

#### **» Reducing energy used for heating water**

This can be achieved by:

- Installing time controls and setting them to correctly reflect the hours of hot water use;
- Setting sanitary hot water thermostats to the appropriate temperature – no more than 60°C for normal requirements (but ensure that hot water does not drop below 56°C);
- Switching off electric heating elements (immersion) when hot water from the boiler is available;
- Switching off any associated pumps when hot water is not required;
- Replacing any damaged or missing insulation from all hot water pipework and cylinders, except where the pipes are supplying useful heat to the space;
- Identifying a suitable hot water system.

Hot water is either supplied via a central generation plant, with a distribution network for provision to the required areas within a building, or by localised provision at the point it is required. In the case of localised hot water systems, water is heated and stored locally or it is provided on demand. The most significant reduction in energy use for hot water can be achieved by providing solar water heating.

#### **» Reducing consumption of office equipment and appliances**

Most businesses rely on a range of office equipment for their operations. From the basic essentials such as computers, monitors, printers, fax machines and photocopiers to projectors,



scanners and teleconference facilities, it is widely recognised that these items have become integral to daily business activity.

Office equipment is the fastest growing energy user in the business world, consuming 15% of the total electricity used in offices. This is expected to rise to 30% by 2020. There are also associated costs that are often overlooked, specifically those of increasing cooling requirements to overcome the additional heat this equipment produces. As ventilation and air conditioning are themselves major energy consumers, it makes good business sense to ensure they are only used when absolutely necessary.

Typical measures to reduce consumption which also apply to household appliances include:

- Switching off: Turning off devices or enabling power down mode reduces their energy consumption as well as the heat they produce, which in turn lowers cooling costs.
- Upgrading existing equipment: Some energy-efficient appliances may cost more to buy but will recoup savings over the lifetime of the equipment.
- Matching the equipment to the task: Consider current and predicted requirements and purchase equipment accordingly.
- Taking advantage of energy labelling schemes: Some well-known energy labelling schemes are Energy Star, European ecolabel scheme, Energy Saving Trust Recommended and the Market Transformation programme.

» *Good housekeeping and people solutions*

The level of achievable energy savings from office equipment often comes down to everyday management by staff. A simple energy conservation programme for an organisation would consider:

- Setting up an energy policy for the organisation;
- Appointing an energy champion;
- Involving staff;
- Setting targets;
- Using notices and reminders;
- Conducting walk-rounds;
- Taking meter readings.

**SETTING UP AN ENERGY POLICY**

Commitment to energy efficiency has to come from the top and should be backed by a personalised mission statement and energy policy. It is also important to appoint an energy champion. In very small businesses, this may be the owner or manager but in larger companies, an appointed staff member will often improve involvement and awareness across the whole organisation. Demonstrate management's commitment by developing a procurement policy that requires the special identification of energy-efficient products when purchasing.

**INVOLVING STAFF**

All staff members play an important role in saving energy, so they must be made aware of wastage areas and be trained to operate equipment and controls correctly. Motivating staff includes measures such as asking for opinions and encouraging people to review their own working practices to increase energy savings. The best ideas usually come from people who use the equipment on a daily basis. Competitions, campaigns and team projects are great

ways to get buy-in for this objective. Reinforce the benefits of improving the working area and give staff a sense of ownership of energy management.

#### **SETTING TARGETS**

Tell staff how much energy is currently being consumed and set a realistic savings target. As the energy saving programme gathers momentum, it will be possible to track progress and highlight energy savings.

#### **USING NOTICES AND REMINDERS**

Use notices and reminders for turning off equipment. They can also be used to highlight how less device use makes the working environment more pleasant.

#### **CONDUCTING WALK-ROUNDS**

Carry out regular good housekeeping walk-rounds in your building to find out where energy is being used. Note down when equipment is being used and act on any wastage or maintenance measures needed. As patterns of energy use vary throughout the day, it is advisable to carry out a series of walk-rounds at different times to get a better idea of where and when energy is being wasted. Walking around your office after everyone has left, before everyone comes in and when offices are empty during the day will give you an idea of which equipment tends to be left on after office hours.

#### **TAKE METER READINGS**

Meter readings can provide an overview of energy usage at the office. Meter readings can be used to determine electricity use during and after office hours. These figures will let you know how much energy is used every hour the office is empty. You can also find out how much energy is used when no one is in the building. In most offices, overnight energy consumption should only be a small percentage of the overall energy use.

#### *» Investments in energy efficiency in buildings*

Investments in energy efficiency in a building can be compared with the cost of capital investments necessary on the supply side of the energy system to produce a similar amount of peak capacity or annual energy production. Usually, the capital costs of efficiency are lower than comparable investments in increased supply and there are no additional operating costs of efficiency compared to substantial operating costs for supply-side options. In addition, energy efficiency investments generally have much shorter lead times than energy supply investments, a particularly important consideration in countries where the demand for energy services is growing rapidly.

The building sector is consistently subject to a high degree of regulation. Building codes often influence material use and appliance standards that have a significant effect on energy efficiency. Regulatory regimes, to the extent that they exist, may therefore provide a pathway to improve efficiency for both building construction and a variety of building appliances.

### **5.7. RETROFITTING HOMES AND PUBLIC BUILDINGS**

The practice of retrofitting homes and public buildings is now common in many parts of the world to reduce energy consumption. Because many homes and public buildings are older and equipped with all kinds of inefficient appliances, owners and governments are now increasingly choosing to replace this old equipment with newer and more efficient models. Be-

low, we discuss some ways individuals and organisations can improve energy efficiency in home and offices.

#### » *Lighting*

Many households and offices spend far more than necessary on energy for lighting. Energy spent for lighting can be reduced by about 60 to 80% by replacing incandescent bulbs with energy-saving bulbs such as compact florescent lamps (CFLs) and light-emitting diodes (LEDs). CFLs and LEDs are much more efficient than incandescent bulbs and they last six to ten times longer. Incandescent bulbs have been banned in some parts of the world. One good example is Cuba, where the Cuban Government banned the use of incandescent bulbs and also developed programmes to phase out these bulbs. Below is a simple computation to demonstrate that huge savings can be achieved by replacing incandescent lighting with energy-saving bulbs. When one million 60-watt incandescent bulbs are each replaced with 15-watt energy saving lamps, the resulting savings is 45 MW.

For outdoor lighting, timers can be used to help switch off lights automatically at a specified time.

#### » *Refrigeration*

Modern and energy-efficient refrigerators can help save much more energy compared to refrigerators that were designed 15 years ago. In many parts of the world, energy-efficient refrigerators are replacing older, inefficient models. It should also be noted that refrigerators are designed for different climates; some refrigerators are designed for temperate regions while others are designed for tropical regions. Using a refrigerator designed for the temperate region in a tropical climate will lead to an inefficient use of energy. Refrigerators should be used in the climate foreseen by their design. In Nigeria, the use of second-hand refrigerators from Europe should be discouraged, because these refrigerators may be designed for a temperate climate.

#### » *Landscaping*

There are natural ways we can keep our homes comfortable and reduce our energy bill. Trees can help reduce the energy we spend on cooling by providing shade to keep our home cool. Landscaping is a natural and beautiful way to maintain a comfortable indoor climate and reduce energy consumption by up to 25%. Apart from adding aesthetic value and eco-friendly quality to your home, greenery such as trees, shrubs or vines can deliver effective shade and reduce wind.

#### » *Providing incentives*

Various incentives for purchasing energy-efficient products have been employed to change the behaviour of consumers in a way that promotes energy efficiency. Such strategies have proven effective in a variety of places worldwide. Policies can be designed to penalise the use of inefficient products and reward the purchase of highly efficient appliances.

#### » *Renewable energy technologies*

The use of renewable energy technologies (RETs) can help reduce electricity consumption. For instance, households and hotels can use solar water heaters to reduce the amount of electrical energy spent on heating water. Solar water heaters have been developed and used in residential settings in other parts of the world. The use of RETs will be discussed in a subsequent chapter.

» **Energy Star – energy-efficient equipment and appliance labels**

Products with an Energy Star label are the same or better than standard products, only they use less energy. To earn an Energy Star, products must meet strict criteria for energy efficiency. More information on these criteria is provided in the next section.

## 5.8. REFERENCE STANDARDS (LOCAL AND INTERNATIONAL)

### ENERGY EFFICIENCY, STANDARDS AND LABELS (S&L)

» **Policy tools to promote building efficiency**

The most effective programmes are designed not only to ensure that a particular target level of energy efficiency improvement is realised but also to assure that the market is prepared to continually introduce better and better technologies for energy efficiency. Continuous improvements in energy efficiency should be anticipated in the developmental process for energy efficiency codes by requiring that the codes be reviewed periodically – such as every three or four years – and updated to include requirements for the use of newer technologies that are both cost-effective and feasible. There must be laws mandating that large energy consumers conduct an energy audit every four years, with permissible emission targets set depending on annual consumption (in MWh).

Legislative and policy options that have had some record of success in promoting energy efficiency in buildings include:

- Codes and standards for new constructions and performance-based economic incentives to exceed the standards;
- Long-term incentives with ambitious energy efficiency targets;
- Normative labels to distinguish the most energy-efficient buildings and equipment;
- Informative labels that provide the information necessary to measure energy efficiency and annual energy costs for operation;
- Education and outreach to promote market acceptance of energy efficiency technologies and energy-efficient designs, most notably efficiency demonstration centres;
- Government-funded research and development on energy efficiency in buildings.

» **Codes, standards and labels**

Codes refer to mandatory energy efficiency requirements for new construction in buildings. New construction refers either to an entirely new building being erected, or the construction of a new energy-using system (such as a lighting system or an air conditioning system) in an existing building. Standards refer to minimum mandatory requirements for equipment used in buildings, such as air conditioning units, furnaces or boilers, water heaters, office equipment, appliances, etc.

Energy efficiency standards are a set of procedures and regulations that prescribe the minimum energy performance of manufactured products. Energy efficiency labels are informative labels affixed to manufactured products. Such labels indicate a product's energy performance and efficiency in a way that allows for a comparison with similar products or endorses the product's use. Standards and labels (S&L) are meant to help the market recognise energy efficiency and act on it.

Standards can be set to ensure that obsolete and inefficient technology does not continue to dominate the market, much more effectively than is possible by the actions of individual end-users. Low-income households are often inclined to buy the cheapest product on the market. This burdens these users with much higher running costs for years to come, and countries with the need to invest higher amounts in energy supply networks than would be necessary if all products complied with minimum energy performance requirements. No one customer or manufacturer alone can alter this situation.

Governments, however, with technical support, can implement standards and labelling programmes that protect the poor from such purportedly cheap yet in reality highly expensive products, at a limited cost, and protect the manufacturers of highly efficient products from competitors who saturate the market with these expensive “cheap” products.

Due to the efficiency they achieve, standards and labels mean fewer investments in additional power plants and less fuel consumed in the generation of electricity. The result is economic gains (e.g. freeing up capital for investments in non-energy social infrastructure like schools, roads or hospitals) and environmental benefits (e.g. avoiding carbon emissions).

In addition, environment benefits will be realised through significantly reduced greenhouse gas emissions: according to recent estimates, compared to “business as usual” almost 204 million tonnes of CO<sub>2</sub> will have been saved from 2005 to 2020.

Benefits from more energy-efficient products extend beyond their direct impact on energy bills for households and businesses. Reducing peak demand improves grid reliability, affording better and more stable power to marginal users. Moreover, the harmonisation provided by S&L in the face of appliance globalisation reduces trade barriers, thereby reducing appliance prices for consumers relative to other commodities and making energy services more affordable to the economically disadvantaged.

#### » *Retail pricing of efficient appliances*

Before the introduction of standards and especially mandatory comparison (or endorsement) labels, consumers do not usually pay a premium for energy-efficient products. Consequently, the supply chain does not specify energy efficiency, and there is little correspondence between efficiency and product prices.

In the absence of an energy-efficiency programme, it is not uncommon to find products with the same price but very different energy efficiency characteristics. Even after the introduction of EE S&L, prices for products with varying energy performances may not differ a lot. An analysis of the European market for refrigerators demonstrated that the price for products in all energy classes varied only marginally, with the exception of the highest energy class. Furthermore, prices of energy-efficient products tend to go down over time. This shows that it is possible to achieve considerable energy savings at little initial cost to consumers as well as important financial benefits over the lifetime of products.

#### » *Benefits of energy-efficient S&L programmes*

Well designed and well implemented S&L programmes compare favourably to other governmental energy policies. Some advantages include:

- Extremely high energy savings potential, estimated at USD 100 billion for the USA by 2020;

- Excellent effectiveness in terms of delivering energy savings, reductions in greenhouse gas emissions, as well as significant financial gains to consumers and society;
- Manageable change, i.e. these programmes require change in the behaviour of a manageable number of manufacturers rather than all consumers in a society;
- Creation of a level playing field with equal treatment of all manufacturers, distributors and retailers; governments impose performance requirements instead of prescribing specific technologies;
- International enactment and scope increase harmonisation between major trade blocks and form part of a global approach; and
- Relative reliability in terms of energy savings, easy verification.

Setting standards and providing information to consumers will mean that all consumers obtain appliances which save money over the product lifetime, in most cases at little or no additional cost to the household. This leads to a better use of resources, resulting in a more efficient economy and lower costs for individual households.

#### » *Residential and non-residential buildings*

All major energy-related choices – the thermal conductivity of insulation, the thermal transmission qualities of windows, the heat capacity of building materials, the solar heat transmission qualities of windows, the visible light transmission of windows and the building envelope in general, the air and water movement output of fans and pumps, the efficiency of motors, heat transfer efficiencies of heaters for air and water, etc. – must be determined by standardised measurements. Before advanced energy-efficient equipment requirements can be determined for either a mandatory or a voluntary programme, test protocols and labelling rules must be established and enforced. For energy efficiency in buildings, the most effective codes offer two compliance options: prescriptive and performance-based compliance.

#### **PRESCRIPTIVE STANDARDS**

These standards refer to predefined requirements for the components of a building, for example, the thermal conductivity of insulation or the efficiency of a heating or cooling device. They do not offer the designer the flexibility to deviate from many of these minimum specifications.

#### **PERFORMANCE-BASED STANDARDS**

This set of standards, on the other hand, defines maximum values for energy consumption or annual projected energy costs for a building as a whole. Performance-based standards allow the designer to specify less energy efficiency in some components in return for more efficiency in others. They are more economically efficient because they allow the designer or builder to optimise the selection of efficiency measures to minimise initial investment costs. They also tend to lead to innovations in which actual efficiency measures exceed those required by prescriptive standards.

In addition to establishing protocols for the testing of buildings and components and the regulation of minimum acceptable levels of performance, the regulator must develop plans for the implementation and enforcement of standards. These can be more difficult to establish at first, since the goal is to establish a positive feedback cycle in which compliant companies and individuals receive positive reinforcement in the marketplace, whereas their non-compliant counterparts face potential penalties. Once it is established that a code will be enforced, it is not difficult to maintain these positive expectations, but a jurisdiction must plan



to make significant initial efforts to enforce the code with credibility. Certain categories of buildings may be exempted from these standards, e.g. buildings and monuments designated officially as protected (listed buildings or heritage sites), places of worship, temporary buildings destined for short-term use (two years or less), non-residential agricultural buildings with low energy demands, buildings whose useful floor area is below a certain range (e.g. less than 1,000 square metres).

#### » *Incentives*

Economic incentives serve as a complement to codes and standards. They depend on the prior existence of standards both to establish the criteria by which superior performance can be measured and to establish levels of efficiency at which economic incentives are justified. In turn, incentives can complement standards by providing for differentiation in the marketplace, e.g. the ability to distinguish between low efficiency, average efficiency and high efficiency when referring to buildings or products. Incentives can also encourage the widespread use of new technologies that may later be appropriate for standards, but which cannot be required at a given time due to questions of availability or the impossibility of universal application.

Although incentives are often more effective than regulation, they must be balanced against the need to provide a financial revenue source for the incentives. Standards require a dramatically smaller investment by the government to produce a given level of energy efficiency. They also guarantee that at least basic efficiency will be met in all applicable cases. Legislation establishing programmes for energy efficiency incentives must provide a funding mechanism for the incentive as well as an administrative mechanism for spending the money in the most effective way.

#### » *Certification and labelling*

Labels can typically be classified as normative or informative.

##### **NORMATIVE LABELS**

Normative labels mark products or buildings that achieve an “exemplary” or recommended level of energy efficiency above that of average efficiency levels. Normative labels can be established as an independent government programme, or as private sector programmes. Government policy can make use of normative labels by requiring that products purchased by the government directly or on government contracts qualify for the appropriate label.

##### **INFORMATIVE LABELS**

Information labelling as a policy tool can be a meaningful part of energy efficiency policy. It can encompass new and existing buildings or be limited to new buildings only. The European Union (EU), for example, has recently required that all buildings be rated for energy efficiency over the next several years. However, the EU has yet to implement a standardised test protocol with which such ratings could be performed. These ratings would apply to all buildings, both existing and new.

#### » *Minimum energy performance standards*

Minimum energy performance standards (MEPS) are also simply referred to as “standards” or “efficiency standards” in some countries. MEPS are specified minimum energy efficiency levels that products must meet before they can be legally sold in any country. In this case, specific energy standards are set before products are allowed into a country and sold. MEPS

are mandatory standards and are defined in a manner that balances technical possibility with economic viability and the competitive forces within a particular market.

» **Energy Star label**

As mentioned in the previous section, products with an Energy Star label use less energy. To earn the Energy Star, they must meet strict energy efficiency criteria. Energy Star is a US programme for office equipment, appliances, commercial food service products, home electronics, home envelope products, lighting, residential heating, cooling and ventilation equipment, new homes and other products. It is widely used and accepted across the commercial sector.



Figure 5.5: Energy Star label

Energy Star models have the following benefits:

- Computers – use 70% less electricity than computers without enabled power management;
- Monitors – use up to 60% less electricity than standard models;
- Printers – use at least 60% less electricity and must automatically enter a lower power setting after a period of inactivity;
- Fax machines – use almost 40% less electricity and may have the capability to scan double-sided pages, reducing both copying and paper costs;
- Refrigerators – at least 15% more efficient than standard models;
- TVs – consume 3 watts or less when switched off, compared to a standard TV, which consumes almost 6 watts on average;
- Light bulbs (CFLs) – use two-thirds less energy than a standard incandescent bulb and must meet additional operating and reliability guidelines;
- Furnaces – 15% more efficient than the standard.

Additional labels: Energy labels used in Indonesia, India, Malaysia, Singapore & Thailand



Figure 5.6: Energy rating labels from other countries (left to right): Indonesia, India, Malaysia, Singapore

» **Energy Benchmark Pool Frankfurt in commercial buildings**

The Energy Agency of Frankfurt (Germany) organised the Energy Benchmark Pool for commercial buildings. Building users, owners and investors were invited to analyse and optimise the energy use of their buildings in small groups of up to 10 participants and publish the results anonymously. The aim of the initiative was to enforce competition among energy-efficient buildings in Frankfurt and to give owners and investors clear figures to describe en-

ergy efficiency for their planners. The benchmark process with the owners, users or investors of a commercial building was facilitated as follows:

- Step 1: Introduction workshop (questionnaire and determination of the benchmark process);
- Step 2: Data collection by participants;
- Step 3: Data analysis by energy agency;
- Step 4: Discussion of the analysis, experience and information exchange and best practice presentation in up to three workshops;
- Step 5: Collection and public presentation of the (anonymous) results;
- Step 6: Biannual follow-up meetings to exchange experiences.

Results of the energy benchmark process:

- On average, savings potentials were identified for 25% of the total energy demand of the buildings with a payback time of less than five years.
- On average, optimising the running time of equipment with no additional investments reduced the total demand by 10 to 15%.
- The project yielded the first ever detailed analysis of the electricity demand in 10 big office buildings in Frankfurt (parts of lighting, HVAC, office equipment, etc.), showing large deviations in specific demands as well as high saving potentials.
- Implementation of the defined potential energy saving initiatives is still in progress.

A huge improvement in the energy efficiency awareness of responsible managers was one of the positive aspects of the project's implementation. The process must be made attractive to both the technical and financial departments.

#### **FURTHER READING REFERENCES AND INTERNET RESOURCES**

1. *A guide to the Nigerian power sector* • KPMG Nigeria; December, 2013
2. *Building management system* • Wikipedia;  
[https://en.wikipedia.org/wiki/Building\\_management\\_system](https://en.wikipedia.org/wiki/Building_management_system) - accessed July, 2016
3. *Buildings* • Energy Commission; <https://ec.europa.eu/energy/en/topics/energy-efficiency/buildings>
4. *Diesel engine* • Wikipedia; [https://en.wikipedia.org/wiki/Diesel\\_engine](https://en.wikipedia.org/wiki/Diesel_engine) - accessed July, 2016
5. *Diesel generator* • [https://en.wikipedia.org/wiki/Diesel\\_generator](https://en.wikipedia.org/wiki/Diesel_generator) - accessed June,2016
6. *Electric meter testing* •  
[www.gov.uk/government/uploads/system/uploads/attachment\\_data/file/285048/electricity-meter-accuracy-and-billing-disputes-flow-chart.jpg](http://www.gov.uk/government/uploads/system/uploads/attachment_data/file/285048/electricity-meter-accuracy-and-billing-disputes-flow-chart.jpg)
7. *Electrical uses* • <http://naturalgas.org/overview/uses-electrical/> - accessed June, 2016
8. *Electricity generation* • [https://en.wikipedia.org/wiki/Electricity\\_generation](https://en.wikipedia.org/wiki/Electricity_generation) - accessed June,2016
9. *Energy efficiency in buildings, Module 19* • Sustainable Energy Regulation and Policy-making for Africa; April 2007

10. *Energy efficiency in SME – ENGINE* • Target GmbH (Ed.) / EU programme intelligent energy Europe; Hannover, 2009
11. *Energy efficiency indicators: Fundamentals on statistics* • International Energy Agency (IEA); Paris, 2014
12. *How do solar cells work?* • [www.physics.org/article-questions.asp?id=51](http://www.physics.org/article-questions.asp?id=51) – accessed July, 2016
13. *Industrial diesel engine types and applications* • Diesel service and supply; [www.dieselserviceandsupply.com/industrial\\_industry\\_usage.aspx](http://www.dieselserviceandsupply.com/industrial_industry_usage.aspx) - accessed July, 2016
14. *Industrial Energy Manager – Training handbook* • Nigerian Energy Support Programme (NESP), Lagos; November, 2015
15. *Introducing energy efficiency standards and labels for appliances and equipment* • Energy Charter Secretariat - policies that work; Brussels, 2009
16. *Mitigating greenhouse gas emissions in Southern African industry* • Capacity building, leadership, and action (CBLA) Project: Industrial Energy Auditor Training Guidebook, 2014
17. *Nigeria's electricity regulator creates consumer rights network* • ESI Africa; <http://www.esi-africa.com/news/nigerias-electricity-regulator-creates-consumer-rights-network/> - April, 2015
18. *Promoting energy efficiency in residential and public sectors in Nigeria – project training manual* • GEF UNDP energy efficiency programme – Energy Commission of Nigeria; August 2011
19. *The Nigerian energy sector. An Overview with a Special Emphasis on Renewable Energy, Energy Efficiency and Rural Electrification* • GIZ-NESP, 2015  
[www.giz.de/en/downloads/giz2015-en-nigerian-energy-sector.pdf](http://www.giz.de/en/downloads/giz2015-en-nigerian-energy-sector.pdf) – accessed April, 29, 2017
20. *Trade policy review* • [www.wto.org/english/tratop\\_e/tpr\\_e/s247\\_sum\\_e.pdf](http://www.wto.org/english/tratop_e/tpr_e/s247_sum_e.pdf)
21. Working group consumers as energy market actors • Working group interim draft report  
[www.eesc.europa.eu/resources/docs/draft\\_wg\\_report\\_consumers\\_market\\_agents\\_tc\\_110315\\_web\\_version3.pdf](http://www.eesc.europa.eu/resources/docs/draft_wg_report_consumers_market_agents_tc_110315_web_version3.pdf)



## 6. ANNEXES

### ANNEX 1: KEYWORDS, SUMMARY AND DEFINITIONS

#### Energy policy

Determine energy policy objectives with those responsible (Top Management)

- Cover all aspects of energy implementation
- Define areas affected
- Determine which parties are responsible
- Commit to continuous improvement
- Specify resources needed to achieve objectives
- Supply adequate information.

#### Planning

Investigation and testing of existing energy implementation

- Analysis of energy usage
- Estimation of expected energy usage
- Identification of areas for potential improvement
- Identification of all persons and their activities, which affect total energy usage
- Accounting for compliance with legal requirements
- Determination of responsibilities
- Development of measurable, documented and (within a time frame) achievable goals.

#### Implementation and operation

Top Management: availability of necessary resources (personnel, technical and financial capital, know-how)

- Personnel: provided with adequate knowledge (energy policies, requirements of the EnMS, influence of their work on total energy usage, etc.) → Provision of training
- Internal and external communication
- Documentation describing the organisation's EnMS
- Communicate work flows and plans of action that guarantee compliance with the firm's energy policy.

#### Checking and corrective action

The organisation shall ensure that:

- The key characteristics of its operations that determine energy performance are monitored, measured and analysed
- The equipment used in monitoring and measuring of key characteristics provides data which is accurate and repeatable Key characteristics shall include at a minimum:
- The energy profile
- Significant energy uses and
- Effectiveness of the action plans in achieving objectives and targets.

#### Monitoring and measurement

Evaluation and description of the requirements of the organisation's energy programme

- Periodic measurement, oversight and recording of central energy uses, as well as the factors affecting them.



**Corrective and preventive actions**

- Detect and investigate nonconformities
- Resolve them in a suitable manner within a defined time frame
- Initiate corrective and preventive actions appropriate to the magnitude of the actual or potential problems and the energy consequences encountered
- Reviewing the effectiveness of the action taken.

**Internal Audit**

Examples of subjects for consideration by internal auditing include:

- Proper implementation of energy management programmes, processes and systems
- Opportunities for continual improvement
- Capability of processes and systems
- Use of information technology
- Performed by employees and/or by external parties appointed by the organisation
- The person or persons performing the audits are qualified, experienced, objective, impartial and independent of the area of the organisation to be audited.

**Management review**

The top Management shall review the EnMS at predetermined intervals

- The management review is to be documented and presented with the following as input parameters:
  - Follow-up actions from previous management reviews
  - Review of the energy policy
  - Review of energy performance
  - The extent to which the energy objectives and targets have been met
  - Evaluation of its conformity with legal requirements and changes within
  - Status of corrective and preventive actions
  - Energy management system audit results
  - Forecast of energy related performance
  - Recommendations for improvements.

**Results of management review**

- Changes in energy-related performance of the organisation
- Changes in energy policy
- Changes in EnPIs
- Changes in strategic and operational objectives and other elements of EnMS in accordance with the commitment of the organisation to continual improvement
- Changes providing resources.

**Motivation and communication (contents)**

Energy management systems lead to:

- Reduced costs
- Reduced energy consumption
- Increase of productivity
- Reduced emissions
- Environmental protection

- Increase of competitiveness
- Improvement of the external representation of the company and communication.

Improved communication between different departments of the company leads to:

- More efficient workflow
- Awareness of all, which department needs specific amount of energy
- Implementation of measurements can be validated with all affected people.

## ANNEX 2: ISO 50001 CHAPTERS, OVERVIEW, GLOSSARY

### Commitment

Chapter 1 — Energy management describes how your organization can develop a systematic continuous improvement method rather than have an ad hoc approach to energy management.

Chapter 2 — Scope and boundaries helps you to define which energy sources and uses are included, and which parts of the organization are included.

Chapter 3 — Energy policy helps you to develop and periodically review the energy policy document, stating your organization's commitment to achieving energy performance improvement as defined and signed off by top management.

Chapter 4 — Resources helps you to ensure that relevant personnel understand their roles, responsibility and authority, and are resourced and supported in their roles in the implementation of the energy management system. It also considers other resources such as financial and data requirements.

### Planning

Chapter 5 — Planning helps you to develop plans to reduce energy consumption.

Chapter 6 — Legal and other requirements helps you to identify and document all the legal and other requirements affecting your organization's energy use, consumption and efficiency.

Chapter 7 — Energy review takes you through all the steps that are necessary when carrying out an energy review.

Chapter 8 — Performance measurement covers energy consumption, relevant variables, energy performance indicators and baselines.

Chapter 9 — Target setting and action plans, based on available energy-saving opportunities, helps you to develop targets and action plans. Implementation

Chapter 10 — Awareness, training and competence enables you to help people that affect the energy consumption of the organization to understand their roles and to be competent in their use of energy.

Chapter 11 — Communication helps you to ensure that relevant people are aware of the Energy Management system activities and have an opportunity to contribute to the improvement of energy performance.

Chapter 12 — Documentation helps you to ensure that critical documents and records pertaining to energy performance and the energy management system are maintained and available to those requiring them.

Chapter 13 — Operational control helps you to ensure that all significant energy-using equipment and systems are maintained and are operated efficiently.

Chapter 14 — Energy-efficient design helps you to ensure that new projects or changes with a potentially significant energy impact are evaluated from an energy perspective.

Chapter 15 — Procurement helps you to ensure that the procurement of energy, equipment and services is managed to reduce costs and improve performance.

### Checking

Chapters 16 — Monitoring, measurement and analysis helps you check energy performance indicators, operating parameters and other performance-related data and information.

Chapter 17 — Evaluation of compliance with legal requirements and other requirements helps you appraise your fulfilment of the legal requirements you identified in Chapter 6.

Chapter 18 — Internal audit helps you check if the system you have set in place is working

Chapter 19 — Nonconformities provides different approaches to manage nonconformities.

Chapter 20 — Management review and continual improvement helps you monitor, audit, and check the people are using the system as intended.

Chapter 21 — Demonstrating conformity focuses primarily on the third-party certification process carried out by an independent and competent body and provides guidance on the steps involved.

Chapter 22 — Integration with other management systems looks at the benefits and factors to take into account when using more than one management system.

## ANNEX 3: EPA PORTFOLIO MANAGER



## "How To" Series

## Portfolio Manager® Quick Start Guide

EPA's ENERGY STAR Portfolio Manager tool helps you measure and track the energy and water use, waste and materials, and greenhouse gas emissions of your buildings, all in a secure online environment. You can use the results to identify under-performing buildings, set investment priorities, verify efficiency improvements, and receive EPA recognition for superior energy performance. Follow the steps in this guide to get started using the new Portfolio Manager to benchmark your properties, assess performance, and view results.

## Getting Started

- Step 1: Add a Property
- Step 2: Enter Energy & Water Data
- Step 3: View Results & Progress

## 1 Add a Property

To get started, log in to Portfolio Manager at [www.energystar.gov/portfoliomanager](http://www.energystar.gov/portfoliomanager). Then, follow these instructions to create a property and to enter property information.

1. Click **Add a Property** on the **MyPortfolio** tab.
2. Answer questions about your property and click **Get Started!**
3. Enter basic property information and select the boxes next to the statements that apply to your property. Then click **Continue**.
4. Enter Use Details such as Gross Floor Area (GFA), operating hours, and number of workers for each type of use. You can use default or temporary values at this time and enter more accurate data later. **NOTE:** Mouse over the Use Detail to see a definition.
5. Click **Add Property**. When you have successfully added your property, you will see the property's **Summary** tab.

## Property Types

All property types can be benchmarked. For properties with multiple buildings only hospitals, hotels, K-12 schools, multifamily, and senior care communities are eligible to receive the 1 – 100 ENERGY STAR score.

If you have additional types of uses on the property, you can add them at any time.

1. Click the property's **Details** tab, and then select a **Property Use Type** from the **Add Another Type of Use** drop-down menu. Click **Add**.
2. Enter Use Details for the property and then click **Save Use**.

Figure 6.1: Energy Star Portfolio Manager — quick start guide

### How to proceed using the Energy Star Portfolio Manager:

- Determine the energy team. This can include the building engineer, facility manager, head of production line manager and commissioning agent.
- Gather at least 12 months (36 months, if possible) of monthly energy data from utility bills (e.g. electricity, natural gas, etc.). This data should be readily available from the utility.
  1. Note whether the facility sub-meters specific energy systems.
  2. For additional guidance, visit [www.energystar.gov/index.cfm?c=assess\\_performance.gather\\_data](http://www.energystar.gov/index.cfm?c=assess_performance.gather_data)
- Analyse monthly utility bills to identify overall trends, seasonal fluctuations, and unexplained changes in energy use.

1. An easy way to analyse trends and discover unexplained changes in utility consumption is to use a spreadsheet to track a rolling 12-month average of monthly utility consumption and demand. This method helps screen out seasonal variation and identify underlying energy consumption or demand increases.
  2. Conversion to units per square foot will help to recognize disparities caused by changes in a building's square footage. Use the ENERGY STAR methodology for calculating square footage to ensure that data entered in the system is comparable, a necessity for achieving accurate benchmark rating comparisons.
- Create an account with EPA ENERGY STAR Portfolio Manager. For help getting started, use the following resources:
    1. Portfolio Manager Overview
    2. Portfolio Manager "Starter Kit"
    3. Portfolio Manager Animated Trainings
    4. Portfolio Manager Data Entry
    5. Portfolio Manager Quick Reference Guide
    6. Portfolio Manager Data Collection Worksheet
    7. How to Submit & Manage a Building Profile
  - Establish a baseline year (or average of several years).
  - Enter utility data into EPA ENERGY STAR Portfolio Manager to benchmark energy consumption with comparable facilities. To understand the data you need to gather, you can find the definitions for each field name in Portfolio Manager in this spreadsheet.
  - Note your facility's baseline ENERGY STAR score. If it is greater than 50, your facility's energy systems are currently more efficient than half the similar facilities in the United States. If the score is 75 or higher, your facility falls into the top 25 percent of energy-efficient hospitals in the United States and is eligible to receive an ENERGY STAR label. The label is valid for one year and requires third-party validation of performance. This process can be performed every year if a facility qualifies, and the program covers hospitals, laundries, garages, data centres, health care campuses, and medical office buildings. For additional information about how to apply for the ENERGY STAR label, visit [www.energystar.gov/index.cfm?c=evaluate\\_performance.bus\\_portfoliomanager\\_intro](http://www.energystar.gov/index.cfm?c=evaluate_performance.bus_portfoliomanager_intro).
  - Trend and track ENERGY STAR scores and energy use over time to demonstrate improvements.
  - Use the Roadmap's target-setting Energy Reduction Tool to help set goals based on your baseline and benchmark data.
  - Consider the use of sub-metering and circuit-level metering to identify and track specific end users and reductions.



**ANNEX 4: SUMMARY OF AUDIT STEPS AND THEIR CONTENTS<sup>13</sup>**

<b>Steps</b>	<b>Contents</b>
Conduct a condition survey	Identifies the most likely locations for the audit Identifies EMOs that could be implemented without further analysis Helps to set priorities for the audit's mandate and scope
Establish the audit mandate	Establishes and articulates the purpose of the audit. Secures stakeholder input and commitment to the audit mandate
Establish the Audit Scope	Specifies the physical extent of the audit by setting the terms of the boundary around the audited energy consuming system. Identifies energy inputs that cross the boundary to be audited
Analyse energy consumption and costs	Tabulates all energy inputs - purchased and otherwise. Establishes the annual pattern of energy consumption and total annual consumption.
Comparative analysis	Compares current energy performance with internal historical performance and external benchmarks. Provides insight into what drives the energy consumption of a facility and what relative savings potential may exist
Profile energy use patterns	Develops an understanding of the time patterns in which the system consumes energy
Inventory energy use	Provides a clear picture of where energy is being used. Helps to prioritize possible EMOs and reveal opportunities for reduction by eliminating unnecessary uses'
Identify Energy Management Opportunities (EMOs)	Involves critical assessment of systems and levels of energy consumption. Methods range from open-ended analyses to close-ended checklists Helps to determine whether a more detailed micro audit is needed

<sup>13</sup> Energy savings toolbox – An energy audit manual and tool – Natural Resources Canada, 2011. Reproduced with the permission of the Department of Natural Resources, 2016

**ANNEX 5: CHECK LIST FOR A SURVEY OF BUILDINGS AND OFFICES****1. Basic Information required data**

<b>Basic information</b>	<b>Comment</b>
Date of energy audit:	
Department/Building/Area covered:	
Persons conducting audit:	
Normal occupancy hours of building:	
Cleaning times:	

**2. Lighting**

<b>Questions</b>	<b>Comments</b>
Are any tungsten lights present? Can they be replaced with energy saving bulbs? Look particularly in store rooms, uplighters, desk lamps etc.	
If there are several light switches, can they be labelled to make it more obvious which switches relate to which appliances?	
Can lights be switched off to make use of daylight? (e.g. lights parallel to windows or in corridors)	
If space is intermittently occupied (e.g. store rooms, toilets, kitchen areas, copying rooms, corridors) is there scope for automatic lighting controls?	
Are any external lights on during daylight hours?	
Can main lighting ever be switched off and use made of desk lamps?	
Do any light fittings need cleaning?	
Do windows and skylights need cleaning to allow in more natural light?	

**3. Cooling and Ventilation**

<b>Questions</b>	<b>Comments</b>
If there is air conditioning with local controls, make sure it is only on when necessary. Is it obvious how to control it? What temperature is it set to?	
Could the building reduce heat by closing blinds or fitting reflective film to windows which reduce solar gain? Remember, unnecessary lights and electrical equipment also produces heat.	
Are all external doors and windows closed when air conditioning is on?	
Are you making the most of natural ventilation? Opening windows overnight in the summer, where it doesn't present a security risk, will help cool the building down and reduce the need for air conditioning.	
Is air conditioning on in unused spaces, such as cupboards, corridors?	

**4. Electrical equipment**

<b>Questions</b>	<b>Comments</b>
Are computers, printers, photocopiers and other equipment switched off at the end of the day?	
Can screens and other equipment be switched off during the day?	
Can standby settings be avoided? (E.g. TVs, LCD projectors, printers etc.)	

<b>Questions</b>	<b>Comments</b>
Are photocopiers, fax machines and other equipment on 'Energy Saver' mode during the day?	
Are photocopiers in a well ventilated area – not where there is air conditioning?	
Can a 7 day timer be put on some equipment? (E.g. photocopiers, water coolers, cold drinks machines).	
Can any equipment be switched on later and switched off earlier?	
Could timers be fitted to water coolers?	
Are kettles overfilled for hot drinks?	
Can kettles be removed if there is a wall mounted boiler?	
Are fridges placed next to heat sources? They run more efficiently when in a cool environment.	
Is the office fridge/freezer defrosted regularly?	
Is the fridge thermostat working and set to the right temperature (2-4°C)?	
Are microwaves switched off at the plug after use?	
Is equipment clearly labelled so that staffs know how to activate energy saving features or switch it off?	

#### 5. Water use

<b>Questions</b>	<b>Comments</b>
Is there any evidence of water leaks? (e.g. wet pathways on a dry day)	
Are taps left running? Are there any dripping taps? Do taps need maintenance?	
Is there scope for push button taps?	
Are hot water heater timers set correctly?	
If there is no timer should one be fitted?	
Is water escaping from overflows either inside or outside buildings?	

#### 6. Awareness<sup>14</sup>

<b>Questions</b>	<b>Comments</b>
Are there posters/stickers/guidance displayed to remind people of good practice?	
Would it be of benefit to have a formal energy audit with a member of the estates team?	

<sup>14</sup> Green Impact Universities. Energy audit checklist, [www2.le.ac.uk](http://www2.le.ac.uk) – accessed April 12, 2017

## ANNEX 6: SAMPLE CONTRACTS FOR CONTRACTING AN AUDITOR

### SAMPLE 1

#### ENERGY AUDIT AGREEMENT MODEL ENERGY AUDIT AGREEMENT (DRAFT COPY)

This Energy Audit Agreement is entered into on \_\_\_\_\_, 201\_, by and between \_\_\_\_\_ (the "Institution") and \_\_\_\_\_ (the "Company").

The Institution and the Company are referred to herein as the "Parties". Whereas, the Institution has issued a Request For Proposals (RFP) to identify a Qualified Provider for a guaranteed energy savings contract. Whereas, the Company submitted a response to the RFP and participated in a competitive evaluation procedure designed to identify a Qualified Provider. Whereas, the Institution has selected the Company as a Qualified Provider;

Whereas, the Institution is responsible for the operation, management and maintenance of \_\_\_\_\_ (the "Facility").

Whereas, a comprehensive energy use and savings analysis (the "Energy Audit") must be performed at the Facility in order to determine the feasibility of entering into an Energy Performance Contracting Project to provide for the installation and implementation of energy conservation measures (ECMs) at the Facility.

Whereas, if the ECMs are demonstrated to be feasible, and if the amount of energy savings can be reasonably ascertained and guaranteed in an amount sufficient to cover all costs associated with an energy performance contracting project at the Facility, the Parties intend to negotiate an Energy Services Agreement (ESA) under which the Company shall design, procure, implement, provide training, maintain and monitor such energy conservation measures at the Facility.

Therefore, the Parties agree as follows:

#### ARTICLE 1: SCOPE OF ENERGY AUDIT

The Company will perform the Energy Audit and prepare a detailed engineering and economic report (the "Report"), which specifically identifies the energy improvements and operational changes which are recommended to be installed or implemented at the Facility. The Report shall contain detailed projections of energy and cost savings to be obtained at the Facility as a result of the installation of the recommended energy conservation measures (ECMs). The savings calculations must utilize assumptions, projections and baselines which best represent the true value of future energy or operational savings for the Facility, including accurate marginal cost for each unit of savings at the time the audit is performed; documented material and labour costs actually avoided, adjustments to the baseline to reflect current conditions at the Facility, compared to the historic base period, calculations which account for the interactive effects of the recommended ECMs, etc.

The Report shall clearly describe how utility tariffs were used to calculate savings for all ECMs. The Report shall describe the Company's plan for installing or implementing the measures in the Facility, including all anticipated costs associated with such installation and implementation. The primary purpose of the Report is to provide an engineering and economic basis for negotiating an ESA between the Institution and the Company,; however, the Institution shall be under no obligation to negotiate such a contract. The Company shall perform the following tasks in performing the Energy Audit and preparing the Report:

#### Collect General Facility Information

1. The Company shall collect general Facility information such as:

Size, age, construction type, condition and general use of the Facility.

The Company shall also collect and summarize Facility utility cost and consumption data for the most recent 36-month period.

Company shall evaluate the impact on utility cost and consumption for any energy measures currently being installed or currently contemplated to be installed by the Institution in the Facility which will remain separate from the Energy Services Agreement throughout the duration of the ESA.

Institution shall furnish (or cause its energy suppliers to furnish) all available records and data concerning energy and water usage for the Facility for the most current 36 month period, if available, including:

Utility records, occupancy information, descriptions of any changes in the structure of the Facility or its heating, cooling, lighting or other systems or energy requirements, descriptions of all major energy and water consuming or energy and water saving equipment used in the Facility, and description of energy management procedures presently utilized.

The Facility shall also furnish a record of any energy related improvements or modifications that have been installed during the past three years, or are currently being installed or are currently contemplated to be installed by the Institution in the Facility separate from the Energy Service Agreement throughout the duration of that agreement.

The Institution shall also provide copies of drawings, equipment logs and maintenance work orders to the Company insofar as this information is readily available.

## 2. Inventory Existing Systems and Equipment

Company shall compile an inventory based on a physical inspection of the major electrical and mechanical systems at the Facility, including:

- Cooling systems and related equipment
- Heating and heat distribution systems
- Automatic temperature control systems and equipment
- Air distribution systems and equipment
- Outdoor ventilation systems and equipment
- Kitchen and associated dining room equipment, if applicable
- Exhaust systems and equipment
  - Hot water systems
  - Electric motors 5 HP and above, transmission and drive systems
  - Interior and exterior lighting
  - Laundry equipment, if applicable
  - Water consumption end uses, such as restroom fixtures, water fountains, irrigation, etc.
  - Other major energy using systems, if applicable

The inventory shall address the following considerations:

- a. The loads, proper sizing, efficiencies or hours of operation for each system; (Where measurement costs, facility operating or climatic conditions necessitate, engineering estimates may be used, but for large fluctuating loads with high potential savings, appropriate measurements are required unless waived by the Institution).
- b. Current operating condition for each system;
- c. Remaining useful life of each system;
- d. Feasible replacement systems;
- e. Hazardous materials and other environmental concerns.

The Company shall use data loggers and conduct interviews with Facility operation and maintenance staff regarding the Facility's systems operation, occupancy patterns and problems with comfort levels or equipment reliability.

## 3. Establish Base Year Consumption and Reconcile with End Use Consumption Estimates. Company shall examine the most recent 36 months of utility bills and establish Base Year consumption for

electricity, fossil fuels and water by averaging, or selecting the most representative contiguous 12 months.

4. Company shall consult with Facility staff and account for any unusual or anomalous utility bills which may skew Base Year consumption from a reasonable representation.
5. Company shall estimate loading, usage and/or hours of operation for all major end uses representing more than 5% in aggregate of total Facility consumption including, but not limited to:
  - Water
  - Lighting
  - Heating
  - Cooling
  - HVAC motors (fans and pumps)
  - Plug load
  - Kitchen equipment
  - Other equipment
  - Miscellaneous

Where loading and/or usage are highly uncertain Company shall employ spot measurement and/or short term monitoring at its discretion, or at the request of the Institution.

Reasonable applications of measurement typically include variable loads that are likely candidates for conservation measures, such as cooling equipment. The annual end use estimated consumption shall be reconciled with the annual Base Year consumption to within 5% for electricity (kWh), fossil fuels and water. The contribution to electric peak demand for each end use shall also be reconciled to within 5% of the annual Base Year peak. The “miscellaneous” category shall not be more than 5%. The purpose of this is to place reasonable limits on potential savings.

6. Develop List Of Potential Energy Conservation Measures (ECMs)
  - i. Identify and propose potential ECMs for installation or implementation at the facility, including water conservation measures, ECMs that the Institution is particularly interested in are specified in Attachment A, and should be addressed in the Report. The attached list is not intended to be exhaustive nor limit the Company's evaluation and development of a comprehensive list of potential ECMs.
  - ii. Estimate the cost, savings and life expectancy of each proposed ECM.
  - iii. Specify Facility operations and maintenance procedures which will be affected by the installation/implementation of the proposed ECMs.
  - iv. Provide analysis methodology, supporting calculations and assumptions used to estimate savings. Manual calculations should disclose essential data, assumptions, formulas, etc. so that a reviewer could replicate the calculations based on the data provided.
  - v. For savings estimates using computer simulations, Company shall provide access to the program and all inputs and assumptions used, if requested by the Institution.
  - vi. Provide a preliminary savings measurement and verification plan for each proposed ECM.
  - vii. Provide a preliminary commissioning plan for the proposed ECMs.
  - viii. Provide detailed calculations for any rate savings proposals.
  - ix. Provide detailed supporting calculations for any proposed maintenance savings.
  - x. Estimate any environmental costs or benefits of the proposed ECMs (e.g. disposal costs, avoided emissions, water conservation, etc.). This list shall be compiled and submitted to the Institution within \_\_\_ days (120 days is recommended) of the execution of this Project Development Agreement.

7. Select Final Recommended ECMs Company shall, in consultation with the Institution, recommend specific ECMs from its preliminary compilation for installation and implementation at the Facility. 6. Cost and Fee Estimates Company shall provide detailed estimates of costs associated with the installation, implementation and commissioning of each of the ECMs proposed in the Audit including breakouts for labour, materials, and equipment.

In addition, project cost data must be provided in the format included in Attachment B: AUDITING COMPANY XXX, Cost Proposal and Cash Flow Analysis. Company shall also provide estimates of monthly costs associated with sustaining the project performance including breakouts for maintenance fees, monitoring fees, and training fees.

#### 8. Savings Estimates

The Institution has endeavoured to provide the Company with sufficient general and specific guidance in this Article 1 to develop the savings estimates for the Report. In the event that questions arise as to the calculation of savings or whether certain items will be allowed as savings, the Company should seek written guidance from the Institution. The Institution reserves the right to reject items claimed as savings, which are not in the Institution's utility budget line, or which have been claimed contrary to the guidance given in this agreement or contrary to written guidance given to Company.

The Institution also reserves the right to reject Company calculations of savings when it determines that there is another more suitable or preferable means of determining or calculating such savings. For the purposes of completing the Cash Flow Analysis in Attachment B, the following items will be allowed as savings or in the development of savings:

Escalation rates of \_\_\_\_\_% for natural gas Escalation rates of \_\_\_\_\_% for electricity Escalation rates of \_\_\_\_\_% for oil Escalation rates of \_\_\_\_\_% for steam Escalation rates of \_\_\_\_\_% for water Escalation rates of \_\_\_\_\_% for other fuel type (specify) Escalation rates of \_\_\_\_\_% for operation and maintenance cost savings Escalation rates of \_\_\_\_\_% for material/commodity cost savings Escalation rates of \_\_\_\_\_% for allowable labour savings.

The following items will not typically be credited as savings derived from a proposed ECM. The Company may seek exemptions from the Institution on a case-by-case basis. However, the final determination of allowable savings in each case considered shall reside with the Institution:

- Institution in-house labour cost
- Institution deferred maintenance cost
- Offset of future Institution capital cost

#### 9. Report Format

The Report shall, at a minimum, include the following:

- a. An executive summary which describes the facility, measures evaluated, analysis methodology, results and a summary table presenting the cost and savings estimates for each measure and for the project as a whole.
- b. A discussion of measures not evaluated in detail and the explanation of why a detailed analysis was not performed.
- c. A summary of all utility bills, Base Year consumption and how it was established, and end use reconciliation with respect to the Base Year including a discussion of any unusual characteristics and findings.
- d. Detailed descriptions for each ECM including analysis method, supporting calculations (may be submitted in appendices), results, proposed equipment and implementation issues.
- e. A discussion of the conclusions, observations and caveats regarding cost and savings estimates.
- f. Thorough appendices, which document the data, relied upon to prepare the analysis and how that data was collected. It should be noted that the base rate value for each fuel and water unit will not devalue in the event of any rate decrease. The Institution reserves the right to impose ceiling rates for fuel escalations. The Report shall be completed within



\_\_\_\_\_ days (120 days is recommended) of the date of execution of this Energy Audit Agreement. The cost for the completed Energy Audit and Report will be \_\_\_\_\_.

#### ARTICLE 2: ENERGY SERVICES AGREEMENT (ESA)

The Parties intend to negotiate an ESA under which the Company shall design, install and implement energy conservation measures which the Parties have agreed to and provide certain training, maintenance and monitoring services. However, nothing in this Agreement should be construed as an obligation on any of the Parties to execute such an ESA. The terms and provisions of such an ESA shall be set forth in a separate agreement.

#### ARTICLE 3: PAYMENT

Payment to Company for services performed in connection with the Energy Audit Agreement shall be made by Institution only in accordance with the provisions of Article 4 herein.

#### ARTICLE 4: TERMINATION

1. By Contractor: Company may terminate this Agreement prior to the completion of the Energy Audit and Report or subsequent to the scheduled completion of the Energy Audit and Report if:
  - i. It determines that it cannot guarantee a minimum \_\_\_% savings in energy costs through the implementation of an energy performance contracting project at the Facility; or
  - ii. It determines that even though it can guarantee a \_\_\_% savings in energy costs, that amount would be insufficient to cover the costs associated with performing the Audit, installing energy conservation measures and related training, maintenance and monitoring services. In the event Company terminates the Agreement pursuant to Section 4 A (i) or (ii) the Institution shall not be obligated to pay any amount to Company for services performed or expenses incurred by Company in performing the Energy Audit and Report required under this Agreement.

Company shall provide the Facility with any Audit documents (preliminary notes, reports or analysis), which have been produced or prepared prior to the effective date of the termination. Company will return any documents or information that was provided by the Institution. Termination under this section shall be effective upon Institution's receipt of written notification from the Company stating the reason for the termination and all documents which support termination pursuant to 4 A (i) or 4 A (ii) herein.

2. By Institution:

Institution may terminate this Agreement:

- i. If the Company fails to complete the Energy Audit and deliver the Report to the Institution by the date established in Article 1 H. above; or fails to obtain a written extension of that date from the Institution. Termination under this subsection B (i) shall be effective upon Company's receipt of written notification from the Institution that the deadline for submission of the Energy Audit and Report has past. In this event, the Institution shall not be obligated to pay any amount to Company for services performed or expenses incurred by the Company in performing the Energy Audit and preparing the Report required under this Agreement. Company shall provide the Facility with any Audit documents (preliminary notes, reports or analysis), which have been produced or prepared prior to the effective date of the termination. Company will return any documents or information that was provided by the Institution.
- ii. If, prior or subsequent to the completion of the Energy Audit or Report, the Company notifies the Institution in writing that it is unable to guarantee a sufficient level of savings pursuant to subsection 4 A (i) or (ii) above. Termination under this subsection B (ii) shall be effective upon Company's receipt of written notification of termination from the Institution. In this event, the Institution shall not be obligated to pay any amount to Company for services performed or expenses incurred by Company in performing the Energy Audit and preparation of the Report required under this Agreement. Company shall provide the Facility with any Audit documents (preliminary notes, reports or analysis), which have been produced or prepared prior to the effective date of the termination. Company will return any documents or information that was provided by the Institution.
- iii. If, prior or subsequent to the completion of the Energy Audit or Report, the Institution notifies the Company in writing that it has elected to terminate this Agreement and not enter into an

ESA, the Institution shall reimburse the Company for either the actual expenses incurred or percent of the Audit and Report completed as of the effective date of the termination, the amount being determined as fair and equitable by the Institution. Termination under this subsection B (iii) shall be effective upon Company's receipt of written notification from the Institution.

Company agrees to provide the Institution with any records of expenses incurred and any preliminary notes, reports or analyses which have been produced or prepared prior to the effective date of the termination. Such documentation shall be used by the Institution to determine the extent of work completed by Company prior to termination and shall become the property of the Institution. If after completion and acceptance of the Energy Audit, the Institution does not enter into an ESA with the Company within \_\_\_\_\_ days (60 days is recommended) after written acceptance of the Energy Audit, the Institution agrees to reimburse the Company for the cost of the Energy Audit as detailed herein. Termination under this subsection B (iii) shall be effective upon Company's receipt of written notification from the Institution. The Energy Audit and Report will become the property of the Institution. It is clearly understood by both parties hereto that, if the Parties successfully negotiate and execute an Energy Services Agreement, no payment shall be due for the Energy Audit or Report under the terms of this Agreement. This Agreement shall automatically terminate upon the execution of an ESA by Company and the Institution for an energy performance contracting project at the Facility.

It is further understood that provisions for payment for the Energy Audit shall be incorporated into the ESA.

#### ARTICLE 5: STANDARD TERMS AND CONDITIONS SECTION

##### 1. SECTION 1 Agreement Term

The Agreement term shall commence on the date the Agreement is executed by the Institution and end on \_\_\_\_\_, unless earlier terminated pursuant to the provisions of Article 4 hereof. Notwithstanding, Company shall adhere to the deadlines set forth in Article 1 regarding the completion and submittal of the list of ECMs and the Report.

##### SECTION 2. Materials, Equipment and Supplies

The Company shall provide or cause to be provided all facilities, materials, equipment and supplies necessary to perform the Energy Audit and prepare the Report.

##### SECTION 3. Patent and Copyright Responsibility

The Company agrees that any material or design specified by the Company or supplied by the Company pursuant to this Agreement shall not knowingly infringe any patent or copyright, and the Company shall be solely responsible for securing any necessary licenses required for patented or copyrighted material utilized by the Company in the performance of the Energy Audit and preparation of the Report.

##### SECTION 4. Institution Access to Records

The Institution shall have the right, throughout the term of this Agreement and for a minimum of \_\_\_\_\_ years following completion of the Agreement, to inspect, audit and obtain copies of all books, records and supporting documents which Company is required to maintain according to the terms of this Agreement.

##### SECTION 5. Personnel

All personnel necessary for the effective performance of the Energy Audit shall be employed by Company and its designated subcontractors, shall be qualified to perform the services required under this Agreement, and shall in all respects be subject to the rules and regulations of Company governing staff members and employees. Neither Company, its designated subcontractors nor its personnel shall be considered to be agents or employees of the Institution.

##### SECTION 6. Compliance with Applicable Law

In performance of its obligations pursuant to this Agreement, Company shall comply with all applicable provisions of federal, state and local law. All limits or standards set forth in this Agreement to be observed in the performance required under this Agreement are minimum requirements, and shall not affect the application of more restrictive federal, state or local standards applied to the performance of the Agreement.

## SECTION 7. Waivers

No right of either party hereto shall be deemed to have been waived by non-exercise thereof, or otherwise, unless such waiver is reduced to writing and executed by the party entitled to exercise such right.

## SECTION 8. Assignment

This Agreement may not be assigned by the Company without the prior written consent of the Institution.

## SECTION 9. Federal Taxpayer Identification Number and Legal Status Disclosure

Under penalty of perjury, the Company certifies that \_\_\_-\_\_\_\_ is the Company's correct Federal Taxpayer Identification Number and that the Company is doing business as a Corporation.

## SECTION 10. Governing Law

This Agreement shall be governed by and construed only in accordance with the laws of the Federal Republic of Nigeria.

## SECTION 11. Agreement

The following documents are incorporated in, and made a part of, this Agreement:

Attachment A - Facility's Recommended ECMs (Optional) Attachment B – AUDITING COMPANY XXX cost proposal and project cash flow analysis (Note: Institution should include all required policy provisions which may include the following :)

Attachment I - drug free workplace provisions

Attachment II - equal employment opportunity clause

Attachment III - Certification of Capacity to Contract Attachment

Attachment IV- Certifications

## SECTION 12. Project Management

All necessary and ordinary communications, submittals, approvals, requests and notices related to Project work shall be issued or received by: For Institution: For Company:

## SECTION 13. Amendments

This Agreement and Attachments referenced in Section 11 herein constitute the entire Agreement between the Parties. No amendment hereof shall be effective until and unless reduced to writing and executed by the Parties.

ARTICLE 6: EXECUTION IN WITNESS WHEREOF, the parties have executed this Agreement this \_\_\_\_\_ day of \_\_\_\_\_, 201\_. INSTITUTION \_\_\_\_\_ BY: \_\_\_\_\_ TITLE: \_\_\_\_\_ COMPANY \_\_\_\_\_ BY: \_\_\_\_\_ TITLE: \_\_\_\_\_

**SAMPLE 2**

## Technical Energy Audit &amp; Project Development Agreement Sample

Technical energy audit and project development agreement with Negotiating Tips. The contract is a sample document only and does not attempt to identify or address all circumstances or conditions you may encounter or desire. Consult with your legal counsel and procurement staff to adapt this to meet your needs. This Technical energy audit & project development Agreement (the "Agreement") is made and entered into as of <Date>, between <Energy Service Company Name> (AUDITING COMPANY XXX), having its principal offices at <AUDITING COMPANY XXX Address>, and the <name of Institution> (Institution).

**WITNESSETH**

WHEREAS, AUDITING COMPANY XXX is a company with experience and technical and management capabilities to provide for the discovery, engineering, packaging, procurement, installation, financing, maintenance and monitoring of energy and water saving measures at facilities similar in size, function and system type to Institution's facilities, and WHEREAS, AUDITING COMPANY XXX has submitted a response to Institution's

Request for Proposals (RFP) pertaining to the discovery, engineering, packaging, procurement, installation, financing, maintenance and monitoring of energy and water saving measures at Institution's facilities.

WHEREAS, Institution has selected AUDITING COMPANY XXX to provide the services described herein, and WHEREAS, Institution desires to enter into an agreement to have AUDITING COMPANY XXX perform a technical energy audit and project development Proposal to determine the feasibility of entering into an Energy Performance Contract (EPC) to provide for installation and implementation of energy and water saving measures at Institution's facilities.

WHEREAS, if energy and water saving measures are determined to be feasible, and if the amount of savings can be reasonably sufficient to cover all costs, as defined by Institution, associated with an energy performance contracting project, the parties intend to negotiate an EPC under which the AUDITING COMPANY XXX will design, procure, install, implement, maintain and monitor such energy and water saving measures. However, this intent does not commit Institution to entering into such EPC.

THEREFORE, the parties agree as follows:

1. Technical Energy Audit And Project Development Agreement

AUDITING COMPANY XXX agrees to perform a technical energy audit in accordance with the Scope of Work described below. AUDITING COMPANY XXX agrees to complete the technical energy audit and present to Institution a final report within <Number of Days –about 45 to 90 days recommended depending on size and complexity of facilities> calendar days from the execution of this Agreement.

The Institution agrees to assist the AUDITING COMPANY XXX in performing the technical energy audit in accordance with the Scope of work described below. The Institution agrees to work diligently to provide full and accurate information. AUDITING COMPANY XXX agrees to work diligently to assess validity of information provided and to confirm or correct the information as needed.

AUDITING COMPANY XXX agrees to offer a Project Development Agreement with a proposal of Energy Performance Contract terms and conditions, based on a recommended package of energy and water saving measures selected by the AUDITING COMPANY XXX. The proposal will include details as specified in the Scope of Work below.

2. Compensation to AUDITING COMPANY XXX

Except as provided for below, within <Number of Days: about 45 to 60 days recommended> days after AUDITING COMPANY XXX's submission of the final Technical Audit report, The Institution shall compensate AUDITING COMPANY XXX for performance of the Audit by payment to AUDITING COMPANY XXX of <Audit Cost Amount> <Note to Customer: Expect about \$0.06 to \$0.12 per square foot depending on project complexity, size and scope of project, and geographic location.>

- a. Institution shall have no payment obligations at the time of execution of this Agreement, but acknowledges that the fee indicated above shall be incorporated into AUDITING COMPANY XXX's project costs, in the event AUDITING COMPANY XXX and Institution execute an EPC within <Number of Days – allow sufficient time for contract negotiation and signing, 60 to 75 days recommended> days, or such longer period as the parties may mutually agree, after submission of the final Technical Energy Audit report and Project Development Agreement by AUDITING COMPANY XXX to Institution.
- b. Should the AUDITING COMPANY XXX determine any time during the Technical Energy Audit that savings cannot be attained to meet Institution's terms as set forth in the RFP, the Technical Energy Audit will be terminated by written notice of the AUDITING COMPANY XXX to the Institution. In this event this Agreement shall be cancelled and Institution shall have no obligation to pay, in whole or in part, the amount specified.
- c. Institution shall have no payment obligations under this Agreement in the event that AUDITING COMPANY XXX's final Technical Energy Audit report does not contain a package of energy and water saving measures which, if implemented, will provide the Institution with guaranteed cash savings to meet the following terms:
- d. Sufficient to fund Institution's payments of all costs and fees associated with the Energy Performance Contract, including any annual fees to the AUDITING COMPANY XXX, less any cash payment the Institution may choose to contribute. Analysis will be based on AUDITING COMPANY XXX's proposed financing terms including a conventional, level payment, fully amortizing

(less a nominal final purchase option price of \$1.00) lease-purchase agreement over a fixed twenty-five (25) year maximum term with a fixed rate of interest actually available to Institution.

### 3. Scope of work

The Technical Energy Audit and Project Development Agreement shall be performed as described below:

- a. Establish allowable cost and savings factors approved for consideration by Institution. The Institution will provide AUDITING COMPANY XXX with sufficient guidance to develop savings estimates.
- 1) Savings estimates may include:
  - a) Procurement of low-cost energy supplies of all types, including electricity, natural gas and water.
  - b) Insulating the building structure or systems in the building.
  - c) Storm windows or doors, caulking or weather stripping, multiglazed windows or door systems, heat-absorbing or heat-reflective glazed and coated window and door systems, additional glazing, reductions in glass area or other window and door system modifications that reduce energy consumption.
  - d) Automated or computerized energy control systems.
  - e) Heating, ventilation or air conditioning system modifications or replacements.
  - f) Replacing or modifying lighting fixtures to increase the energy efficiency of the lighting system.
  - g) Energy recovery systems.
  - h) Cogeneration systems that produce steam or forms of energy such as heat, as well as electricity, for use primarily within a building or complex of buildings.
  - i) Installing new or modifying existing day lighting systems.
  - j) Installing or modifying renewable energy and alternate energy technologies.
  - k) Building operation programs that reduce energy costs including, but not limited to, computerized programs, training and other similar activities.
  - l) Steam traps improvement programs that reduce energy costs.
  - m) Devices that reduce water consumption, and
  - n) Any additional building infrastructure improvements that produce energy cost savings, significantly reduce energy consumption or increase the energy efficiency of the facilities for their appointed functions and are in compliance with all applicable state building codes.
- 2) Savings estimates will not include:
  - a) Institution in-house labour costs
  - b) Institution deferred maintenance cost
  - b) Offset of future customer capital cost
- 3) The following items may be negotiated:
  - a) Escalation rates for natural gas, electricity, water, material/commodity cost savings, and allowable labour savings. These are rates to be used in cash flow projections for project development purposes. Actual rates and a floor rate may be used in a subsequent performance contract.

**<Note: Check with your local utilities to ensure reasonableness. Also note that rates could vary in different years during the contract term. >**

- b) Interest rates (municipal tax-exempt rates for public institutions)
- c) Institution equity cash outlay (Institution's option)
- d) The following items may not be negotiated: <Note: Insert non-negotiable items from above list. >
  - h) The following mark-up costs are disclosed to provide Institution and the Institution

with typical project costing approach for a project of similar scope and size. These rates will be expected to be used in the Technical Energy Audit and subsequent

EPC, however, scope and size of project may change and necessitate a change in the mark-ups provided below.

**<Note: Include any additional categories your AUDITING COMPANY XXX uses in its pricing structure.>**

Cost category

% of project construction cost

Overhead _____	Profit _____	Mark-ups on subcontractors _____
_____	Mark-ups on equipment/supplies _____	Mark-ups on self-performed work _____
Design _____	Construction Management _____	_____
Commissioning _____	Monitoring and Verification _____	Other _____

<Note: It is important to negotiate these costs prior to entering this Agreement. Also, identify how mark-ups and fixed fees were determined and how they will be applied.>

b. Collect data and background information from Institution concerning facility operation and energy use for the most recent three years from the effective date of this Agreement as follows.

- 1) Building square footage.
- 2) Construction date of buildings and major additions
- 3) Utility company invoices
- 4) Occupancy and usage information
- 5) Description of all energy-consuming or energy-saving equipment used on the premises, as available.
- 6) Description of energy management procedures utilized on the premises
- 7) Description of any energy-related improvements made or currently being implemented
- 8) Description of any changes in the structure of the facility or energy-using or water using equipment
- 9) Description of future plans regarding building modifications or equipment modifications and replacements
- 10) Drawings, as available (may include mechanical, plumbing, electrical, building automation and temperature controls, structural, architectural, modifications and remodels)
- 11) Original construction submittals and factory data (specifications, pump curves, etc.), as available
- 12) Operating engineer logs, maintenance work orders, etc., as available
- 13) Records of maintenance expenditures on energy-using equipment, including service contracts 14) Prior energy audits or studies, if any

The Institution agrees to work diligently to furnish AUDITING COMPANY XXX, upon request, accurate and complete data and information as available. Where information is not available from the Institution, AUDITING COMPANY XXX will make a diligent effort to collect such information through the facility inspection, staff interviews, and utility companies.

AUDITING COMPANY XXX agrees to work diligently to assess validity of information provided and to confirm or correct the information as needed.

c. Perform a facility inspection.

- 1) Interview the facility manager, maintenance staff or others regarding:
  - a) Facility operation, including energy management procedures
  - b) Equipment maintenance problems
  - c) Comfort problems and requirements



- d) Equipment reliability,
- e) Projected equipment needs, etc.
- f) Occupancy and use schedules for the facility and specific equipment.
- g) Facility improvements, past and planned
- 2) Inspect major energy-using equipment, including:
  - a) Lighting (indoor and outdoor)
  - b) Heating and heat distribution systems
  - c) Cooling systems and related equipment
  - d) Automatic temperature control systems and equipment e) Air distribution systems and equipment
  - e) Outdoor ventilation systems and equipment
  - f) Exhaust systems and equipment
  - g) Hot water systems
  - h) Electric motors, transmission and drive systems
  - i) Special systems (kitchen/dining equipment, swimming pools, laundry equipment, etc.)
  - j) Renewable energy systems l) other energy using systems m) Water consuming systems (restroom fixtures, water fountains, irrigation systems, etc.)
- 3) Perform "late-night" surveys outside of normal business hours or on weekends to confirm building system and occupancy schedules, if deemed necessary.
- 4) Develop a preliminary list of potential energy and water saving measures. Consider the following for each system:
  - a) Comfort and maintenance problems
  - b) Energy use, loads, proper sizing, efficiencies and hours of operation
  - c) Current operating condition
  - d) Remaining useful life
  - e) Feasibility of system replacement
  - f) Hazardous materials and other environmental concerns
  - g) Institution's future plans for equipment replacement or building renovations h) Facility operation and maintenance procedures that could be affected

The Institution will allow AUDITING COMPANY XXX reasonable access to facility staff to ensure understanding of existing systems and opportunities.

AUDITING COMPANY XXX agrees to work diligently to assess validity of information provided and to confirm or correct the information as needed.

d. Establish base year consumption and reconcile with end use consumption estimates.

- 1) Examine utility bills for the past 3 years and establish base year consumption for electricity, gas, steam, water, etc. in terms of energy units (kWh, kW, ccf, Therms, gallons, or other units used in bills) and in terms of dollars. Describe the process used to determine the base year (averaging, selecting most representative contiguous 12 months, etc.). Consult with facility personnel to account for any anomalous schedule or operating conditions on billings that could skew the base year representation. AUDITING COMPANY XXX will account for periods of time when equipment was broken or malfunctioning in calculating the base year.
- 2) Estimate loading, usage and/or hours of operation for all major end uses representing over five percent of total facility consumption including, but not limited to:
  - a) Lighting
  - b) Heating



- |                                 |                        |
|---------------------------------|------------------------|
| c) Cooling                      | f) Kitchen equipment   |
| d) HVAC motors (fans and pumps) | g) Other/miscellaneous |
| e) Plug loads                   |                        |

Where loading or usage are highly uncertain (including variable loads such as cooling), AUDITING COMPANY XXX will use its best judgement, spot measurements or short-term monitoring. AUDITING COMPANY XXX should not assume that equipment run hours equal the operating hours of the building(s) or facility staff estimates.

- 3) Reconcile annual end-use estimated consumption with the annual base year consumption to within five percent for electricity (kWh), fuels and water. The miscellaneous category can be no greater than five percent. This reconciliation will place reasonable limits on potential savings.
- 4) Propose adjustments to the baseline for energy and water saving measures that will be implemented in the future and that will remain separate from the Energy Performance Contract.
- 5) Develop a preliminary analysis of potential energy and water saving measures.

This list shall be compiled and submitted to Institution and the Institution within <days> of the execution of this Agreement.

- 1) Identify measures which appear likely to be cost effective and therefore warrant detailed analysis
- 2) For each measure, prepare a preliminary estimate of energy or water cost savings including description of analysis methodology, supporting calculations and assumptions used to estimate savings.

e. Meet with Institution and the Institution to present preliminary findings prior to thorough analysis.

Describe how the projected project economics meet Institution's and the Institution's terms for completing the Technical Energy Audit and Project Development Agreement. Discuss assessment of energy use, savings potential, retrofit opportunities, and potential for developing an energy performance contract. Develop a list of recommended measures for further analysis. Institution's rejection of calculations of savings, potential savings allowed, or retrofit recommendation shall be at the risk of the AUDITING COMPANY XXX.

f. Analyse savings and costs for each energy and water saving measure.

- 1) Consider technologies in a comprehensive approach including, but not limited to: lighting systems, heating/ventilating/air conditioning equipment and distribution systems, controls systems, building envelope, motors, kitchen equipment, pools, renewable energy systems or other special equipment, irrigation, water saving devices.
  - 2) Follow the methodology of ASHRAE or other nationally-recognized authority and be based on the engineering principle(s) identified in the description of the retrofit option
  - 3) Utilize assumptions, projections and baselines which best represent the true value of future energy or operational savings. Include accurate marginal costs for each unit of savings at the time the audit is performed, documentation of material and labour cost savings, adjustments to the baseline to reflect current conditions at the facility, calculations which account for the interactive effects of the recommended measures.
  - 4) Use best judgement regarding the employment of instrumentation and recording durations so as to achieve an accurate and faithful characterization of energy use
  - 5) Use mark-ups and fees stated above where applicable in all cost estimates
  - 6) Develop a preliminary measurement and verification plan for each measure
  - 7) Follow additional guidelines for analysis and report preparation given below
- g. Prepare a draft "Technical Energy Audit" report.

The primary purpose of the report is to provide an engineering and economic basis for negotiating a potential Energy Performance Contract between the Institution and the AUDITING COMPANY XXX. The report shall be completed within <days> of the date of execution of this Agreement. The report shall include:

- 1) Overview
  - a) Contact information
  - b) Summary table of recommended energy and water saving measures, with itemization for each measure of design and construction cost, annual maintenance costs, the first year cost avoidance (in dollars and energy units), simple payback and equipment service life
  - c) Summary of annual energy use and costs of existing or base year condition
  - d) Calculation of cost savings expected if all recommended measures are implemented. Include total percentage savings.
  - e) Description of the existing facility, mechanical and electrical systems
  - f) Summary description of measures, including estimated costs and savings for each as detailed above
  - g) Discussion of measures considered but not investigated in detail
  - h) Conclusions and recommendations
- 2) Full description of each energy and water saving measure including:
  - a) Written description
    - i. Existing conditions
    - ii. Recommendations

Include discussion of facility operations and maintenance procedures that will be affected by installation/implementation. Present the plan for installing or implementing the recommendation.

- b) Base year energy use
  - i. Summary of all utility bills
  - ii. Base year consumption and description of how established
  - iii. End use reconciliation with base year (include discussion of any unusual findings)
- c) Savings calculations
  - i. Base year energy use and cost
  - ii. Post-retrofit energy use and cost
  - iii. Savings estimates including analysis methodology, supporting calculations and assumptions used. Clearly state how utility tariffs were used in calculating savings
  - iv. Conclusions, observations, caveats
  - v. Savings estimates must be limited to savings allowed by Institution as described above.
  - vi. Percent cost-avoidance projected
  - vii. Description and calculations for any proposed rate changes
  - viii. Explanation of how savings interactions between retrofit options is accounted for in calculations
  - ix. Operation and maintenance savings, including detailed calculations and description
  - x. If computer simulation is used, include a short description and state key input data. If requested by Institution, access will be provided to the program and all assumptions and inputs used, and/or printouts shall be provided of all input files and important output files and included in the Technical Energy Audit with documentation that explains how the final savings figures are derived from the simulation program output printouts
  - xi. If manual calculations are employed, formulas, assumptions and key data shall be stated.

- d) Cost estimate - detailed scope of the construction work needed, suitable for cost estimating. Include all anticipated costs associated with installation and implementation.
  - i. Engineering/design costs
  - ii. Contractor/vendor estimates for labour, materials, equipment, include special provisions, overtime, etc., as needed to accomplish the work with minimum disruption to the operations of the facilities.
  - iii. Permit costs
  - iv. Construction management fees
  - v. Commissioning costs (or present this category in the Project Development Agreement total project cost below)
  - vi. Other costs/fees
  - vii. Company overhead/profit
  - viii. Environmental costs or benefits (disposal, avoided emissions, handling of hazardous materials, etc.)
  - ix. Note that all mark-ups and fees stated in this Agreement shall be used in the cost estimates, unless otherwise documented and justified due to change in scope or size of project or other unforeseen circumstances
  - x. Conclusions, observations, caveats
- e) Others
  - i. Estimate of average useful service life of equipment
  - ii. Preliminary commissioning plan
  - iii. Preliminary measurement and verification plan, explaining how savings from each measure is to be measured and verified (stipulated by agreement, utility bill analysis, end-use measurement and calculation, etc.)
  - iv. Discussion of impacts that facility would incur after contract ends. Consider operation and maintenance impacts, staffing impacts, budget impacts, etc.

- 3) Complete appendices that document the data used to prepare the analyses. Describe how data were collected.

- i. Meet with Institution to:

Institution agrees to work diligently to provide full and accurate information, and will also allow AUDITING COMPANY XXX reasonable access to facility staff to ensure understanding of existing systems and opportunities

- ii. Revise Audit as directed by Institution.
- iii. Prepare a proposed "Project Development Agreement in anticipation of AUDITING COMPANY XXX and Institution and the Institution entering into an EPC to design, install, and monitor the energy and water saving measures proposed in the Technical Energy Audit.

Project Cost is the total amount the Institution will pay for the project and AUDITING COMPANY XXX's services. Costs must be consistent with maximum mark-ups and fees established above. Costs may include but are not limited to:

- a) Engineering, designing, packaging, procuring, installing (from Technical Energy Audit Report results)
- b) Financing (based on interest rates likely available to Institution at this time)
- c) Performance/payment bond costs
- d) Construction management fees
- e) Commissioning costs

- f) Maintenance fees
- g) Monitoring fees
- h) Training fees
- i) Legal services
- j) Overhead and profit margins not included above
- I. Include a List of Services that will be provided as related to each cost.
- II. Prepare a preliminary analysis of energy performance contract terms to include:
  - 1) List of energy and water saving measures included in recommended package
  - 2) Interest rate used in the analysis
  - 3) Expected contract term (in number of years)
  - 4) Analysis of annual cash flow for Institution during the contract term
  - 5) Explanation of how savings will be calculated and adjusted due to weather (such as heating or cooling degree days), occupancy changes or other factors.
- 4) Termination

AUDITING COMPANY XXX may terminate this Agreement at any time as described in Section 2.b. above.

Institution may terminate this Agreement without cause upon at least 14 days written notice to the AUDITING COMPANY XXX. In this event the AUDITING COMPANY XXX shall be compensated by the Institution for expenses actually incurred prior to termination.

This Agreement may be terminated by either party upon 14 days' written notice should the other party fail to perform substantially. Termination shall be effective 14 days from receipt of written notice.

5) Insurance

Before commencing any Work under this Agreement, AUDITING COMPANY XXX shall file with Institution insurance policies as specified below:

- a) Workers' Compensation Insurance with statutory limits as required by statute, and Employer's Liability Insurance with limits of not less than \$\_\_\_\_\_.
- b) For the duration of the Agreement, AUDITING COMPANY XXX shall maintain Comprehensive General liability Insurance written on an "occurrence" basis. Such insurance shall bear a combined single limit per occurrence and annual aggregate of not less than \$\_\_\_\_\_ and the annual aggregate shall be endorsed to apply separately for each job site or location, exclusive of defence costs. Such insurance will name Institution as an additional insured as respects AUDITING COMPANY XXX's acts or omissions, and shall contain standard cross liability or severability of interest provisions and waiver of litigation.

6) Energy Performance Contract

The Parties intend to negotiate an Energy Performance Contract under which the AUDITING COMPANY XXX will design, install and implement energy and water saving measures which the Parties have agreed to and provide certain maintenance and monitoring services. However, nothing in this Agreement should be construed as an obligation on any of the Parties to execute such an agreement. The terms and provisions of such an Energy Performance Contract will be set forth in a separate agreement.

IN WITNESS WHEREOF, and intending to be legally bound, the parties hereto subscribe their names to this agreement on the date first written above.

AUDITING COMPANY XXX Institution

By: \_\_\_\_\_ By: \_\_\_\_\_ Its: \_\_\_\_\_  
 \_\_\_\_\_ Its: \_\_\_\_\_

**ANNEX 7: SAMPLE TENDER FOR ENERGY AUDIT<sup>15</sup>***GENERAL CONDITIONS OF CONTRACT***1. Agreement:**

Contractor's acceptance of the work order in writing shall constitute contract between him and JPL. If acceptance /comments (if any) is not received from contractor, within one week from the date of this order, it will be considered that the various terms and conditions indicated in the order is acceptable to the contractor.

**2. Offloading & Subletting of Job:**

Contractor shall not offload/ sublet the job given to him without prior approval and permission in written from M/s JPL for any contract in full/ partial.

**3. Measurement of Work:**

Work shall be supervised, inspected and measured as directed by Engineer-in-charge and entered in the measurement book for the Scope of Work with signature of both contractor and Engineer-in-charge or their representative as token of acceptance. Payment shall be made as per actual quantity executed. For all labour intensive jobs, it is mandatory to maintain and submit daily report of workmen attendance duly verified by EIC.

**4. Submission and Payment of Bill:**

- a. The invoice/ RA bills for the Scope of Work as defined earlier should be submitted within 2 weeks of completion of job to Engineer-in charge in triplicate for verification, on monthly basis or as specified complete in all respect and acceptable.
- b. The invoice must be supplemented with the work measurement sheet and workmen attendance sheet duly attested by Engineer in charge.
- c. In case, the job is associated with the supply of materials, the invoice must be supplemented with the material challan duly stamped with Gate Entry number, Packing list, Tax invoice, Quality assurance & test certificates.
- d. The workmen payment sheet and PF challan, if applicable, must be submitted with invoice after verification and attestation by in charge (P&A). If applicable and specified explicitly in the work order, PF and Insurance shall be reimbursed at actual on producing documentary evidence.
- e. JPL will release the payment after all deductions as per specified conditions and statutory rules within 15 days after receipt of the invoice. HOD (Finance & Accounts), JPL shall be the paying officer.

**5. Taxes & Duties:**

- a. Unless otherwise specified, all taxes, duties, levies, charges etc. that may be applicable to this contract is deemed to have been included in the contract price. Service / Sales Tax, as applicable, must be indicated in the bills separately. This will be paid only if supported by documentary proof of payment. The bills shall be prepared & raised along with following information:
  - i. Tax Credit documents should be original. The document should be serially numbered either with numbering machine, or pre-printed stationery or computer printed with date.
  - ii. The document should contain the name, address and Service Tax Registration Number of the service provider.
  - iii. The document should contain our name & address as "Jindal Power Limited, P.O. & Tehsil - Tamnar, Raigarh (C.G.) – 496107".
  - iv. The document should contain classification of services, for example "Engineering Consultancy Services", "Erection, Commissioning & Installation services" etc.
  - v. The document should contain description of service provided, value of taxable service provided, the amount of service tax payable and education cess thereon.

<sup>15</sup> Excerpt from a published tender of Jindal Power Ltd, Chhattisgarh, India in 2014

- b. As regards Indian Income Tax, Surcharge on Income Tax, Withholding Tax or any Corporate Tax, JPL shall not bear any Tax liabilities whatsoever. The contractor shall be liable and responsible for payment of all such taxes, if attracted under the provisions of law. JPL shall however, deduct applicable taxes at source like TDS under Income Tax Rules and Work Contract Tax under C.G. VAT Act as per law from time to time from bills / payments to be made to the contractor and will issue the TDS Certificate for the same to the contractor.
- c. As regards the payment of Welfare Cess under Building and other Construction worker (RE & CS) Act 1996, all the Building and Construction Contractor whose contract value is more than Rs 10 Lac or more, shall be liable to pay welfare cess @ 1% of the contract value and submit the documentary evidence with P&A department.
- d. In case any contractor fails to meet the above statutory requirement, the same will be deducted from its bills directly.

#### **6. Deductions and Penalties:**

- a. JPL shall be entitled to recover from contractor's bills all cost, damages, expenses which may have to incur or become liable to incur as a result of contractor's negligence or any other action that may originate such cost, charges, expenses etc.
- b. In case contractor's bill amount is not sufficient to cover such recovery amount the balance shall be deducted from any sum which may become due to contractor at any time thereafter under this or any other contract contractor may have with us. Should this sum also not be sufficient to cover the full amount recoverable, then we reserve our right to recover the same as remedies available under the law.
- c. If there is any delay in completion of work on the part of the contractor and there is any statutory increase in duties /taxes / levies during the period of delay, in such cases the differential shall be on account of the contractor. In case of failure to execute the work within due date, Security Deposit, if any may be forfeited and JPL reserves the rights to offload the same (complete/ partial) and get it done through other agencies at the cost and risk of the default contractor.
- d. Any intentional delay, or delay due to improper mobilization of men and material for executing the work by Contractor or any unprofessional attitude of Contractors causing delay, penalty @ 1% of the contract value for each week of delay shall be imposed subject to a maximum of 10% of the contract value.
- e. In case in delay in completion of work due to reasons attributable to Contractor, he is liable to pay the liquidated damages @ 1% of the Total Order Value, for each completed week of delay or part thereof subjected to a maximum of 10% the Total Order Value.
- f. In case of non-performance /continuous poor performances, the contract shall be terminated and the work shall be done by any other means at Contractor cost and risk. If the price of contract for the balance work shall be higher, the additional amount shall be recovered from Contractor's security deposit or any dues of this contract or any other contract that the Contractor may have taken in JPL.
- g. The Contractor shall be solely responsible for any loss or damage to JPL property during the currency of this contract due to negligence, fraud etc. on the part of their personnel and will be liable to make the damages in good condition. In case of any JPL material is lost or damaged during execution of work due to Contractor negligence or wrong workmanship, the cost of the same as per prevailing market rate plus departmental expenses shall be recovered from Contractor bills.
- h. For any accident due to the negligence of the contractor/ contractor's deployed agencies/workers or subcontractors, following penalties shall be levied.
- i. For fatal accident – Rs. 500,000/- ii. For reportable accident (Permanent disability) – Rs. 100,000/-

#### **7. Statutory and Labour Regulations:**

- a. Contractor and his workmen shall abide by all statutory rules and regulations, including but not limited to Contract Labour Act, Workmen's Compensation Act, Minimum Wages Act, Employee Insurance Act, Group Personal Accident Insurance, Provident Fund Act, and any other laws, rules and regulations etc. that may be applicable to this type of work, including any licenses like labor license etc. that may be required to be obtained by the contractors.



- b. Contractor shall comply & maintain all statutory records, registers and displays as required under various labour laws. Any deviation or fine levied by the Government. authorities while their inspection will be recovered with penalty from contractor's running bills or security deposit.
- c. Coverage under Employee Provident Fund & Miscellaneous Provisions Act is mandatory. You must obtain a new PF Code for all your workmen and staff from RPFC, Raipur only.

#### **8. Safety, Health & Environment:**

- a. Contractor and his workmen shall abide by all Safety, Health and Environment rules and regulations of JPL. Any violation of the safety rule shall be viewed seriously and contractor shall be penalized as per JPL rule.
- b. Contractor workmen shall have to obtain Gate pass before commencement of work, which shall be issued only after getting safety training & guidelines from JPL safety officer and ensuring medical fitness from JPL medical officer.
- c. Contractor shall have to ensure minimization of pollution at source through environment friendly processes, techniques.
- d. Before starting the work, contractor shall submit detailed work program, milestone of different activities, safety & quality plan and any other relevant documents required for the work to the Engineer-in-charge for his approval, after which work shall be started as per the approved program.
- e. All safety equipment as per statutory requirements like helmets, safety shoes, safety belts and any other specific safety equipment required for the work will have to be provided by the Contractor to his manpower and will meet the following quality standards for PPEs;
  - i. Safety Helmet IS : 2925
  - ii. Safety Shoes IS : 15298
  - iii. Safety Belt IS: 3521 (Only double lanyard and full body harness type safety belt shall be provided by the contractor to their workers while working at height in plant premises.)
  - iv. Welding Helmet IS: 1179
  - v. Face Shield IS: 8521
  - vi. Ear Plug/ Ear Muff IS: 9167
  - vii. Rubber Hand Gloves (Electrical) IS: 4770
  - viii. Rubber / PVC Hand Gloves IS: 4770
  - ix. Rubber/ PVC Coated Fabric Hand Gloves IS: 4501
  - x. Leather, Cotton and Canvass Hand Gloves IS: 2573
  - xi. Rubber / PVC Coated Fabric Apron/ Clothing IS: 6110
  - xii. Canister Type Gas Mask IS: 8523
  - xiii. Cartridge Type Gas Mask IS : 8522
  - xiv. Dust Mask IS: 9473
  - xv. Eye – Protector IS: 5983

#### **9. Discipline:**

The contractor and his workmen shall have to follow JPL's standard Code of Conduct and the Law of the Land. It shall be Contractor's responsibility to maintain and keep the deployed manpower in specified area only. If the contractor or his workmen is found violating the same or participating in unlawful activities, or influencing JPL staff by any offerings or other inducements, the contract shall stand terminated with immediate effect.

#### **10. Manpower/ Material/Consumable/Tools & Tackles:**

- a. Contractor has to ensure availability of all the resources required for the job as follows:
  - Skilled / Semi-skilled / Un-skilled Manpower
  - Site-In-charge / Supervisors
  - Drawing and Design
  - Material
  - Tools & Tackles
  - Plants & Machineries
  - General Purpose Consumables



- Commissioning Consumables and Spares
  - Maintenance Consumables and Spares
  - Measuring Instruments
  - Scaffolding / Working Platforms Material
  - Material Handling & Transportation Equipment
- b. Lighting at work site will be Contractor's responsibility for which power supply of 220V will be provided by JPL free of cost. Only 24V supply will be permitted for lighting in confined spaces. Contractor has to ensure availability of 220V/24V transformers and bulbs for the purpose.
- c. For the material / spares issued by JPL and used by contractor, record is to be maintained and submitted at the time of billing. The damaged spares replaced are to be kept in Contractor's custody and should be deposited to JPL stores immediately after the completion of work. The stock of the damaged spares / consumed material will be reconciled with the quantity issued. If the Contractor fails to do so, the cost of the same will be deducted from the Contractor's bill. The Contractor must return the unused spares / material issued.

#### **11. Insurance:**

The jobs wherein the entire scope of supply and service lies with contractor, he will have to take Insurance policy for Contract value including taxes for Storage cum Erection Policy for the period of contract. The contractor will provide third party insurance at the time of commencement of work or before release of any payment other than mobilization, valid for the contract period including extended contract period if any.

#### **12. Manpower Competency:**

- a. In addition to the site-in-charge, the Contractor has to ensure supervision of work in progress by deploying at least one technically competent site supervisor. The site-in-charge of the Contractor shall authorize his representative to collect/return materials from/to JPL as per requirement of work.
- b. The job is of skilled nature and manpower with suitable requisite skill & experience only shall be permitted to be deployed. Contractor has to ensure that the credentials and certificates of the workmen deployed are submitted to JPL and shall be vetted by them before the start of work.

#### **13. Indemnity:**

Contractor shall keep JPL indemnified from all liabilities resulting out of this contract and act of Contractor workman, including but not limited to taxes & duties, damages, penalties, fines, punitive measures, lawyer fees etc. of whatever nature due to non-compliance by contractor in his scope of the applicable statutory laws, rules, notifications etc.

#### **14. Force Majeure:**

In case force majeure is established and one party informs the other promptly of such occurrences, no increase in price and / or any claim shall be made by the contractor. In case of very prolonged force majeure condition the parties shall mutually discuss and agree to the future course of action.

#### **15. Termination of the contract:**

For reasons covered elsewhere in this contract document, if the Contract is to be terminated, Fifteen (15) Days' prior notice shall be given by JPL. In such an eventuality, the Security Deposit and Outstanding payments, if any may also be forfeited at the sole discretion of JPL. However, if the Contractor desires to quit the Contract or JPL decides to short-close the contract, one month's prior notice shall be given by either party.

#### **16. Dispute Settlement:**

- a. Any dispute or difference arising out of in connection of this contract shall be referred to the sole arbitrator Executive Director, OP Jindal Super Thermal Power Plant, Jindal Power Ltd., Tamnar, Raigarh (CG) and the decision given by the sole arbitrator will be conclusive and final and be binding on both the parties.
- b. Arbitration, if arise, shall be resolved in accordance to the Indian Arbitration & Conciliation Act with latest revisions. This agreement being executed at Raigarh & the parties agreed that any dis-

pute or differences arising out of this agreement would be subject to the jurisdiction of only Raigarh court.

### **STATUTORY AND SAFETY COMPLAINT**

**The statutory and legal conditions shall be applicable to all labour intensive jobs and the contractor shall have to strictly comply with all the clauses mentioned hereby:**

- 1. Labour Act:** Contractor shall abide by all provision of contract labour (R&A) act 1970 and other applicable labour laws and rules made there under from time to time.
- 2. Labour License:** Before commencement of work, Contractor shall submit labour license (if applicable) from competent authority to the JPL's P&A officer through Engineer-In charge.
- 3. Gate Pass:** Before commencement of work, Contractor has to arrange gate pass for his workmen from JPL's P&A officer as per JPL's standard norms.
- 4. PF registration:** Before commencement of work, Contractor shall submit the Provident Fund Registration No. and ensure to recover provident fund amount from wages of all workmen and deposit to the Provident fund authorities and submit a copy of the same by 20<sup>th</sup> of every month to the JPL's P&A officer through Engineer-In-charge. In case, contractor fails to produce documentary evidence of PF recovery and deposition, JPL will arrange to deposit the same to the Provident fund authorities and the amount along with overheads @30% will be recovered from the Contractors' bill.
- 5. Workmen Insurance:** Before commencement of work, Contractor shall obtain Insurance policies under Group Personal Accident Policy & Workmen's Compensation Policy covering employment accidental benefit upto Rs. 4.0 Lacs through each policy (total 8 Lacs) and furnish the copy of it to the JPL's P&A officer through Engineer-In charge. In case of non-submission of Insurance Policies before start of work, 5 % (Five percent) of the Monthly Bill values shall be retained by JPL until the Contractor presents the copy of Policy document.
- 6. Wage Payment:** Payment to contractor's workmen shall be disbursed on or before seventh day of the wage period in presence of the JPL's P&A officer & Engineer-In charge or their duly authorized representative who shall certify on the payment sheet/register for fulfilment of provision of law. In case of failure to make payment to the workmen within 07(seven) days after wage period, JPL will arrange for labour payment and the amount along with overheads @30% will be recovered from the contractors bill.
- 7. Bonus & Retrenchment:** Contractor shall have to pay its workmen the bonus as per applicable act. Moreover, retrenchment benefits to workmen under Inter State Migrant act if being retrenched shall be paid by contractor.
- 8. Records, Register and Display Notices:** Contractor must maintain statutory registers and records as applicable under various labour laws. Contractor must displays notices in front of his office in Hindi& English as required under various labour laws.
- 9. Statutory Reimbursement:** Any payment against statutory obligations, if applicable and specified explicitly under JPL's scope, such as PF, insurance etc. shall be reimbursed at actual by JPL on producing documentary evidence by the contractor.
- 10. Code of Conduct:** The contractor shall have to follow JPL's standard Code of Conduct. If the contractor is found violating the same or influencing JPL staff by any offerings or other inducements, the contract shall stand terminated with immediate effect and the contractor may be debarred to work for a period as decided by JPL.
- 11. Work Permit:** Work on any equipment or in any area should be started only after ensuring valid permit. Before starting the work, contractor shall submit detailed work program, milestone of different activities, safety & quality plan and any other relevant documents required for the work to the Engineer-in-charge for his approval, after which work shall be started as per the approved program.
- 12. Tools & Tackles:** Contractor will have to produce fitness test certificate of all lifting tools and tackles being used by him from any outside competent person.

- 13. Vehicle:** All the vehicles (except used by specific person) to be deployed by contactor shall be fit for use in all respect. The Vehicle must be commercially registered with the transport authority and must carry all statutory documents (valid Driving license, Insurance policy, P.U.C. certificate etc.)
- 14. Labour Health & Hygiene:** Contractor shall have to ensure periodical cleaning and disposal of waste from workers residential colonies. Contractor must ensure the hygiene, potable drinking water and regular housekeeping in his workers colony. Non-compliance of the same would be viewed seriously by the company and suitable action would be initiated to ensure proper living conditions. During summer this area becomes very hot and prone to the cases of dehydration. Contractor must ensure the provision of ORS drink to all the workers during summer.

#### **GENERAL CONDITIONS OF PURCHASE ORDER**

- 1. Scope – Acknowledgement of Order :** The present general Conditions shall be applicable to purchase orders placed by JPL, unless otherwise specified in the order. The vendor shall return to JPL, the acknowledgement of the order, duly signed, within one week from the date of dispatch of the purchase order as a token of acceptance through courier/post/fax/scanned email. JPL reserves the right to cancel the order should the vendor make any alteration to the acknowledgement. Any action taken to execute the order from JPL, even if there has been no acknowledgement of the order, shall be deemed to constitute acceptance of the present General Conditions.
- 2. Execution of Orders:** The vendor shall be solely responsible for the execution of the order in every respect, in accordance with the normal customs of the trade. He shall draw JPL's attention to any element likely to impede the satisfactory execution of the order, in particular by providing JPL at all times with all relevant information for this purpose.
- 3. Price:** Unless otherwise stated, the unit prices as indicated in Purchase Order are the Ex-Works / shop / depot prices. Prices mentioned in the order shall remain firm and not subject to escalation till the execution of the order even though the completion/execution of the order may take longer time than the delivery period specified and accepted in the purchase order.
- 4. Price Revisions:** Price revisions, if applicable, will be effective only if agreed and confirmed by the buyer in writing and shall not remain effective beyond the specified time limits if the delay is due to the vendor.
- 5. Packing & Forwarding:** Unless otherwise stated explicitly in Purchase Order, P&F expenses will be deemed as **Inclusive** in the unit price.
- 6. Packing Conditions:** You are requested to reduce packaging waste and minimize utilization of wood items for the packaging without affecting the quality. Any damage to material at the time of delivery at site, due to improper packing shall be the responsibility of vendor. Vendor has to ensure prompt replacement of such damaged items failing which appropriate actions will be taken as deemed fit.
- 7. Sales tax CST/ VAT and other taxes:** Sales tax/VAT, levies and any other duties shall be shown separately in the invoice if payable extra. Any increase in the rates of taxes, levies and duties beyond delivery period stipulated in the purchase order shall be to Vendors' account. Vendor will furnish your Sales tax registration number in all your invoices. The registration number indicated in the invoices shall have to be in force on the date of sale of goods.
- 8. Excise duty:** Extra as applicable at the time of removal from Vendor's premises and will be paid against submission of original copy of transporters' invoice, duly authenticated. Vendor is to ensure that the duplicate copy of the Invoice is sent to the destination / consignee along with the material, without which Excise Duty amount will be retained. Present Rate of Excise Duty is @10% and CESS as @ 3% of Excise Duty.
- 9. Declaration:** We are in the business of Generation, Transmission and Distribution of Electricity, which are non-excisable goods. Therefore we do not have Excise Control Code (ECC) number / Excise Registration No. If you are a SSI, please specify Notification Number and the Concessional duty applicable thereto. If duty is paid under protest then the Notification Number and date should be mentioned.

- 10. Delivery & invoices:** Time is the essence of this order. Material shall be delivered within stipulated date in the order / delivery-schedule. The invoices shall be made in triplicate (3 copies) and shall accompany the material. The material along with the Original bill/Invoice shall be delivered to the following address; **MANAGER – CENTRAL STORES Jindal Power Limited, O.P.Jindal Super Thermal Power Plant P.O. Tamnar, Dist. Raigarh (C.G.) PIN – 496107**
- 11. Delivery Timings** 09.00 to 13.00 hrs & 14.30 to 17.00 hrs. except Sundays & Public Holidays.
- 11. Mode of delivery**
- F.O.R. JPL Central Stores: Vendor will send the materials through any reputed Bank approved transporter as mentioned below and will book the consignment on "Freight prepaid basis" for door delivery.
  - F.O.R. Ex works: Vendor will book the consignment through any reputed Bank approved transporter as mentioned below on "Freight prepaid / Freight to be billed basis" for door delivery.
  - Freight charges are payable by JPL against documentary evidence. d. Tax at Source (TDS) shall be deducted at source as per statute and applicable government laws.

**Our preferred transporters:**

M/s Associated Road Carriers (ARC), M/s Transport Corporation of India Limited, XPS.

- 12. Insurance:** Insurance for the material in transit would be as per the terms agreed and mentioned in the Purchase Order. If this is agreed on 'Vendor's Scope', vendor shall ensure suitable coverage of the material on warehouse to warehouse basis. If, Insurance is in 'JPL Scope', then vendor shall endorse the Open Marine Policy number, as mentioned in Purchase Order, in all the relevant dispatch documents, viz; Challan/ invoice/ LR copy etc. or else the materials will be received at Vendor's risk.
- 13. Acceptance of the Supplies:** Acceptance of the supplies shall always take place on the JPL site, after due checking, even when the goods are invoiced "ex Works" or "ex Warehouse."
- 14. Payment:** Invoices shall be settled only to the value of the goods accepted, and on condition that all the relevant and other necessary documents have been received at JPL .Provided the invoiced goods have been accepted by JPL after inspection, payment will be made within 30 days from the date of acceptance of the supplies at JPL site, unless otherwise specified in Purchase Order.
- 15. Liquidated Damages:** Delivery period should be guaranteed. In case of delays, the vendor shall be liable to pay the purchaser by way of liquidated damages @ 0.5% of the undelivered value of the order for each week's delay subject to maximum of 5% of the total value of the order. In specific cases this general standard LD clause may be modified and shall be indicated in order / delivery schedule.
- 16. Risk purchase:** In the event you fail to supply the material on order, JPL will have the right to buy the material from other sources at market rates and the extra cost incurred in such procurement along with company overheads will be recovered from your future bills against subsequent supplies/bills.
- 17. Quality and Inspection:** The materials supplied hereunder shall be of good quality, free from any faults and defects and in conformance with the Purchase Order, and shall at all times be subject to inspection before acceptance by JPL / JPL's Inspection Agency, who will carry out inspection at site. JPL reserve the right to reject part or full consignment received in defective condition. In case JPL representative would like to inspect the item at your site prior to dispatch, the same will be communicated to vendor in advance against intimation of readiness received from vendor's end.
- 18. Return of Non-Conforming Product:** In case of Non-conforming product/ rejection, vendor shall have to arrange for replacement on immediate basis. Vendor shall also arrange to lift the non-conforming/ rejected material from our plant within 15 days of the date of Rejection Note, till then the Non-conforming material will remain at Central Stores - JPL at vendor's risk. Further, if vendor fails to lift such materials within 60 days without any intimation to us, it will be presumed that you are not interested to lift the same and in that case JPL reserves the right to shift the non-conforming/ rejected ma-

terials to scrap yard at the vendor's risk without any further communication for which no further communication will be entertained.

19. **Suitability / Compatibility Certificate:** You would be required to furnish at the time of supply, a certificate confirming the suitability with the parent equipment in use, of the material offered by you. In case of any modification in design or manufacture of the spares, which result in not meeting our end use requirement, such spares shall be replaceable by you at no extra cost.
20. **Guarantee:** Equipment/material shall be guaranteed for satisfactory performance for a period of 12 months from the date of commissioning or 18 months from the date of receipt whichever is earlier against faulty design, material and workmanship and shall be replaced free of cost in the event of failure during the guaranteed period, unless otherwise specified and agreed in your offer and our purchase order subsequently.
21. **Health & Safety:** Vendor will provide complete information regarding the usage for which the product has been designed, and any restrictions and safeguards which should be observed in all stages of its handling, operation and disposal. This may be in the form of technical specification, leaflet/ brochure, MSDS (Material Safety Data Sheet), instructions for safe Material handling and Storage instructions etc.
22. **Compliance to Environment Laws:** Please indicate whether your organization is ISO 14001 certified. If not, please certify that the handling, use and disposal of your product consider practices consistent with sound environmental management. We prefer environment friendly products and processes.
23. **Grievance Redressal:** In case of any grievance the vendor shall bring the same to the notice of the Head - Materials & Contracts. Vendor may also drop his concerns at the drop-box available for this purpose at the reception of Administrative Building, JPL, Tamnar or may send the same through post or electronic mail.
24. **Vendor Rating:** Vendor is requested to ensure compliance to the terms of the individual orders with regards to timely delivery, provision of all applicable documents / challans / test certificate, quality of the material etc. Vendor performance with respect to these factors will be taken into consideration during rating of vendors for future business.
25. **Order Manager:** This order will be managed by the Buyer as mentioned in the Purchase Order. All future correspondence related to this order shall be addressed to the above officer.
26. **Payment Manager:** AGM (F&A) will be the payment manager as per the Purchase Order terms. All future correspondences related to payment shall be addressed to the above officer under copy to the order manager.
27. **Indemnity against Patent Rights:** The equipment, system, drawings, and other materials supplied by the vendor against this order will become sole property of JPL and JPL management and any individual engaged in this business shall remain indemnified against any claim for infringement or breach of any of the statues, rules & regulations by the use of or sale of any article or material supplied by the vendor. This indemnity shall include any infringement of patent, trade mark, design, copyright or other property rights whether in Country of origin, or elsewhere resulting from vendor's design, manufacture, use, supply or re-supply & would also cover use or sale of any article or material supplied by vendor to JPL under this order. This Indemnity shall cover any claim/action taken by a third party either directly against JPL or any claim/action made against the vendor & where under we are made liable. The Indemnity shall be for loss, damages, and cost including litigation costs incurred by us under this order.
28. **Arbitration:** Any disputes and differences arising out of or relating to this Purchase Order including interpretation of its terms will be resolved through joint discussion of the designated officials of the concerned parties. However, if the disputes are not resolved by Joint discussions then the matter will be referred for adjudication to the arbitration of a person appointed by the parties in Raigarh (C.G.) in accordance with the Indian Laws. The decision of the arbitrator shall be final and binding on the parties.



- 29. Jurisdiction:** This Purchase Order shall in all respect be subject to the jurisdiction of courts at Raigarh (C.G.). Any dispute relating to this order shall be deemed to have arisen in Raigarh (C.G.) and subject to jurisdiction of Raigarh (C.G.) courts only.
- 30. Suspension Termination:** The Buyer shall have the right, even if there is no delay in execution of the order, to suspend or terminate the Purchase Order with prior intimation to the vendor. If, the vendor defaults in his obligations under the Purchase Order, payment shall be limited to such part of the Purchase Order price corresponding to the order executed until such suspension or termination. The vendor may only claim reimbursement of its proven suspension or termination cost, if the Purchase Order was suspended or cancelled for reasons attributable to Buyer.
- 31. Breach of Contract:** If Vendor breaches any obligation resulting from or in connection with the Purchase Order, the Buyer shall be entitled to claim full compensation of his damages suffered due to such breach including but not limited to damages arising outside the Goods, except where such breach is not due to Vendor's fault. However, Buyer will not hold Vendor liable for loss of production or loss of profit except to the extent damages or losses are due to Vendor's gross negligence or wilful misconduct.
- 32. Order Validity:** The Purchase Order shall stand CLOSED automatically after the expiry of One Year beyond the scheduled completion date, pending in full or partial.
- 33. Force Majeure:** Neither party shall be liable for failure to perform its obligations under the Contract if such failure results from circumstances which were not in the contemplation of the parties at the time of the Contract and which are beyond the reasonable control of the party in breach.

## **SCOPE OF WORK**

### **General instruction for tenders which is to be awarded to carry out energy audit.**

#### ***Introduction***

Jindal Power Limited (JPL), a subsidiary of Jindal Steel & Power Ltd. (JSPL), has been contributing significantly to the growing needs of power in the Country. JPL has set up India's first mega power project in the private sector at Raigarh, Chhattisgarh. The Company has invested approximately Rs. 4338 crore for setting up a 1,000 MW power plant, the 1st unit of which was commissioned on 2.9.2007. All four units (250 MW each) were commissioned within a span of nine months. The fuel supply of the plant is met through its captive coal mines. A 6.9 km conveyor pipeline has been set up for transportation of coal between the mines and the plant. The Company has constructed a 258 km, 400 KV Double Circuit transmission line from the plant to the PGCIL substation at Raipur through which power can be sold anywhere in India. For meeting the plant's consumptive water requirement, an 18 m high dam over the Kurket River has been built, 25 km away from the project site. Jindal Power Limited is expanding its capacity at Tamnar by setting up a 2,400 MW thermal power plant at an estimated cost of Rs 13,410 crore. The two units of 600 MW have been already commissioned. Commissioning activities of other two units are under progress. Boiler, Turbine and Generation (BTG) package of both 250 MW and 600 MW are supplied by BHEL.

#### ***Qualifying requirements***

The offer of only those firms will be considered who will produce documentary proof in support of following criteria

1. The firm should have experience of minimum two years for conducting energy Audit Test in Coal Based Thermal Power Station of 210/250 MW or above unit in Govt. /Semi Govt. /PSUs/Renowned Private Sector for which copy of two work orders for conducting Energy Audit Test or similar type of work along with satisfactory performance certificate/completion certificate will be required.
2. The firm should have executed similar type of work of minimum value of Rs. 10 Lac against single order during the last two years along with satisfactory performance certificate or repeated orders for similar works from the same organization.
3. The firm should have certified Energy Manager/Energy Auditor from Bureau of Energy Efficiency (BEE) for the proposed job.
4. The firm must be enlisted in BEE (Bureau of Energy Efficiency) accredited Energy Auditor list for the proposed job.

**Expectations from the Work**

1. We expect that this assignment to get completed within three (3) months from the date of issue of work order. The work shall be started immediately from the date of notice, which shall be given to the contractor by JPL. The quantity of work may be decreased to any extent depending upon the plant/front available. The payment shall not be made for the work not done.
2. We expect you to identify various energy and cost saving opportunities available at our facility. For each identified opportunity, a clear and sound reasoning for its recommendation is expected. Opportunities should be identified on the basis of our normal loading factor conditions and without affecting the plant reliability.
3. Comprehensive benefit/cost analysis and Payback period calculation keeping in view the energy cost of JPL.
4. A detailed audit report containing all energy saving measures, which are identified and quantified.
5. The draft report should be submitted within one and half (1.5) month from date of completion of field audit.
6. The final report & presentation to higher management should be submitted within fifteen days after submission of comments on draft report by JPL.
7. A set of soft copy (Excel sheets) containing all the measurements and calculations related to energy audit.

**Site of Work Inspection**

Before submission of offer, the bidder is encouraged to inspect the site of work to get acquainted with the actual work, equipment, facilities available & other prevalent conditions. JPL will not pay any cost associated with this Visit.

**Technical Terms & Conditions**

1. Energy audit should be carried out as per the guidelines given on website [www.cea.nic.in](http://www.cea.nic.in), energy Conservation Act, 2001 and BEE latest guidelines in this regard.
2. The Energy Audit reports shall also include as desired under Energy Conservation Act form-1, form-2, form-3 etc. given in concerned regulation of Act. The energy audit report should be structured as detailed in Energy Conservation Act, 2001 and BEE latest guidelines in this regard.
3. The performance audit of different equipment like Boiler, Turbine, Condenser, Air heater, ESP, others etc. should be carried out strictly as per the latest version of ASME codes for e.g. ASME PTC :6 2004 for steam Turbine, ASME PTC :4 2008 for Steam Generators, ASME PTC : 12.2 for Surface Condenser, ASME PTC:19.2,19.3,19.5 for pressure, temperature & flow measurement etc. The standards and guidelines to be followed are attached in Annexure-1
4. Any repair and maintenance required after preliminary study to conduct final audit study has to be clearly identified by the energy auditing executive agency and the same will be carried out by JPL.
5. Power, water and compressed air will be made available by JPL at free of charge to carry out the proposed energy audit work.
6. Collection of samples such as coal, bottom ash, fly ash etc. will be carried by the Contractor. Reading to be taken by specialized equipment & also to be carried out by the contractor.
7. The contractor has to evaluate the lab facility (Chemical, Electrical & C&I) available at our site and any test or calibration required and if such facility is not available with us then the contractor has to arrange on its own.
8. List of Instrument – Accuracy Level & Calibration certificates. All the measuring instruments, fittings & other ancillaries shall be arranged by the bidder. The bidder should ensure that the instruments possess the desired accuracy as stipulated under ASME PTC for process parameter measurement and are calibrated by NABL approved lab with valid certificates. JPL will provide the required location/points for the placement of instruments & connection of power cables.
9. Equipment /instruments/T&P used during energy audit test with following minimum accuracy level:
 

Power analyser	-	0.1%
Transmitters	-	0.1%
RTDs, thermocouples	-	½ DIN



- Data Logger - 0.03%
10. All the equipment/instruments/T&P used during energy audit should have accuracy as per IS standard for measurement purpose.
  11. Process parameter measurement should be done without causing major disturbance to the actual process stream. Some operational arrangements/corrections/ adjustments, if desired so for process measurement, should be intimated at least one week in advance to the Sr. DGM./O&E (concerned) JPL,TAMNAR. However final decision pertaining to the availability of the equipment for test, operational adjustments, time line etc. will rest solely with JPL, TAMNAR.
  12. JPL as far as possible will provide all the available design data, Characteristic curve, P&IDs, GA drawing, Electrical SLDs & other technical specifications to the bidder for calculation of test result. However, in case, required data is missing or not available, then bidder can use standard guidelines & curves (for e.g. ASME) for the sake of calculation of test result with a-priori permission from JPL.
  13. The bidder should submit detailed report describing major efficiency parameters , methodology followed & specific recommendation for energy reduction with cost- benefit analysis pertaining to all the audited systems/ drives after the completion of audit.
  14. The prospective bidder should submit following documents along with the proposal for review & approval of JPL.
    - a) Proposed Audit plan with timelines
    - b) Reference List of Thermal Power Plant where comprehensive audit has been carried out.
    - c) List of test instrument with their accuracy class, calibration date & certifying Agency (Instrument accuracy should be as per relevant ASME guidelines)
    - d) Copy of Report of Energy Audit carried out at similar units as per ASME Standards with test schemes
    - e) Auditor's profile & work experience
  15. All the performance parameters of key equipment/systems are to be computed & compiled in the detailed report (which should also Include calculation methodology, sample calculation, assumptions & field data sheet) to be submitted by the Bidder. Report should clearly describe any observations regarding deficiencies and recommend the corrective measures along with potential benefits in Kcal/Rs terms.
  16. Contractor will furnish the bar chart/PERT schedule of all the activities to be carried out for completing energy audit assignment before the start of work.
  17. If major shutdowns/outages of any units due to any reasons, the energy audit agency shall have to carry out the energy audit work at the quoted rate after synchronization of units even though the contract period is over, without any extra payment.

#### ***Scope of work for 4 Units of 250 MW along with BOP***

The energy audit should include

- i) Field visit for data collection for detailed energy audit.
- ii) Data analysis and report preparation.
- iii) Identification of any Deviation from Design, Cause & Operational Measure
- iv) Identification of Energy Conservation opportunities and performance improvement.

The areas with detailed scopes of works are as follows:-

#### **A. BOILER**

1. Evaluation of boiler efficiency by loss method including Dry & Wet stack losses, losses due to combustibles in fly ash & bottom ash, losses due to leakages, furnace radiation loss etc. At 100% and / or 75% TMCR load with coal fired (and oil fired).
2. Boiler temperature/pressure profile
3. Sectional (SH, RH, economizer) heat transfer efficiency.
4. Performance evaluation and Power consumption of ID fan, FD Fan and PA fan.
5. Fan loading and combined efficiency of fan and motor.
6. Boiler Feed Pump (power consumption and performance evaluation).
7. Assessment of air ingress at different levels of Furnace.

8. Performance testing of Air Pre-heaters (APH) to determine efficiency, leakages (%), X-Ratio, flue gas temperature etc.
9. Oxygen profile along the draft system

#### **B. TURBINE**

1. Calculations of turbine heat rate (Efficiency) of Plant at 100%, and / or 75% TMCR load with coal fired (and oil fired).
2. Calculation of Turbine Heat Rate (Efficiency) at 100% load with 0% MU in Valve throttles Condition & VWO Condition. Heat rate calculation on Heat rate Deviation method also.
3. Turbine pressure survey.
4. Performance of turbine glands
5. TG cycle losses / deviation computation
6. High pressure drain valve survey
7. Performance study of Vacuum Pump.
8. Calculation of Turbine cylinder efficiency (HP, IP & LP) and cycle efficiency.

#### **C. REGENERATIVE FEED WATER HEATING SYSTEM**

1. Assessment & Performance evaluation (including TTD, DCA, LMTD, ITD & Degree of Sub cooling calculation).
2. Heat duty, Overall heat transfer coefficient of HP Heater, LP Heater, De-aerator, and Drain Cooler & Gland Steam Condenser.
3. Degree of Sub-cooling etc.

#### **D. CONDENSER & CONDENSATE PUMP**

1. Performance & study of deviation of indicated condenser vacuum from the expected values and deterioration in the performance of condenser due to dirty tubes, scale formation, air ingress, CW inlet temperature & CW flow.
2. Assessment of condenser heat load, deviation of condenser heat load, if any.
3. Condensate Extraction Pumps power consumption and performance Evaluation.

#### **E. PUMPS**

1. Boiler feed pumps power consumption and performance evaluation.
2. CW pump, ACW pump, DMCW & DMCW booster pumps power consumption and performance evaluation.

#### **F. COOLING WATER SYSTEM**

1. Assessment of cooling tower capacity and efficiency /effectiveness and operational L/G ratio.
2. Evaluate circulating water pump flow rate, head developed pressure of pumping system and power consumption.
3. Assessment of condenser heat load, deviation indicated in respect of the CW pump performance.
4. Water circulation, condenser efficiency,
5. Assessment of Vacuum system and fan performance

#### **C. COAL MILLS PERFORMANCE TESTING**

1. Assessment of air/coal ratio.
2. Coal fineness test
3. Mill performance data analysis vis-à-vis performance Guarantee values
4. Energy Consumption
5. Pressure drop across the milling system and velocity estimation.
6. Mill internals replacement analysis with respect to specific energy consumption using historical data.
7. Study & Analysis of Mill rejects

#### **D. ESP AND ASH HANDLING PLANT**

1. Evaluate the ESP performance pin comparison with the design.

2. Study the collection efficiency
3. Ash property
4. Study the Evacuation and disposal methods including consumption of water, ash-water ration for ash disposal in wet disposal system, Recommendation for optimization.
5. Power consumption and pump performance of ash handling system.
6. NO<sub>x</sub>, SO<sub>x</sub>, SPM, CO<sub>x</sub> measurement

#### **E. WATER TREATMENT PLANT & DM PLANT**

1. Capacity utilization and power consumption of all major drives.
2. Performance evaluation of Pumps

#### **F. COAL HANDLING**

1. Estimate the average capacity utilization of the CHP.
2. Measure consumption of motors, (Current, Power factor)
3. Assessment of specific power consumption for various options i.e. Direct bunkering, Stacking & Re-claiming etc.

#### **G. COMPRESSED AIR SYSTEM**

1. Compressor FAD (Free Air Delivery), if compressor gets isolated.
2. Performance evaluation of air compressors by using power measurement analysers.
3. Air pressure profile measurement for 24 hrs at different locations (farthest & highest points)
4. Air leakage identification.
5. Optimization of compressed air utilization and distribution.

#### **H. TOTAL ELECTRICAL SYSTEM INCLUDING LIGHTING**

1. Performance evaluation of generator.
2. Assessment of the loading pattern of GTs, UATs, ICTs, STs and other transformer to identify measures for reduction of losses.
3. Electrical parameters like current, voltage, power factor and power by using power measurement analysers.
4. Assessment of health of capacitors and adequacy of the existing VAR compensation system
5. HT/LT motor consuming power more than 20 KW needs to be checked for measuring electrical parameters and performance.
6. Feasibility study for replacing the existing motor by energy efficient motors.
7. Lighting of Main plant including office building lux. Measurement and power consumption (day/night phase wise).
8. Distribution losses.
9. Harmonic analysis.

#### **I. AC & VENTILATION SYSTEM**

1. Cooling Load and performance of VAM/ AC CHILLER.
2. Performance of chiller, CW PUMP & Cooling Tower.
3. Performance analysis of AHUs.
4. Power consumption by each AC system by using power measurement analysers including Cooling effect and humidity.

#### **J. FIRE FIGHTING SYSTEM**

1. Input Power measurement of all the key equipment of the Fire system like hydrant, spray (Electric & Diesel), Jockey Pump, Booster Pump
2. Establishment of specific energy performance indicators.

#### **K. INSTRUMENT AND CONTROL**

1. Evaluate the instrumentation available in the plant and identify the locations where online measurements are necessary for efficiency calculations however unavailable

2. Recommendation regarding type of instrument, installation details, make etc.
3. Measuring instrumentation at coal handling plant, ash handling system, Raw water and waste water system

#### L. THERMAL INSULATION

1. Insulation of Boiler, Air and Flue gas path and Steam piping.
2. Surface temperature measurement at the damaged and Hot spot area by infrared temperature indicator.
3. Estimation of Heat loss in the hot spots and damaged insulation area

#### ***Proposal Requirements***

Please submit your proposal as per the scope of work mentioned above. At your option, additional proposals with different scope of work are welcome.

1. Technical offer and Commercial offer for Energy Audit of the unit should be submitted separately.
2. Commercial offer should include 1) Professional charges 2) Lodging, Boarding, traveling (Internal and external) separately with break-up, (3) Total no. of days & man-days at site for each work mentioned above.
3. Relevant documents should be attached-----
  - a) BEE accreditation letter.
  - b) List of Instruments to be used for Energy audit with makers name & Accuracy Level.
4. Please provide your firm's credentials related to experience by providing
  - a) List of jobs done including Client, Site, nature of job and year.
  - b) Explicitly state your experience in:
  - c) Energy Auditing in Power Plants
  - d) Energy Management
5. In addition to the proposal, any documents which are relevant to the subject or to your offer may be submitted.
6. Please provide the following details related to Audit Team:
  - a) Project team structure delineating individual roles and responsibilities
  - b) Team strength by person category
  - c) List of Energy Manger/Auditors along with whole team who will be involved during energy audit (With designation, qualification, experience, etc.)
  - d) CV of each team member, indicating whether full time employee or associate, and specifying total experience in years, duration of employment with your firm, relevant experience in areas related to this project with details of specific projects.
7. Please indicate the schedule for auditing activities, milestones and deliverables.

#### ***Energy Audit Report Outline (Draft & Final)***

The comprehensive audit report should contain all energy saving measures, which are identified and quantified.

The following outlines a final report of an energy audit.

- a) A table of contents.
- b) Executive Summary.
- c) Standard formulae used and assumptions (along with justification).
- d) Field measurement of all consumption.
- e) Schematic diagram with mass & energy balance all measured system.
- f) Identifying relationship of processes & operational methods being followed and details of changes required for energy saving.
- g) Identifying the major factors, which are contributing to high-energy consumption for all systems.
- h) Recommendations to reduce energy consumption relating to system changes (process improvement, maintenance practices, replacement or modification etc.).
- i) Comprehensive benefit/cost analysis and Payback period calculation keeping in view the energy cost of JPL.
- j) The energy audit report will incorporate reports as per BEE latest guidelines of Energy Conservation Act, 2001.

- k) Total impacts on the system on implementation of all the recommendations with various level of process.
- l) Related impact, on the system reliability, availability and stability.
- m) Final preparation of technical and Economical viable energy conversion report which Include: i) Technical viability ii) Economical feasibility iii) Calculation of investment & payback period iv) Suggestion of name of supplier/consultant for further implementation.
- n) The audit report shall include references taken for technical inputs as papers, journals, handbooks, publications etc.
- o) The software's & charts used for analysis to be given along with the report.
- p) Five hard copies (Each Unit) of the draft Energy Audit report to be delivered.
- q) Three soft copy of draft Energy Audit report to be delivered (PDF and Word format).
- r) Five hard copies (Each unit) of the Final Energy Audit report to be delivered.
- s) Three soft copy of Final Energy Audit report to be delivered (PDF format).
- t) An Excel file should be provided for all the measurements, calculations and charts included in the report.
- u) Measurements by your instrument, Measurement by already installed instrument and standard values used needs to be categorized in different colour codes.
- v) Date and time for each measurement (at which taken) should be provided.

#### ***General Terms & Condition***

1. No overrun charges shall be paid in the event of the completion period being extended for any reason.
2. Furnished limited accommodation will be provided in our guest House, Tamnar for duration of energy audit test of units if available on chargeable basis at standard/market rent (Whichever is higher).
3. After award of contract, No subletting of the contract shall be allowed and any subletting will lead to cancellation of the contract.
4. No extra payment will be made for any additional work carried out by the contractor for energy audit which is not mentioned in work order.
5. If the contractor does not engage sufficient skilled staff or the quality of work is not up to the satisfaction of Engineer-in-charge or there is delay in attending of jobs, the penalty @ 1% of the contract value per day for part thereof up to maximum of 10% of total contract value.
6. If the contractor fails to adhere to the time schedule or if his services are found to be unsatisfactory, JPL will be entitled to cancel the contract & forfeit the security.









