

---

# **Mason training manual**

## ***Medium-scale plug-flow biogas plant***

<b>Implementer</b>	<b>Organisation</b>
Ms. Dagmar Zwebe	: Netherlands Development Organisation - SNV
Mr. Matthew Carr	: Netherlands Development Organisation - SNV
Ms. Ho Tho Lan Huong	: Institute of Energy
Ms. Dang Huong Giang	: Institute of Energy
Mr. Vu Duy Hung	: Institute of Energy
Mr. Tran Duc Kien	: GECI
Mr. Tran Tuan Duong	: GECI

### **Co-Editors**

Prof. Dr.-Ing. Zifu Li, Mr. Heinz-Peter Mang, Mr. Shikun Cheng, Mr. Guy Kabengele – all University of Science and Technology Beijing

**December 2011**

## TABLE OF CONTENTS

<b>1. GENERAL INFORMATION ON THE PROJECT .....</b>	<b>1</b>
<b>1.1 The benefits of the project.....</b>	<b>2</b>
<b>1.2 Overview on mason training program .....</b>	<b>3</b>
<b>2 BIOGAS ANAEROBIC DIGESTION PROCESS .....</b>	<b>5</b>
<b>2.1 How biogas is generated? .....</b>	<b>5</b>
<b>2.2 Substrate .....</b>	<b>5</b>
<b>2.3 Biogas composition.....</b>	<b>7</b>
4.2.1 <i>Methane.....</i>	<i>7</i>
4.2.2 <i>Carbon dioxide (CO<sub>2</sub>).....</i>	<i>8</i>
4.2.3 <i>Hydrogen sulphide (H<sub>2</sub>S).....</i>	<i>8</i>
<b>2.4 Biogas characteristics.....</b>	<b>9</b>
2.4.1 <i>Density .....</i>	<i>9</i>
2.4.2 <i>Density comparison to air.....</i>	<i>9</i>
2.4.3 <i>Heat value .....</i>	<i>9</i>
<b>2.5 Terminologies defined in the sectorial standard 10TCN 97 – 2006.....</b>	<b>10</b>
<b>2.6 Wastewater from livestock production .....</b>	<b>10</b>
2.6.1 <i>Characteristics and volume .....</i>	<i>10</i>
2.6.2 <i>Viet Nam industrial wastewater discharge standards .....</i>	<i>11</i>
<b>2.7 Benefits of biogas technology .....</b>	<b>12</b>
2.7.1 <i>Energy benefits.....</i>	<i>12</i>
2.7.2 <i>Benefit for fertilization.....</i>	<i>12</i>
2.7.3 <i>Reduction of the pathogenic capacity a. disease transmission.....</i>	<i>13</i>
2.7.4 <i>Environmental benefit.....</i>	<i>13</i>
2.7.5 <i>Social benefit.....</i>	<i>13</i>
<b>3. HOUSEHOLDER BIOGAS PLANT TYPES.....</b>	<b>15</b>
<b>3.1. Balloon plants .....</b>	<b>16</b>
<b>3.2 Fixed Dome Plants.....</b>	<b>16</b>

3.3	<b>Floating Drum Plants</b> .....	15
4.	<b>INTRODUCTION OF A PLUG-FLOW BIOGAS SYSTEM</b> .....	18
4.1	<b>Classification of medium-scale biogas plants</b> .....	18
4.2	<b>Characteristics and structures of plug-flow biogas plants</b> .....	19
4.2.1	<i>The plug-flow biogas system characteristics</i> .....	19
4.2.2	<i>Compositions of an plug-flow biogas system</i> .....	20
4.3	<b>Operation of the plug-flow biogas system</b> .....	21
4.4	<b>Dimensions for plug-flow biogas plant design</b> .....	22
5.	<b>CONSTRUCTION</b> .....	25
5.1	<b>Construction site preparation</b> .....	25
5.2	<b>Materials for construction and material requirements</b> .....	25
5.3	<b>Defining the levels for biogas components and reference line for construction</b> .....	27
5.4	<b>Excavation</b> .....	27
5.4.1	<i>Excavation tools</i> .....	27
5.4.2	<i>Digging</i> .....	27
5.5	<b>Bottom concrete</b> .....	29
5.5.1	<i>Foundation consolidation</i> .....	29
5.5.2	<i>Casting the concrete foundation</i> .....	30
5.5.3	<i>Concrete curing</i> .....	30
5.6	<b>Digester wall construction</b> .....	31
5.7	<b>Formwork and casting the concrete for the covers</b> .....	31
5.8	<b>Plastering work</b> .....	31
5.9	<b>Installing the inlet and outlet pipes</b> .....	32
5.10	<b>Backfilling</b> .....	32
5.11	<b>Safety in construction</b> .....	33
5.12	<b>Water-tightness checking</b> .....	33
5.12.1	<i>By observation from the inside</i> .....	33
5.12.2	<i>By using water</i> .....	33

<b>5.13 Gas-tightness checking.....</b>	<b>34</b>
5.13.1 <i>Checking the gas tightness of the digester.....</i>	34
5.13.2 <i>Checking the gas tightness of the gas pipe .....</i>	34
<b>6. OPERATION AND MAINTENANCE OF THE BIOGAS PLANT .....</b>	<b>35</b>
<b>6.1 Put the biogas plant into operation .....</b>	<b>35</b>
6.1.1 <i>Start-up of the biogas process.....</i>	35
6.1.2 <i>Cautions for Start-up Operation.....</i>	35
6.1.3 <i>Preparing feedstock .....</i>	36
6.1.3.1 <i>Feedstock is animal dung.....</i>	36
6.1.3.2 <i>Feedstock are plants .....</i>	36
6.1.4 <i>Dilution and mixing feedstock .....</i>	36
6.1.5 <i>Filling feedstock into the digester.....</i>	37
6.1.6 <i>Quality of new plant's biogas production.....</i>	37
<b>6.2 Daily biogas plant operation .....</b>	<b>38</b>
6.2.1 <i>Feedstock filling.....</i>	38
6.1.2.1 <i>General requirements .....</i>	38
6.1.2.2 <i>Daily filling feedstock amount .....</i>	39
6.1.2.3 <i>Impurities and toxic substances must be avoided.....</i>	39
6.2.2 <i>Monitoring operation of biogas plant via biogas pressure .....</i>	39
<b>6.3 Maintenance of biogas plants.....</b>	<b>40</b>
<b>6.4 Safety in biogas use .....</b>	<b>40</b>
6.4.1 <i>Preventing explosion.....</i>	40
6.4.2 <i>Preventing asphyxiation .....</i>	41
6.4.3 <i>Safety issues associated with repair and maintenance .....</i>	41
<b>6.5 Common troubles and remedies .....</b>	<b>42</b>
<b>7. BIOGAS APPLIANCES .....</b>	<b>44</b>
<b>7.1 Cleaning biogas.....</b>	<b>44</b>
<b>7.2 Biogas filtration methods.....</b>	<b>44</b>
7.2.1 <i>Biological method .....</i>	44

7.2.2	<i>Chemical methods</i> .....	44
<b>7.3</b>	<b>Generators fueled by biogas</b> .....	<b>46</b>
7.2.3	<i>Modification of petrol engines</i> .....	46
7.2.4	<i>Modification of diesel engines</i> .....	47
7.2.5	<i>Installation and operation of biogas generators</i> .....	47
7.2.6	<i>Operation of biogas generators</i> .....	48
7.2.7	<i>Maintenance of generators</i> .....	50
7.2.8	<i>Trouble shooting and remedies</i> .....	50
<b>7.4</b>	<b>Biogas water boilers</b> .....	<b>51</b>
7.4.1	<i>Classification of biogas water boilers</i> .....	51
7.4.2	<i>Structure and operation</i> .....	52
<b>7.5</b>	<b>Biogas heated chick incubator</b> .....	<b>52</b>
7.5.1	<i>Components of the incubator</i> .....	52
7.5.2	<i>Heating element</i> .....	53
7.5.3	<i>Temperature regulator</i> .....	53
7.5.4	<i>Air exchange system</i> .....	53
<b>7.6</b>	<b>Tea drying by biogas</b> .....	<b>54</b>
<b>8.</b>	<b>BIOSLURRY UTILIZATION</b> .....	<b>55</b>
<b>8.1</b>	<b>Nutrients and characteristics of bioslurry</b> .....	<b>55</b>
<b>8.2</b>	<b>Using bioslurry as fertilizer</b> .....	<b>56</b>
<b>8.3</b>	<b>Using bioslurry for fish production</b> .....	<b>57</b>
8.3.1	<i>Raising fish in ponds</i> .....	57
8.3.2	<i>Raising fish in rice fields</i> .....	58
<b>8.4</b>	<b>Production of compost and biofertilizer from agricultural waste and bioslurry</b> .....	<b>58</b>
8.4.1	<i>Production of compost</i> .....	58
8.4.2	<i>Production of micro-organic fertilizer</i> .....	59
8.4.3	<i>Methodology</i> .....	59
<b>8.5</b>	<b>Use of compost and micro-organic fertilizer</b> .....	<b>59</b>

---

<b>9. BIOGAS TECHNOLOGY AND THE CLEAN DEVELOPMENT MECHANISM (CDM)</b> .....	<b>62</b>
<b>9.1 Kyoto Protocol and Clean Development Mechanism</b> .....	<b>62</b>
9.1.1 <i>The United Nations Framework Convention on Climate Change (UNFCCC)</i> .....	62
9.1.2 <i>Kyoto Protocol (KP)</i> .....	62
9.1.3 <i>Clean Development Mechanism (CDM) of KP</i> .....	62
<b>9.2 Biogas technology and CDM</b> .....	<b>63</b>
9.2.1 <i>Contribution of biogas technology in reduction of GHG emission</i> .....	63
9.2.2 <i>CDM projects for biogas</i> .....	64
<b>10. QUALITY MANAGEMENT FOR MEDIUM-SCALE BIOGAS PLANTS</b>	<b>65</b>
<b>10.1 General requirements</b> .....	<b>65</b>
<b>10.2 Technical staff of the project</b> .....	<b>65</b>
<b>10.3 Technical supervisor in the field</b> .....	<b>66</b>
<b>10.4 Mason teams</b> .....	<b>67</b>
<b>10.5 Biogas plant owner</b> .....	<b>67</b>

## 1. GENERAL INFORMATION ON THE PROJECT

Medium and large scale livestock production (swine – dairy – poultry) is the fastest growing segment of the animal husbandry sector in Viet Nam. At this scale, the farms produce a significant volume of waste that cause environmental pollution and generate greenhouse gases (GHG) emissions to the air.

Building upon the success of the Netherlands Development Organisation - SNV and the Viet Nam Biogas Program, this project will promote and introduce the model of medium-scale biogas plants (50-500m<sup>3</sup>), that will help treat livestock waste from medium size farms, whilst providing biogas for electricity generation. The project also supports reduction of GHG emissions from these farms.

The project is financed by Ministry for Foreign Affairs of Finland and the Nordic Development Fund in order to develop and stimulate a sustainable market for medium-scale biogas plants; to provide the users with a sustainable energy source and other benefits such as decentralized power production, saving cooking time; reducing dependence on fossil fuels; and ensuring better environment for human health through more effective manure and wastewater management.

The project is implemented by the local and international partners, including public organizations and private companies such as The Netherlands Development Organization (SNV), Stockholm Environment Institute (SEI), Institute of Energy (IE), and Global Energy Consultant & Investment (GECI) with the objective to stimulate and develop a medium-scale biogas plant market in Viet Nam. Through SEI, the Centre of Sustainable Environmental Sanitation at the University of Science and Technology Beijing is subcontracted for design consultancy and technical support. To achieve the objectives, the project includes the activities such as introduction and construction of demonstration models and piloting 10 medium-scale plug-flow biogas plants in 10 different farm sites.

The project is implemented in 2 years from 2011 – 2012 in some provinces in the North of Viet Nam. The roles of stakeholders are as in the figure below.

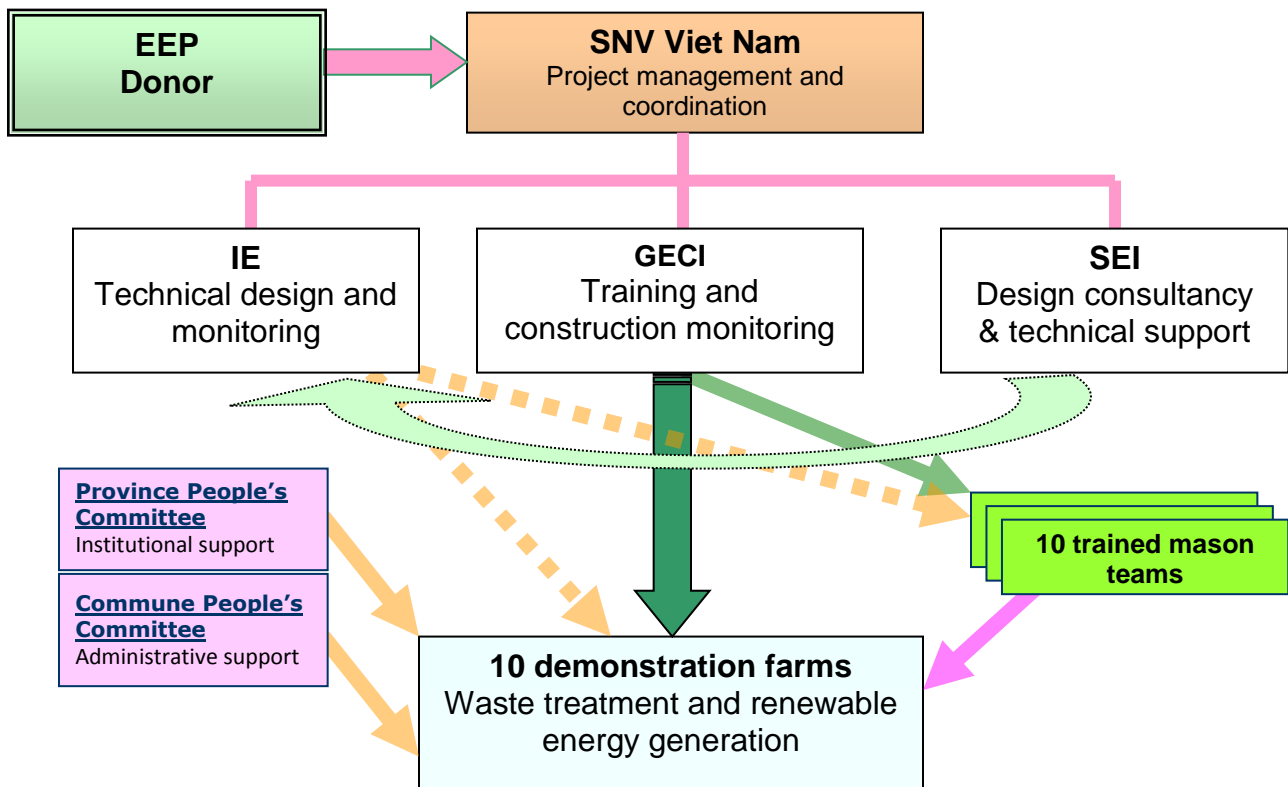

*Figure 1 – Structure of the project*

## 1.1 The benefits of the project

The project will provide financial and technical support in construction of 10 demonstration models in 10 chosen farms.

In order to be selected by the project, the farms need to meet the following criteria:

- The livestock farms apply industrial or semi-industrial animal husbandry methods with a stable number of 500 – 1,500 pigs and manure volume ranged from 1,000 – 4,000 kg/day;
- Having appropriate space to build a medium-scale biogas plant and the related post-treatment system;
- Having demand for biogas technology benefits on the farm to meet the following targets: waste treatment, energy generation (thermal and electrical) and bio fertilizer production;



- Volunteering in funding contribution to biogas plant construction and committing to fully participate in the biogas training courses to operate and maintain the biogas plants efficiently and properly under regulations;
- Having capacity and human resources to operate and maintain the digester and associated equipment, such as generator, pump-engines and other thermal applications (heating, cooking) as required by the project.

The project provides financial support not only for construction of 10 demonstration models but also for mason and user training courses in order to ensure high quality and smooth operation of the biogas plants in the project framework.

## 1.2 Overview on mason training program

***The objectives of mason training:*** To achieve the objectives set out by the project and to ensure high quality utilization of the biogas plants supported by the project., The stakeholders and end users ideally should have relevant knowledge and understanding about biogas production process, operational principles and related benefits from biogas application. When the project ends, new job opportunities will be generated, so it is necessary to provide the mason teams with quality training courses on relevant skills and operational techniques of this new biogas model. The masons after attending the training courses will be able to read technical drawings on plug-flow medium scale biogas plants and will be equipped with the relevant technical knowledge in construction. They will develop their own careers based on the knowledge and lessons learnt. Thus, mason training is not only one of the main project activities but also a firm basis for their success in the future.

***Mason training activities:*** GECI takes the main responsibility for mason training activities. The mason training will be conducted over 3 days and the participating masons will be provided with training materials as well as other logistics support by GECI in order to create good conditions for masons to acquire the knowledge provided by the trainers. The masons are also requested to fully participate in the training and are encouraged to give open feedback to clarify any problems during

the training. This course will be a good opportunity for the participants as well as for the trainers to exchange knowledge and learning from one another.

The primary objective of the training is to ensure masons fully understand the plug-flow biogas system, have the necessary skills to read technical drawings and to acquire the relevant knowledge to build high quality medium-scale biogas plants. It is also expected that the trained masons will be active in disseminating and building small-scale biogas plants for Viet Nameese households in Viet Nam.

### ***Training course contents and agenda:***

#### ***Theoretical***

- Unit 1. Introduction on the project and training programme
- Unit 2. Medium-scale biogas technology
- Unit 3. Construction of medium-scale biogas plants
- Unit 4. Applications of biogas from medium-scale plants
- Unit 5. Bioslurry applications
- Unit 6. Medium-scale biogas technology and CDM issues
- Unit 7. Operation and maintenance of medium-scale biogas plants
- Unit 8. Quality control for medium-scale biogas plants
- Unit 9. Process optimization

#### ***Practical***

1. Biogas plant construction method: Define biogas plant component area and levels; how to get the reference line in construction; how to determine center point and build biogas dome; and set up biogas distribution and use system.
2. Testing and acceptance.
3. Commissioning and Start-up operation.

## 2 BIOGAS ANAEROBIC DIGESTION PROCESS<sup>1</sup>

### 2.1 How biogas is generated?

Biogas originates from bacteria in the process of bio-degradation of organic material under anaerobic conditions. Methanogens (methane producing bacteria) are the last link in the decomposition chain of micro-organisms compound to generate biogas. Biogas is regarded as a source of renewable energy.

Decomposition of organic matter in anaerobic environment is composed of four main phases (hydrolysis, acidification, acetic acid formation, methane formation) as show in *Figure 2.1*.

### 2.2 Substrate

In general, anaerobic digestion process of manure is not long and biogas production depends on manure type and many other factors. Actual biogas production of the feedstock is shown in *Table 2.1*.

The anaerobic digestion is very susceptible to disturbances; the biogas production can be affected by many factors. The most important of all is to ensure the environment inside the digester is anaerobic; meaning it must be airtight and sealed from the outside environment. Other important factors include:

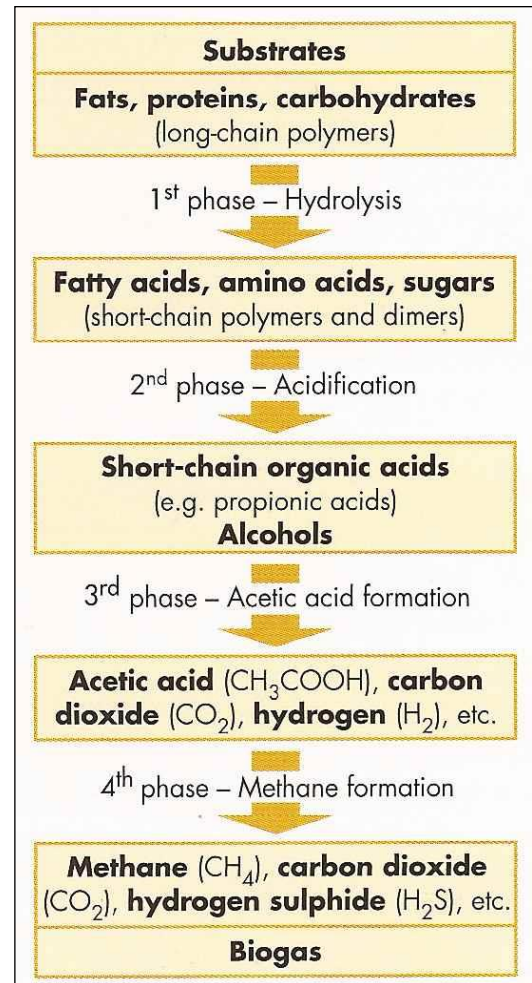

**Figure 2.1 - Anaerobic digestion process to generate biogas**

<sup>1</sup> Information from Biogas Digest volumes I,II and III (GTZ, ISAT, 1990)

- Temperature: For householder plant without heating system, the processes take place in psychrophilic zone (15-25°C). Lower temperature like in cold period slow down bacteria production;
- pH: In the digester, the optimal range is the neutral one from 6.8 - 7.4;
- Dry matter of feedstock:<8% to ensure good flow behavior in the digester;
- C/N ration: carbon to nitrogen ratio should be about 30/1;
- Retention time: feedstock should be retained in digester about 40-45 days in winter in the North and 30-35 days in the South;
- Inhibitors: Non-organic soaps, detergents, antibiotics and other non-biodegradable chemicals reduce biogas production;
- Stones, sediment, wood, etc, accumulate and reduce digester efficiency.

Livestock	Amount of manure daily (kg/head)	Dry matter content (%)	Carbon/nitrogen (C/N) ratio <sup>2</sup>	Gas yield of the feedstock daily (litre/kg/day)
Cow	15 - 20	18 - 20	24 - 25	15 - 32
Buffalo	18 - 25	16 - 18	24 - 25	15 - 32
Pig	1.2 – 4.0	24 - 33	12 - 13	40 - 60
Poultry	0.02 – 0.05	25 - 50	5 - 15	50 - 60
Human	0.18 – 0.34	20 - 34	2.9 - 10	60 - 70

***Table 2.1 - Characteristics and yield of biogas in Viet Nam***

Feedstock for biogas anaerobic digestion can be animal manure, human waste (i.e. sewage) and other organic matter. However, the most common feedstock in rural areas of Viet Nam is animal manure.

The amount of waste matter per head depends on body weight and nutritional regimen. This amount is calculated as in the *Table 2.2*.

<sup>2</sup> depending of urine separation efficiency

	Body weight (kg)	Volume of waste by percentage (%) of the body weight		Volume of fresh manure (kg/day)
		Dung	Urine	
Cow	135 – 800	3-5	4 – 5	8
Milk cow	300 – 500	3-5	4 – 5	8
Buffalo	300 – 500	3-5	4 – 5	8
Pig	30 – 75	0.5 - 2	1 - 3	2
Chicken	1.5 – 2.0	0.05		0.05
Human	60 - 80	0.3 – 0.5	0.5 - 1	0.5

**Table 2.2 - Amounts of human and animal wastes discharged per day**

## 2.3 Biogas composition

Biogas is a mixture of many gases. The composition of biogas varies depending on raw materials and conditions for decomposition such as temperature, pH value, water level, and different phases of decomposition, etc. The typical composition of biogas is shown in *Table 2.3*.

Types of gas	Ratio (%)
Methane -- CH <sub>4</sub>	50 – 70
Carbon dioxide - CO <sub>2</sub>	25 – 45
Water – H <sub>2</sub> O	2 – 7
Nitrogen - N <sub>2</sub>	<2
Oxygen - O <sub>2</sub>	<2
Ammonia - NH <sub>3</sub>	<1
Hydro Sulfide - H <sub>2</sub> S	<1

**Table 2.3 The composition of biogas**

### 2.3.1 Methane

The main component of biogas is methane (CH<sub>4</sub>). Methane is a gas without color and odour, is lighter than air (about half the weight of air). Methane is liquefied at a temperature of minus 161.5 degree Celsius at atmospheric pressure. Therefore, liquefying methane consumes much energy, which is the reason why methane, natural gas and biogas are seldom liquefied.

When burning, biogas flame is faint blue and releases heat according to the following reaction:

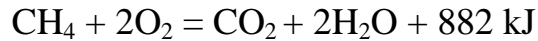

Net heat value (i.e. the number of kJ liberated by the complete combustion of one cubic meter of fuel) of methane is 35,906 kJ per cubic meter or 8,576 kcal per cubic meter.

### 2.3.2 *Carbon dioxide (CO<sub>2</sub>)*

The second main component of biogas is carbon dioxide (CO<sub>2</sub>). It is a colorless non-flammable gas. It is 1.5 times heavier than air, does not burn and cannot sustain life. The high content of carbon dioxide in biogas will reduce quality of biogas. Usually, during initial days of operation, the carbon dioxide component in biogas is higher than methane, so the stove does not burn and it is often discharged until methane level increases and becomes stable.

### 2.3.3 *Hydrogen sulfide (H<sub>2</sub>S)*

Apart from major components of biogas mentioned above, there are small amounts of other gases including hydrogen sulfide (H<sub>2</sub>S). Hydrogen sulfide is a colorless gas that has a foul odor (rotten egg smell), so that biogas can be easily realized. The concentration of H<sub>2</sub>S in the biogas produced by human manure and poultry dung is usually higher than other feedstock, so the biogas plants with this kind of feedstock have bad smell. However, H<sub>2</sub>S is a reductant and flammable gas, and the smell will disappear when combusting. It is a toxic gas, therefore, inhaling this gas over a long period can cause headache, vomiting and unable to distinguish different odors.

Combustion reaction of H<sub>2</sub>S in the presence of oxygen produces sulphur dioxide (toxic gas) and water:

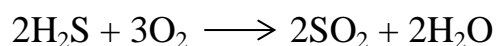



H<sub>2</sub>S dissolved in water will create acid that corrodes metal parts of the utilities. Therefore, this biogas must be filtered before using to ensure the lifetime of machines and gas utilities.

## 2.4 Biogas characteristics

Biogas is usually fully saturated with water vapor. This vapor will be condensed into water in gas pipelines under low temperature, thus it needs to be removed. This is usually achieved using a water trap.

Different chemical compositions of biogas have different characteristics. We take as reference biogas with methane content of 60% and CO<sub>2</sub> to make comparison with other gases such as air.

### 2.4.1 Density

Density of a gas is equal to the gas volume (m<sup>3</sup>) under standard temperature and pressure, 0°C and 1 atm = 760 mm Hg.

Reference biogas has a density of 1.2196 kg/m<sup>3</sup>

### 2.4.2 Density comparison to air

At the same temperature and pressure, reference biogas has density comparison to air of 0.95 (1.2196/1.29 = 0.95). Thus biogas is slightly lighter than air.

### 2.4.3 Heat value

The heat value of a gas is the heat that is released when a unit volume of gas is combusted.

Biogas with a 60% of methane content and 40% of CO<sub>2</sub> has a heating value of:

$$35.9 \text{ MJ/m}^3 \times 0.6 = 21.543 \text{ MJ/m}^3$$

For further calculations, 21.5 MJ/m<sup>3</sup> will be used.

## 2.5 Terminologies defined in the sectorial standard 10TCN 97 – 2006

*Biogas plant:* is the whole system consisting of substrate feed-in tank, digester tank, compensation tank, bioslurry tank, pipe, biogas device, gas conveyance and gas using appliances,.

*Digester:* is the main component of biogas plant for retaining the feedstock and ensuring the appropriate conditions for the anaerobic digestion process to take place smoothly.

*Compensation tank:* is a component of biogas plant to do the task of creating gas pressure by retaining effluent coming out from digester when gas is produced.

*Digestive fluid:* is fluid environment in digester where digestion process happens.

*Bioslurry:* a by-product of solid and liquid form which is produced from decomposition process of substance. Bioslurry comprises three elements called biogas digested effluent, solid residue and scum.

- Biogas digested effluent: liquid flows from digester to compensation tank.
- Solid residue: solid lies on the bottom of digester.
- Scum: solid floats on the surface of the fluid in digester.

## 2.6 Wastewater from livestock production

### 2.6.1 *Characteristics and volume*

Livestock wastewater is very rich in nutrients and microorganisms and can be collected from pigsty cleaning and livestock waste. The factors that cause pollution of livestock wastewater and food industry wastewater are mainly suspended solids, organic matters (BOD<sub>5</sub> and COD) and pathogenic microorganisms.

The volume and composition of livestock wastewater depends on the type and size of livestock production, pigsty cleaning method and animal feeds. Typical composition values are presented in *Table 2.4* below:



Composition	Concentration			TCVN 5945 – 2005*		
	High	Medium	Low	A	B	C
Suspended solids (g/l)	80	55	30	0.05	0.1	0.2
BOD <sub>5</sub> (20°C) (mg/l)	30	20	10	0.03	0.05	0.1
COD (g/l)	60	42	25	0.5	0.08	0.4
Total nitrogen (g/l)	5	3,5	2	0.15	0.3	0.6
NH <sub>4</sub> <sup>+</sup> (g/l)	4	3,5	3	0.005	0.01	0.015
Chlorine	0.8	0.8	0.8	0.5	0.6	1
pH	8	7.5	7	6-9	5.5-9	5-9

**Table 2.4: Average concentration of pollutants in livestock wastewater**

Note: - COD: Chemical Oxygen Demand  
- BOD: Biochemical Oxygen Demand

### 2.6.2 Viet Nam industrial wastewater discharge standards

Viet Nam Standard TCVN 5945-2005 stipulated limit values of concentrations of substances in wastewater of manufacturing, processing, trading facilities and services referred to as industrial wastewater.

As abstract, it can be stated for industrial wastewater having the values of parameters and concentrations of the components equals to or less than the values specified in:

- column A, may be discharged into the water bodies to be used as sources of living water supply.
- column B, but not exceeding values specified in column C is only allowed to flow into specified place.
- column C, shall not be discharged into the environment.

*According to above standard, the indicators of Chemical Oxygen Demand (COD), Biochemical Oxygen Demand (BOD), and Suspended Solid (SS) of wastewater after treatment at the farm must meet the following criteria:*

$$\text{BOD}_5 = 50\text{mg/l}$$

$$\text{COD} = 80\text{mg/l}$$

$$\text{SS} = 100\text{mg/l}$$

## **2.7 Benefits of biogas technology**

### **2.7.1 Energy benefits**

Biogas energy value is 5-7.5 kWh/m<sup>3</sup> (depending on methane content efficiency of and the burners or appliances) but average value is 6 kWh/m<sup>3</sup> or 21.5 MJ/m<sup>3</sup>

1 m<sup>3</sup> Biogas is equivalent to:

- Diesel, Kerosene (approx. 12 kWh/kg)                      0.5 kg
- Wood (approx. 4.5 kWh/kg)                                      1.3 kg
- Cow dung (approx. 5 kWh/kg dry matter)                      1.2 kg
- Plant residues (approx. 4.5 kWh/kg d.m.)                      1.3 kg
- Hard coal (approx. 8.5 kWh/kg)                                      0.7 kg
- Natural gas (approx. 5.3 kWh/m<sup>3</sup>)                                      1.1 m<sup>3</sup>
- Propane (approx. 25 kWh/m<sup>3</sup>)                                      0.24 m<sup>3</sup>

The biogas generated from small sized units is generally used for cooking and lighting purposes. Medium and large units and/or communal units produce this gas in larger quantities and can be used to power engines and generators for mechanical work or power generation.

### **2.7.2 Benefit for fertilization**

Fertilizer is very important, especially in a country where the farmers do not have the resources to buy chemical fertilizers frequently. It has been calculated through lab tests that the fertilizer which comes from a biogas plant contains 3 times more nitrogen than the compost made through open air digestion.

Bio-fertilizers also secrete growth promoting substances like vitamins, amino acids and anti-fungal chemicals, as well as improve seed germination and root growth. Bio-fertilizers, thereby also aid in the better establishment of plants. and has good effect on soil improvement, erosion resistance, humis content increase etc, making it especially good for crops

### ***2.7.3 Reduction of the pathogenic capacity a. disease transmission***

The processing of animal and human excrement in biogas systems obviously improves sanitary conditions for the plant owners, their families and the entire village community. The initial pathogenic capacity of the starting materials is greatly reduced by the fermentation process. In addition, noxious odors are avoided, because the decomposed slurry stored in such pits is odorless.

Since well-fermented and post-treated biogas slurry does not attract flies or other vermin, the vectors for contagious diseases, for humans and animals alike, are reduced.

### ***2.7.4 Environmental benefit***

Well-functioning biogas plants can replace the consumption of firewood or charcoal of an individual household by biogas. In macro-economic cost-benefit analyses the amount of firewood or charcoal saved is often directly translated into hectares of deforestation.

For national or regional planning, however, the reduction of deforestation and consequent soil erosion is one of the main arguments to allocate public funds for the dissemination of biogas technology.

Also, biogas can helps to reduce GHG emissions if the produce biogas amount is combusted by CHP or gas flare instead of being release to air as methane affect 21 times more than carbon dioxide the ozon layer.

### ***2.7.5 Social benefit***

The use of biogas for cooking improves the living conditions of the farmers in rural areas; particularly women who are usually responsible for cooking and fuel collection.

Cultural and educational sectors would also promote by using the biogas for lighting and improve the living conditions with household appliances. Biogas lighting makes it possible to engage in activities at night such as reading or attending evening courses instead of using kerosene lamp.

### 3. HOUSEHOLD BIOGAS PLANT TYPES

There are many kinds of household biogas plant types worldwide but most of them based on three main householder biogas plants types (see figure 3.1).

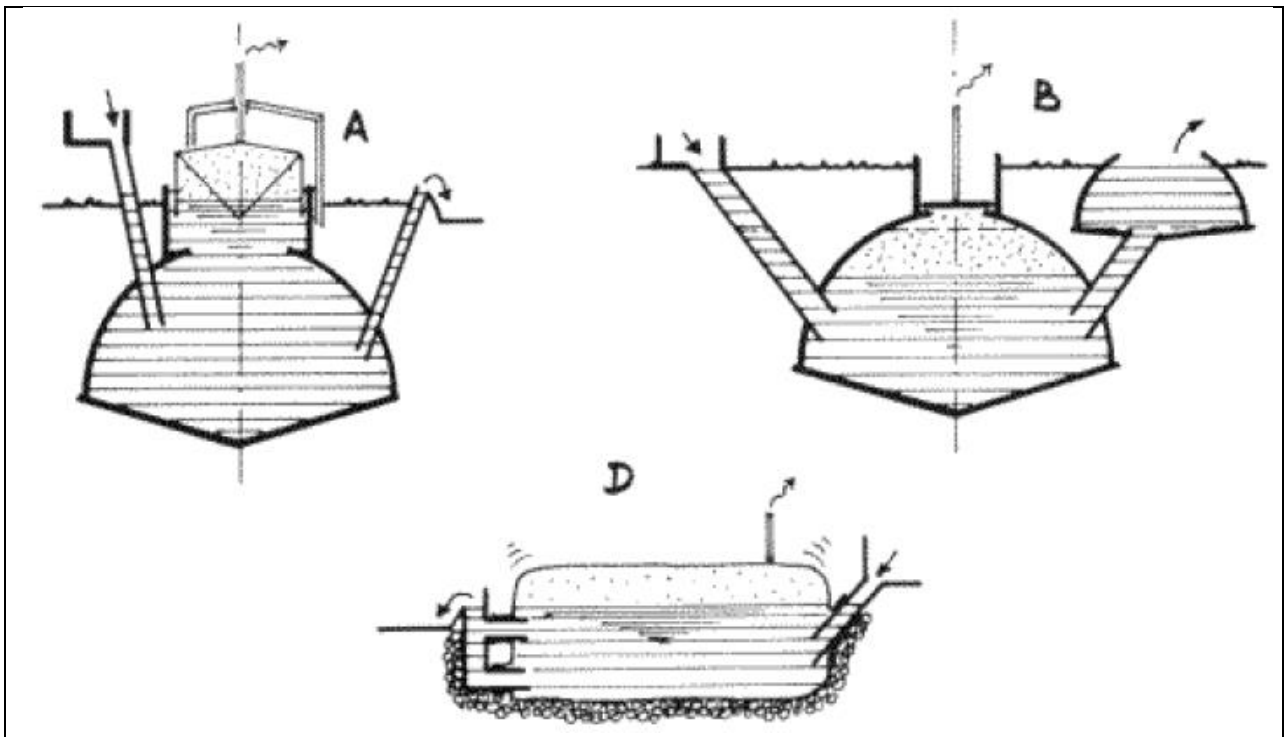

**Figure 3.1** Most common household biogas plant – A) floating drum plants; B) fixed dome plants; and D) balloon plants

#### 3.1 Floating Drum Plants

Floating-drum plants consist of an underground digester and a moving gas-holder. The gasholder floats either directly on the fermentation slurry or in a water jacket of its own. The gas is collected in the gas drum, which rises or moves down, according to the amount of gas stored. The gas drum is prevented from tilting by a guiding frame. If the drum floats in a water jacket, it cannot get stuck, even in substrate with high solid content.

Advantages are the simple, easily understood operation - the volume of stored gas is directly visible. The gas pressure is constant, determined by the weight of the gas holder.

The construction is relatively easy, construction mistakes do not lead to major problems in operation and gas yield.

Disadvantages are high material costs of the steel drum, the susceptibility of steel parts to corrosion. Because of this, floating drum plants have a shorter life span than fixed-dome plants and regular maintenance costs for the painting of the drum.

### **3.2 Fixed Dome Plants**

The fixed-dome plant consists of a digester with a fixed, non-movable gas holder, which sits on top of the digester. When gas production starts, the slurry is displaced into the compensation tank. Gas pressure increases with the volume of gas stored and the height difference between the slurry level in the digester and the slurry level in the compensation tank.

Advantages are the relatively low construction costs, the absence of moving parts and rusting steel parts. If well-constructed, fixed dome plants have a long life span. The underground construction saves space and protects the digester from temperature changes.

Disadvantages are mainly the frequent problems with the gas-tightness of the brickwork gasholder (a small crack in the upper brickwork can cause heavy losses of biogas). Fixed-dome plants are, therefore, recommended only where construction can be supervised by experienced biogas technicians. The gas pressure fluctuates substantially depending on the volume of the stored gas. Even though the underground construction buffers temperature extremes, digester temperatures are generally low.

### **3.1. Balloon plants**

The balloon plant consists of a digester bag (e.g. PVC) in the upper part of which the gas is stored. The inlet and outlet are attached directly to the plastic skin of the balloon. The gas pressure is achieved through the elasticity of the balloon and by added weights placed on the balloon.

Advantages are low cost, ease of transportation, low construction sophistication, high digester temperatures, uncomplicated cleaning, emptying and maintenance.

Disadvantages can be the relatively short life span, high susceptibility to damage, and little creation of local employment and, therefore, limited self-help potential.

A variation of the balloon plant is the channel-type digester, which is usually covered with plastic sheeting and a sunshade. Balloon plants can be recommended wherever the balloon skin is not likely to be damaged and where the temperature is even and high.

## 4. INTRODUCTION OF A PLUG-FLOW BIOGAS SYSTEM

### 4.1 Classification of medium-scale biogas plants

A medium-scale biogas plant is a biogas system to treat livestock waste for a medium-scale farm or a medium-scale livestock production cluster.

There are many ways to classify medium-scale biogas plants depending on the standards such as volume, temperature of digestion, types of flow, or phase separation technique. For simplicity, the classification will depend on the volume of the digester. According to the sector standard 10 TCN 97 ÷ 102:2006 issued by MARD, the small-scale biogas plants are the ones with the volume  $\leq 40\text{m}^3$ , which is equivalent to household scale with less than 100 pigs. Therefore, the classification can be referred to some former Chinese classifications (valid before 2012) or the proposals of some well-known organization as in the *Table 4.1*.

Origin	Scale	Total volume ( $\text{m}^3$ )	Tank volume ( $\text{m}^3$ )
China	Large	$\geq 1000$	$\geq 500$
	Medium	100 - 1000	100 - 500
	Small (Household)	$< 100$	$< 100$
Biogas technology centre (BTC)	Large	$\geq 100$	$\geq 100$
	Small (Household)	$< 100$	$< 100$
Biogas Component of QSEAP project	Large	$> 1000$	
	Medium	$> 50 \leq 1000$	
	Small (Household)	$\leq 50$	

***Table 4.1 – Biogas plant classification***

Medium-scale biogas plants are suitable for livestock waste treatment at medium-size farms due to the following reasons:

- 1) To treat livestock waste for environmental protection;



- 2) To produce renewable energy (biogas) to serve daily activities and production at the farms;
- 3) To sustainably and efficiently use nutrients from bioslurry

## 4.2 Characteristics and structures of plug-flow biogas plants

### 2.3.1 *The plug-flow biogas system characteristics*

- This is a wastewater treatment system designed based on the operational principle of the simple fixed dome biogas plant with continuous and automatic filling principle. The operation of the system is as shown below.

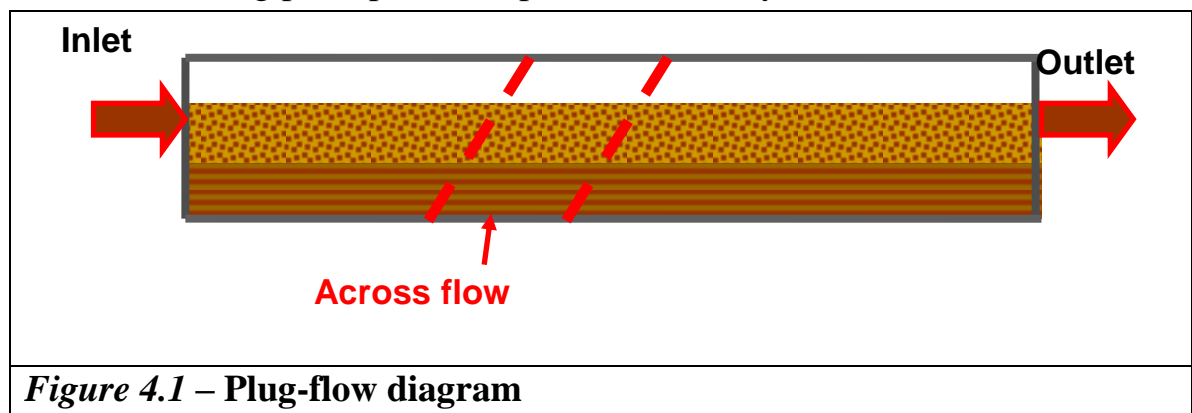

**Figure 4.1 – Plug-flow diagram**

- Daily volume loaded into the system ranges from 0.6 - 4m<sup>3</sup> corresponding to a digester volume of 50 - 500 m<sup>3</sup>. Dry matter content loaded into the tank should be 6-10%.
- The biogas plant is built of bricks and cement, and totally or half underground, so it should be durable, consume no energy, provide simple operation and maintenance.
- This system, however, is not applicable to cases of excessive fluctuation of feedstock, especially in absence of ability to control the dilution ratio of input materials.

### 2.3.2 Compositions of an plug-flow biogas system

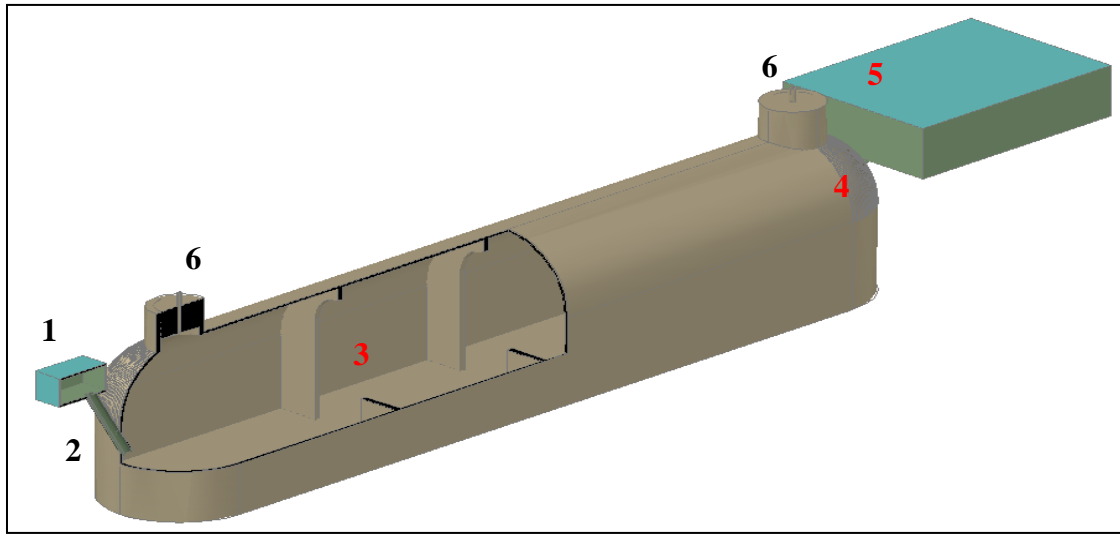

**Figure 4.2 Composition of a plug flow biogas plant**

A plug flow biogas plant consists of 6 main components:

- |                      |                |
|----------------------|----------------|
| 1) Mixing tank       | 2) Inlet pipe  |
| 3) Digester tank     | 4) Outlet pipe |
| 5) Compensation tank | 6) Gas pipe    |
- This is a medium-scale biogas system with the compensation tank of large volume ( $> 20 \text{ m}^3$ ), thus, pressure safety plays an important role. Also, there is no gas escape from the digester in case of high pressure. Therefore, an automatic outlet valve is fitted before the main valve, so that when the pressure is too high, this valve will automatically release the gas to ensure the safety of the digester.
  - To avoid high pressures and operational & design gas leakages, in larger designs than  $50\text{-}100 \text{ m}^3$ , the compensation tank is replaced by flexible gas storages (PVC or HDPE).
  - If the gas pipe goes underground, a valve is also fitted after the main valve for releasing the condensate.

### 4.3 Operation of the plug-flow biogas system

Like a fixed dome biogas plants, a plug-flow biogas plant works in two phases:

- **Gas accumulation stage:** At the first stage, the biogas pressure in the digester is equal to 0 ( $P = 0$ ). At this time, the surface of the slurry in the digester is at the "zero level". Gas generated will create pressure on the surface of slurry and push slurry into compensation tank. As more gas is generated, the higher the pressure becomes and consequently, more slurry is pushed into the compensation tank. Finally, the slurry in compensation tank rises to the highest level called "overflow level" and slurry inside digester lowers to the lowest level. At this time, the gas pressure reaches the maximum value  $P_{max}$ .

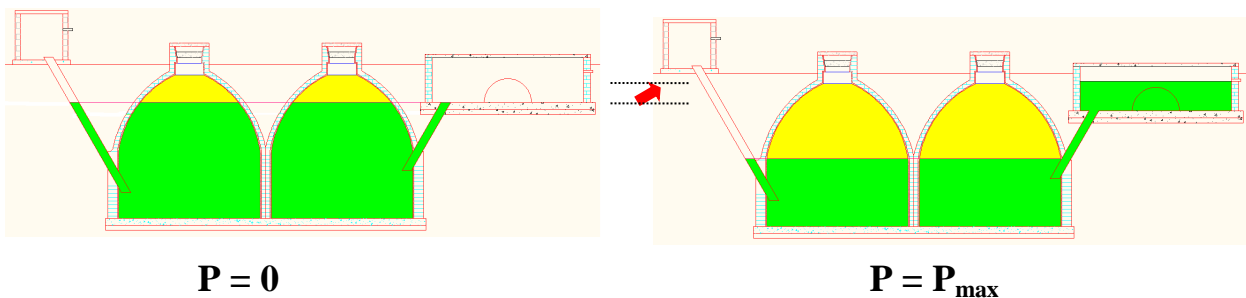

*Figure 4.3 – Gas accumulation stage of the plug-flow biogas plan*

- **Gas consumption stage:** When gas is released for consumption, the slurry from the compensation tank flows back into the digester tank. The more gas is consumed, the lower the surface of slurry in compensation tank and the higher the level of slurry in the digester. The level of slurry in the digester will reach the "zero level" and the pressure on the surface of slurry in the digester tank returns to the initial state of the operation cycle at  $P = 0$ .

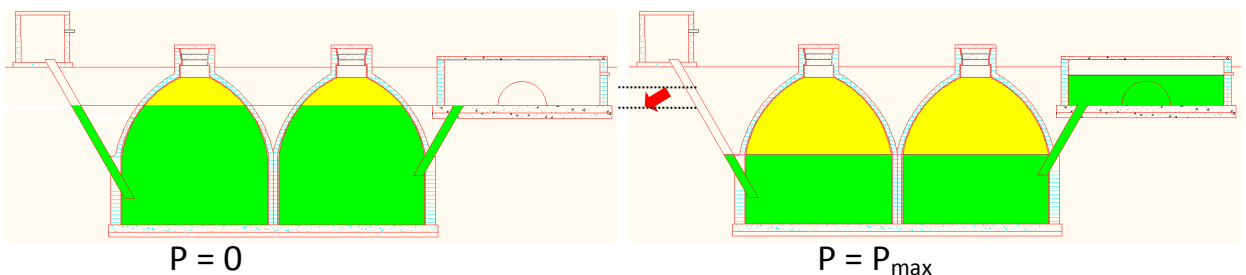

### *Figure 4.4 - Gas consumption stage of the plug-flow biogas plant*

The incorrect construction and operation of components in the household fixed-dome biogas plant can also apply in the plug-flow biogas plant. So, the following problems should be avoided when operating and constructing the biogas plant:

- **Construction notices:** The bottom of compensation tank must be equal to the “zero level” in the digester tank. The “overflow level” must be defined at least 20cm lower than the bottom of digester’s cover and also lower than the bottom elevation of mixing tank. Other parts must be located as in the technical drawing attached to the training manual.
- **During operation process:** control the dilution rate to assure its efficient operation and high gas generation; comply with the requirements on the quantity and quality of input materials and maintenance of the system.

#### **4.4 Dimensions for plug-flow biogas plant design**

Like normal fixed dome biogas plants, plug-flow biogas plants also follow basic design principles of fixed dome biogas plants as followings.

*Basic principles in the design:*

- Digestion volume of the digester is calculated as follows:

$$V_d = RT \times S_d$$

In which:  $RT$ - Retention Time (day)  
 $S_d$  – Daily supply volume –  $m^3$ /day

- Gas storage volume of the compensation tank is calculated as follows:

$$V_g = K \times G$$

In which:  $K$  – Gas storage coefficient  
 $G$  – Biogas plant capacity with the value of  $G = Md \times Y$   
( $Md$  – Daily amount of waste– kg/day)

---

$Y$  – Gas yield of the feedstock –  $m^3/m^3/day$

The size of the compensation tank and digester must be selected and carefully calculated so that the plant can put into stable operation, ensuring durability and reasonability but the construction cost is minimal (fewer materials) to obtain optimization.

The bottom of the gas pipe should also be arranged suitably so that the slurry in the tank rises to the maximum level without covering the gas pipe, which will cause blockage and damage the biogas plant. In addition, an automatic gas release valve will be fitted before the main valve, so that when the pressure in digester tank is too high, the gas will be released through this valve to ensure the safety of the digester tank during operation.

E.g.: Calculation of the parameters for the plug-flow biogas plant with a volume of  $200m^3$  is shown in Table 4.2.

Input parameters											
No. of animals	Waste volume	Feed-in amount	Dry matter in feedstock	Solid residues	HRT	Anaerobic digestion T° min	Biogas yield at 30 °C	Gas yield coefficient		Gas yield	Methane content
				tested	selected	selected	given	As diagram		Calculated	assumed
head	kg/head/day	kg/day	%	ml/l	day	°C	l/kg manure	f-HRT	f-temp.	m <sup>3</sup> /day	%
<b>800</b>	<b>2</b>	<b>3200</b>	<b>10</b>	<b>20</b>	<b>45</b>	<b>25</b>	<b>40</b>	1.09	0.9	<b>63</b>	<b>0.65</b>
Calculated values											
Methane yield	COD		Depositing cycle in the digester	Volume of residues	Volume of liquid	Total volume of digestion	Gas coefficient	Gas containing volume		Plant Volume	
assumed	calculated		Selected	calculated	calculated	calculated	selected	calculated		calculated	
%	mg/l		month	m <sup>3</sup>	m <sup>3</sup>	m <sup>3</sup>		m <sup>3</sup>		m <sup>3</sup>	
<b>80</b>	<b>3658.33</b>		<b>18</b>	<b>34.56</b>	<b>144</b>	<b>179</b>	<b>0.40</b>	<b>25</b>		<b>204</b>	

**Table 4.2 – Parameters and calculated values for the biogas plant with the volume of 200m<sup>3</sup>**

## 5. CONSTRUCTION

We assumed that environmental impact and soil analysis are done and also that all authorization procedure in relation with building a. erecting of plant are obtained according to the local procedure.

### 5.1 Construction site preparation

- Construction site must be large enough for the design and located in a place that is easy to access for feedstock collection and filling;
- There should not be big trees near the selected sites for the installation of biogas plants (at least 5 metres away) because trees roots can break the tanks. All obstructions must be removed, if possible, to avoid their influence to the construction process as well as transportation of the materials;
- Prepare a water pump in case of high groundwater level and surface water around construction area.
- Prepare clean water for cleaning, mixing concrete and mortar during construction period:
- The site must be protected by fencing so that only people with permission are allow to move to this area;
- Material storage room, staff room and accept to toilets have to be provided a.
- Re-control of the drawing according to site layout, if necessary update.



### 5.2 Materials for construction and material requirements

Like small-scale biogas plants, medium-scale biogas plants also use available local materials such as:

- Brick: solid bricks of type A or perforated bricks (diameter of small holes through the brick not above 1 centimetre) with compressive strength of 75 kG/cm<sup>2</sup> or higher;



- Sand: golden sand with maximum diameter of 3mm for joint mortar and fine sand for plaster. Sand must be clean without mud or debris, and screened carefully before mixing;
- Cement: portland cement of PC 30 grade or higher shall be used (table 5.1);
- Gravel: crushed stone and broken bricks used for concrete mixing must be clean without soil and organic pollutants. Best stone for bottom concrete is 1x2 stone. The mortar mixed is as in Table 5.2;
- Steel: for bottom concrete of the digester, compensation tank and cover plates as required in the technical drawing.

Concrete compressive strength (MPa)	Cement (kg)	Sand (m <sup>3</sup> )	Crushed stone (m <sup>3</sup> )	Clean water (litre)
150	288.025	0.505	0.913	185
200	350.550	0.481	0.900	185
250	415.125	0.455	0.887	185

**Table 5.1 – Materials for 1m<sup>3</sup> of concrete when using Portland cement of PCB.30 and crushed stones**

Compressive strength of the mortar (MPa)	Cement (kg)	Sand (m <sup>3</sup> )	Clean water (litre)
50	230	1.09	210
75	320	1.06	210

**Table 5.2 - Materials for 1m<sup>3</sup> of mortar when using Portland cement of PCB.30 and fine sand**

- Concrete has relatively high compressive strength, but much lower tensile strength. For this reason is usually reinforced with materials that are strong in tension;  
Compressive strength of 200 MPa seems to be a good compromise between price and quality but for region with big temperature difference in winter and



summer time or instable soil, special attention have to be made to choose mixing that decrease crack potentiality;

- Inlet and outlet pipelines: use plastic pipeline of uPVC under TCVN 6151:2002. According to the needle-tube principle of communicating vessel the inner diameter of inlet substrate pipeline should be 250-350 mm and inner diameter of outlet pipeline one size under it 200-250mm;
- Gasholder and gas pipe will use the same plastic pipeline with an inner diameter  $\geq 25$ mm depending on the length of gas pipe and how the gas is used on the farm;
- Safety valve: before connecting the inlet pipe with the main gas pipe, install an auto-release gas valve in order to avoid over pressure in the digester in case the biogas, which is not used up, will be stored in the digester for a long time.

### **5.3 Defining the levels for biogas components and reference line for construction**

On the selected site, define the location of the biogas components including mixing tank, digester, and compensation tank. Take the end point of inlet pipe as the reference point to identify the levels of other components throughout the construction site.

### **5.4 Excavation**

#### **5.4.1 *Excavation tools***

- Excavation tools include the tools to dig and transport the excavated soil, such as hoes, shovels, spades, baskets, carrying poles or carts. For sites with convenient access an excavator can be used.

#### **5.4.2 *Digging***

- The digester pit is excavated first; the hole for the digester is 1 metre bigger in each dimension than the design size of the digester to allow backfilling. The wall of the hole can be vertical or inclined depending on the soil (*see*

Table 5.3). In case of soil erosion, bamboo poles need to be inserted to soil collapse during the construction process.

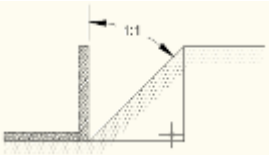
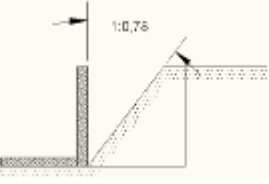
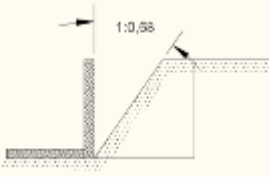
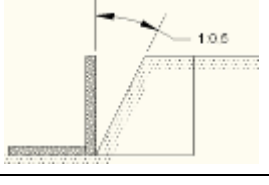
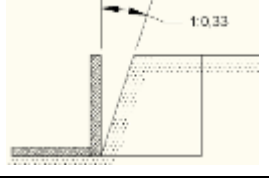
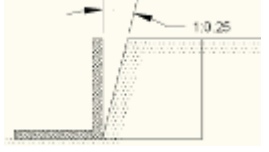
Type of soil	Slope	
Sandy soil	1 : 1	
Sandy loam	1 : 0.78	
Soil with pebbles and cobbles	1 : 0.68	
Loamy soil	1 : 0.5	
Clay	1 : 0.33	
Dry loess soil	1 : 0.25	

**Table 5.3 – Minimum allowable slope of the pit wall**

- In case there is underground water, excavate a ditch around the perimeter of the excavation so that the water can be collected and pumped out regularly during the construction. Meanwhile increase the dimensions of the excavation pit to accommodate this trench.

- Use waterproof cement for the ground to improve tightness against ground water
- Pay attention to the soil level at the construction site, if it is significantly different from the drawing it needs to be discussed with the designer to determine another suitable construction method.

## 5.5 Bottom concrete

### 5.5.1 *Foundation consolidation*

The bottom of the medium-scale plant covers a large area, thus, the foundations of the hole must endure the weight of the whole plant and meet the requirements of the plant during operation. If the biogas plant is constructed in low intensity soil, the foundation should be carefully treated as per in the Table 5.4.

Degree and group of soil	Terms of application	Methods for base consolidation	Methods for foundation consolidation
I-1-degree soil (gravel poor), I-2-degree soil (gravel mixed poor)	Soil is loosely packed and weak. Soil with little underground water. The depth of the weak soil layer is less than 0.5 meter.	Use the method of tightly ramming.	Use concrete foundation.
	Soft and wet soil, peat, silt, mud, topsoil, etc. Weak soil layer permanently submerged in water.	Driving in bamboo stakes or cajuput stakes.	
	The project area was rather large than one planned. The underground water level was not high.	Replacing the project base with a new one.	
	There was a sandy layer above or under the weak soil layer. Large project area, and there is no need to be hurry.	Use the previously load-added method.	

I-3-degree soil (gravel, mixture), II-degree (sand) soil		No need to consolidate the project base	Use the concrete foundation
III-degree soil (clay), IV-degree soil(silts)		There is no need to consolidate the project base.	There is no need to consolidate the project foundation.

***Table 5.4 – Soil type and foundation guide***

### ***5.5.2 Casting the concrete foundation***

- The dimension of the formwork and metal reinforcement rods for the concrete foundation must strictly follow the design drawing.
- Ensure concrete is well mixed before pouring and that once poured, is sufficiently agitated to remove air bubbles and good contact is made with the metal reinforcement rods.

### ***5.5.3 Concrete curing***

Hot or windy weather makes the drying out process of concrete quicker so that risk of surface crack or weaknesses because it does not develop full bond between all the ingredients.

To avoid this, concrete slab can be cured after pouring by:

- with a plastic sheet laid on top of the slab stops the evaporation process;
- keep regularly wetting during the day with water sprayed on the slab with garden sprinklers or hand held hose;
- forming a dam wall of sand around concrete slab and then flood it with water.

The duration concrete takes to cure can last up to 20 days, depending on weather. Inspection and validation by a building engineer should take place to confirm.

## 5.6 Digester wall construction

- It is important that bricks are neither too dry nor too wet. Begin with dry bricks that must be dipped quickly into water before building. Wet (i.e. saturated) bricks must not be used and should be properly dried before using.
- Bricks shall be laid in a standard brick wall pattern ensuring each horizontal layer is offset from the one before it. Perforated bricks should be laid to ensure air tightness for the digester.
- The joint mortar must form a good seal on all sides of each brick.
- It is recommended that a centre point and radius string be used to ensure the dome structure at each end of the digester is evenly shaped as in the design;

## 5.7 Formwork and casting the concrete for the covers

- Concrete covers for the compensation tank and the digester are cast in-place with reinforcing steel. The dimensions and steel grids are in line with the technical drawing.
- The formwork is made of wood or steel and should be well constructed to ensure a quality final product.
- The covers of the compensation tank can be cast in some slabs but a manhole should be provided to allow observation and maintenance.

## 5.8 Plastering work

- Inside and outside plastering of all brickwork must be done, however, the process involved for each is different.
- Plastering layer of the outer side is 1centimetre thick and must be pressed smoothly.
- The plastering work of the inner side plays an important role in ensuring the gas tightness and water tightness of the tank. So the plastering must follow the processes of multiple thin layers:
  - 1st step: paint 2 pure cement layers uniformly on the inside using ratio of water: cement of 0.4 : 1.

- 2nd step: plaster a mortar layer (ratio of cement : sand of 1 : 2.5) with 1 centimeter thickness and press carefully 2 – 3 times before the mortar becomes hard.
- 3rd step: paint the last layer using pure cement paste.
- Where the inlet pipe enters the biogas dome, the innermost layer will be painted with a special waterproof layer.
- An emulsion paint or paraffin paint can be applied to the upper third of the interior to further guarantee gas tightness on.

### 5.9 Installing the inlet and outlet pipes

- The inlet and outlet pipes are arranged on an alignment, usually centered on the lateral side digester.
- Usually the inlet pipe is going in the digester deeper (lower third of the digester height) than the overflow pipes on the opposite side (center of the digester height);
- Attention must be paid during installation that the mortar used for sealing around the point of connection must be mortar with a compression strength of 100 or 150 MPa, fully filled and carefully rubbed to prevent water and gas leakage
- A PVC pipe can be casing in the digester wall as socket so that after the drying, the proper pipe can be slip in the hole and will be fixed by adjustable ring seals screw.

### 5.10 Backfilling

- Back-filling around the wall should be done as soon as the inlet and outlet pipe connections are completed. This will prevent the tank from floating in the event of bad weather such as heavy rain or too much groundwater.
- The back-filling process is implemented as follows:
  - Use sand for base layer of about 0.5m and soil for the remainder. The back-filling must be carried out carefully and evenly around the digester.

- Back-filling should be carried out in 20 cm thick layers, each layer should be tightly compacted before back-filling the next layer.

### 5.11 Safety in construction

During construction process the masons must follow the safety measures as follows:

- Wearing work shoes and helmet is required;
- Wear gloves;
- Safety glasses must be used at all times when welding or using power tools;
- First aid medical supply bag should be present;
- Working person should be familiar on safety measures and briefing have to take place before starting work or shift change;

### 5.12 Water-tightness checking

#### 5.12.1 *By observation from the inside*

- After completion, the digester should be observed from the inside with a projector or stronger lamp to inspect for cracks on the wall.
- Tap the digester wall to find hollows and/or enclosed spaces. If a crack or a hollow is discovered, it must be repaired immediately.

#### 5.12.2 *By using water*

- After observation from the inside, the construction is checked by filling the digester with water. After filling the digester with water to “outflow level”, the constructor needs to wait until the water level is stable, it should be marked on the wall. If the water level change is less than 5 cm after 24 hours, there is no water leakage.
- If the water level does not stabilize as per above rule, the digester cannot be water tight. Typically the water level will continue to decrease until it reaches the leak level inside the digester. The digester will need to be drained, dried and the leak repaired.

- Note:



- During checking, all the covers must be opened for easy observation at different views.
- Prevent wastewater from flowing into the digester.

### 5.13 Gas-tightness checking

The gas-tightness test of the digester is conducted after the system is water tight proven if not it will be difficult to conclude which is the problem.

#### 5.13.1 *Checking the gas tightness of the digester*

- To check the gas tightness of the digester, fill the digester, inlet and outlet pipes with water to prevent gas leakage.
- Close digester and seal cover with clay (all covers must be tightly covered).
- Connect the digester with manometer and tightly close the valve to keep the gas in the digester.
- Add water to the digester to increase gas pressure and watch if pressure reaches up to 50 cm of the water column and then stop adding water.
- The digester should then be left for 24 hours. If the water column in manometer changes less than 2 – 3 cm, the digester is shown to be gastight. In case of leakage, it should be checked visually where flange and crossing point and repaired with epoxy resin. There are also on the market colored trace gas that can be spray in the digester to find the place of leakage

#### 5.13.2 *Checking the gas tightness of the gas pipe*

- This checking is applied only after ensuring the digester is gastight.
- Open the main gas valve near the digester and close the gas valve at the end of gas pipe.
- Connect the manometer with the end of the gas pipe.
- Add more water into the digester, so that the gas in the digester is pushed into the gas pipe.
- If there is a whistle with constant pressure fall down at the manometer there is a leak in the gas pipe.
- Soapy water can be applied to the gas line and to areas of suspected leaks. Bubbles will form if there is a leak and need to be fixed immediately.



## 6. OPERATION AND MAINTENANCE OF THE BIOGAS PLANT

### 6.1 Put the biogas plant into operation

#### 6.1.1 *Start-up of the biogas process*

After the plant is erected and the test successful, the biogas plant has to start with the biological aspect called “seeding” to create appropriate conditions inside the digester for growth and reproduction of biogas microbes.

Inoculum is needed for seeding the anaerobic fermentation process. Any materials rich in biogas microbes, such as manure from other digester, sewage sludge or digested sludge can be used as seeding materials.

Usually, 1/3 to 1/2 of the digester volume is feed with this material. After for 3- 5 days culturing, the amount of raw material should be increased gradually. so that the biogas microbes can grow and reproduce and gradually acclimate to the new conditions the organic loading rate should be increased gradually until the design loading rate is reached.

After reaching the maximum of the digester volume, the digester is closed again for 3-5 days so that biogas can be mixed with the rest of air upper area in the digester. After this period, the biogas production and the quality in the anaerobic digester will increase gradually.

During this phase, some important operating parameters such as amount of input the fermentation temperature or pH value in the digester should be controlled.

The time schedule for the start up for householder biogas plant until the designed performance of the biogas production is attained is assumed to be between 6 to 12 weeks to produce biogas with methane contents of 55% that can be run appliance like the CHP generator.

#### 6.1.2 *Cautions for Start-up Operation*

In case the pH value and biogas yield falls, it requires stopping feeding and taking appropriate adjustment measures, for which one of the most favourite methods is to add certain amount of cow dung until the pH value and put more water to dilute, further restart feeding and operation.

It is recommended to have a professional adviser with experience during this period.

### 6.1.3 *Preparing feedstock*

#### 6.1.3.1 *Feedstock is animal dung*

Attention: Feedstock should be in the fresh state and from strong animals with proper dilution before loaded into the digester. Dilution ratio is 2 to 3 liter of water per 1 kg of fresh dung.

For cattle manure (dung and urine) with less dry matter content, the ratio of water to material is 1 - 2 litres of water per 1kg of manure. In case of cow dung (fresh dung without urine) the ratio is 3-4 litres of water per 1kg of fresh dung, depending on the moisture content of feedstock.

#### 6.1.3.2 *Feedstock are plants*

The residues of agricultural plants or organic matters from plants can be used as feedstock. When using this feedstock, it is fed chopped and in batches or semi-batches if mixed with animal dung.

The input material equivalent to 1m<sup>3</sup> is as follows:

With water hyacinth, water weed: 400 - 500 kg.

With dry corn stalks or rice stalks: 120 - 150 kg.

This kind of materials should be pre-treated before being put into the digester. The method is as follows:

- The plant wastes (roots) are crushed.
- Chopped into small pieces about 1-3 cm long.
- At the mixing tank, a piler can be used to crush material before entering the digester.

During summer, the required retention time is 15 – 25 days, whereas in winter, it will be 35-45 days.

### 6.1.4 *Dilution and mixing feedstock*

Dilution creates suitable environment for anaerobic chemical reactions to take place

inside the digester. Too little dilution or too much dilution will reduce the efficiency of the plant. Good control of dilution rate will boost the anaerobic digestion process and increase the yield of biogas production. Ideally the feedstock entering the digester is comprised of 6 – 10% dry matter.

It is necessary to separate pigsty cleaning water if there is no dung contained. If using a bypass pipe and valve to remove water surplus from the sedimentation layer, frequently check the valve to ensure its working properly to limit excessive water running into the tank.

**Note:** Dilution water should be fresh water, neither acidic nor alkaline and contain no detergents.

#### 6.1.5 *Filling feedstock into the digester*

There are different feedstock filling methods, but here it is focused on two main methods below. They are automatic feedstock filling and forced feedstock filling.

- **Automatic feedstock filling:** The feedstock automatically loads into the digester during the process of pigsty cleaning. All materials flow from the pigsty into the mixing tank before running into the digester automatically. The downside of this approach is that it is difficult to control the dilution ratio of input material. Therefore, it is necessary to regularly check the automatic valve to separate excessive water during pigsty cleaning.
- **Forced feedstock filling:** The feedstock flows into the mixing tank where it is collected before being pumped into the digester. This method requires manual labour inputs, but usually results in greater control and dilution ratio of the feedstock.

#### 6.1.6 *Quality of new plant's biogas production*

After being charged with feedstock all the gas valves should be closed to create appropriate anaerobic environmental (no oxygen) for chemical reactions. Following the onset of gas production, the main gas valve should be opened to allow gas flow to the distribution pipe and to ensure safety of biogas plant. When the pressure in the digester is high, the automatic gas valve will work to release the

gas. Regularly check the gas pipe and gas valves to prevent problems, i.e. the valve cannot automatically release gas when it is excessive in the digester. If the valve fails, biogas will escape through the compensation or feed-in mixing tank.

Initially, the biogas will be low in methane content and high in carbon dioxide level, so will not burn. For a digester connected with toilets or charged with chicken manure, during the startup phase, the anaerobic digestion process can be unstable and biogas composition may change constantly. During this period of instability it is unsuitable to use the biogas to run an engine for electricity generation. It is better to wait until methane value are over 55% ( and the end of start-up phase) and enough gas production before using it in a generator.

The components and quality of the biogas can be initially assessed through normal observation. Biogas fire has a slight blue color which is indiscernible in bright light, therefore, should be observed in a dim or shaded environment. Moreover, because there are many impurities in the first biogas produced will be torched. Biogas quality can be checked also with a gas measure unit  $\text{CO}_2$  detector.

The period of unstable biogas production depends on the kind of feedstock and the climate. If feedstock is cow or pig waste and in a warm climate above  $25^{\circ}\text{C}$ , gas should be produced after 2-3 days. After 10 days the gas production should be stable. With other feedstock and in a cooler climate, gas production may take weeks or more.

***Note: For safety reasons and avoidance of potential explosion, there must be no gas burned or naked flames near the gas holder, non-return flap (flame arrestor) are placed before biogas appliance to prevent back burning.***

## 6.2 Daily biogas plant operation

### 6.2.1 Feedstock filling

#### 6.1.2.1 General requirements

The feedstock can be loaded 1-3 times a day depending on the stable cleaning regime. The amount of feedstock entering the digester will equal the volume of slurry exiting the compensation tank.

Attention should be paid to ensure the amount of feedstock entering the digester and the dilution ratio is within the design parameters of the digester. If there is too much or too little feedstock the biogas yield will decrease because of unstable operation of the plant. When overloaded with feedstock or water, the digester will operate unstably, producing less biogas, and it can take a number of weeks for the digester to return to normal operation

#### 6.1.2.2 *Daily filling feedstock amount*

Region	Location	Daily filling amount (kg/day/m <sup>3</sup> )
I (cold)	North mountainous areas	8
II (mixed)	The North Viet Nam	10
III (warm)	The South Viet Nam	15

**Table 6.1 - Daily feeding feedstock per 1m<sup>3</sup> of the digestion tank**

#### 6.1.2.3 *Impurities and toxic substances must be avoided*

These following items should not enter the digester:

- Soil, sand or stone: will accumulate in the bottom of digester;
- Wood, stick, etc: are difficult to digest,
- Plastic, metal and inert material;
- Chemicals: detergent, oil, dye, pesticide, insecticide, dung/urine from antibiotic injected animals, etc, can kill bacteria and stop gas production.

#### 6.2.2 *Monitoring operation of biogas plant via biogas pressure*

A biogas plant under good operation always has stable pressure. If the pressure fluctuates strongly outside the day/night shift it is usually due to the following problems:

- gas leakage in the plant, pipes, valves, or biogas applications, etc, which must be remedied immediately.

- anaerobic digestion process problems.
- blocked pipeline

### **6.3 Maintenance of biogas plants**

The maintenance of biogas plant aims at ensuring its effective, safe and sustainable use. Maintenance of biogas plant is mainly removing sediment and scum every 12 or 18 months. Removing sediment is better done at the end of winter, beginning of spring, so that the restart of the plant would be easier by increasing outside temperature.

Regularly check the feedstock loaded into the main tank (if using the pump), check water-adjusting valve and inlet pipe. The gas pipe is always straight and in good condition; not cracked or bent.

### **6.4 Safety in biogas use**

#### **6.4.1 Preventing explosion**

Biogas can explode when there is 6 to 25 percent biogas mixed with air. It is important, therefore, to pay attention to the following:

- The installation of the pipeline must avoid places with the risk of fire or explosion.
- Biogas applications such as lamps and stoves must be installed in the suitable places where there is sufficient ventilation; they will not be affected by wind and not in close proximity to flammable objects. Biogas power generators should be located in a separate and well ventilated room.
- If biogas is smelt the main valve should be closed immediately and the pipeline and all fitting checked for leaks. All fires and naked flames are totally banned. Do not light a match, smoke, use kerosene lamps etc, if there is leaking biogas.
- Biogas stove and lamp operation must comply with the regulations provided in use of biogas stove and lamp
- Install flame arrestor and water trap in biogas system.



#### 6.4.2 *Preventing asphyxiation*

Biogas is typically not toxic and inhaling small amounts will have no adverse human health effects. If inhaled in large quantities, however, it can cause asphyxiation and death. The hydrogen sulfide content of biogas means it is easily smelled and detected, however, if there is a leak whilst someone is sleeping or unconscious it can cause asphyxiation. For this reason the following should be adhered:

- The site for placing, stoves, lamps and generators must be well ventilated.
- Gas lines and appliances should not be installed in closed rooms where people sleep.
- All biogas appliances must be operated and used as in the instructions for each device.
- If a leak is detected in a closed space all doors and windows should be opened to vent the room immediately and the leak identified and repaired.
- By asphyxiation suspicion, open room, door and windows or carry out the person apply mouth to mouth respiration, apply oxygen mask and call the emergency service

#### 6.4.3 *Safety issues associated with repair and maintenance*

When any worker needs to enter the digester for repairing or maintenance, the following procedures should be followed:

- No smoking or naked flames while there is a potentially explosive gas environment in the digester;
- The cover of the digester is opened and all bioslurry is pumped out;
- Wait some days until all biogas in the digester escapes or mechanically blow air through the digester to ventilate;
- -check the biogas content with a CO<sub>2</sub> alarm gauge;
- Used oxygen bottle if require;.
- Use a safety wire; be with another person outside to monitor and help.

## 6.5 Common troubles and remedies

Troubles	Causes	Remedies
1. No gas or little gas but the plant is still in stable operation	Poisoning of bacteria in digestive slurry	Re-check quality of feedstock and replace with another feedstock
	Bad quality water source	Re-check the quality of water as pH, water source
	Lack of methane producing bacteria	Add more bacterium by using slurry of a biogas plant under stable operation
	Lack of bacteria	Add bioslurry from stable digesters
	Too cold weather	Warm the digester or wait for warmer weather
	Gas leakage	Check the gas pipe, gas valves and gas appliances
	Thick scum or sediment in digester	<ul style="list-style-type: none"> <li>- Clean the digester regularly</li> <li>- closed shortly all opening to increase the pressure</li> <li>- Ensuring appropriate dilution ratio of</li> </ul>
2. Not enough gas for consumption	Too little gas	See the first item above
	Gas consumption rate is higher than gas generating capacity	<ul style="list-style-type: none"> <li>- Calculate the capacity of equipment used accordance with expected biogas production</li> <li>- Reduce the consumption</li> </ul>
3. Too much gas production	Too much input feedstock	<ul style="list-style-type: none"> <li>- Separate water before feedstock flows into input tank.</li> <li>- Find alternatives for increasing gas usage – e.g. water heating</li> <li>- Install an excess gas burner</li> </ul>
4. Materials are not automatically fed into the digester	Too solid feedstock	Add more water for proper dilution
	Inlet pipe blocked	Un-choke inlet pipe
	Inlet blocked due to thick solid in the digester	Removing solid sediment in the digester
5. Gas smells bad.	Too much H <sub>2</sub> S in the biogas	<ul style="list-style-type: none"> <li>- Install a new filter of H<sub>2</sub>S</li> <li>- add FeCl in the substrate a new filter of H<sub>2</sub>S</li> </ul>



6. Black rust metal parts	Too much H <sub>2</sub> S in the biogas	As item 5
7. Gas production is high but methane content is low	Ratio C:N Value not good	- Adjust co-fermentation input - Add some cow dung Control C:N value
8. Biogas flame jumps strongly.	Methane value not constant	Control the pressure in the biogas Check the biogas consistence
And some other problems.		

**Table 6.2 – Common troubles and remedies**

## 7. BIOGAS APPLIANCES

The effective use of biogas will increase the value of the biogas system. This is a renewable energy source of high value used for heat or electricity generation and can be used domestically or for farming purposes like CHP generator, water boiler, chicken egg incubator, tea drying unit.

### 7.1 Cleaning biogas

In biogas, there are gas impurities that are not conducive to combustion, so they have to be removed in order to increase the efficiency of the biogas and ensure the sustainable use of biogas appliances.

- CO<sub>2</sub> does not burn so it obstructs combustion of biogas and absorbs the heat.
- When H<sub>2</sub>S burns, it releases SO<sub>2</sub> which generates toxic to humans and if the water is put into H<sub>2</sub>S, it will create acid causing corrosion of metals.

There are many methods of filtration biogas including chemical and biological methods. In chemical method, there are two common methods, which are wet filtration and dry filtration (absorption method). But to save money, the air input at 1-3% of the digester volume is applying for some middle size biogas plant.

### 7.2 Biogas filtration methods

#### 7.2.1 *Biological method*

Biological filtration is the method of using aerobic bacteria to clean biogas. Biogas is passed through a filter media containing aerobic bacteria, which can deliver up to 95% of clean biogas.

#### **Result:**

- Filtering output: 25 Nm<sup>3</sup>/h - 3,000 Nm<sup>3</sup>/h
- H<sub>2</sub>S content decreased from 8,000 ppm down to < 250 ppm
- Increase the lifespan of the generator: from 5,000 hours to 30,000 hours

#### 7.2.2 *Chemical methods*

Chemical method includes the following:

- Wet method (see figure 7.1): Using an alkaline substances such as NaOH,  $\text{Ca}(\text{OH})_2$ ,  $\text{Pb}(\text{CH}_3\text{COO})_2$ ,  $\text{FeCl}_3$ ,  $\text{BaCl}_2$ . These substances dissolve in water to form solutions. Pass biogas through these solutions or create a water screen to clean the biogas.

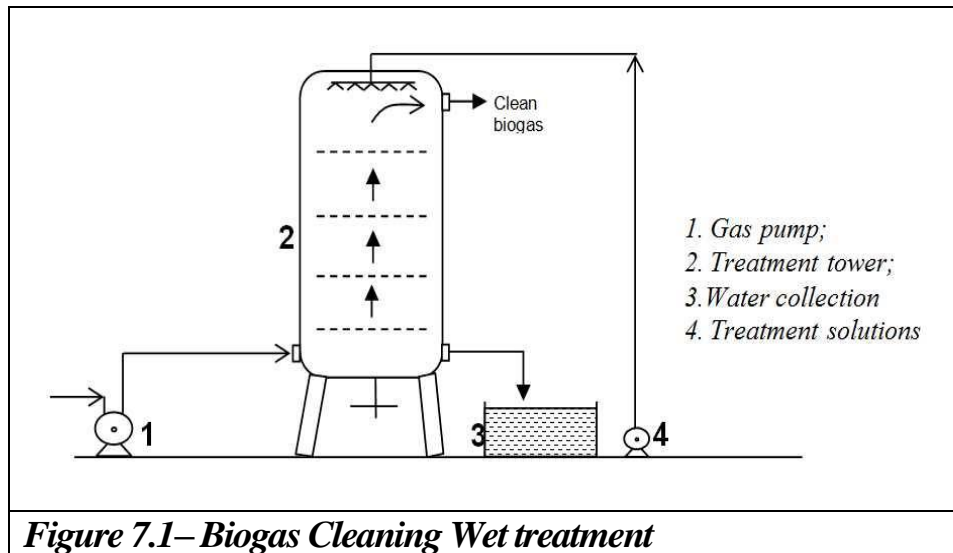

**Figure 7.1– Biogas Cleaning Wet treatment**

- Dry Method (see figure 7.2) – absorbed by solid substances: Activated carbon impregnated with the alkali or precipitated substances, reagents:  $\text{FeCO}_3$ , soda lime.

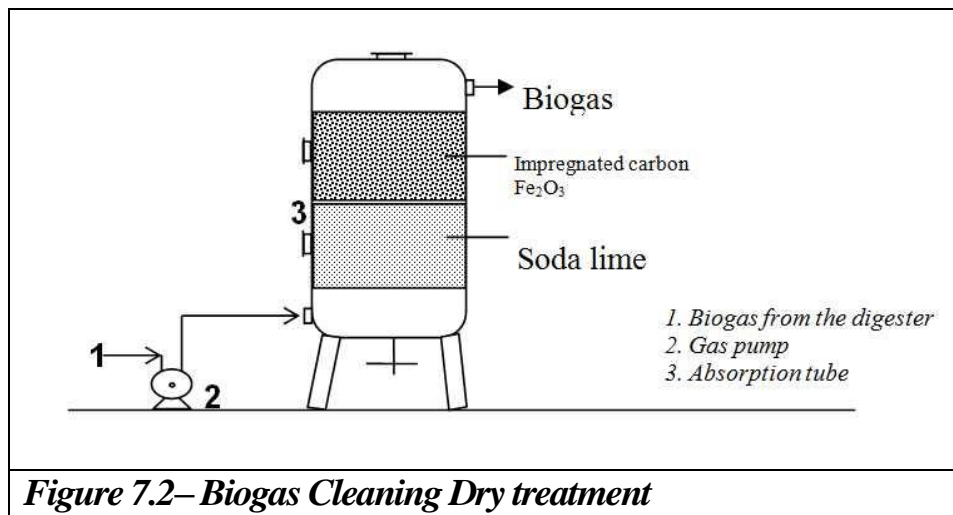

**Figure 7.2– Biogas Cleaning Dry treatment**

### 7.3 Generators fueled by biogas

Biogas can be used as a fuel replacement in internal combustion engines. The most cost effective approach is to make modifications to a standard petrol or diesel engine so it can be fuelled with biogas.

In general, biogas engines are suitable for pumps, tractors, generators and light trucks. Types of engines which are suitable for modification include four-stroke petrol engines and four-stroke diesel engines. Two-stroke petrol engines are not suitable for modification because it uses the mixture of petrol and oil for lubricating the engines.

The consumption of biogas is as follows:

0.45 to 0.54 m<sup>3</sup>/h for 1 horsepower;

0.62 to 0.70 m<sup>3</sup>/h for 1kW

#### 7.2.3 Modification of petrol engines

The modification of four-stroke petrol engine to use biogas is the simplest method. To modify the engine, a biogas-air mixer must be added to the carburetor to supply the engine with biogas. Owing to the spark plug, the mixture of biogas and air can burn easily. After modification, the engine is wholly fueled by biogas. It is typically best to install a fuel switch-over valve so that the engine can be operated petrol when there is a shortage of biogas. The switch-over valve also allows the engine to be started on petrol which makes for easier starting.

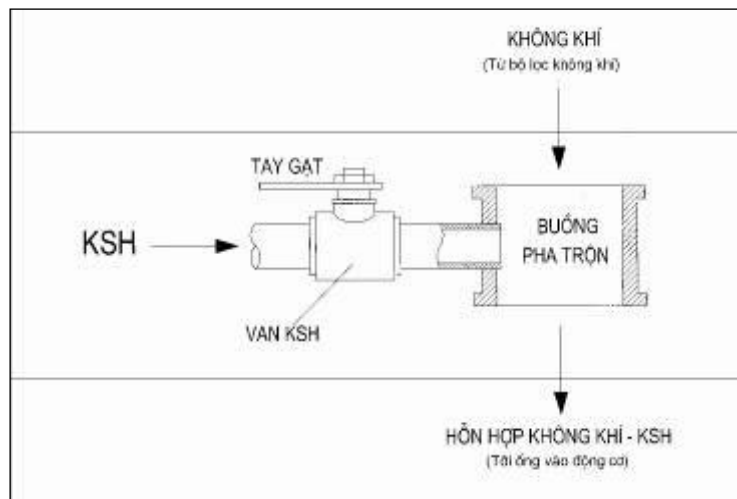

Figure 7.3– Biogas air mixer

#### 7.2.4 *Modification of diesel engines*

For typical diesel engines, the temperatures attained in the cylinder chamber during the compression stroke rarely exceed 700°C. At this temperature, the biogas-air mixture will not ignite. The auto-ignition temperature of a biogas-diesel mixture is greater than 800°C, hence the compression ratio in a standard diesel engine is not sufficient alone to ignite biogas. Although modification to the compression ratio is possible, this is a complicated and costly procedure. It is also possible to retrofit a diesel engine with a spark plug to initiate combustion, however, this is also deemed an overly costly and technical solution.

A significantly easier and more appropriate approach to modifying a diesel engine to operate on biogas is to retrofit a biogas-air-mixer to the air intake side of the diesel engine. The biogas-air mixture is drawn into and compressed in the cylinder chamber and ignited upon the injection of diesel into the now hot gaseous mixture. The governing system on the diesel engine will automatically control the volume of diesel injected to compensate and typically results in a diesel fuel reduction of 15 to 25 percent.

The advantage of this approach is that it is a relatively simple modification to the engine and that then engine can return to running on diesel if there is no biogas.

#### 7.2.5 *Installation and operation of biogas generators*

Generator position requirement:

1. Outside the house under rain protection or special room with exhaust gas pipe free;
2. Dry and protected location;
3. Does not require long wiring to end-user point;
4. Located at least 3m away from flammable objects.

Electricity connection from generator to electric system of the farm is as in the figure below.

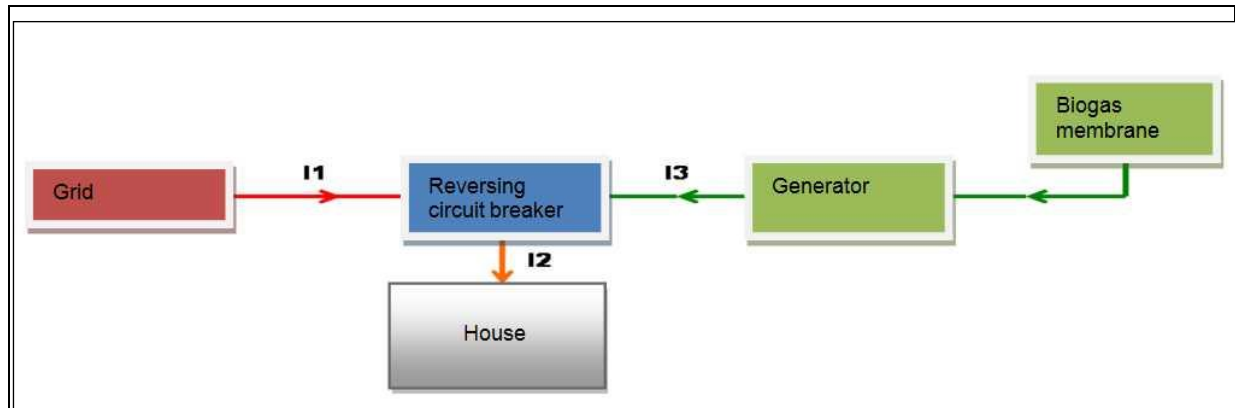

**Figure 7.4– Electricity connection between CHP a. Farm**

The power derived from biogas generators can be directly connected to the electric system of the farm through reverse circuit breaker. Moreover, the power supply from biogas generator is AC power, so it is easily integrated into the current power distribution system on the farm. In this case, the biogas power supply is connected to the on-farm grid through a reverse circuit breaker. The users open and close the circuit breaker when using power from the desired power supply. Automatic circuit breakers can also be installed which will automatically disconnect grid connection once a biogas generator is started.

In case the power supply ( $I_3$ ) has lower capacity than the farm load ( $I_2$ ), it is possible to use load-sharing power equipment to use a parallel power system from biogas generator and power grid. However, if the power supply is greater than the load capacity, it is very wasteful and affects the quality of the generator as well as the quality of the electric appliances. Thus, it is better to size the biogas generator appropriately for the power demand and use load management practices on the farm to avoid power demand spikes.

### 7.2.6 Operation of biogas generators

Before operation of biogas generator perform the following inspections:

1. Check there is sufficient biogas in the digester or air bag.
2. Check oil level in the generator, ensuring all valves are closed.

Components of a biogas generator as in the pictures below.



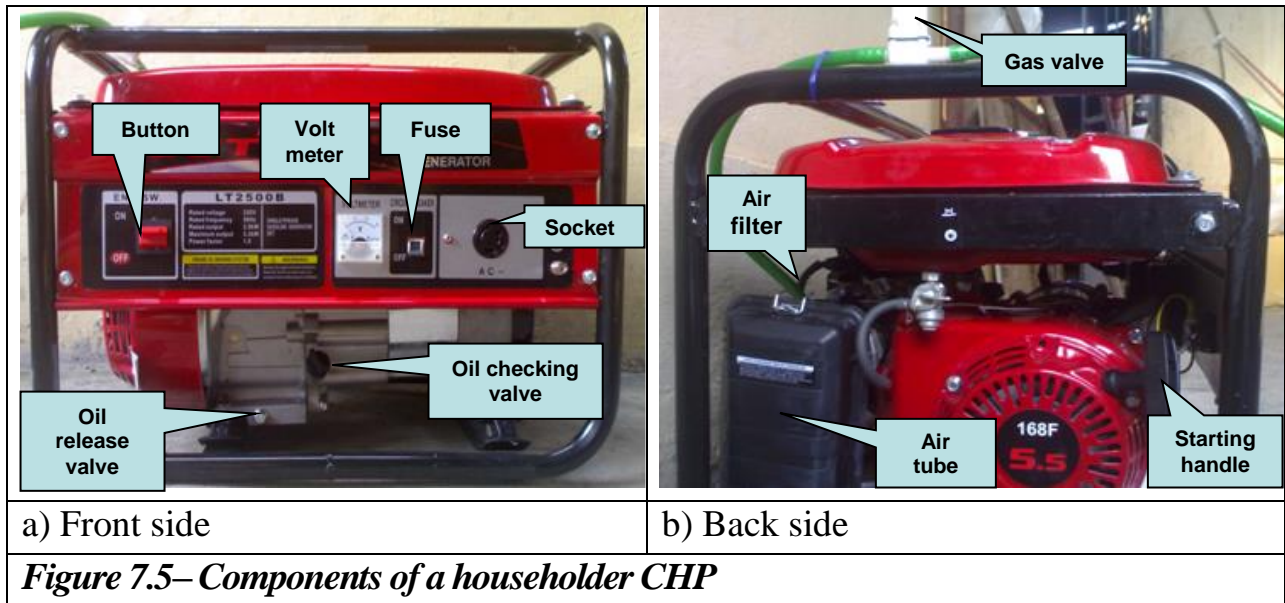

Procedure for starting biogas generator following inspection checks:

- Close circuit breaker on the panel ;
- Close air filter;
- Open the gasoline valve;
- Switch the engine to on position;
- Pull starting handle (for engines without the automatic start-up system);
- Once the engine is running smoothly, open the wind filter .

When the engine runs smoothly and the voltage at voltmeter indicates 220V-240V, open the circuit breaker for the electricity to run into the electricity distribution system. When the generator is not used, the shutdown actions will be in reversal order: i) close the circuit breaker; ii) close gas valve; iii) close the wind filter and engine.

The requirements for generator operation:

- To understand the principles of internal combustion engines and generators in general;
- To properly and safely use and maintain the generator;
- Do not smoke when connecting or removing the biogas pipe to the generator;
- Do not smoke and use lighters when starting the generator.



### 7.2.7 *Maintenance of generators*

Generator has to be maintained frequently to ensure efficiency and safety in operation and increase the lifetime of the machine. Follow the maintenance schedule outlined in the operating manual, which should include the following important maintenance measures:

- Check the oil level frequently and change oil as per service schedule;
- Check, clean or change the air filter as necessary;
- Check and clean spark plugs regularly;
- Clean and oil the valves for easy controlling;
- Check exhaust manifold for carbon deposits and clean as necessary.

### 7.2.8 *Trouble shooting and remedies*

Problems	Reasons	Solutions
Difficulty in starting	Overload	Start in no-load mode
	With dual fuel biogas engine, injector nozzle blocked or burnt out	Clean or replace
	With one fuel biogas engine, component of biogas of mixed gas is too high or low	Adjust boot valve, increase pressure of biogas
	Spark plug voltage is low	Check battery's voltage; ensure the connection of circuit
Output capacity is not enough /Low output capacity	Component of biogas is low	Increase amount of biogas in mixed gas
	Compression loss	Check the input/output valves, cylinder cover gasket, piston rings
Engine slows and/or stops after manually opening air supply valve (dual fuel biogas engine)	Biogas-air mixture is too rich	Open the input valve slower
Lubricating oil is being degraded	Hydrogen sulfide component of biogas is high	Filter hydrogen sulfide, replace oil frequently

**Table 7.1 - Trouble shooting and remedies by an householder CHP**

## 7.4 Biogas water boilers

### 7.4.1 Classification of biogas water boilers

Biogas water boilers follow the same principle of other fuel-based water boilers such as natural-gas and LPG water boiler.

There are two kinds of water boilers available:

\* *Water boiler without storage tank have the following characteristics:*

- Immediate water heating to meet demand.
- Convenient if there is limitation of space.
- Unable to provide sufficient hot water if there is high demand.
- 



a) Picture

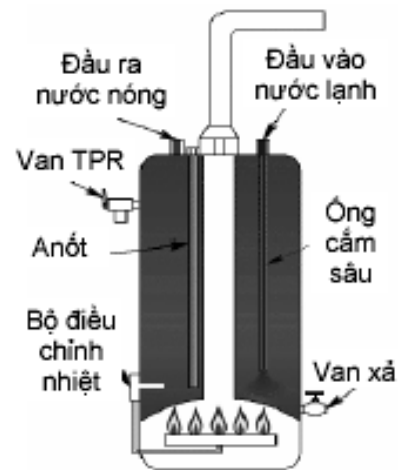

b) Scheme

**Figure 7.6– Components of a water boiler with storage**

- *Water boiler with storage tank has the following characteristics:*
  - Lower cost in comparison with the former.
  - Bigger and more cumbersome than the former.
  - Not convenient if installation space is limited.
  - Suitable if there is high demand for hot water.

#### **7.4.2 Structure and operation**

The water boiler consists of an gas nozzle, an injector and a water tank. For device with storage tank, water is stored in the tank and the injector will provide heat for boiling water. For device without storage tank, cold water goes through a heat exchanger that laid in the combustion chamber. The injector supplies the burning chamber biogas for heating.

The device is usually equipped with automatic controlling units including an ignite on/off gas valves and a thermostat.

### **7.5 Biogas heated chick incubator**

Utilising biogas to heat hatching incubators for chicks is relatively mature and widely applied technology in China. During the past 10 years Institute of Energy in Viet Nam has studied many types of chick incubators fueled by biogas at household scale - i.e. an incubator with capacity of 500 to 3,800 eggs/ batch, high thermal energy use, and biogas consumption of 0.06m<sup>3</sup>/hour in winter and 0.018m<sup>3</sup>/hour in summer. The biogas chick incubator provides stable temperature and humidity conditions and evenly distributes heat with less than 0.2-0.95°C difference in temperature. This is appropriate equipment for rural application because it has a suitable structure, reasonable price and is easy to operate.

#### **7.5.1 Components of the incubator**

The incubator consists of two main chambers: incubation chamber and hatching chamber, egg trays, egg-turning mechanism, biogas heating element, heat controlling and vent valve..

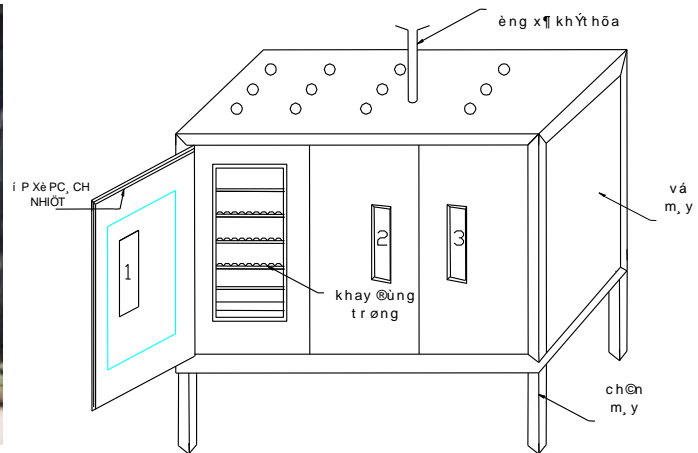

**Figure 7.7 – Components of a biogas chick incubator**

### 7.5.2 Heating element

The heating element of an incubator consists of a biogas burner, a water tank, a heat exchanger and a ventilator (see Figure 7-7).

### 7.5.3 Temperature regulator

It is the horizontal part of water supply system fitted with four sets of vertical doors to create 4 evaporation bowls. The size of the evaporation bowls is proportional to the capacity of the incubator.. During incubation period, the area of the evaporation bowl can be adjusted according to different requirements on moisture.

### 7.5.4 Air exchange system

Air exchange system includes 8 air intake pipes installed at the bottom of the incubator and 20 exhaust lines installed in two doors of the device. Wind doors are opened at two sides of the incubator. The doors are located symmetrically and covered with a slipping glass that can be used as a hole for checking and adjusting the wind doors.

## 7.6 Tea drying by biogas

Biogas can be used for provision of thermal energy in green tea production with manual or semi-manual processing methods. This processing system has been popularly applied in China and only under demonstration phase in Viet Nam. The research results of the Institute of Energy show that application of biogas in tea drying has the following characteristics:

- Flexibly applied in the manual drying ovens or semi-manual drying ovens
- Energy saving: lower fuel consumption
- Keep the flavor and color of tea compared to the traditional technology



a) Manual drying oven



b) Semi-manual drying oven

**Figure 7.8 – Green tee drying processing**

## 8. BIOSLURRY UTILIZATION

Bioslurry, or effluent, is a by-product of the anaerobic digestion process and its exploitation and use can bring added economic benefit to the use of a biogas digester. The most common economic benefits attained from bioslurry utilization result from using it as an organic fertilizer and an additive to fish ponds to enhance fish growth.

### 8.1 Characteristics of bioslurry

Fully digested bioslurry is odourless, does not attract flies or insects and consists on average of 93% water and 7% dry matter of which 4.5% is organic and 2.5% is inorganic matter.

In the process of anaerobic decomposition of organic matter the nutrients are preserved in the bioslurry while most of the organic component is converted into biogas. Soluble nutrients remain in both the liquid fraction and are also absorbed into the solid residue (see *Table 8.1*).

	N (g/l)	P <sub>2</sub> O <sub>5</sub> (g/l)	K <sub>2</sub> O (g/l)
<b>Biogas digested effluent</b>	0.37 – 0.80	0.099 – 0.31	0.32 – 0.56
<b>Solid residue (approx)</b>	0.562	0.376	0.96

***Table 8.1 - Nutrient elements of bioslurry***

It is an excellent soil conditioner as it adds humus and supports the micro-biological activity in the soil increasing the soil porosity and water holding capacity. It has greater fertilizer value for crops and feed material for earthworms, livestock and fishponds.

The nutrient load in bioslurry is typically greater than that preserved in aerobically composted animal manures or uncomposted manure (farm-yard manure) as highlighted in Table 8.2. This is because there is nitrogen loss in aerobic composting whereas there are negligible losses in anaerobic digestion. Additionally, digested manure has a greater fertilising value compared to farm-yard manure because the nitrogen is available in a form that can be more readily absorbed by plants.



Nutrients	Compost Manure		Farm-yard Manure		Digested Bioslurry	
	Range %	Average %	Range %	Average %	Range %	Average %
<b>Nitrogen</b>	0.5-1.5	1.0	0.5-1.0	0.8	1.4-1.8	1.6
<b>Phosphorus</b>	0.4-0.8	0.6	0.5-0.8	0.7	1.1-2.0	1.6
<b>Potassium</b>	0.5-1.9	1.2	0.5-0.8	0.7	0.8-1.2	1.0

**Table 8.2: Nutrient values in different types of organic fertiliser (Gupta 1991)**

In addition to the nutrient elements such as nitrogen (N), phosphorus (P) and potassium (K), bioslurry also contains organic matter and other materials beneficial for crops. Bioslurry is rich in humic acids, cellulose, hemicellulose and lignin compared to compost, making it a better soil conditioner than compost. Research and experience have additionally proven that bioslurry application can limit pests and weeds. Bioslurry can inhibit some pathogenic bacteria such as brown spot disease in wheat and rot in sweet potatoes.

When organic matter undergoes anaerobic decomposition, part of the nutrients is absorbed by the bacteria to grow and form new biomass and a part is turned into amino acids. One study on cow manure saw the total amount of amino acids increase by 230% following digestion. In addition, a significant amount of vitamin B<sub>12</sub> is synthesized during the decomposition process.

Due to these characteristics, bioslurry has been widely applied in agricultural farming as fertilizer for crops and animal feeds which brings high efficiency.

## 8.2 Using bioslurry as fertilizer

Bioslurry is an excellent fertilizer and soil conditioner. It is environmentally friendly, has no toxic or harmful effects and can greatly reduce the use of chemical fertilizers. It provides nutrients and humus to the soil that encourages micro-biological activity in the soil. This in turn increases the soils porosity and water holding capacity, helping restore the symbiotic relationship between nutrient content, organic content, soil structure and biological activity.



In addition to the major plant nutrients, it also provides micro-nutrients such as zinc, iron, manganese and copper that are also essential for plants, but required in trace amounts.

Bioslurry comes in two forms: digested effluent (i.e. liquid fraction) and solid residues. As shown previously in Table 8.1, both the liquid and solid fraction has beneficial nutrient value. Therefore, to achieve maximum benefit from the bioslurry, both liquid and solid fractions should be utilized.

Solid residues, which are rich in organic substances and humic acid contents, exhibit both slow and fast nutrient release effects making them suitable for basal fertilization. When using this fertilizer for dry fields, it should be covered by a thick soil layer of 10-12 cm. When applying this fertilizer for wet fields, the fertilizer should be evenly distributed across the plowed field after the first plowing. Subsequently, the field should be carefully harrowed to mix the soil with fertilizer.

If the feedstock is mainly pig manure, it is necessary to add water to the digested effluent before using. Furthermore, the digested effluent will continue to be digested once it has left the digester and this can damage the shooting process and root development of plants. To increase efficiency, this bioslurry should be kept several days in a holding tank and the sedimentation should be anaerobically digested for another 15 days more.

### **8.3 Using bioslurry for fish production**

#### ***8.3.1 Raising fish in ponds***

Raw bioslurry can be used as fish feed in ponds or lakes and also be used to fertilize aquatic plants, which are ultimately eaten by the fish. As a fish food, it can account for up to 70% or 20-30% depending on the fish type – either omnivorous or non-omnivorous. If mixing bioslurry with other feeds, the fish stocked in a pond can be carp, bream or other types of fish.

When using bioslurry it is important to ensure oxygen levels in the pond are sufficient. If too much bioslurry is applied to the pond, nutrient levels will increase thereby allowing the population of micro-organisms to rise, which in turn depletes

oxygen levels. If fish are regularly dying the rate of bioslurry application should be reduced or the water should be mechanically oxygenated.

### ***8.3.2 Raising fish in rice fields***

Bioslurry is also used for fish farming in rice fields. Before transplanting rice seedlings, channels 0.3 metres deep and 0.3 metres wide must be dug into the field forming a grid pattern. Additionally, larger channels need to be dug around the perimeter of the field in which the fish will inhabit majority of the time. These channels should be 0.6 metres wide and 0.5 metres deep.

Stocking the rice field with fish should proceed 5-7 days after rice transplantation, when the water level in the field is about 6-9cm. Bioslurry fertilization of the field can begin immediately and should be applied once every eight days at the edge of rice fields, but not where the fish are living. When spraying pesticides, ensure they do not contaminate water by spraying on the rice leaves only.

## **8.4 Production of compost and biofertilizer from agricultural waste and bioslurry**

### ***8.4.1 Production of compost***

It is possible to use some agricultural residues mixed with bioslurry to produce a high-quality compost and as indicated in the method below:

- Collect and store rice straw, water hyacinth or grass until they become dry and withered;
- Apply bioslurry onto organic material and mix well. The amount of bioslurry should be approximately 3 times more than the volume of organic material;
- Attention must be paid on the keeping the compost heap moist by regularly applying additional bioslurry;
- When the temperature of the heap reaches 40-50°C, compress well to avoid nutrient loss;
- After 2 to 3 weeks, mix the heap and add superphosphate of 2 - 5% by volume, then compress it well as before;
- Following another 1.5 to 2 months, a high quality compost fertilizer with characteristics similar to manure is ready for use.

#### 8.4.2 *Production of micro-organic fertilizer*

Micro-organic fertilizers are slow release and should primarily be used as basing fertilizer. Depending on fertilization and farming practices, NPK fertilizer can be reduced by 40-45% in the third crop cycle when using micro-organic fertilizer. From the fourth crop cycle onwards, continue the 40-50% reduction of NPK fertilizer compared normal usage. For plant protection chemicals, farmers can typically reduce by 20-35% compared to normal usage from the second crop cycle. Micro-organic fertilizer can be produced from bioslurry using the following methodology. The volumes indicated below will produce a tonne of fertilizer.

<b>Ingredient</b>	<b>Volume</b>
Agricultural residues: e.g. rice husk, straw, stems, beans, water hyacinth, sweet potato sprigs, living waste	2.5-3 m <sup>3</sup>
Peat coal (if any) or dry sludge	200 kg
Digested effluent	200-500 L
BioVAC	0.5 kg
BICAT catalyst	0.5 L

**Table 8.2 - micro-organic fertilizer**

#### 8.4.3 *Methodology*

- Shred dry ingredients into lengths of 10-15 cm and mix well.
- Mix 0.5 kg of BioVAC and 0.5 liters of BICAT catalyst with about 50-100 liters of liquid bioslurry. Add to agricultural residues and mix well.
- Compress mixture into a pile and cover with mud or straws.
- Mix the pile every 20 days and re-cover. Following 45-50 days of anaerobic digestion the micro-organic fertilizer is ready for use.

### 8.5 **Use of compost and micro-organic fertilizer**

Some methods using bioslurry compost and micro-organic fertilizer for rice and other crops as follows:

Crop	Region	Harvest	Amount of fertilizer per ha	
			Basing fertilizer	Additional fertilizer
Paddy rice	Red river delta	Spring harvest	8 - 10 tonnes of compost 30 - 32 kg N 80 - 90 kg P <sub>2</sub> O <sub>5</sub>	<i>Hasten branch:</i> 20 kg N; 2.5 - 5 tonnes of digested effluent <i>Hasten rice in ear:</i> 30 - 32 kg N; 15 - 30 kg K <sub>2</sub> O; 3.7 – 7.5 tonnes of digested effluent <i>5 days after blossom:</i> 2 - 3 tonnes of digested effluent
		Main harvest	6 - 8 tonnes of compost 20 - 25 kg N 50 - 60 kg P <sub>2</sub> O <sub>5</sub>	<i>Hasten branch:</i> 15 - 17kg N; 2 - 4 tonnes of digested effluent <i>Hasten rice in ear:</i> 20 - 25 kg N; 3 - 6 tonnes of digested effluent <i>5 days after blossom:</i> 1.5 - 2 tonnes of digested effluent
	Cuu long river delta	Winter-spring harvest	25 - 30 kg N 20 - 30 kg P <sub>2</sub> O <sub>5</sub> (before harrowing)	<i>Hasten branch:</i> 17 - 20 kg N; 3 - 5 tonnes of digested effluent <i>Hasten rice in ear:</i> 25 - 30 kg N; 25 kg K <sub>2</sub> O; 4.5 – 7.5 tonnes of digested effluent <i>5 days after earing:</i> 3 - 5 tonnes of digested effluent
		Summer-autumn harvest	22 - 30 kg N 30 - 40 kg P <sub>2</sub> O <sub>5</sub> (before harrowing)	<i>Hasten branch:</i> 15 - 20 kg N; 3 - 5 tonnes of digested effluent <i>Hasten rice in ear:</i> 22 - 30 kg N; 4 - 6 tonnes of digested effluent
Peanut	Infertile soil	Spring harvest	9 tonnes of compost 10 - 15kg N 40 - 80kg P <sub>2</sub> O <sub>5</sub> 15 - 30kg K <sub>2</sub> O	<i>2 - 3 compound leaves:</i> 2 - 3 tonnes of digested effluent <i>Nearly flowering:</i> 2 - 3 tonnes of digested effluent
Maize	8 - 10 tonnes of compost; 15 - 30 kg N; 60 - 80 P <sub>2</sub> O <sub>5</sub> ; 80 kg K <sub>2</sub> O			<i>Tree has height of 10 - 15cm:</i> 15 - 30kg N; 25 kg K <sub>2</sub> O; 2 - 4 tonnes of digested effluent <i>Tree has height of 60 - 70cm:</i> 10 - 15kg N; 1 - 2 tonnes of digested effluent

**Table 8.3 – Fertiliser Value for rice a. crops**

Using bioslurry for kinds of vegetables crops as follows:

<b>Crop</b>	<b>Basing fertilizer</b>	<b>Additional fertilizer</b>
Kohrabi	8 tonnes of compost 33 - 40 kg N 90 - 100 kg P <sub>2</sub> O <sub>5</sub> ; 50 - 60 kg K <sub>2</sub> O	<i>Recover green:</i> 8 - 10 kg N; 5 - 6 kg K <sub>2</sub> O; 1 - 1,2 tonnes of digested effluent <i>20 - 25 days after last harvesting:</i> 12 - 15 kg N; 10 - 12 kg K <sub>2</sub> O; 1,5 tonnes of digested effluent <i>35 - 40 days after growing:</i> 15 - 20 kg N; 10 - 12 kg K <sub>2</sub> O; 2 - 2,5 tonnes of digested effluent
Green cabbage	20 tonnes of compost; 20 kg N; 50 - 70 kg P <sub>2</sub> O <sub>5</sub> ; 17 kg K <sub>2</sub> O	<i>7 - 10 days after last harvesting:</i> 14 kg N; 10 kg K <sub>2</sub> O; 1 tonnes of digested effluent <i>15 - 20 days after growing:</i> 10 kg N; 10 kg K <sub>2</sub> O; 1 tonnes of digested effluent
Centella		<i>7 days after last harvesting:</i> 7 kg N; 0.8 tonnes of digested effluent <i>14 days after last harvesting:</i> 7 kg N; 0.8 tonnes of digested effluent <i>21 days after last harvesting:</i> 7 kg N; 0.8 tonnes of digested effluent
Potato	25 - 30 tonnes of compost 40 kg N; 150 kg P <sub>2</sub> O <sub>5</sub> ; 60 kg K <sub>2</sub> O	<i>15 - 20 days after growing:</i> 20 kg N; 30 kg K <sub>2</sub> O; 2 tonnes of digested effluent <i>15 - 20days after first application:</i> 15 kg N; 35 kg K <sub>2</sub> O; 2 - 3 tonnes of digested effluent
Tomato	10 - 15 tonnes of compost 50 - 80 kg P <sub>2</sub> O <sub>5</sub> 50 - 60 kg K <sub>2</sub> O	<i>12 - 15 days after growing:</i> 15 - 20 kg N; 25 kg K <sub>2</sub> O; 3 tonnes of digested effluent <i>After vigorous blossom:</i> 15 - 20 kg N; 25 kg K <sub>2</sub> O; 3 tonnes of digested effluent <i>After first harvesting :</i> 15 - 20 kg N; 2 tonnes of digested effluent
Cabbage	25 tonnes of compost 100 kg P <sub>2</sub> O <sub>5</sub> 30 kg N 25 kg K <sub>2</sub> O	Ratio of digested effluent and water is 1:1 <i>Recover green:</i> 20 kg N; 2 tonnes of digested effluent <i>Small leaf stretch out:</i> 30 kg N ; 25 kg K <sub>2</sub> O; 1.5 tonnes of digested effluent <i>Big leaf stretch out:</i> 30 kg N; 1.5 tonnes of digested effluent <i>Ready to roll:</i> 20 kg N; 1 tonnes of digested effluent <i>Roll:</i> 20 kg N; 10 K <sub>2</sub> O; 1 tonnes of digested effluent

**Table 8.4 – Fertilizer Value vegetables**

---

## 9. BIOGAS TECHNOLOGY AND THE CLEAN DEVELOPMENT MECHANISM (CDM)

### 9.1 Kyoto Protocol and Clean Development Mechanism

#### 9.1.1 *The United Nations Framework Convention on Climate Change (UNFCCC)*

In order to cope with the danger and the challenges to mankind related to climate change, 155 countries including Viet Nam signed UNFCCC at the Earth Summit in Rio de Janeiro Brazil in June 1992. The ultimate objective of the UNFCCC is “to achieve stabilization of atmospheric concentration of greenhouse gases at a level that would prevent dangerous anthropogenic interference with the climate system”.

#### 9.1.2 *Kyoto Protocol (KP)*

The parties to the UNFCCC realized the necessity of stronger and more detailed commitments for industrialized countries to seriously tackle GHG emissions. After active negotiations at the third conference in Kyoto, the KP was adopted in December 1997.

KP involves commitments of developed countries to cut GHG emission at average 5.2% from 1990 levels by the first commitment period, 2008-2012 with the concrete targets of 8% for EU, 7% for the United States and 6% for Japan.

KP introduces three flexible mechanisms in order to help developed countries to implement their commitments to reduce GHG emissions. They are:

- Joint Implementation (JI),
- Emission Trading (ET),
- Clean Development Mechanism (CDM).

#### 9.1.3 *Clean Development Mechanism (CDM) of KP*

CDM is a special mechanism related to developing countries.

- *Purposes of CDM*
  - Reduce climate change.



- Assist developing countries in achieving sustainable development and contributing to the ultimate objective of the UNFCCC.
- Assist developed countries in achieving compliance with GHG emission reduction targets in flexible and economic ways.

- *Content of CDM*

CDM encourages investment in projects that reduce or avoid the production of GHG emissions. The mechanism is designed to financially reward projects that avoid the production of GHG, thereby making such projects more financially viable. If a CDM project is responsible for avoiding GHG emissions it is credited with a certified emission reduction (CER). A CER represents the equivalent of 1 tonne of avoided CO<sub>2</sub> entering the atmosphere. CERs can be sold on international markets to countries that wish to reduce their overall GHG emissions. In this manner the CDM promotes environmentally responsible projects in developing countries, with financial incentives paid for by developed countries.

- *Benefits of CDM*

- *For developing countries*

- Attract foreign investment in order to attain development targets.
- Reduced costs of developing environmentally responsible projects.
- Contribute to the ultimate objectives of KP.

- *For developed countries:*

- Have opportunities to find new investment.
- Assists meeting GHGs emission reduction commitments with lower cost than that of implementation in home country.
- Provides opportunities to promote friendly bilateral relations.

## 9.2 Biogas technology and CDM

### 9.2.1 *Contribution of biogas technology in reduction of GHG emission*

Biogas technology and utilization of biogas contributes to reducing GHG emission in two ways:

- **Waste management:** When organic wastes are decomposed under normal conditions (e.g. pig manure in a waste settling pond) a portion is



anaerobically decomposed and releases methane into the atmosphere. Methane is 21 times more potent than carbon dioxide as a GHG – i.e. one tonne of methane is equivalent to 21 tonnes of carbon dioxide in terms of contribution in global warming. If, however, this organic waste is decomposed in a biogas digesters, the methane produced is collected and can be used as fuel. On being burned, methane is converted to carbon dioxide. Burning one tonne of methane produces 2.75 tonnes of carbon dioxide. Therefore, by burning methane to form carbon dioxide, the greenhouse effect is reduced by a factor of 7.6 (equal to  $21/2.75$ ).

- **Fossil fuel replacement:** When biogas is used as a fuel it usually replaces the use of fossil fuels – e.g. in cooking stove it replaces LPG and in a generator it replaces petrol or diesel. In this manner it reduces the amount of GHG that would otherwise be released into the atmosphere.
- **Replacing use of chemical fertilizers:** Bioslurry is rich in nutrients and can be used to replace synthetic fertilizers. The production of synthetic fertilizers is a very energy intensive process of which the majority is derived from burning fossil fuels. Therefore, using bioslurry reduces the amount of GHG that would have been otherwise been produced in the manufacturing of the replaced synthetic fertilizer.

### 9.2.2 CDM projects for biogas

Under the CDM mechanism there are 3 approved biogas categories:

- Recovery of methane from animal husbandry waste treatment.
- Recovery methane from landfills.
- Recovery of methane from treating organic wastes from food production industries.

---

## 10. QUALITY MANAGEMENT FOR MEDIUM-SCALE BIOGAS PLANTS

All stakeholders and participants of the medium-scale biogas project should endeavor to develop a successful industry in Viet Nam. For this purpose the below quality control guidelines should be followed.

All technical staff involved in the project, the technical supervisors at the field, the mason teams and biogas plant owners need to seriously implement and follow the quality control process below.

### 10.1 General requirements

- Ensure appropriate site for construction. the arrangement of the installed parts must be suitable and fitting with the surrounding landscape of the farm.
- Materials used must be compliant with technical requirements on quality and quantity. Project technical staff or technical supervisors may randomly inspect a number of items to ensure proper quality requirements.
- The process of checking water and gas tightness must be monitored and evaluated under the supervision of the technical staff and provincial technical supervisor .

### 10.2 Technical staff of the project

- Conduct training and provide guidance on basic theory as well as technical requirements for medium-scale biogas plants before construction.
- Perform in-field training sessions at important stages of the construction for the provincial technical staff, masons and the biogas plant owners to understand the important points of the construction.
- Monitor, check and accept each phase in the construction process such as:
  - ✓ 1) Identify the location of the biogas plant to install the main parts and take the reference points for the construction;
  - ✓ 2) Ensure depth of the pit and methods for foundation consolidation are sufficient for site conditions;

- ✓ 3) Oversee construction of the foundations and the first two rows of bricks;
  - ✓ 4) Ensure height of inlet and outlet pipes is correct and as per design;
  - ✓ 5) Identify the elevation for the base of compensation tank (code 0-0);
  - ✓ 6) Oversee the construction of the digester dome;
  - ✓ 7) Oversee building the compensation tank and identify the position of overflow level;
  - ✓ 8) Cast concrete cover for compression tank and digester;
  - ✓ 9) Build the digester collar (neck) and
  - ✓ 10) backfilling.
- For the first biogas plant construction, continuous supervision is required from the start to handover to monitor the process of identifying the positions of the important digester elements (e.g. level of overflow), concrete casting or digester bottom building until the completion of the work to assess, update and solve the arising problems.
  - Draft the procedures and instructions for operation and maintenance work once the biogas plant has been commissioned.
  - 6 monthly checks on the operational status of the biogas plant as well as the owners' compliance with the technical requirements on operation and maintenance of biogas plants.
  - Creating of standardized tools and equipment for biogas plants such as: gas pipe systems, gas valves, safety valves and equipment used to burn excessive gas (if necessary) to ensure overall quality of the plant. Establishment of a list of equipment suppliers after design completion.

### **10.3 Technical supervisor in the field**

- Support the farm owners with technical issues such as: introducing the mason teams, advising the location for construction, purchasing supplies and materials and other advice as necessary.

- Coordinate with other technical staff to monitor and implement the field work.

#### **10.4 Mason teams**

- Actively participate in the training sessions to ensure sound theoretical understanding of biogas technology, fully comprehend the techniques and complexities of constructing biogas digesters and appreciate the importance of compliance with the quality standards.
- Check and confirm the right type of materials and quality control prior to construction.
- Competent in reading and understanding the engineering design drawings.
- Fully comply with technical requirements of the approved drawings.
- Ensure correct ratio of materials are used and that all steps required in the construction process are followed.

#### **10.5 Biogas plant owner**

- Actively participate in the training sessions designed for end-users.
- Collaborate and assist construction team in the preparation of the site and site access.
- With assistance of masons/technical supervisor, ensure sufficient quality construction materials are available onsite when required.
- Monitor daily construction with the project staff and technical supervisor.
- Comply with technical requirements and biogas plant operation and maintenance instructions.
- Monitor and update the operational status of the plant and notify the project technical staff (once a month). Specific indicators should be monitored including operational status of the plant, gas output, gas pressure and the status of the biogas equipment such as stoves, lamps, generators, etc.