



Federal Ministry
for Economic Cooperation
and Development

TECHNOLOGY

vRE Discussion Series – Paper # 05

▶ TECHNOLOGY

Power System Security in Developing
and Emerging Countries

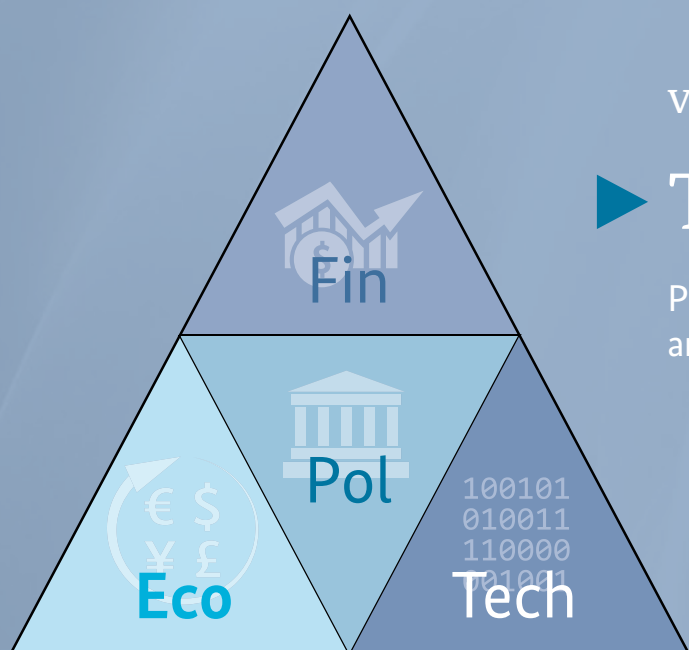

Published by

giz Deutsche Gesellschaft
für Internationale
Zusammenarbeit (GIZ) GmbH

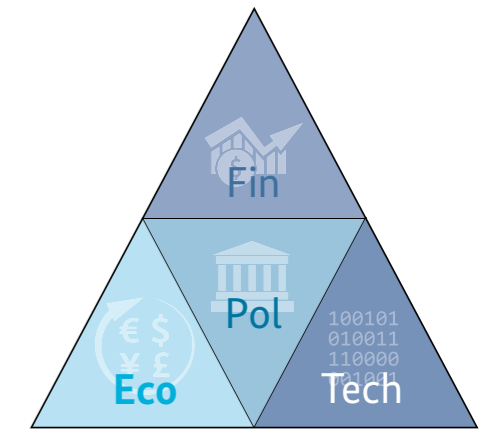

The GIZ TechCoop vRE Programme

Over the past decade, a “1st wave” of National Subsidy Programmes for variable/ fluctuating Renewable Energies (vRE) has (i) led to impressive growth in global cumulative installed capacity of wind and PV power and (ii) dramatic RE cost reductions. However, due to their typical “technology push” focus, most of these **1st wave national vRE programmes have not aimed at achieving an economically optimal pathway for national wind and PV development over time**. Naturally, this has led to suboptimal national RE deployment, resulting in (i) unnecessary losses of Government budget and credibility (subsidy schemes were too expensive or too slow, RE technologies were scaled up too early or applied at the wrong network nodes, lack of planning resulted in avoidable transmission losses or dispatch problems), and/or (ii) excessive private sector profits and/or massive insolvency waves after subsidy-driven vRE bubbles. None of this is intrinsic to vRE technologies or economics: it was simply ill-advised planning.

Increasingly, OECD and non-OECD Governments want to move beyond simple vRE technology-push policies, and shift to a new, 2nd wave of optimized national vRE pathways, by applying the same fundamental economic, financial and political goal functions that are used successfully for standard power system planning. To this end, vRE need to be analyzed as an INTEGRAL part of the national energy system and its growth in time and space, by applying methods which readily fit the toolkit already used by dispatchers, regulators and utilities.

Integrated vRE National Masterplans do not exist yet, though it is pretty clear what they would have to accomplish (IEA 2014, SMUD 2013). This has several causes, such as: (i) the inherent fluctuating character of vRE (wind and PV feed-in depends strongly on sunshine and wind availability at any given moment) poses a set of specific power planning and dispatch problems to established sector agents (dispatch, regulator, utilities) which may seem daunting initially (yet, a closer look reveals that they can be handled easily by these players with their existing processes, with a modest amount of training); (ii) existing studies have often focused on OECD countries and their results are not readily transferrable to GIZ partner countries (where grids can be weaker and demand grows faster and hydro can play a more positive role in vRE development); and (iii) few studies focus on pragmatic incremental steps based on the real-life generation mix, transmission system and fixed short-term capacity planning of specific countries (most look at long term vRE targets including smart storage >2030 instead, thus providing little guidance to pragmatic policy makers).

The GIZ vRE Discussion Series

Under the “vRE Discussion Series” we will continuously put forth emerging results and issues of special interest to GIZ partners, along the 4 main fields of our work: vRE policy, economics, finance and technology issues. As the series’ title indicates, these are often based on work in progress, and we strongly encourage suggestions and ideas by mail to the contact below.

Contact:

Klas Heising
 klas.heising@giz.de

Frank Seidel
 frank.seidel@giz.de

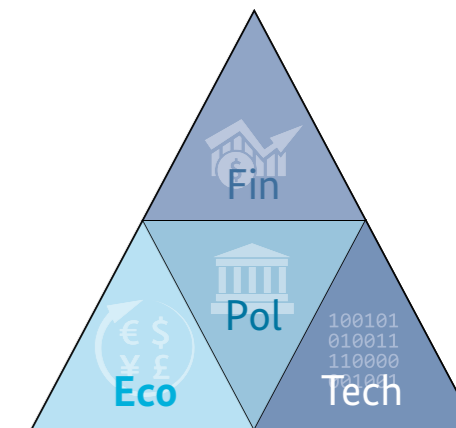

Power System Security in Developing and Emerging Countries

TECHNOLOGY

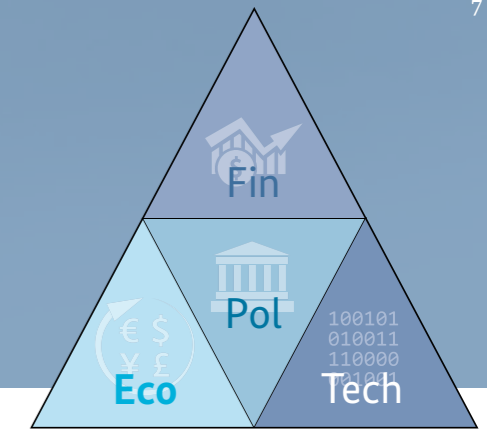
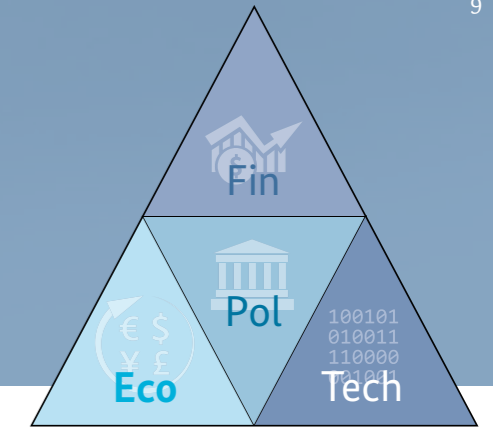

Table of Contents

1	Background	8
2	Reliability – Security – Stability: General Description	9
2.1	System Reliability	9
2.1.1	Generation Adequacy	9
2.1.2	Network Reliability	11
2.2	System Security	12
2.3	Stability	13
2.3.1	Frequency Stability	14
2.3.2	Voltage Stability	16
2.3.3	Rotor Angle Stability	18
2.3.4	Relationship between different stability phenomena	19
3	Impact of Renewable Generation on Power System Reliability and Security	20
3.1	General	20
3.2	Reliability	21
3.2.1	Generation Adequacy	21
3.3	System Security	21
3.3.1	Reserve Allocation	21
3.3.2	Grid Congestions	23
3.4	Impact on System Stability	24
3.4.1	Impact on Short-Term Frequency Stability	24
3.4.2	Impact on Voltage Stability	26
3.4.3	Impact on Transient Stability	27
4	Study Approaches	28
4.1	Generation Adequacy Studies	28
4.1.1	Objective of Studies	28
4.1.2	Methodology	28
4.1.3	Data Requirements	28
4.2	System Security Assessment	29
4.2.1	Studies relating to the Impact of Variable Generation on Operational Reserve	29
4.2.2	Steady State Security Assessment	30
4.3	Stability Studies	31
4.3.1	Short-Term Stability Studies	31
4.3.2	Long-Term Stability Studies	35
5	Summary	39
6	References	40



1 Background

Numerous developing and emerging countries have ambitious plans for the development of renewable generation. Other countries show interest in renewable generation but corresponding plans are pending due to concerns relating to the consequences of fluctuating electricity generation.

In both cases, the impact of renewable generation on system reliability and system security needs to be analysed in order to assess related risks and to propose mitigation measures for ensuring secure and reliable power system operation in the presence of large penetration of renewable generation.

The intention of this report is to provide an overview about the most relevant aspects relating to system

reliability and system security, describe the most relevant influential factors and to propose methodologies for studying the impact of renewable generation on system reliability and system security.

The structure of this report is the following

- General description of the terms Reliability, Security and Stability (section 2)
- Impact of variable renewable generation (wind and PV generation) on Reliability, Security and Stability (section 3)
- Study approaches and methodologies for executing studies relating to the impact of variable renewable generation on Reliability, Security and Stability.

2 Reliability – Security – Stability: General Description

Different definitions can be found in literature for the terms:

- Reliability
- Security
- Stability

The most relevant and nowadays most widely accepted definitions of these terms are summarized in the report of the joint CIGRÉ-IEEE task force on stability terms and definitions [1]. These definitions are repeated below:

“Reliability of a power system refers to the probability of its satisfactory operation over the long run. It denotes the ability to supply adequate electric service on a nearly continuous basis, with few interruptions over an extended time period.

Security of a power system refers to the degree of risk in its ability to survive imminent disturbances (contingencies) without interruption of customer service. It relates to robustness of the system to imminent disturbances and, hence, depends on the system operating condition as well as the contingent probability of disturbances.

Stability of a power system, as discussed in Section II (of [1]), refers to the continuance of intact operation following a disturbance. It depends on the operating condition and the nature of the physical disturbance.”

2.1 System Reliability

A satisfactory degree of Reliability represents the overall objective of the design and operation of a power

system. Reliability Indices measure the frequency and duration of supply interruptions at the customer side. A high degree of system Reliability is equivalent to a high availability of the electricity supply service. There are several factors influencing system Reliability. The most important once are:

- Generation Adequacy: The ability of the available generation capacity to supply the energy demand of the system adequately during all times.
- Network Reliability: The ability of the grid to transmit and distribute the generated energy to the end-customer.
- System Security: The ability of a system to survive imminent disturbances (contingencies) without interruption of customer service ([1]).

2.1.1 Generation Adequacy

Generation Adequacy is usually measured in terms of probabilistic reliability indices (see also [2], [3], [4]) such as:

- LOLP – Loss of Load Probability (in %)
- LOLE – Loss of Load Expectancy (in days/year or h/year)
- ENS – Energy Not Supplied (in MWh/year)
- The most widely used and at the same time the simplest generation adequacy index is LOLP. LOLP characterizes the probability that a given load level cannot be covered by the available generating capacity. Very often, LOLP is calculated for peak load levels only (assuming that lower load levels will only have minor contribution to generation inadequacy).

TECHNOLOGY

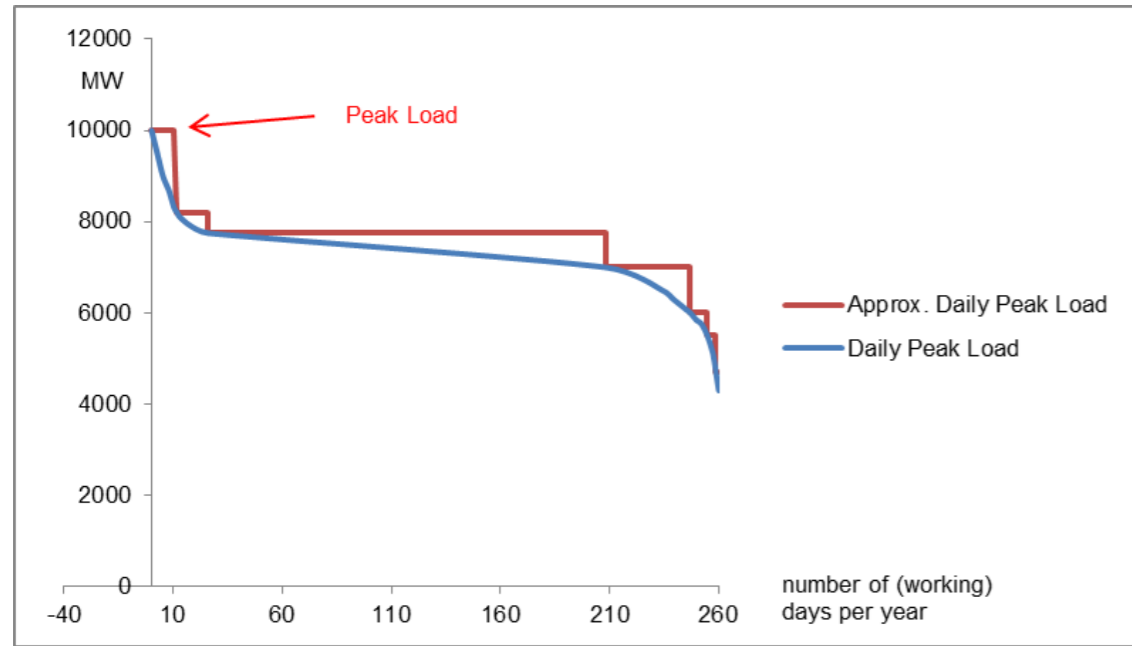

Figure 1: Daily Peak Load Duration Curve

When further estimating the number of days during which the defined peak load level is reached, the average number of days per year during which a generation deficit would occur can be estimated as follows:

$$ND = LOLP \times NP$$

with:

- ND: Expected number of days during which a generation deficit would occur (in number of days per year, see also Figure 1)
- LOLP: Loss of Load Probability at annual peak load (in %)
- NP: Average number of days per year during which peak load levels will be reached (in number of days per year)

Assuming that NP is equal to 10 and requiring that the average number of days during which a generation deficit occur would be less than one in ten years (ND<0.1), the Loss of Load Probability would be required to be less than 1% (LOLP < 1%, assuming that

the LOLP at lower load levels can be ignored). ND<0.1 represents the typical requirement for generation adequacy in developed countries (especially US and Europe).

A more sophisticated assessment of generation adequacy can be carried out when considering the actual daily peak load at either all days during the year or at all working days during the year.

Calculating all LOLPs at peak load level of all considered days, the Loss of Load Expectancy (LOLE in days/year) can be calculated. It is defined by the average value of the calculated LOLPs times the number of considered days per year.

Analogously, LOLE can be calculated at peak load levels of all hours during a year. The resulting loss of load expectancy (in h/year) is sometimes labelled LOLH. Irrespective of the calculation procedure, a generation inadequacy of less than one event in 10 years (ND<0.1) is usually considered to be the level that should be achieved for obtaining a sufficiently reliable power system.

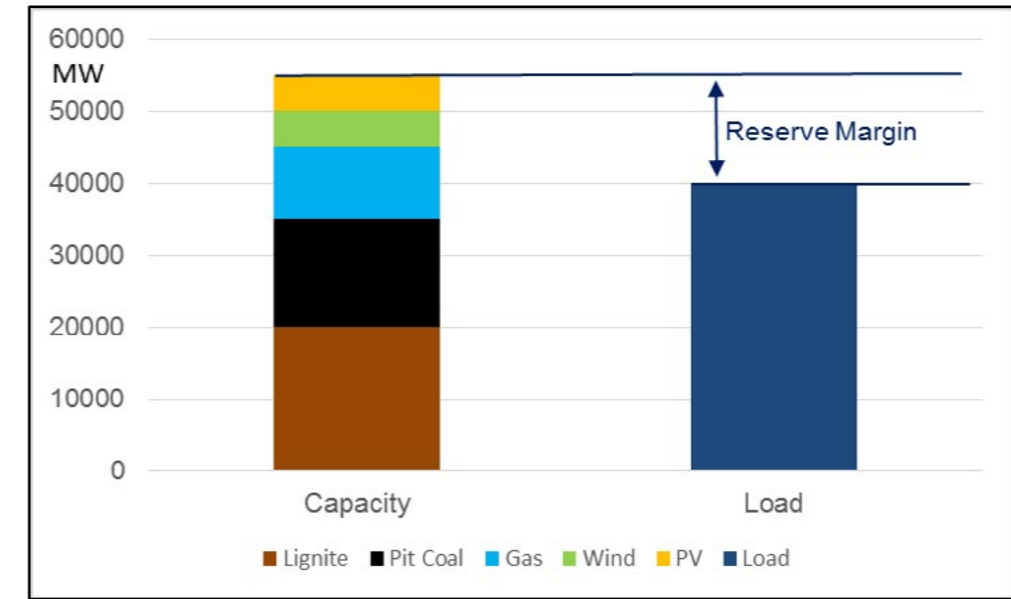
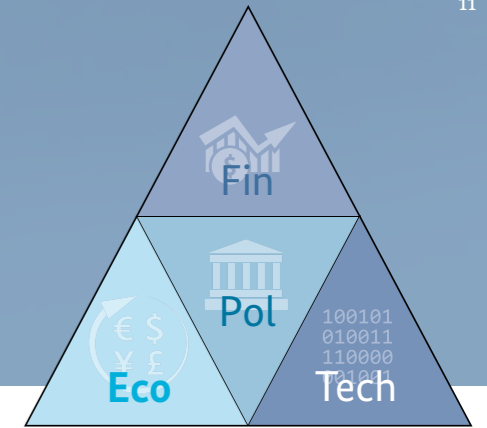

Figure 2: Definition of Reserve Margin (qualitative numbers)

A simplified approach to generation adequacy, which is usually taken for generation expansion planning purposes, is the so-called Reserve Margin. Because there are planned and unplanned outages of conventional power plants, the installed generation capacity in a power system must be higher than peak load for achieving the required generation adequacy target. The difference between installed capacity and load is defined as Reserve Margin of the system or the Planning Reserve of the system (see Figure 2).

Based on typical planned and unplanned outage rates of conventional power plants, the required reserve margin of a system can be estimated for achieving the required generation adequacy level.

In many developing and emerging countries, generation adequacy is the most relevant factor impacting reliability of supply of a power system. The load growth in these countries requires substantial investments for the installation of new generating capacity, which sometimes cannot be realized in time.

In Germany, a new discussion around generation adequacy has started some years ago, which was triggered by the governmental program of phasing out nuclear power within the next couple of years. Difficulties in replacing these nuclear power plants by new power plants within the required time scales may cause generation adequacy problems in the system of Germany in the near future.

2.1.2 Network Reliability

In developed countries, most customer interruptions are resulting from faults in distribution grids (medium voltage grids). Whereas power transmission grids are usually designed by meshed or ring structures connecting load points by more than one path to the supply points of the system, distribution networks are usually operated as radial strings, even if many distribution systems are basically designed as ring or even meshed networks. In these cases, there is always an Open Point ensuring a radial connection of each load point to only one supply point.

TECHNOLOGY

Consequently, each fault on a distribution line or cable leads to an interruption at all loads connected to the faulted feeder.

The interruption duration of a load depends on the restoration time, which again depends on:

- Time to localize a fault
- Time to isolate a fault
- Time to restore supply by carrying out appropriate switching actions (in case of ring or meshed topologies)
- Time to repair the faulted line or cable (in case of a radial topology).
- The average availability of the grid service at each supply point depends on:
 - Fault frequency
 - Fault duration

Hence the topology of distribution networks (radial or ring) and the restoration strategy have the dominating impact on the reliability of supply in developed countries, in which generation adequacy is not (yet) an issue.

Besides the above described “regular” events having limited regional impact, there are exceptional events having a much wider regional impact. Such events can be:

- Very adverse weather conditions resulting in simultaneous faults on many distribution lines (e.g. storm, ice, etc.)
- Black-outs (complete system collapse) or “brown-outs” (wide-area load disconnection) resulting from problems at transmission level.

It is very difficult to quantify the impact of these “irregular” events on system reliability because their frequency of occurrence is very low but on the other hand their consequences (or “costs”) are extremely high.

Because of the high economic impact of these “irregular” events, the probability that such an event may happen has to be as low as possible. The assessment of the probability of occurrence of events having a very wide impact is addressed by System Security.

2.2 System Security

The term System Security refers to the degree of risk in the ability of a power system to continue unrestricted operation or operation with low restrictions following a disturbance. Hence, it refers to the robustness of a power system to withstand unexpected events having severe consequences.

Customer interruption can occur because of:

- Insufficient active power reserve requiring load shedding.
- Grid congestions (overloaded lines) that require the disconnection of loads for avoiding cascading faults.
- Bus bar voltages are out of permitted ranges leading to load disconnection.
- The system runs into stability problems (frequency stability, voltage stability, transient stability, oscillatory stability or combinations of several phenomena) leading to wide area load disconnections or even a black-out.

System Security assesses “risk”, which means that both, the probability of contingencies and the consequences (or costs) of contingencies are considered.

In contrast to System Reliability, which is a long-term attribute of a power system, System Security is a time varying attribute (likewise stability) because the Security of a power system highly depends on its operational conditions. Therefore, system security assessment is not only carried out at planning time scales but also during system operation (e.g. “day ahead congestion forecast”, “contingency analysis”, etc.).

It is an important task of system operators to carry out system security assessment on a continuous basis, as part of the short-term operational planning. In the case that a threat to system security is identified (e.g. grid congestions, low active power reserve etc.) the system operator has to initiate suitable preventive mitigation measures for ensuring system security, ideally without disconnecting customers. Possible mitigation options without customer interruptions are:

- Additional reserve allocation
- Generator re-dispatch
- Re-switching of lines
- Reactive power re-dispatch (capacitor switching)

In the case that quad-boosters (phase shifting transformers) are available (e.g. in the U.K.) a system operator can also adjust the quad-booster tap settings for mitigating grid congestions.

In the case that a prospective security problem cannot be resolved, a system operator has to initiate load disconnections (planned load disconnections).

The term System Security is usually only used in the context of power transmission systems, because only severe events in the transmission system can have consequences spreading over large areas and can therefore lead to the disconnection of large amounts of customers. The consequences of faults on distribution feeders however are much less relevant to System Security because of the following reasons:

- The consequences of faults on distribution networks are much less severe than consequences of faults at transmission levels because their impact is usually limited to the disturbed feeder.
- The consequences of faults on distribution feeders are usually highly predictable because of their radial topology.

The most important exception of this is the “50,2Hz”-problem of rooftop PV-systems in Germany:

Until recently, the relevant technical standards for the interconnection of small scale embedded generators required rooftop PV systems to disconnect in the case that frequency exceeds its normal range of operation of 50,2Hz. However, in the case that this happened during daytime, almost all PV systems in the interconnected European power system would disconnect simultaneously resulting in a huge simultaneous loss of generation.

Consequently many customers would be disconnected or even a black out could occur. The reason therefore is that frequency is a global variable in a synchronized grid,

being (almost) the same in all synchronized areas and at all voltage levels (at least in the relevant time frames). In Reliability and Security Assessment, such an event is also named a “Common Model Failure” because there is a common cause for many failures.

2.3 Stability

The term Stability is a general term of systems theory. It is generally used for the ability of a system to return to a steady state following a disturbance.

The general definition also applies to power systems. However, power systems have been studied extensively and typical stability phenomena in power systems have been identified and classified.

The classification according to [1] is the most commonly referred classification of power system stability phenomena nowadays.

This classification considers the following main criteria:

- The physical nature of the resulting mode of instability as indicated by the main system variable in which instability can be observed.
- The size of the disturbance considered which influences the method of calculation and prediction of stability.
- The devices, processes, and the time span that must be taken into consideration in order to assess stability.
- Based on these considerations, the following power system stability phenomena are defined:
 - Frequency stability: Ability of a power system to balance active power (generation – load) and to maintain frequency.
 - Voltage stability: Ability of a system to maintain a steady state voltage at all bus bars following a disturbance.
 - Rotor angle stability: Ability of the synchronous machines in an interconnected power system to remain in synchronism after being subjected to a disturbance.

Besides this classification according to the main variable indicating a stability problem, stability issues in power systems can be classified in terms of:

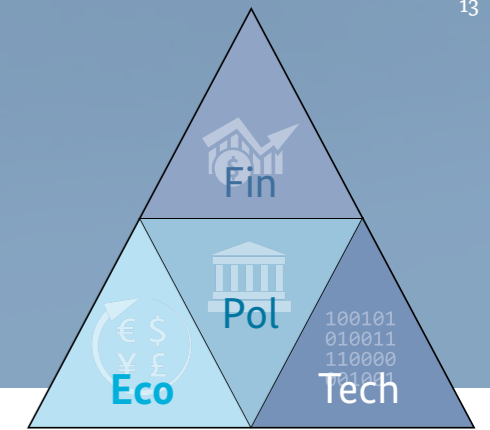

TECHNOLOGY

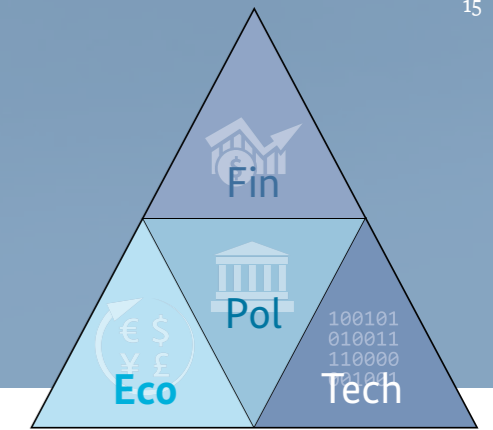

- Local stability
- Global stability

For example, a local stability issue would be the loss of synchronism of an individual generator (with subsequent trip) or the inability of an individual wind farm to remain connected in the case of a voltage dip (no Fault Ride Through/FRT capability).

A global stability problem would be the loss of synchronism of an area of an interconnected power system with all other areas or a voltage collapse that spreads over the whole grid.

Frequency stability issues (imbalance between generation and load) are always of a global nature because frequency is generally a global variable.

Rotor angle and voltage stability issues can be both, global and local.

Because the consequences of global stability problems are by far more severe than consequences of local stability issues, global stability problems are by far more relevant to System Security and will therefore be in the centre of interest of the following sections.

2.3.1 Frequency Stability

Frequency is the parameter of a power system that indicates whether there is an imbalance between active power generation and consumption. Therefore “Frequency Stability” refers to the ability of a power system to balance generation and load on a system-wide level.

Frequency instability can occur within different time frames. In the case that frequency cannot be kept within the required limits by activating the available active power reserves, a frequency stability problem can be resolved by shedding load (generation deficit, low frequency problem) or tripping (or unloading) generation (generation surplus, high-frequency problem).

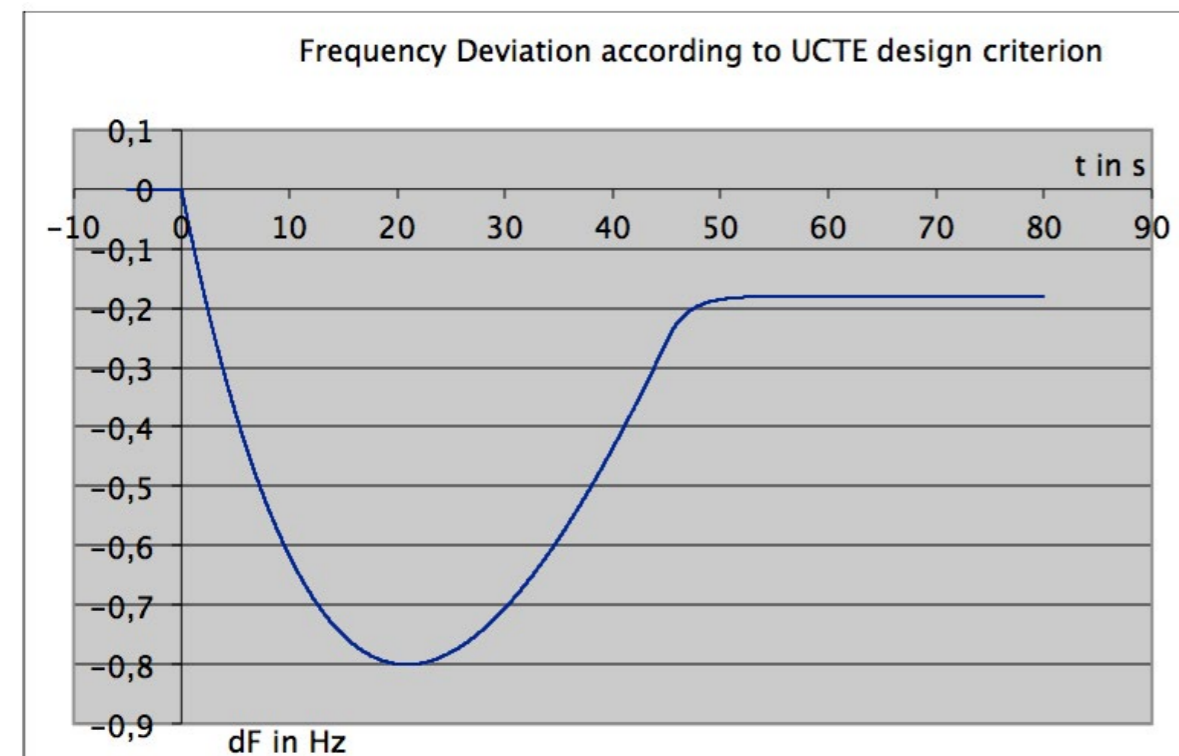

Figure 3: Frequency behaviour in case of a large power plant outage in the ENTSO-E network.

Frequency stability issues may occur in different time frames ranging from a few seconds (inertia problems) to several minutes (load following reserve/tertiary reserve) or even hours (back-up reserve):

- Few seconds: Transient frequency drop defined by system inertia and speed of primary frequency response.
Potential issues:
 - System inertia too low, initial frequency drop too fast
 - Response time of primary control too slow.
 Contribution:
 - All synchronous and (directly coupled) asynchronous generators (and motors) in the system.
- 10-30 seconds: Steady state frequency deviation defined by the primary control of the system.
Potential issues:
 - Insufficient primary reserve
 - Activation time of primary reserve too slow
 Contribution:
 - All primary controlled generators in the system (usually contracted)
- 5 min.-15 min.: Frequency back to nominal frequency, area exchange according to schedule.
Potential issues:
 - Insufficient secondary reserve
 - Activation time of secondary reserve too slow
 Contribution:
 - (Mainly) Secondary controlled generators in the area, in which the disturbance has occurred (usually contracted, controlled by AGC)
- 15 min. – 1h: Regulatory Reserve (spinning, also named “load following reserve” or “tertiary reserve”). Activation is manual or by AGC, no frequency response.
Potential issues:
 - Insufficient reserve
 - Activation time too slow
 Contribution:
 - All generators contracted for this service
- >1h: Back-up reserve (typically stand-by). Activation is manual by generators, or market-re-trading)
Potential issues:
 - Insufficient reserve
 - Activation time too slow
 Contribution:
 - All generators contracted for this service

It needs to be pointed out that the relevant terms and time frames differ from region to region. Whereas the terms “secondary control” and “tertiary control” are standardized and used in the European systems, the distinction between these two time frames is less stringent in many other regions and both is within the responsibility of the Automatic Generation Control (AGC).

In many developing and emerging countries there is no AGC (or automatic secondary control) in place and frequency control in these time frames is a manual task of the system operator.

Frequency stability problems can occur in the following situations:

- Loss of a large generator, total generator outage larger than primary or secondary reserve.
Consequences:
 - Low frequency problem
 - Disconnection of load (underfrequency load shedding)
- Disconnection of a large load -> high frequency problem, maybe leading to overfrequency disconnection of generation and sometimes a subsequent low frequency problem.
 - High frequency problem
 - Disconnection (or output reduction) of generation
- Deviation between load forecast and actual load larger than available load following reserve:
 - Disconnection of load (manual disconnection)

Because frequency is a very reliable indicator of active power balance problems, frequency stability issues can usually be resolved reasonably well by either disconnecting load or reduced generation.

In many cases frequency instability is just a consequential problem resulting from a system split caused by another stability problem (e.g. loss of synchronism between two areas). In these cases, the balance between active power generation and consumption is usually disturbed in both remaining areas.

TECHNOLOGY

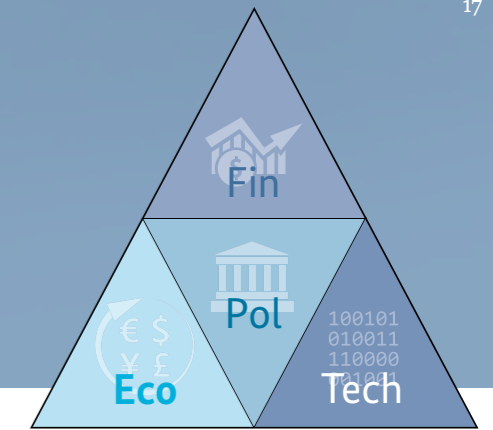

2.3.2 Voltage Stability

Voltage is the parameter in a power system that indicates whether there is a reactive power imbalance in an area of a system. In contrast to frequency, voltage can vary considerably between different bus bars. Hence, there are local and global voltage stability problems in power systems caused by small or large disturbances.

Voltage stability can be further distinguished as follows:

- Long-term voltage stability: “Chain reaction” resulting from overloaded branches, tap-actions of transformers etc. (“cascading faults”). Develops in the time frame of several minutes up to hours and is usually of a global nature (“Voltage collapse”).
- Short-term voltage stability: Loss of voltage stability in the short-term, e.g. subsequent to a line trip or generator outage. Short-term voltage instability develops in the time frame of hundreds of milliseconds up to a few seconds.
- Dynamic voltage stability (“induction machine instability”): During voltage sags, induction generators accelerate and induction motors decelerate, both approaching their stalling point. When operating close to the stalling point, induction machines absorb a much higher amount of reactive power than prior to the disturbance. Consequently, induction machines can have a negative impact on voltage recovery in a system or even initiate local voltage instability.

Dynamic voltage instability develops in the time frame of seconds. Therefore it represents a special type of short-term voltage instability.

2.3.2.1 Long Term Voltage Stability

Long-term voltage collapse typical develops in a time frame of minutes to hours. In many situations, a voltage stability problem occurs as a consequence of the sudden disconnection of a large generator under high import conditions into an area. In case of such an event, the following sequence could lead to a voltage collapse: As a consequence of a disturbance, the voltage initially drops whereby reactive demand in the area will also

reduce because loads are voltage dependent. However, in the longer term, within several minutes, the transformers supplying distribution grids will try to increase the voltage at their LV-side by adjusting their on-load tap-changers and consequently start increasing reactive demand in the system again. At the same time, over-excitation limiters of synchronous generators limit the reactive power generation in the problematic area. Altogether, this might lead to a reactive power deficit in the problematic area or exceeds voltage stability limits of long transmission lines connecting the problematic area with other areas. As a consequence, voltage starts reducing and finally collapses.

In contrast to a frequency stability problem, it is difficult to detect voltage instability and therefore, it very often happens that load is not shed and stays connected until the voltage finally collapses (when it is too late). The identification of a risk of voltage collapse is still a research topic and automatic defence strategies against voltage collapse is still a field that is under research.

2.3.2.2 Short Term Voltage Stability

In principle, short term voltage stability is based on the same physical effects as long-term voltage stability, with the exception that it results from reactive power deficits or excess of active power transfers in the time frame of several seconds (and not minutes). In contrast to long-term voltage stability, the time during which short-term voltage stability develops is linked to the time constants of fast controlling devices, such as SVCs (Static Var Compensators) or even controllers of wind generators.

In Figure 4 it is shown how voltage and frequency develop in case of a large generator outage leading to a short-term voltage collapse. As it can be seen in these figures, the system is not able to re-establish the reactive power balance in the short term leading to a sudden decrease of the voltage and finally to loss of synchronism. Frequency however looks relatively healthy until the system finally loses synchronism.

In this particular case, the dynamic range of available SVCs in the system was insufficient. As a result, the relevant SVCs hit their reactive capability limits leading to a reactive power deficit in the short-term and finally to a voltage collapse. In the long term however, when only

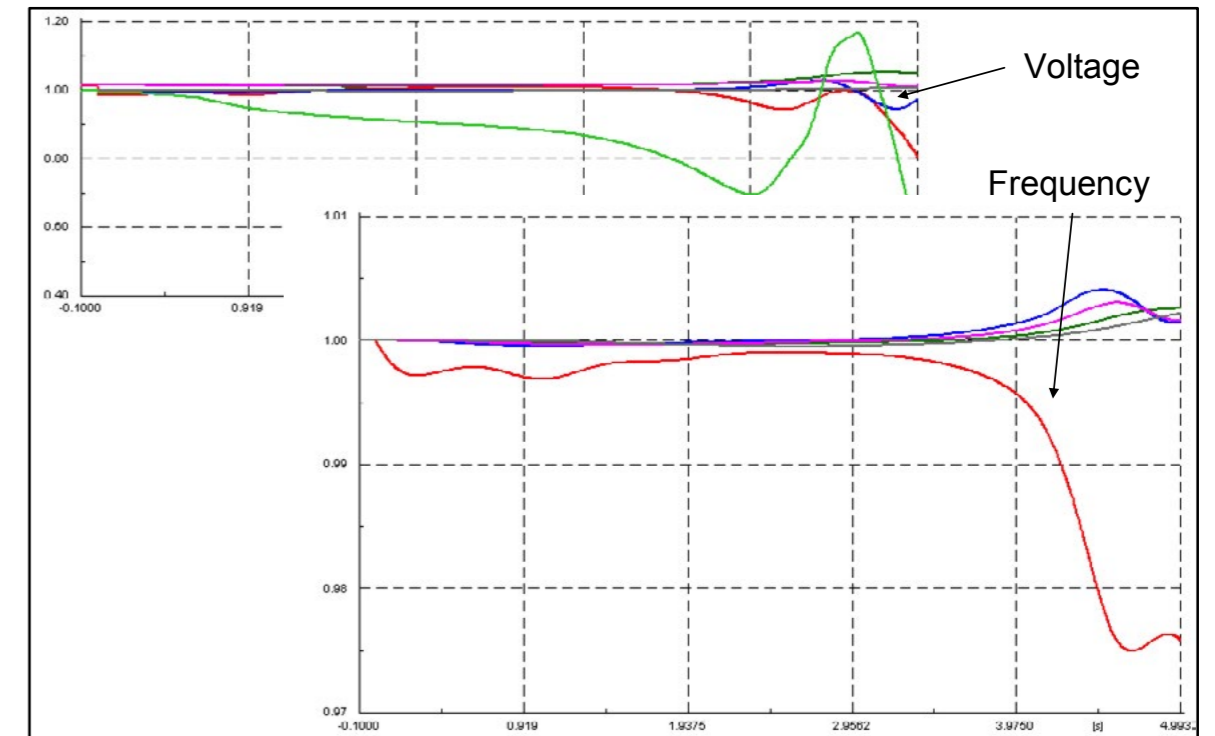

Figure 4: Voltage and frequency subsequent to a large generator outage leading to short-term voltage collapse

studying the post-contingency steady state, no problem would be observed in this particular case because of mechanically switched capacitor banks (MSCs) that could be made available within several minutes providing the additionally required reactive power reserve. However, this is irrelevant in this particular case because stability would be lost long before any additional capacitor bank could be connected to the system.

As this example shows, it can never be fully predicted if long-term or short-term voltage stability is more critical. For being able to better predict which of the two aspects might be more critical, an evaluation according to Table 1 can be carried out, in which every positive effect is shown in green and every negative effect is shown in red.

According to Table 1 the following statements can be made:

	Short-Term	Long-Term
Q- contribution of synchronous gen.	Large (thermal overload capabilities)	Limited by overexcitation limiters
Switchable shunts	No contribution (switching times too high)	High contribution
SVC/TSC	High contribution	High contribution

Table 1: Contribution on short-term and long-term voltage stability

- In systems or areas, in which reactive power is mainly provided by synchronous generators, long-term voltage stability will be more critical because the reactive range of synchronous generators is substantially larger in the short time than in the long time, where over-excitation limiters start getting active.

TECHNOLOGY

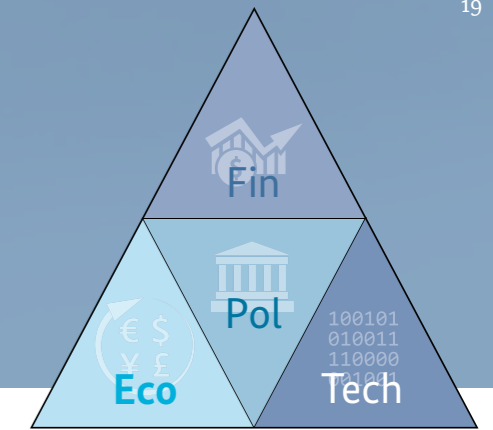

- In systems, in which MSCs contribute highly to the reactive power balance, short-term aspects might be more critical, because their contribution to the reactive power balance can only be made available in the longer term.

In addition to the above aspects, the influence of on-load transformer tap changers on reactive demand must be considered: Because of tap action, reactive demand is higher in the long term than in the short term.

2.3.3 Rotor Angle Stability

2.3.3.1 Oscillatory Stability

Synchronous machines tend to swing against each other in the case of even small disturbances. For mitigating this phenomenon, directly coupled synchronous generators are equipped with damping windings and in many cases with additional Power System Stabilizers (PSS), which are control devices that modulate the excitation voltage for improving system damping.

However, especially in the lower frequency domain, in which inter-area oscillations are relevant, it is not possible to fully attenuate power oscillations with the above described mitigation measures.

Here, power oscillation dampers (PODs) can be applied, which are control devices that are connected to Static Var Compensators (SVCs) and which modulate the voltage for improving system damping through the voltage dependence of loads.

Inter-area power oscillations become worse in the case of high power transfers across long tie-lines connecting different areas. In the case that power transfers up to the thermal limit of a transmission line would lead to oscillatory stability problems, power transfers have to be limited for ensuring that a minimum damping of inter-area oscillations is maintained during the operation of the system (stability constraint transfer limit)

In the case that damping gets below a minimum required value or if damping even becomes negative (oscillation with increasing amplitude) system security is heavily endangered. Such a situation will finally lead to loss of synchronism between interconnected areas and con-

sequently to a split of the system into several islands leading to subsequent frequency stability problems. Because oscillatory stability is a small disturbance phenomenon, it is independent from the type of disturbance. Hence, in the case that an undamped mode exists, even the smallest variation can excite it.

Besides rotor angle issues, oscillatory stability phenomena can also be caused by incorrectly tuned governors. However, in these cases it's frequency that oscillates, not rotor angles. Hence, strictly spoken, these oscillations are frequency stability phenomena. Corresponding oscillatory modes are often classified as "governor mode".

2.3.3.2 Transient Stability

Transient stability describes the ability of a power system to maintain in synchronism following large disturbances, such as grid faults. Because of the nonlinear nature of power systems, transient stability depends not only on system properties but also on the type of disturbance. The main aspects, on which stable or unstable behaviour depends, are:

- System characteristics (topology, line lengths, etc.)
- Operating conditions
- Fault type and location
- Fault duration

Because of the complexity of the problem, transient stability can only be analysed by a series of time domain simulations using dynamic models of generators, governors and controllers.

Local transient stability refers to the ability of an individual synchronous generator to remain in synchronism following a solid 3-phase grid fault that is cleared within the maximum permitted first-zone protection clearing time (e.g. 150ms) under worst-case operating conditions (e.g. lowest possible short circuit level at connection point, maximum power production of the generator). Inter-area transient stability issues can occur during high export situations of an area. For ensuring that critical fault clearing times remain above minimum required limits (e.g. 150ms) active power transfer limits may be imposed.

2.3.4 Relationship between different stability phenomena

Even if the classification of different stability phenomena is widely accepted nowadays, it would be a mistake to analyse the different stability phenomena separately from each other.

Especially in the case of heavy disturbances, cascading effects may occur and one stability phenomenon can cause a different-one or several types of stability phenomena may coexist simultaneously.

For example, the ENTSO-E brown-out in November 2006 started by the disconnection of a transmission line that caused consequential trips of other lines because of overload (cascading faults).

Because of the reduced transmission capacity, an Inter-Area-Oscillation with negative damping was initiated. This unstable oscillation finally resulted in a split of the Continental European system and active power imbalance in the remaining areas resulting in either underfrequency or overfrequency problems. The final result was heavy load disconnection because of underfrequency.

Other large disturbances, like the black out in Italy in 2003 started from overloaded lines (between Switzerland and Italy) and low reactive power reserves in the Italian system. This caused a voltage collapse, which finally led to the disconnection of the entire Italian transmission system.

3 Impact of Renewable Generation on Power System Reliability and Security

3.1 General

The main differences between Variable Renewable Generators and Conventional Generators are the following:

- The dispatch of Renewable Generators can usually not be planned (only predicted) because of the variable nature of the primary energy (wind, sun, etc.).
- Wind farms have to be built at sites with strong winds. Therefore the location of wind farms cannot be chosen and the grid has to be re-structured accordingly.
- Many Renewable Generation technologies (e.g. wind and PV) use different generator types than Conventional Generators (“static” generators based on power electronics converters,

no coupling between electrical frequency and mechanical speed).

- In most cases Renewable Generators are rather connected to distribution levels and not to main transmission levels (embedded/distributed generation).

Each of these aspects can have different impact on one or more of the Security and Stability aspects described in section 2.

Besides this, Renewable Generation can only have a considerable impact on system-wide aspects if their penetration level is considerable high. In some cases, a regional high penetration level is sufficient for causing a stability problem, in other cases a considerable impact can only be noticed if the system-wide penetration level is sufficiently high.

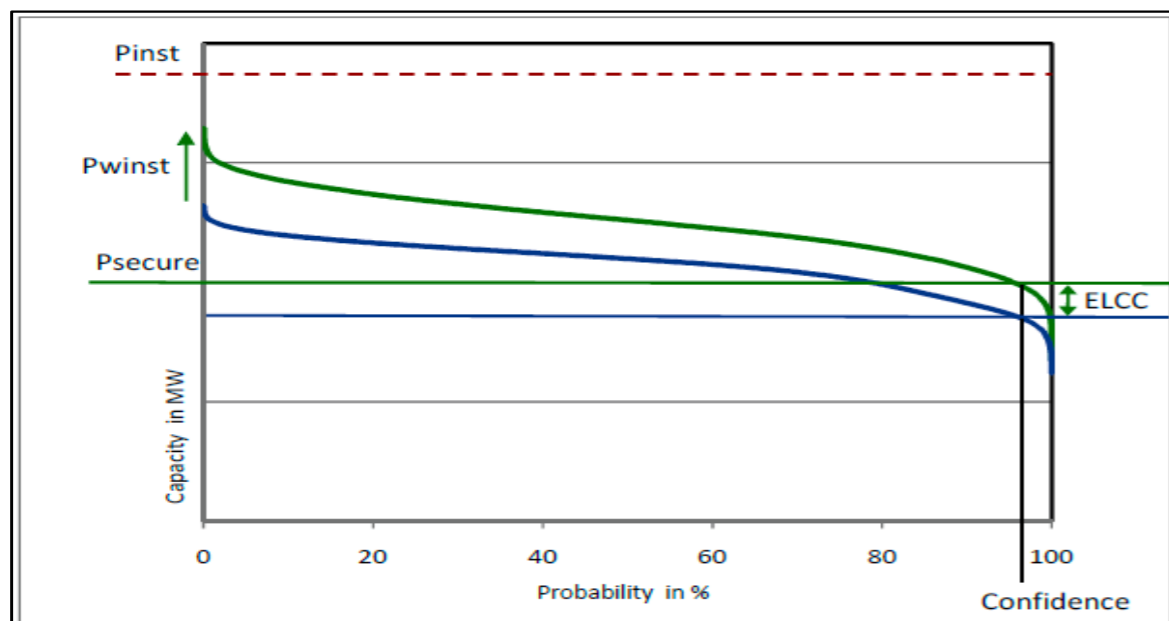
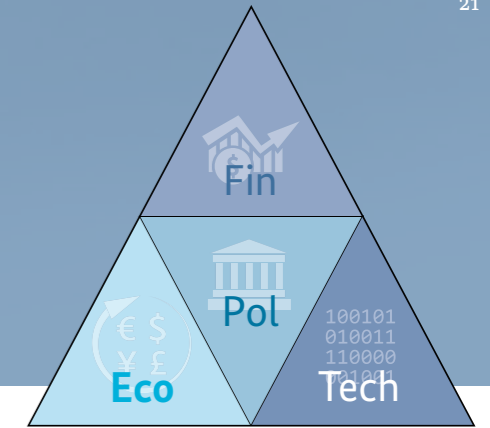

Figure 5: Definition of ELCC at a given confidence level



3.2 Reliability

3.2.1 Generation Adequacy

As described in section 2.1.1, generation adequacy relates to the reliability of generation in the long run and is expressed by reliability indices, such as LOLP, LOLE or ENS (see section 2.1.1).

Generally, when adding generation (variable or dispatchable) to a system, generation reliability will improve or at least remain unchanged. Figure 5 shows the cumulative probability curve of available generation in a system. The y-axis values show the generation capacity, which is (at least) available at the corresponding probability, which represents the x-axis value.

In the example according to Figure 5 the horizontal blue line is equivalent to the capacity that is available with a probability of e.g. 95% (or “Confidence” in Figure 5), without considering variable generation. The green line shows the available capacity, when considering both conventional and variable generation at the same time. Because generation is added to the system (even generation with low availability), the green line will almost be above the blue line (and never below), and hence, the capacity that will be available at the given confidence level increases.

The increase of the available capacity at a given confidence level is also named ELCC (Equivalent Load Carrying Capacity) of variable generation. ELCC represents a good measure for the contribution of variable generation to the “firm” capacity of a system and is the most common concept for quantifying Capacity Credit of Variable Generation (see also [2], [3] and [4]). The actual Capacity Credit of Variable Generation depends mainly on:

- Average production
- Diurnal correlation between variable generation and load
- Seasonal correlation between variable generation and load
- Correlation of variable generation at different sites.
- Variable generation penetration levels
- Seasonal correlation between variable genera-

tion and hydro generation (e.g. in regions with dry and humid season)

- Availability and distribution of conventional (thermal and hydro) power plants

Because these aspects are heavily site and technology-specific it is extremely difficult to provide typical values for the capacity credit of wind or PV generation and it is required to carry out capacity credit studies considering credible scenarios for the development of variable generation.

Corresponding studies for the Mexican and South African power systems [5] and [6] found capacity credit values between 20% and 25% depending on wind farm sites and penetration levels. The German DENA-study [7] identifies capacity credit values more in a range between 10% and 15% depending on the year and the penetration of wind energy.

3.3 System Security

3.3.1 Reserve Allocation

For safely operating a power system it is required to allocate sufficient operational power reserve during all times.

Operational reserve is required for:

- Compensating the error between scheduled and actual generation (load following reserve).
- Compensating the unexpected loss of a generator.
- Compensating sudden load disconnection.
- Insufficient operational reserve would lead to subsequent frequency stability problems (frequency rise or frequency drop, see section 3.4.1) and consequently to load disconnection.

For covering the different time frames, in which active power reserves will be required, different reserve products are defined and (in liberalized electricity markets) traded as ancillary services:

- Short term (primary and secondary reserve, see section 2.3.1)
- Medium to long term (tertiary reserve, back-up reserve, etc.)

TECHNOLOGY

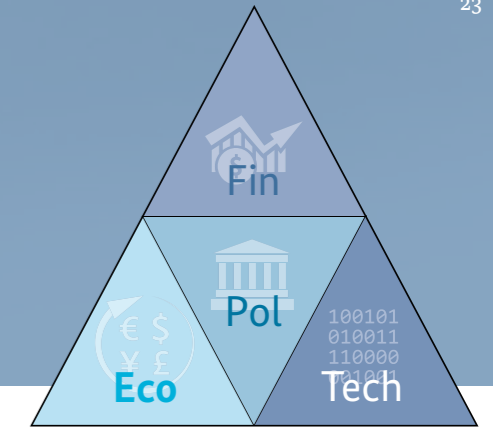

Short-term reserve has to be kept as “Spinning Reserve” whereas longer term reserve can either be spinning or stand-by reserve depending on technology and activation time.

In the short term (time frame <15 minutes), the total amount of wind and solar generation is relatively constant. Therefore the amount of required reserve mainly depends on worst case assumptions with regard to large, unplanned power plant outages and not on variability of wind and sun. For more details, please refer to the frequency stability section 3.4.1.

However, it has to be noted that despite the fact that the overall amount of primary and secondary power reserve is not considerably influenced by wind and solar generation, the required primary and secondary reserve has to be delivered by less conventional power plants in the system. This means that required primary and secondary power reserve on a “per unit” basis is increasing, even if the total amount of required reserve remains (almost) unchanged.

In the longer time frame however (>15 minutes), wind and PV generation have considerable impact

on the amount of required medium to long term reserve power because of the variability and the limited predictability of wind speed and solar irradiation. In systems without a considerable share of wind and PV generation, operational reserve has to balance the mismatch between predicted and actual load. In a system with a considerable share of Variable Renewable Generation (wind and PV) however, it's the variation of the Residual Load that has to be balanced by operational reserve (see also section 4.2.1.2).

The Residual Load is defined as being the Actual Load minus Variable Generation. Finally, it's the Residual Load instead of the Actual Load that Conventional Power Plants have to supply in a system with a large share of Variable Generation.

Hence, it's not the actual variability of wind and PV generation that has the main influence on the additional amount of required operational reserve but the accuracy of wind and solar prediction. Because the predictability of wind generation is less accurate than the load forecast, the required amount of additionally required operational reserve is increasing with increasing Variable Renewable Generation.

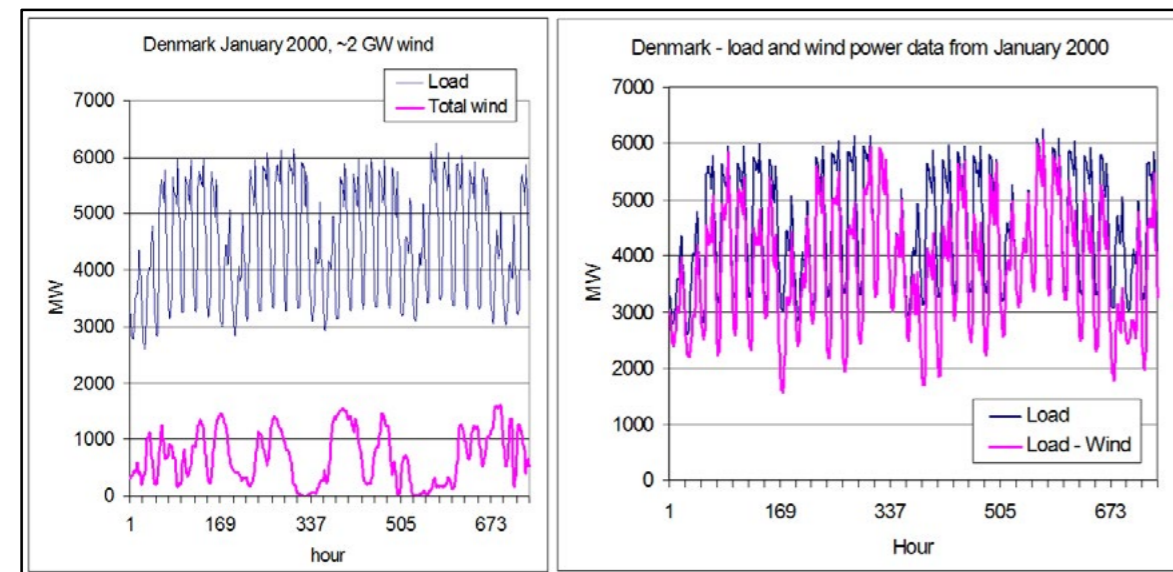

Figure 6: Load, wind generation and Residual Load (Load minus Wind Generation) [8]

Consequently, the implementation of accurate wind and solar forecast tools is essential for efficiently operating a power system with a high share of Variable Renewable Generation.

3.3.2 Grid Congestions

3.3.2.1 Wind Generation

In most cases, wind resources are relatively far away from load centres. Consequently, the integration of large amounts of wind generation will modify power flows in the power transmission grid considerably. Therefore, wind generation can cause grid congestions or will require additional transmission lines for resolving these congestions.

Because of the variability of wind, additional transmission lines may only be required for few hours per year and sometimes are not economically feasible. In other cases, the procedures for building new lines can take far more time than the installation of wind parks causing the problems and congestions resulting from wind generation have to be managed by the system operators.

With the help of the following tools, the implications of grid congestions can be reduced without having to curtail wind generation during all times of operation:

- Automatic inter-trip or run-back schemes (especially in the case of local correlation between wind generation and grid congestions)
- Dynamic line rating systems
- Wind forecast tools supporting the generation of load flow cases for day-ahead or intra-day congestion management.

3.3.2.2 Solar Generation

3.3.2.2.1 Decentralized PV-generation (solar rooftop systems)

Rooftop-PV-systems are feeding into low voltage distribution networks and predominantly impact voltage

and thermal loadings of LV-feeders.

Because LV and MV networks are (in >90% of all cases) operated radially (with open points), thermal overloading and the violation of maximum and minimum voltage limits can be predicted at the planning stage and shouldn't be resolved at operational time scales. Because LV lines and cables are predominantly resistive, active power injections have a direct impact on voltage (in contrast to HV-networks with high X/R ratios, where voltage magnitude predominantly depends on reactive power flows and not on active power flows). Therefore, voltage variation is the dominant problem in LV-networks with high penetration of embedded PV generation.

For mitigating voltage problems in LV networks caused by large amounts of rooftop PV generation, the following options exist:

- Use of MV-LV transformers with on-load tap changers.
- Power factor control of PV-inverters.
- The first option, MV/LV transformers with on-load tap changers is by far more efficient than the use of power factor control in LV networks. Because of the resistive nature of LV grids, reactive power only has a minor influence on voltages and therefore, power factor control can only slightly mitigate voltage problems in these networks. Besides this, increased reactive power flows on resistive lines and cables increase losses considerably.

On the other hand, large voltage increases only have to be expected in LV-networks with very high rooftop PV penetration (higher than the load). In most countries the injection of electricity generated by rooftop PV is remunerated by a Net-Metering Scheme, which makes the own-consumption of generated PV-electricity by far more profitable than energy delivery to the grid. Therefore, very large sizes of rooftop PV installations, as it is known from Germany, does not have to be expected in these countries and therefore excessive voltage problems don't have to be expected neither.

TECHNOLOGY

3.3.2.2.2 Large PV plants

In the case of large, utility-scale PV plants, similar issues have to be considered as in case of wind generation (see section 3.3.2.1).

However, in many regions, the predictability of solar generation is much more reliable than wind prediction, which improves the management of grid congestions.

3.3.2.2.3 CSP plants

In contrast to wind or PV generation a CSP power plant has in most cases a considerable storage capacity of several hours (through a thermal storage system, e.g. on basis of melted salt).

Such a storage system increases the predictability of solar generation and improves the management of potential grid congestions.

3.4 Impact on System Stability

3.4.1 Impact on Short-Term Frequency Stability

3.4.1.1 Inertia (Time Frame: few seconds)

Wind and PV inverters don't have a direct impact on system inertia because variable speed wind generators and PV-inverters are "inertia-less" generators, meaning that they don't have any inertia (PV-inverters) or that the corresponding inertia is de-coupled from the grid (variable speed wind generators) and won't release any energy to the grid in the case of frequency drops.

However, during times of high wind or solar generation, wind and PV generation may replace synchronous generation. Hence, inertia-less generation replaces generation that contributes to system inertia. Consequently, system inertia drops during times of high wind and PV generation leading to faster frequency drops (or rises) in the case of a sudden generation deficit (respectively surplus), as it may occur in the case that a large generator is suddenly disconnected from the system or that an area of the system that operates under heavy import or export conditions

is suddenly disconnected from the rest of the system and starts operating as an island.

There are new developments in the area of wind generation trying to make the energy stored in the inertia of a wind turbine available to the system in the case of frequency drops (e.g. "artificial inertia"). However, because of the aerodynamic characteristics of a wind turbine, there is always the risk that a wind turbine is driven out of the optimum point of operation and hence that an increased power output (due to a frequency drop) is followed by an active power drop because of aerodynamic effects caused by the speed reduction.

For this reason, "artificial inertia" can generally not be recommended as a tool for overcoming inertia problems of a system with large share of wind and PV generation.

3.4.1.2 Primary Control

The amount of primary control reserve that has to be preserved is usually linked to the largest units of a system. If the outage of the largest generating unit of a system should not lead to any load disconnection, sufficient primary control reserve power must be allocated for compensating this event.

However, in many parts of the world, especially in developing and emerging countries, the largest generating units are not fully backed up by primary reserve power for economic reasons. Consequently, the loss of the largest unit would lead to load shedding due to underfrequency.

Primary control reserve power must be activated within a few seconds and must be made available to the system until the secondary control reserve has been fully activated (typically 5 minutes).

Within this time frame, system wide wind fluctuations or solar variations can almost be neglected. On a system-wide level, only average wind speeds are relevant (wind turbulences are only local and not noticeable on a system-wide level). Since average wind speeds and solar variation don't vary considerably in the time

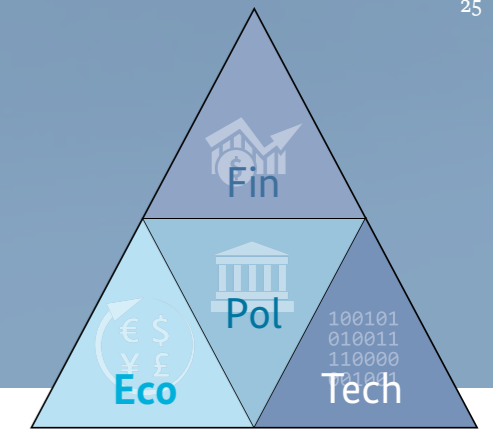

frame that is relevant for primary control, the impact of the fluctuating nature of wind and solar generation can usually be neglected.

Only in systems where the local concentration of wind and solar generation is very high (e.g. on islands), an impact of wind and solar variability on primary control reserve has to be expected.

In most systems, even in systems with high wind and solar penetration, wind and solar generators still don't contribute actively to primary frequency control (with the exception of a high frequency response, as it is required in Germany). Technically, it would be possible that wind and solar generation contributes to primary frequency control. However, as for every power plant, it is required to limit the power output of a wind or PV farm in order to enable primary control reserves. Because variable costs of wind and solar generators are virtually zero, it is always more economical to allocate active power reserves on conventional power plants and not on renewable plants.

Only in systems with very high penetration of wind and solar generation, it may happen that during times of very high wind and solar generation, the number of dispatched Conventional Power Plants is so low that it will be needed that wind and solar power plants provide active power reserve as well. In this case, a corresponding contribution, which is technically not a problem, will be required.

The above statements all apply to Renewable Generators without storage (e.g. wind and PV-plants). In the case of Renewable Generators with storage (e.g. thermal storage of a CSP plant), a contribution to primary reserve power would be possible without "wasting" energy because the required reserve power could be made available by the associated storage device. Hence, it is very likely that in the case that wind and solar penetration levels become extremely high, primary reserve power will still not be allocated directly on wind and PV-plants but that additional storage devices will be installed, only for the purpose of providing active power reserve to the system.

3.4.1.3 Secondary Control

The time frame relevant to secondary control is between 5 and 15 minutes. This time frame is longer than the relevant time frame for primary control and therefore it is less evident that the required amount of secondary control power is not influenced by the variability of wind and solar generation.

However, in most places, even in systems with high wind penetration, the amount of secondary control power is mostly unaffected by the variability of wind and solar generation.

All other aspects of the previous section related to primary control also apply to secondary control.

3.4.1.4 Longer Term Operational Reserve

In the time frame above >15minutes (regulatory reserve, load following/tertiary reserve), the variable nature and the limited predictability of wind and solar generation has considerable impact on the required active power reserve.

Besides the variability of wind and sun, the additionally required reserve will highly depend on the predictability of wind and solar generation and on the quality of the used wind and solar forecast tools. For more details about longer term operational reserve, please refer to section 3.3.1.

3.4.1.5 Frequency Stability and FRT-Capability

All statements of the preceding sections only apply when it can be assumed that there won't be any considerable disconnection of wind and PV generation caused by grid faults, hence that all generators will be equipped with FRT (Fault Ride-Through or Low Voltage Ride-Through / LVRT)-capability.

In the case that a substantial amount of wind or solar generators will be connected that are not able to ride

TECHNOLOGY

through voltage dips, a single line fault in the transmission grid (which is a frequently occurring event) can potentially lead to the disconnection of a large amount of generation and hence might increase the amount of generation that can be lost because of a single fault. Consequently, the connection of wind and PV-plants without LVRT capability should only be granted as long as the lost power resulting from a simultaneous disconnection of these generators doesn't exceed the largest existing generating unit in this system.

However, because LVRT-capability is a standard feature of modern wind and PV-inverters, it is recommended that all wind and PV-generators in a system will be equipped with LVRT-capability for ensuring frequency stability.

3.4.1.6 Frequency Stability – Summary

The variable nature of wind and solar generation has in most cases no considerable impact on frequency stability, including the time range up to secondary control time frames (15minutes).

Operational reserve in longer time frames is considerably affected by the variable nature of wind and solar generation and has to be increased.

However, the fact that modern variable speed wind generators and PV-inverters are "inertia-less" influences frequency stability considerably. The main impact can be summarized as follows:

- Reduced inertia leads to faster initial frequency rate of change and to deeper transient frequency drops. This is particularly relevant in the case of island networks or in the case that islanding of a part of a larger system represents a credible contingency.
- The total amount of additionally required primary and secondary control reserve remains usually unchanged (assuming that wind generators and solar inverters are equipped with LVRT-capability) because the worst-case event is defined by the largest generating unit and not

by wind or solar variability.

- The contribution of wind and solar generation to primary and secondary reserve is not economical because the variable cost of these generating technologies is almost equal to zero.
- Only in the case of very high penetration levels, when remaining conventional power plants can't cover the required primary and secondary control reserve, it will be necessary that also wind and solar generation contributes to it.

3.4.2 Impact on Voltage Stability

Generally, modern wind and PV generators have similar reactive power control capabilities as synchronous generators of large conventional power plants and are able to operate in reactive power control or voltage control, as required by the system operator.

However, because many large synchronous generators connected to main transmission levels will be disconnected during times of high wind and solar generation, their integration can still have negative impact on voltage stability:

- Reactive power cannot be transferred over long distances but must be made available locally. However, especially wind farms are very often located in remote areas (remote from load centres). For this reason, even if wind farms are able to deliver reactive power, it can't be made available at the location where it is actually needed.
- Many wind and PV generators are integrated into lower voltage levels than large conventional power plants. Typical voltage control concepts however are strictly based on a step-down concept, where step-down transformers regulate the voltage of the next lower voltage level, which means that reactive power balancing is only possible in the direction from higher to lower voltage levels. Therefore, reactive power capability of wind and PV generators integrated into subtransmission or distribution systems can typically not be made available to the main transmission levels.

However, these issues can typically be mitigated at moderate costs by installing additional reactive power

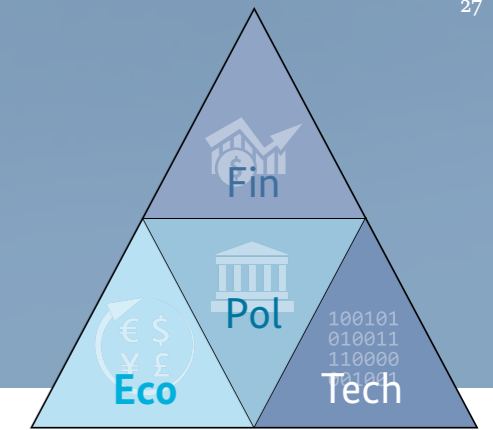

compensation, either based on switched capacitor banks (mechanical switched capacitors / MSCs) or static var compensators (SVCs). The required dynamic performance of additionally required reactive power sources must be identified by dynamic simulations looking at short-term voltage stability and transient stability aspects.

3.4.3 Impact on Transient Stability

Transient stability can be measured in terms of the critical fault clearing time. The critical fault clearing time is the maximum fault clearing time, for which all synchronous generators in a power system remain in synchronism.

For every power plant of considerable size, the impact of the new plant on critical fault clearing times has to be verified. It is required that critical fault clearing times are larger than the actual fault clearing times of the system assuming that faults in the HV transmission system are cleared within first protection clearing times. If this can be verified, transient instability won't have to be expected as long as protection operates according to the concept.

If, with the addition of a new power plant, critical fault clearing times increase, the impact of the new power plant is positive. If critical fault clearing times decrease and move closer to actual fault clearing times, the impact is negative. It might still be tolerable as long as critical fault clearing times remain above actual fault clearing times (e.g. 150ms).

Since wind and PV generators don't have a Transient Stability problem by themselves, their impact (positive or negative) on Critical Fault Clearing Times can only be indirect. An impact can result from one or a combination of the following aspects:

- Modified inertia in exporting areas (typically leading to improved Critical Fault Clearing Times)
- Increased line transfers, e.g. in the case that Renewable Generators are installed in exporting areas.
- Reduced voltage support during voltage recovery because of remote locations of RE plants or because Renewable Generators connected to distribution levels replace synchronous generators at main transmission levels.
- Reduced synchronizing torques between remaining synchronous generators.

Generally, the impact of wind and solar generators on Critical Fault Clearing Times can be both, positive or negative depending on which of the above aspects applies to the actual situation. Therefore, it is not possible to make a general statement about the impact of Renewable Generation on Critical Fault Clearing Times (positive/negative). The impact of Renewable Generation on Critical Fault Clearing Times must be studied in each individual case.

TECHNOLOGY

4 Study Approaches

4.1 Generation Adequacy Studies

4.1.1 Objective of Studies

Generation Adequacy studies are required as part of the generation expansion planning process. Sufficient generation adequacy ensures a sufficient level of reliability of supply. Time scales of Generation Adequacy studies are typical planning time scales ranging from one to several years.

When ignoring the contribution of variable generation to generation adequacy, the amount of conventional capacity that has to be installed will be overestimated. However, when overestimating Capacity Credit of renewable generation, there will be a risk of increased load disconnections because of generation inadequacy.

4.1.2 Methodology

Studies relating to the Capacity Credit of Variable Generation have to be executed on basis of defined scenarios for:

- Load growth
- Installation of variable generation plants (technology, site and size)
- Installation of conventional generation plants (technology and size)

These scenarios should clearly define expansion plans over several years.

For the actual calculation of Capacity Credit of Renewable Generation, there are basically two different approaches:

- Analytical approach (State Enumeration, Convolution)
- Monte Carlo simulation

Analytical Approaches are usually faster and lead to deterministic results. However they often work only under the following conditions:

- Random variables are stochastically independent (e.g. in the case of convolution approaches)
- The system can be described by a finite, discrete state space (which is not true in the case of variable generation, where the available capacity is continuous).

Hence, variable generation (and load) have to be approximated by a finite number of discrete states before they can be considered in a State Enumeration method.

The main advantages of analytical methods are:

- They can be very fast
- They lead to deterministic results

Monte-Carlo Methods are based on the simulation of random processes by using simple random generators. The main advantage of Monte-Carlo approaches are the following:

- Works with continuous random variables as well (no discretization of variable generation or load required).
- Consideration of any type of correlation is feasible
- Power measurements can be directly processed

Hence, compared to Analytical Methods, Monte-Carlo Methods are more flexible and don't require complicated pre-processing. On the other hand, their result is non-deterministic and in case of high accuracy requirements, calculation times can be substantial.

4.1.3 Data Requirements

Actual data requirements highly depend on the actual scope of studies and the expected accuracy of results. As a minimum set of required data, the following data can be defined:

- Technology and capacity of all conventional power plants
- Technology, capacity and location of variable generation plants
- Information related to load and tie-lines.

4.1.3.1 Conventional Power Plants

For conventional power plants, Forced and Planned Outage Rates are required as a minimum requirement. Forced Outage Rates (FOR) define the probability of unavailability of service because of unplanned outages (e.g. faults).

Planned Outage Rates define the probability of planned outages (e.g. because of maintenance). Some software packages are able to define an optimized maintenance schedule automatically, based on planned outage rates. Other software packages however require the definition of a deterministic maintenance schedule instead.

4.1.3.2 Variable Generation Plants

For considering variable generation plants, two modelling approaches are common:

- probabilistic modelling (e.g. based on Weibull-distribution functions in case of wind generation)
- Processing of measurement data

In the case of a probabilistic modelling approach, the consideration of correlation effects (either correlation between different variable generation plants or correlation between variable generation and load) is quite difficult to realize.

Some simulation packages offer limited choices here, e.g. by distinguishing either fully correlated plants or uncorrelated plants.

More realistically is the consideration of correlation effects, when actual measurement time series data of variable generation are used. However, it is important that measurements over a representative period of time (e.g. 10 or 20 years) will be used when referring to actual measurements.

In the case that only limited time periods are available (e.g. one or two years only), it is recommended to adjust the corresponding time series data to the long-term average of wind speed or solar irradiation so that at least average production is reflected correctly in the analysis.

4.1.3.3 Transmission Constraints and System Boundaries

The way in which transmission constraints should be considered for calculating generation adequacy or not is discussed quite extensively in literature (see e.g. [3]). Generally, the results of generation adequacy studies will depend on the system boundaries – the larger the system that is considered the higher will be the capacity credit of variable generation.

System boundaries should typically be considered on long tie-lines, where power flows are heavily restricted compared to flows inside the area surrounded by the boundary. The contribution of system imports to the Equivalent Firm Capacity of the system can be modelled by the capacity of the boundary lines and the availability of these lines.

In the case of interconnected systems consisting of many relatively small regions connected via long tie lines, it might sometimes be appropriate to calculate both, regional and system-wide capacity credit and to define the difference between the Equivalent Firm Capacity obtained for the system-wide analysis and the sum of the Equivalent Firm Capacity of all regional calculations as being the capacity credit of a stronger transmission grid.

4.2 System Security Assessment

4.2.1 Studies relating to the Impact of Variable Generation on Operational Reserve

4.2.1.1 Objective of Studies

The objective of studies relating to the impact of Variable Generation on Operational Reserve is the following:

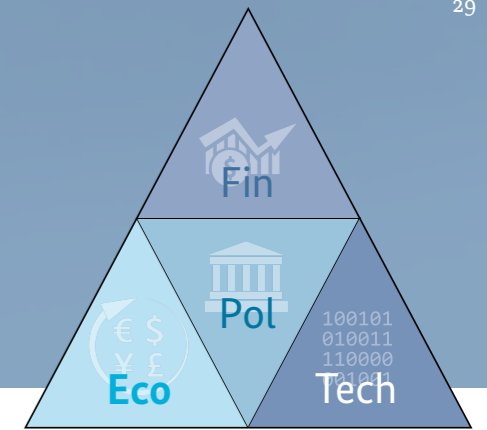

TECHNOLOGY

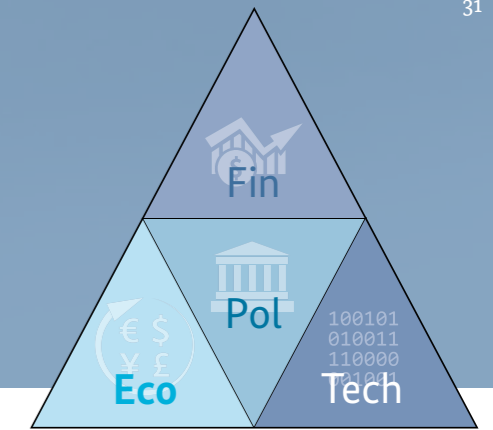

- Identify the impact of variable generation on maximum, minimum and average reserve requirements.
- Determine the impact of variable generation on dynamic performance requirements of conventional power plants.

4.2.1.2 Methodology

Studies relating to operational reserve requirements usually assess the Residual Load, which is defined as being the actual load minus variable generation and therefore represents the load that needs to be covered by conventional (dispatchable) generation.

By comparing the relevant characteristics of the Residual Load of a system with high penetration of variable generation with the relevant characteristics of the actual load, the impact of variable generation on operational reserve requirements of a system can be identified.

4.2.2 Steady State Security Assessment

4.2.2.1 Load flow and Contingency Analysis

For meshed networks, the verification whether the system is secure under “n-1”-conditions is the most widely applied system security study. The term “n-1” basically means that the system must continue to operate in the case that one component at the time fails.

In reality, a set of credible contingencies is usually analysed comprising:

- Single line failures
- Transformer failures
- Failures on reactive compensation equipment
- Loss of generators
- “Common mode” failures such as the simultaneous outage of two line circuits being connected to the same tower (e.g. because the tower construction fails)

For all analysed contingencies, thermal overloads on any network branch (lines, transformers) and any

violation of upper or lower voltage limits are automatically reported.

A system is considered to be n-1 secure if there is no such violation in any credible contingency.

Contingency analysis studies are carried out at planning levels and at operational levels.

At operational levels, contingency analysis is a standard part of any operational planning procedure. For the different operational planning time scales (e.g. one-week ahead, one-day ahead, intra-day etc.) contingency analysis studies are executed systematically for every hour per day (or in 4-hours intervals) for ensuring that the system will be secure during all times.

In the case that security problems are detected, system operators have to plan and execute mitigation measures, which are:

- Generator re-dispatch
- Switching of lines
- Switching of reactive power compensation devices
- Etc.

At planning levels, many system operators require n-2 security instead of n-1 security because planned outages (e.g. because of maintenance) have to be considered too. The requirement for an n-2 secure network is finally equivalent to a network, which is always n-1 secure if one element is on maintenance.

However, many transmission grids don't have the required degree of meshes for being able to be operated even in an n-1 secure manner.

4.2.2.2 Probabilistic Security Assessment

In systems with high penetration of variable generation, it becomes increasingly difficult to predict the relevant operational states one week-ahead or one day-ahead.

Therefore, system operators tend more and more to look at a larger variety of operational situations con-

sidering the uncertainty of the predicted generation level of variable generation.

The general procedure is then basically the same as in case of a deterministic security assessment but the amount of cases to be processed and the requirements for the speed of calculation of software and hardware become substantially higher.

4.3 Stability Studies

4.3.1 Short-Term Stability Studies

4.3.1.1 Study Methodology and Expected Results

Short-term stability studies analyse the time frame of a few seconds following a disturbance, such as a fault (short circuit) with subsequent disconnection of the faulted component, or the sudden disconnection of a power plant.

Short-term stability studies use a model that covers the time frame of a few seconds (e.g. up to 10 to 20 seconds after a disturbance).

With regard to the stability phenomena described in section 2.3, the following phenomena can be analysed using such a model:

- Oscillatory stability
- Transient stability
- Short-term voltage stability
- Short-term frequency stability

When carrying out studies relating to the impact of variable generation on short-term stability, the main steps are the following:

- Scenario definition: starting point are scenarios reflecting existing stability problems (e.g. high power transfers, etc.)
- Modify cases by considering merit-order dispatch rules, reduce and disconnect synchronous generators step by step until a new load – generator balance is found
- Execute studies for base case scenarios (without new variable generation)
- Execute studies for new scenarios considering

planned variable generation plants and analyse the resulting impact

4.3.1.2 Scenario Definition

With regard to the definition of scenarios, there are two different concepts that can be applied:

- Definition of a large number of scenarios reflecting various operational conditions (screening approach)
- Definition of worst-case scenarios for the analysis of specific stability phenomena
- The objective of a screening approach is to capture all credible operating conditions of a system and to analyse system stability for these scenarios.
- Screening studies are mainly applied in the case of large, meshed networks, in which the definition of worst-case scenarios based on the engineer's knowledge would be extremely difficult.
- The advantages of screening approaches are:
- A large number of studied scenarios allow evaluating the performance of a system for a large variety of credible operating conditions.
- No detailed system knowledge is required for scenario definition (as in case of an approach based on worst-case scenarios)

Studies based on screening approaches usually require automated post-processing of the results. Hence, the problem is usually to capture the right criteria for assessing and evaluating stability so that the result analysis can be automated.

In contrast to screening studies, studies based on worst-case scenarios try to assess the system's performance for credible worst case operating conditions. The advantages of the “worst-case” approach are:

- Precise definition of worst-cases. No risk to miss relevant situations.
- Low number of cases to be studied. These cases however can be studied in very detail.

The “worst-case” approach is the most commonly applied approach for stability studies. In most cases, it

TECHNOLOGY

is possible to define worst-case scenarios for analysing the various stability phenomena of a power system. However, the definition of worst-case scenarios requires lots of experience and engineering knowledge; otherwise, there is a high risk in not looking at relevant scenarios and missing relevant problems.

4.3.1.2.1 Definition of Worst-Case Scenarios for Stability Studies

Critical operation conditions for stability studies are typically operational conditions with:

- High power transfers over long lines
- Highly loaded generators

In the case of oscillatory and transient stability, high exports out of the area of investigation are generally representing worst case conditions.

However, in the case of voltage or frequency stability, high imports into the areas of investigation represent the most relevant operating condition.

When studying the impact of renewable generation on power system stability, new generator dispatch scenarios have to be specified under the consideration of new Power Park Modules. Because Power Park Modules do not become transiently instable by themselves, the chosen synchronous generators that will be disconnected with the addition of Power Park Modules will have a very high influence on the results and are therefore of very high importance. The typical procedure consists of disconnecting step by step synchronous generators with lowest merit-order until a new generation-load balance is established.

When “High-RE-Generation” scenarios are defined for systems with high RE penetration, additional spinning reserve requirements for balancing wind variations, possible grid congestions etc. have to be considered additionally.

4.3.1.3 Typical Short-Term Stability Studies

4.3.1.3.1 Transient Stability of one Power Plant (“FRT-Studies”)

The first type of studies, focusing on transient stability of a newly planned power plant is typically part of the scope of studies of every new power plant. Because only local stability properties are analysed here (transient stability of one power plant), this type of study is typically based on a highly reduced model of the transmission grid and a detailed dynamic model of the new power plant.

The minimum requirement is that a power plant is able to ride through any faults at HV transmission lines under the assumption that the fault is cleared by first zone protection. Hence, faults with duration of typically 120ms or 150ms are subject to these studies. According to most international grid codes applicable to wind and PV generation, the generators must be able to ride through faults in the system and at the grid connection point with a duration of up to 150ms (three-phase, two-phase, two-phase to ground, single-phase to ground faults).

In case of wind and PV generation, FRT requirements are typically defined by a voltage profile that shall reflect a minimum boundary of the voltage at the grid connection point, for which no disconnection is allowed.

Static inverters and generators controlled by static converters (e.g. doubly-fed induction generators) cannot become transiently instable in the classical sense of transient rotor angle stability. In variable speed wind generators, based on DFIG or fully rated converters the voltage angle is entirely decoupled from the mechanical system. In the case of PV-systems the inverter acts like an active/reactive current source showing a behaviour that is similar to wind generators with fully rated converter. This means that there is no “rotor angle”, which could show transient rotor angle instability.

Only when defining “transient stability” in a more general way, by “short-term stability following to large grid disturbance”, also variable speed wind generators

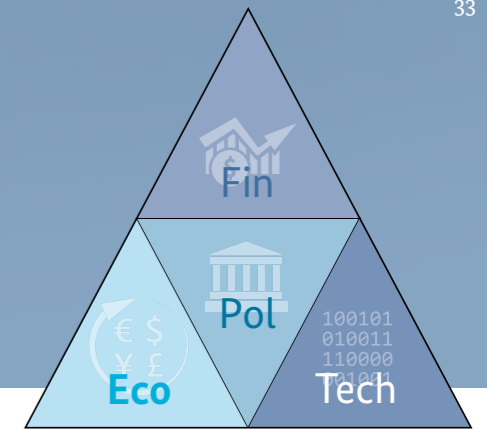

and PV-inverters may show stability problems in case of heavy grid faults that could lead to a sudden disconnection of the wind or PV-farm.

4.3.1.3.2 Verify the Impact on Critical Fault Clearing Times

Transient stability studies at planning levels only have to verify that Critical Fault Clearing Times are above Actual Fault Clearing times for ensuring that the planned system does not violate any transient stability constraint.

These studies simulate faults with maximum permitted fault clearing times at critical transmission lines for various operational scenarios and verify that no synchronous generator becomes instable in any of the simulated cases.

Transient stability studies looking at the impact of new generators in the shorter term (operational time scales,

<1 year) very often study the impact of new generation on Critical Fault Clearing Times in more detail.

In this case it is required to precisely calculate Critical Fault Clearing Times in the system for various operating conditions and to report on the impact that new generation may have, e.g. if Critical Fault Clearing Times become larger or smaller so that the risk of observing a transient stability problem increases.

4.3.1.3.3 Verify the Impact on Transient Stability Constraint Transfer Limits

Power transfers over long tie lines might be limited by transient stability aspects which might require active power limits that are below the thermal transfer capacity of the line.

In the example above (see Figure 7), critical fault clearing times of faults close to the tie line between the south-west area and the southern area will depend on

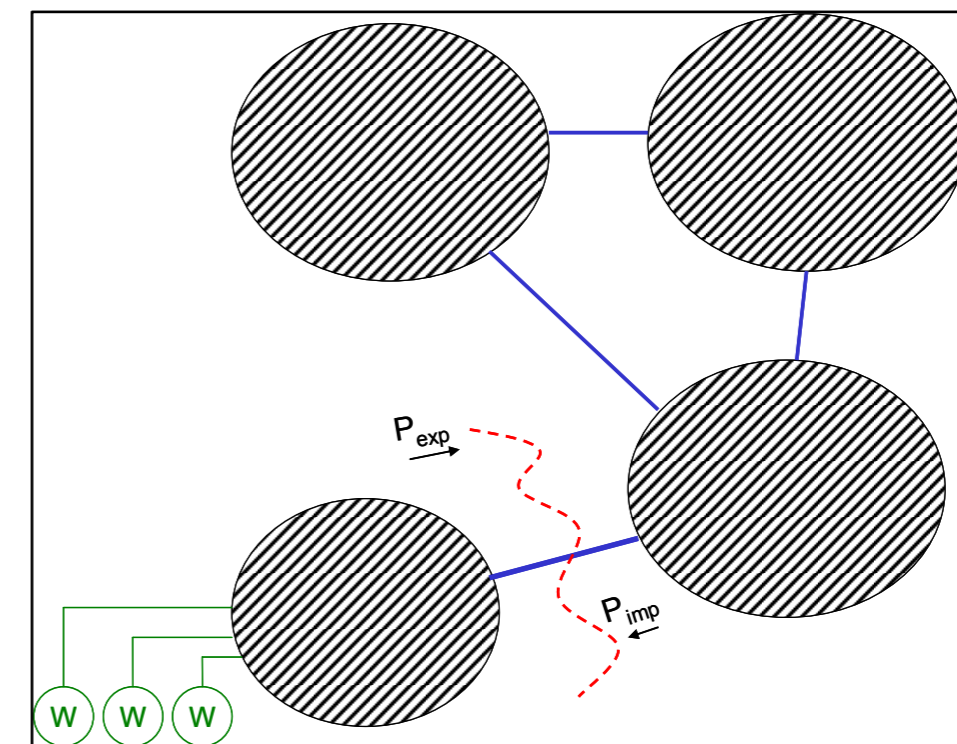

Figure 7: Interconnected Power System

TECHNOLOGY

power exports on that particular line. The higher these power exports, the lower critical fault clearing times will be. If the value of the power transfer, for which the critical fault clearing time drops below maximum permissible clearing time (e.g. 150ms), is below the thermal limit of the corresponding tie line, the export limit is not constraint by the thermal line rating but by transient stability aspects.

In systems, in which this type of problem is relevant, stability constraint export limits are determined by numerous transient stability studies and handed over to the control room engineers for consideration as an additional constraint in the generator dispatch.

4.3.1.3.4 Short-term voltage stability studies

In the system according to Figure 7, worst case situations with regard to voltage stability will occur in the case of high power imports (maximum value of Pimp). Assuming that the interconnection lines (“tie-lines”) are built by double circuits, the sudden loss of one of these circuits under high import conditions could lead to a voltage stability problem.

Alternatively, the sudden loss of a large generator inside the area of consideration could drive the power import to values above the short-term voltage stability limit, leading to a voltage collapse within a few seconds.

4.3.1.3.5 Frequency stability studies

The insertion of wind and PV generation (and the associated disconnection of synchronous generators) usually reduces the inertia of the system in the area of consideration. As long as this area is connected to a larger power system, frequency will be supported by synchronous machines outside the area of consideration and the reduced inertia is not relevant. However, if the sudden disconnection of the area with high renewable generation during high power imports represents a credible contingency, the initial frequency rate of change can be very high due to the low inertia and frequency may drop much more rapidly compared to a situation with large synchronous generation and may lead to a wide area disconnection of load in such a situation.

Therefore, the impact of wind and PV generation on short-term frequency stability can be relevant and needs to be studied, if the sudden islanding of an area with high penetration of wind and PV generation represents a credible contingency.

4.3.1.4 Data Requirements for Short-Term Stability Studies

Most transmission system operators maintain a dynamic model of their power system for the execution of short-term stability studies. These models are usually maintained in data formats of standard power system analysis software packages, such as PSS/E (Siemens) or PowerFactory (DIgSILENT GmbH) these models have to include the following:

- “Load flow” model containing all branch impedances, generators and loads
- Dynamic synchronous machine data
- Models of excitations systems, AVR (automatic voltage regulators) and PSS (power system stabilizers)
- Models of wind turbine generators and their controls
- Models of PV inverters

Models of synchronous generators, excitations systems, AVRs and PSS are standardized according to relevant IEEE standards (see [9]).

For standardizing models of wind turbine generators for short-term stability studies, an IEEE working group and an IEC working group is currently in place and it can be expected that suitable standards will be available soon.

Because not all actual controller types can be accurately mapped onto standardized IEEE-models, many TSOs maintain a library of user-defined, manufacturer-specific models of excitation systems, AVRs and power system stabilizers.

For frequency stability studies, the accurate modelling of turbines and governors (primary controllers) is required additionally.

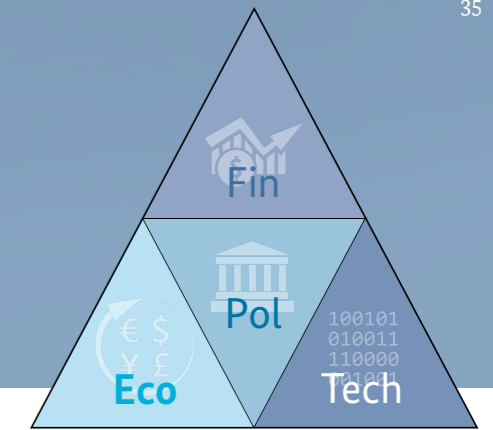

Many TSOs also maintain libraries of turbines and governors, especially TSOs whose systems are prone to frequency stability issues, but this is less common than dynamic models of generators, AVRs and power system stabilizers.

In many cases, the existing power system models do not include models of Variable Renewable Generation. Therefore, those models have to be added before being able to study the short-term stability impact of these generators.

However, when adding wind and PV generation to the system, conventional power plants have to be disconnected for balancing the load. Actually, the main impact on short-term stability is not resulting from the addition of wind and PV generation but from the disconnection of large, conventional power plants. Therefore, reasonable generator dispatch scenarios for situations with high wind and PV generation is essential for obtaining reasonable study results.

Depending on the application (operational issues or planning studies), either manufacturer-specific models of wind turbine generators and PV inverters have to be implemented or generic models of wind turbine generators (e.g. according to upcoming IEC and IEEE standards) can be used.

Besides the dynamic power system model, the following information should be requested from a TSO for executing a short-term stability study:

- Relevant faults (line faults, bus bar faults etc.) to be studied
- Maximum fault clearing times for which the system shall remain stable (e.g. in ENTSO-E: 150ms)
- Minimum damping requirements (in case of oscillatory stability problems)
- Merit-order list of conventional power plants (for being able to setup reasonable generator dispatch scenarios)
- Overview of known stability issues and operational scenarios, in which they occur (e.g. high transfer over a specific transmission line)

After having setup the model for the various operating conditions to be studied, including operational scenarios with high wind and PV generation, it is recommended to cross-check these scenarios with the TSO of the system to be studied.

4.3.2 Long-Term Stability Studies

4.3.2.1 Long-Term Voltage Stability Studies

For studying Long-Term Voltage Stability phenomena, there are basically two different possible approaches:

- Dynamic simulations using a long-term dynamic model
- Load flow simulations (PV-curves and/or QV-curves)

Dynamic models for long term stability studies require substantial enhancements to models for short-term studies only, e.g.

- Excitation limiters of AVRs
- Controllers of switched shunts
- Tap changer controllers

Only few system operators carry out long-term voltage stability studies using dynamic models and maintain a corresponding model.

Therefore and because of the high effort required for the implementation of such a model, it is common practice to study long-term voltage stability using a steady state, load flow based approach. Such a load flow model must also reflect the above listed limitations, especially:

- Excitation system limiters in the form of max. or min. reactive power limits
- Automatic tap control

but only for steady state operation. Load flow models considering maximum and minimum reactive power limits and automatic tap control procedures are usually available because those models are also required for contingency analysis studies (see section 4.2.2.1).

The basic idea of stability studies using steady state models is to identify whether a post-fault solution exists or not. Based on the outcome the following conclusions can be made:

- If no post-fault solution exists, it is evident that the system would become unstable
- If a post-fault solution exists, additional short-term stability studies would have to be carried out for identifying whether there might be short-term stability problems

Typical long-term voltage stability studies focus on one of the following aspect:

- Voltage stability constraint transfer limits over a long transmission corridor
- Required reactive power range of generation or load

4.3.2.1.1 PV-curves

The first type of problem is usually analysed by so called PV-analysis, in which the transfer over a critical transmission line is subsequently increased and the voltage against the relevant power transfer is traced. Such analysis is carried out for numerous contingencies, especially for contingencies relating to unplanned generator outages during high import situations.

The maximum power transfer is defined by the highest possible transfer while keeping all voltages above the required levels (under all contingencies).

The transfer over a relevant transmission corridor can be modified in two different ways:

- Shift of load from one area to the other (while keeping the total load and the generation dispatch constant)
- Shift of generation from one area to the other

A load shift can be made continuously by subsequently increasing load in the importing area and decreasing load in the exporting area (while keeping the total load constant).

Shift of generation is more difficult because generation is usually not continuously adjusted but dispatched e.g. according to a Merit Order table. Hence, a realistic shift of generation is usually fairly difficult to realize. In the case that the addition of renewables considerably decreases voltage stability constraint transfer limits, e.g. because reactive power reserves are reduced, possible mitigation can consist of additional reactive power compensation devices, such as switched shunt capacitors or SVCs.

The precise type of reactive power compensation device and its dynamic performance requirements have to be analysed by additional short-term voltage stability studies.

4.3.2.1.2 QV-curves

The purpose of QV-curves is to identify the required reactive power range of either conventional or renewable generators for ensuring voltage stability.

In the example according to Figure 8 a large number of wind farms (symbolized by green wind turbine symbols, e.g. several thousands of MW) shall be connected to a 500kV system via a double circuit line. For identifying the required amount of reactive power at the 500kV transfer node (see blue arrow in Figure 8), reactive power versus voltage will be traced for various relevant contingencies.

Theoretically, QV-curves would have to be traced for various active power levels of the wind farms. However, because it is known that maximum power transfer represents the worst case in this situation, QV-curves are only analysed for the case of maximum power output of the wind farms.

The resulting QV-curves are depicted in Figure 9. Each curve in this figure corresponds to a different contingency.

The behaviour of the system in the case of no voltage control at the relevant bus bar can be analysed by following the horizontal trajectories (constant Q). This means that in case of a line outage corresponding to the light blue line, the voltage would move from the black curve (base case) to the point on the light blue

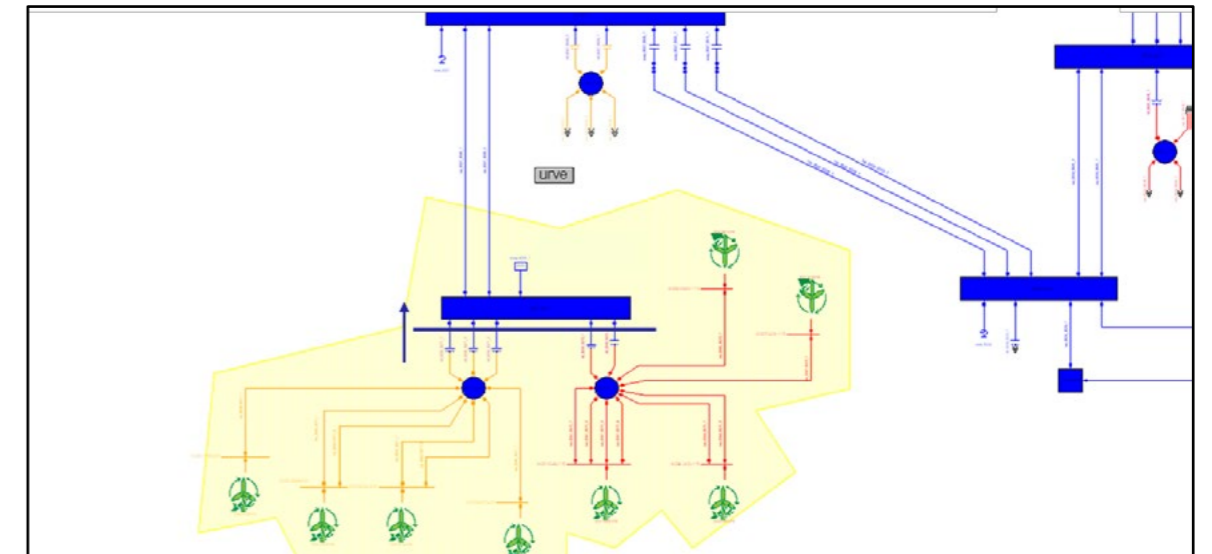
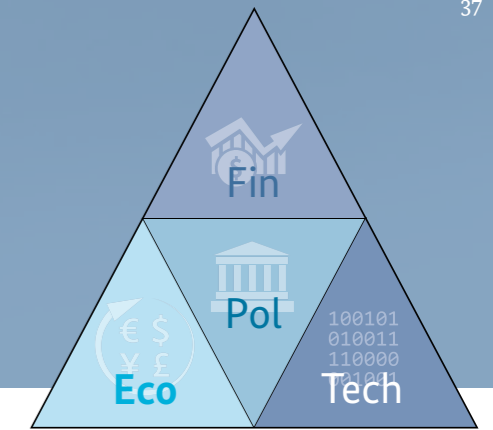

Figure 8 - Example for the connection of large wind farms to a transmission grid

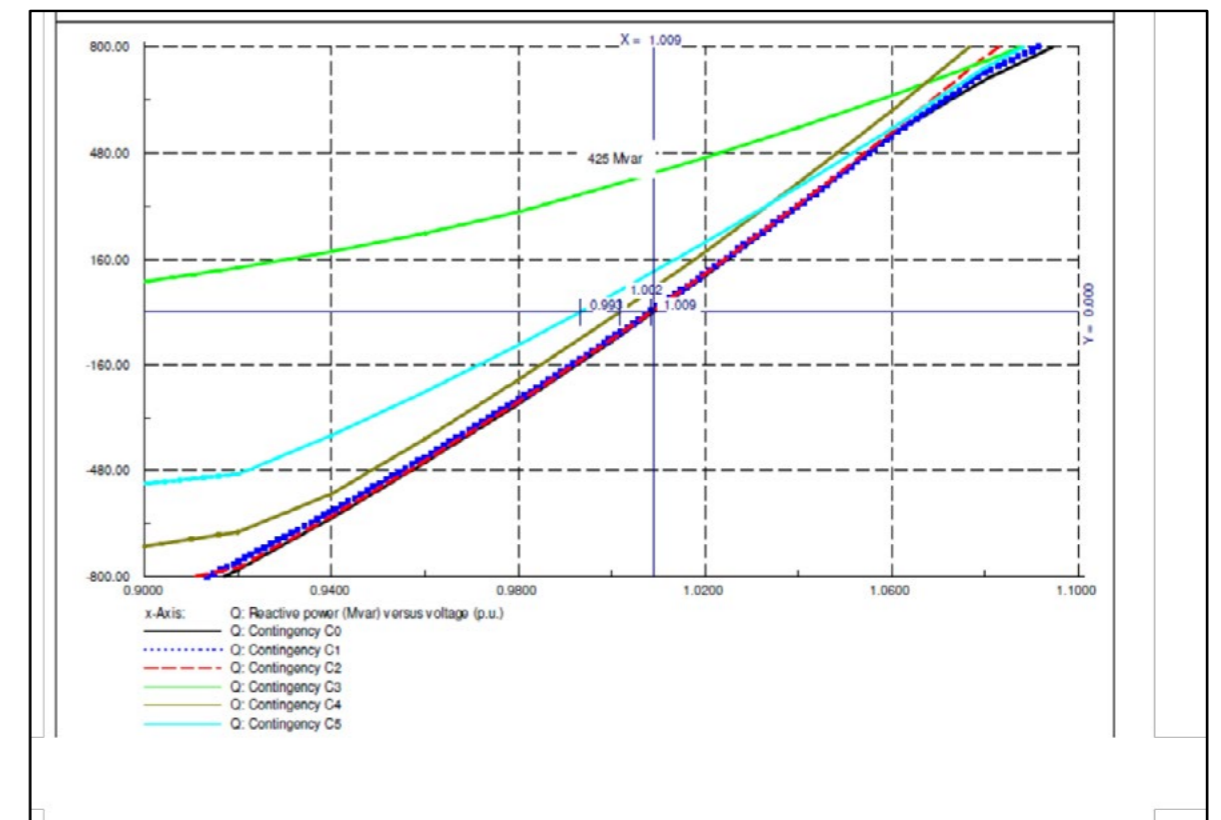

Figure 9 - QV-curves for various contingencies

TECHNOLOGY

line with $Q=0$. Hence, the resulting voltage step change would only be equal to around 1%.

However, in the case the line corresponding to the green curve trips (one of the two parallel circuits connecting the wind farms to the transmission grid), no post-fault solution could be found for voltages >0.9 p.u.

It could even be that the light green curve never crosses the line with $Q=0$ and starts going up again for low voltages. In this case no post-fault solution would exist at all and the system would run into a voltage collapse in case of a trip of one of the two line circuits connecting the wind farms to the transmission grid. This analysis shows that the installation of a proper feed-back voltage control is essential in this situation. When assuming that a voltage control system is installed, the vertical trajectories (constant voltage) have to be followed for analysing the system behaviour in case of a contingency.

As shown in Figure 9, the voltage control system would have to inject the additional amount of 425Mvar into the observed node for stabilizing the voltage in the case of the relevant contingency. The additional amount of 425Mvar could either be made available by the wind turbine generators or by a separate reactive power compensation device (SVC). For a proper design of the reactive power control system, additional studies looking at short-term stability effects would be necessary in addition to the QV-analysis.

4.3.2.2 Other Long-Term Stability Studies

Besides long-term voltage stability, other long-term stability effects could be relevant, especially long-term effects relating to frequency control (e.g. frequency oscillation because of badly tuned governors etc.). However, these studies are usually applied for analysing actual operational problems and are very specific so that no general recommendations for relevant study approaches can be given.

4.3.2.3 Data Requirements for Long-Term Voltage Stability Studies

Assuming that long-term voltage stability will be analysed on basis of steady state load flow studies (as described above), the following data are required:

- Load flow model, including all branch impedances, generators, load, shunt compensators
- Automatic tap changers (and their control setpoints and bands)
- Reactive power capability diagram of synchronous generators
- Reactive power capability diagram of renewable generators
- Control methods of switched compensation devices
- Description of typical post-fault actions executed by system operators
- In case of studies relating to voltage stability constraint transfer limits: guidelines for shifting load or generation (see section 4.3.2.1.1)

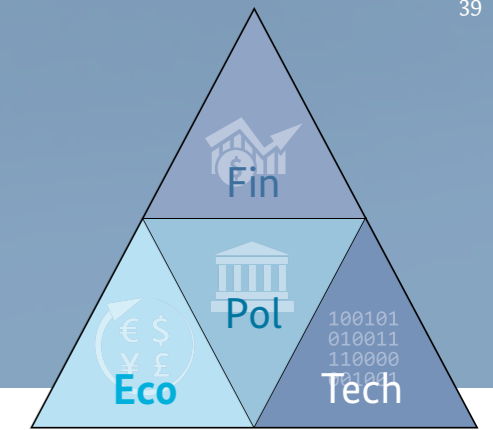

5 Summary

This report provides an overview about Reliability, Security and Stability phenomena in power systems, describes the impact of variable renewable generators on these phenomena and provides guidelines for study approaches and methodologies for analysing the impact of variable renewable generation of Reliability, Security and Stability in operational and planning time scales.

The focus of this report is on system wide aspects and system wide studies. For analysing the local impact of variable renewable generation, e.g. for identifying required grid reinforcements for interconnecting individual wind or PV-farms, other approaches may have to be applied, not covered by this report.

TECHNOLOGY

6 References

- [1] IEEE/CIGRÉ Joint Task Force on Stability Terms and Definitions, „Definition and Classification of Power System Stability,“ IEEE Transactions on Power Systems, Vol. 19, No. 2, May 2004.
- [2] North American Reliability Corporation (NERC), „Methods to Model and Calculate Capacity Contributions of Variable Generation for Resource Adequacy Planning,“ March 2011.
- [3] E. I. a. M. Milligan, „A Probabilistic Approach to Quantifying the Contribution of Variable Generation and Transmission to System Reliability,“ in 11th International Workshop on Large-Scale Integration of Wind Power into Power Systems as well as on Transmission Networks for Offshore Wind Power Plants, Lisbon, 2012.
- [4] H. Holttinen et. al., „Recommendations for Wind Integration Studies,“ in 11th Workshop on Large-Scale Integration of Wind Power into Power Systems as well as on Transmission Networks for Offshore Wind Power Plants, Lisbon, 2012.
- [5] M. Pöller, „Develop a Proposal of the Methodology for the Determination of the Capacity Credit for Electricity Generated by Renewable and Cogeneration Plants,“ GIZ, Mexico, 2010.
- [6] M. Pöller, „Capacity Credit of Wind Generation in South Africa,“ GIZ, Energy Department of the Republic of South Africa, ESKOM, South Africa, 2011.
- [7] Deutsche Energieagentur, „Energiewirtschaftliche Planung für die Netzintegration von Windenergie in Deutschland an Land und Offshore bis zum Jahr 2020 (dena 1 - Studie),“ Deutsche Energieagentur, Deutschland, 2003.
- [8] VTT-Research Institute, „The impacts of hourly variations of large scale wind power production in the Nordic countries on the system regulation needs“.
- [9] IEEE, „IEEE 421.5 - 2005: IEEE Recommended Practice for Excitation System Models for Power System Stability Studies,“ IEEE, 2005.

As a federally owned enterprise, we support the German Government in achieving its objectives in the field of international cooperation for sustainable development. Items from named contributors do not necessarily reflect the views of the publisher.

Published by

Deutsche Gesellschaft für
Internationale Zusammenarbeit (GIZ) GmbH

Registered offices

Bonn and Eschborn, Germany
Dag-Hammarskjöld-Weg 1-5
65760 Eschborn, Germany
Phone: +49 61 96 79-0
Fax: +49 61 96 79-11 15
Email: info@giz.de
Internet: www.giz.de

Sector project:

Technology Cooperation in the Energy Sector

Responsible

Klas Heising (Klas.Heising@giz.de)

Authors

Moeller & Poeller Engineering (M.P.E.) GmbH (Consultancy)

Design and Layout

Diamond media GmbH, Neunkirchen-Seelscheid

As at

Eschborn, original publication October 2014, 2nd Edition July 2015