

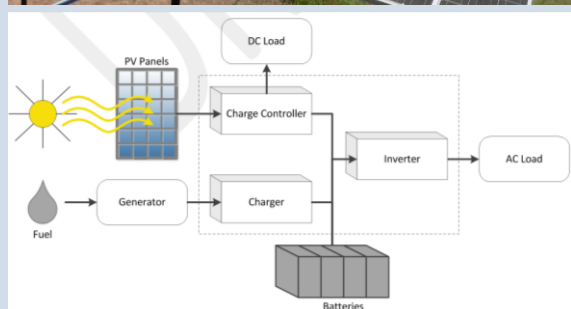

A user guide to simple monitoring and sustainable operation of PV-diesel hybrid systems

Handbook for system users and operators



PVPS

PHOTOVOLTAIC
POWER SYSTEMS
PROGRAMME

Report IEA-PVPS T9-16:2015

INTERNATIONAL ENERGY AGENCY
PHOTOVOLTAIC POWER SYSTEMS PROGRAMME

A user guide to simple monitoring and sustainable operation of PV-diesel hybrid systems

Handbook for system users and operators

This report contains a suggestion for a simple monitoring and evaluation guideline for PV-diesel hybrid systems. It offers system users a way to better understand if their system is operated in a way that will make it last for a long time. It also gives suggestions on how to act if there are signs of unfavourable use or failure. The application of the guide requires little technical equipment, but daily manual measurements. For the most part, it can be managed by pen and paper, by people with no earlier experience of power systems.

The guide is structured and expressed in a way that targets PV-diesel hybrid system users with no, or limited, earlier experience of power engineering. It is less detailed in terms of motivations for certain choices and limitations, but rich in details concerning calculations, evaluation procedures and maintenance routines. A more scientific description of the guide can be found in a related journal article.

IEA PVPS Task 9

Report IEA-PVPS T9-16: 2015

ISBN: 978-3-906042-40-4

3 November 2015

Author: Caroline Bastholm

Content

1	Introduction/Summary	3
2	PV-diesel hybrid systems	5
2.1	System components	5
2.2	Energy system balance	8
2.3	System operation	9
2.4	Maintenance	11
3	Measurement equipment – Chapter for electricians	14
3.1	Installation of measurement equipment	14
3.2	What to explain to the user	19
3.3	Identify suitable scale for the graphs	20
4	Measurements	23
4.1	When to take measurements	24
4.2	How to take measurements	25
4.3	Calculations	27
4.4	How to plot the obtained values in a graph	29
5	Short term evaluation	33
5.1	Battery voltage	33
5.1.1	Evaluation procedure	33
5.1.2	Battery voltage scenarios	34
5.1.3	Descriptions of scenarios	34
5.2	Load and generation	38
5.2.1	Evaluation procedure	38
5.2.2	Load and generation scenarios	38
5.2.3	Description of scenarios	40
6	Long term evaluation	46
6.1	Calculations	46
6.2	Plot the calculated values in graphs	54
6.3	Evaluation	55
6.3.1	Battery voltage	55
6.3.2	Load	57
6.3.3	Generation	57
6.3.4	Share of PV	59
6.3.5	Normalized PV Yield	60
6.3.6	System Losses	60
6.3.7	Fuel Consumption	61
6.3.8	Yearly evaluation	62
7	In case of a blackout	64
8	Afterword	65
	Template 1: Table for measured data and calculations for short term evaluation	67
	Template 2: Short term evaluation graphs for 12 V systems	69
	Template 3: Short term evaluation graphs for 24 V systems	70
	Template 4: Short term evaluation graphs for 48 V systems	71
	Template 5: Table for long term evaluation	72
	Template 6: Long term evaluation graphs	74
	Give feedback on the guideline	75

1 Introduction/Summary

This is a suggestion on how to monitor and evaluate PV-diesel hybrid systems. It offers system users a way of understanding if their system is operated in a way that will make it last for a long time. It also gives suggestions to how to act if there are signs of unfavourable use or failures. The application of the guide requires little technical equipment, but daily manual measurements. For the most part, it can be managed by pen and paper, by people with no earlier experience with power systems.

The guideline has been developed based on field experiences and literature reviews. It has, at the time of being published, not been tested in full on any real case. We are grateful to all users who are interested in applying the guideline, and we highly appreciate all feedback on the guideline.

For whom is the guideline suitable?

The guide is suitable for schools, hospitals, organizations, villages and private users having their own power supply system based on solar energy (PV) and generator(s) for power production. The guideline is developed to be useful for people that have no, or very little, earlier experience of the operation of power systems.

What types of systems?

The guide can be used for systems with the following specifications:

- The electricity is generated using solar energy (PV) in combination with one or more fuelled generators (diesel, gasoline or other liquid fuels).
- Energy is stored in solar batteries of lead acid type.
- The system is equipped with manually operated generators. (The guide could to some extent also be used in systems with automatically operated generators. It can help to evaluate the settings of the automatic generator start. It could also be used in systems with continuous operation of generators. In such cases, the guide can help the user to understand if the system has the capacity to handle the applied load. This is however not further discussed specifically in the guideline.)
- Battery bank voltage of 12 V, 24 V or 48 V. (For other voltages, there are no templates. Somebody knowledgeable in energy and electricity can modify the templates to be suitable also for other battery voltages.)
- Charge controller of series type. (If a shunt regulator is used, the guideline can be used if the system has no DC-load connected)
- The system can have a DC distribution network, an AC distribution network, or both.
- The system is located in a tropical or sub-tropical environment at low latitude.

What will it give you?

The guideline offers system users a better way of understanding if a system is operated in a way that will make it last for a long time. Common to PV and PV-hybrid systems is that the storage (batteries) fail too early. By operating the system in a favourable way, the lifetime of the batteries can be prolonged for several years. This, in turn, has effects on the economy, since batteries constitute a considerable part of the total lifetime system cost. It can also lead to more short term and long term economical operation of the generator.

The guideline facilitates understanding of relations between different parameters in a system; where and how energy is generated and consumed. This enables a user to know whether a system is working at its full capacity, over its capacity, or if the system has capacity to handle even more loads.

Through suggested maintenance routines and evaluation of obtained data, the user of this guideline can more easily detect failures in the system. Many failures would require an electrician to come and make further analyses. If the errors are detected early, though, the risk of subsequent errors harming other system components is lowered.

What measurements are required?

- **Battery voltage measurement.** Measured using a voltmeter or a multi meter. If charge controller or inverter displays the battery voltage or the battery state of charge, this value can possibly be used.
- **Energy from PV.** Measured using an accumulative DC energy meter. If the charge controller displays incoming energy from PV, this value can possibly be used.
- **Energy from generator.** Measured using an accumulative AC energy meter. If the AC charger displays incoming energy from the generator, this value can possibly be used.
- **Energy to AC load.** Measured using an accumulative AC energy meter. If the inverter is displaying energy going to AC load, this value can possibly be used.
- **Energy to DC load.** Measured using an accumulative DC energy meter. If the charge controller displays energy going to DC load, this value can possibly be used.
- Optional: **Fuel consumption.** Measured using an automatic fuel log. (Manual logging of all fuel fills can also be used)

What are the measurement and evaluation routines?

Measurements are taken manually once a day, at the same time every day. It shall be done when generation is as low as possible and load is as low as possible. This can be in the very early morning, before the sun rises and before daily activities that use electricity start. Measurements are noted in a table, and some values are calculated. Some values are then plotted in graphs. Templates for graphs are provided in the guideline. The graphs are used every day to evaluate the system performance. That is the short term evaluation. Long term evaluation is carried out once every month. It requires some further calculations. Also, the guideline suggests some maintenance routines that are recommended to be carried out every month. After each year, a yearly evaluation is suggested.

Structure of the guideline

The guideline starts with a general description of PV-diesel hybrid systems and their key components. The same chapter also includes general advice to how to operate a PV-diesel hybrid system and suggested maintenance routines. Thereafter follows a chapter aimed at electricians. It includes explanations on how to install the measurement equipment and what the electrician should explain to the user of the guideline. The following chapter explains how to take measurements, and how to enter values in tables and graphs. The chapter thereafter contains the short term evaluation routines and suggestions for actions when needed. Then follows the long term evaluation chapter, containing further calculations as well as evaluations to be carried out monthly and yearly. Towards the end is a chapter including suggestions on what to do in the case of a black out. There are also some afterword explaining the forum in which the guideline has been developed. The appendix gives templates for tables and graphs.

2 PV-diesel hybrid systems

In a PV-diesel hybrid system, solar panels (PV) and generator(s) are connected and collaborate to supply all connected power consuming appliances with energy. Those appliances are called load. The systems mostly have batteries too. These store energy, and make it possible to use the energy at times when the generator is off and the sun is not shining. The system also has other components that control the system, such as PV charge controller, inverter and AC charger. The energy is transported in electrical wires between different components of the system. Wires or cables are also used to transport the energy to the load. This is called the distribution system. The system also has fuses. These make the system safe, by automatically disconnecting faulty parts of the system. Breakers make it possible to manually cut the power to selected parts of the system.

Regular maintenance is required in order to keep a system in good condition. It also enables identification of possible errors and failures. Regular maintenance should be carried out by the system user. Many problems that may occur in a system are difficult to identify though. Therefore an annual overall check by an electrician is recommended.

This chapter has four different sections. The first one describes the components of a PV-diesel hybrid system. Thereafter is a section explaining the energy balance of the whole system. The third part gives some general suggestions for PV-diesel hybrid system operation. The last part concerns suggested maintenance.

2.1 System components

The following section describes the most important components in a PV-diesel hybrid system. It explains what the components do, and what they need in order to function properly. *Figure 1* shows a schematic drawing of a PV-diesel system.

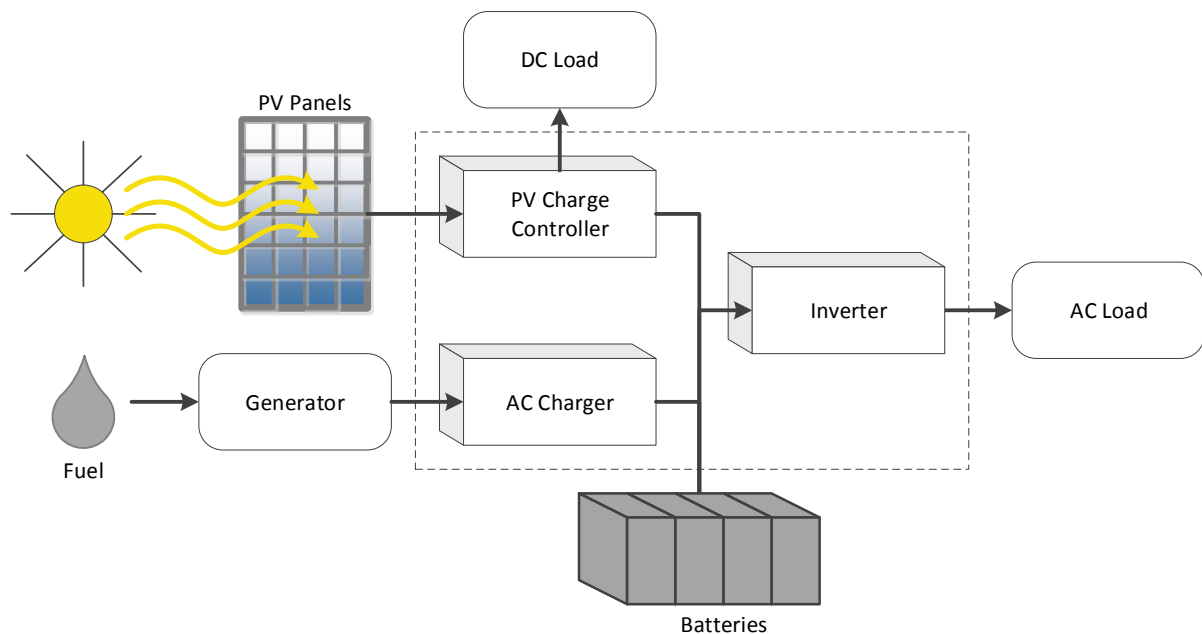

Figure 1: Schematic drawing of a PV-diesel hybrid system

PV panels

The PV panels, also called solar panels, generate electricity from the sun. The more sunshine that falls on the panels, the more electricity is generated. It is therefore important that the panels are not shaded or dirty. Even a little shade reduces the performance considerably.

Generator

The generator generates electricity by using liquid fuel. In this guide, we talk mostly about diesel generators. Also generators using other fuels, such as gasoline or propane, can be used. The guideline can be applied to such systems as well.

A generator performs best if it is loaded in relation to its size. That is with loads of around 80 % of its rated capacity. If it is used for only little loads, the fuel consumption is high compared to the electricity that is generated. It is recommended not to run the generator at lower load than 40 % of its rated capacity. A generator degrades faster if it has many starts and stops. It also consumes more fuel during the first minutes after the start. In the generator specifications, you can probably find the minimum suggested running-time for your generator once it is started. There are also other suggestions specific to your generator.

Battery

The battery is the energy storage. Electricity that is generated by the PV panels or the generator, which is not consumed directly by the loads, will be stored in the batteries. The energy can then be used later when needed. The batteries should be kept in a cool, dry and clean place. Some battery types must regularly be filled with distilled water. Read the instructions from the battery manufacturer to find the maintenance routines suggested for your batteries. Lead acid batteries are common in PV systems. They will function for much longer if they have a lot of energy stored in them most of the time.

Load

The load is all electrical appliances connected to the system. It can be lamps, refrigerators, computers, mobile phone chargers, TVs, kitchen appliances, laboratory equipment, and much more. The electricity is delivered to the loads through a distribution system of wires or cables. This can be either AC or DC. DC equipment cannot use AC power, and vice versa. AC is used in the large, national power grids. Most electrical appliances that are bought in common stores, such as refrigerators, radios, TVs, computers and so on, use AC. DC is more commonly used in small solar systems. Special solar lamps are powered by DC power. There are also other appliances on the market, special TVs, radios, refrigerators and phone and laptop chargers that use DC power. Such DC appliances must be customized to the voltage used in the system.

PV Charge Controller*

The charge controller is a very important component for the long term sustainability of the system. Without the charge controller, the batteries can fail very soon. When the batteries are full, the charge controller prevents over charging of the batteries. If the batteries do not have enough energy, the charge controller can cut off the loads. That protects the batteries from over discharge. There are two different types of PV charge controllers; the shunt controller and the series charge controllers. This guideline is tailored for series controllers. The user manual of the charge controller, an electrician or the solar equipment vendor can help to identify the type of charge controller.

Inverter*

An inverter can transform DC power into AC power. The electricity from solar panels and in batteries is DC, but many loads are AC. Therefore it is sometimes necessary to transform from DC to AC.

AC Charger*

An AC charger can transform AC power into DC power. This is needed if you wish to use a generator to charge the batteries. A generator produces AC power, and the batteries store DC power.

* The PV charge controller, the inverter and the AC charger can be three different devices, or combined in one or two components. Often, the inverter and the AC charger are combined to form a bi-directional inverter.

Fuses

A fuse is a safety device that can shut off the electricity automatically. This will happen if there is a short circuit in the system, or if too much load is connected to the system. It is important to choose fuses of the right size, in order for them to do a proper job. If a fuse is blown, it must be replaced by a new proper fuse. Fuses should never be by-passed. There are different types of fuses. Some types can be reset. Other types need to be replaced every time they are blown. Here follows a list of some common fuse types:

- A circuit breaker has a lever that can be used to manually close and open a connection. If such a fuse it is blown, the lever can simply be pushed back into the position allowing for electricity to pass.
- Some fuses are tubular, made of transparent plastic or glass. These fuses are placed in fuse sockets. The fuse contains a thin metal conductor. The conductor is in one piece as long as the fuse works well. When the fuse blows, the conductor will be burnt off and thereby separated into two pieces. The fuse must be replaced by a new one when it has blown.
- There are also tubular fuses with a ceramic surface which means that the connector cannot be seen. If you have a multi-meter, you can use the 'test diode function' to see if there is still connection between the different sides of the fuse. If not, the fuse must be replaced.
- Ceramic fuses have a little colour coded spring. The fuse is put into a fuse holder with a transparent window to make the colour coded spring visible. The holder with the fuse is screwed into a fuse socket. When the fuse has blown, the spring falls out. The fuse must be replaced by a new fuse when it has blown.



Figure 2: Circuit breaker



Figure 3: Tubular glass fuse



Figure 4: Tubular ceramic fuse



Figure 5: Ceramic fuse

Breakers and Switches

A breaker is a device that can be used to cut the power manually. A central breaker can be used to cut the power to all loads. It is also usual to have breakers for different parts of a distribution system, making it possible to shut down selected sections. There may also be breakers to connect and disconnect the PV panels and the generator(s). Smaller breakers for lamps in a certain room, or on certain electrical appliances, are usually called switches.

2.2 Energy system balance

In any energy system, it is important that the generated energy and the used energy are balanced. More energy than has been generated cannot be used. In well-functioning, large national grids, changes in use are balanced with changes in generation. In smaller systems, the energy balances must be considered more carefully by the user or system owner. The generation capacity is mostly limited. The users therefore need to understand what appliances can be connected to the system, and how much those appliances can be used. This guideline assists in creating such awareness.

To understand small electrical power systems, one can think of them as water-storage-systems (*Figure 6*). The electricity generated from PV can be compared to rain water collected on a roof. Not all the sunshine or water can be harvested, but some. In a water storage system, the water is led through pipes to a compartment, a water tank, where it can be stored. In a power system, the storage compartment is the battery. Electricity is transported to the batteries in electrical wires. In the water system, the pipes may leak a bit. Therefore, not all the water that was collected on the roof comes into the water tank. The same goes for the electrical wires. They also have some small losses.

When the electricity is stored in the batteries, there are always some losses. That can be thought of as a poorly sealed water tank that always has some water dripping out of it. Water tanks can be sealed. But, unfortunately there is no way of completely avoiding loss of energy from batteries (with today's technologies). When a water tank is full, the water will run over its sides, and no more water can be stored. Batteries, though, cannot handle too much electricity coming in. Therefore, the charge controller is used. The charge controller checks the level of energy in the batteries, and stops the flow of electricity to the batteries when they are full.

Water in a water tank can be used until the water tank is empty. If a battery gets completely empty, it is damaged. The charge controller (or the inverter) is again a crucial device. The charge controller checks the level of energy in the battery. If the battery is reaching a low level of energy, the charge controller will cut off the energy supply to the load.

To enable people to use the water in a water tank, it can be transported in pipes to a tap. People can open the tap and fill their buckets with water when they need it. In an electrical system, the electricity is transported from the batteries in wires or cables. When the electricity is to be used, a person can turn on a switch, and the electricity is used in the form of, for example, light. The water pipes as well as the wires can have some small losses. If a tap is faulty, it may drip. If an electrical appliance is faulty, it may consume electricity although it is turned off. A faulty electrical appliance

that consumes too much electricity when it is in use can be compared to a broken bucket. When filled with water, some of it runs out through the holes in the bucket.

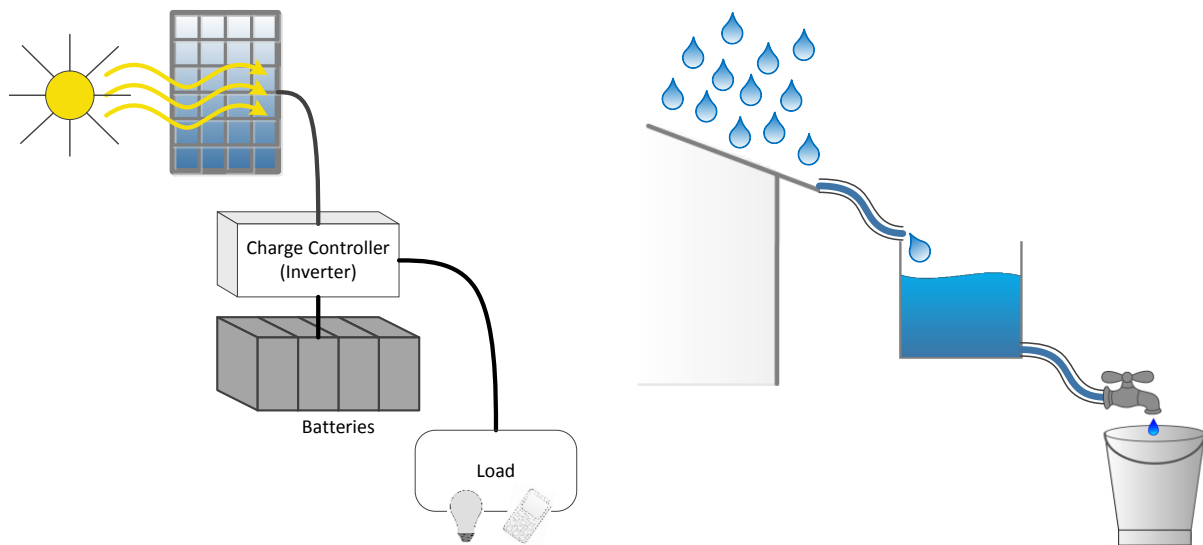

Figure 6: A Power system and a water storage system.

As described above, there are several possible losses from an electrical system, for example from wires and from the battery. This means more electricity needs to be generated in order to meet all needs. The generated energy must cover all the loads, plus the energy that is lost. That is similar to more water having to be collected than is required, in order to cover the water losses.

The magnitude of the losses depends partly on how the system is built. There are more and less efficient charge controllers, inverters and AC chargers. A more efficient component leads to lower losses, and a less efficient one results in higher losses. If wires and cables in the system are long, the losses will increase. The losses will also be larger if the cables are thinner than they should be. Also different battery types have different amount of losses. The PV panels can be better or worse at converting sunshine to electricity, and a generator can be better or worse at converting the energy in the fuel to electricity. The efficiencies of the PV panels and a generator depend both on how they were originally constructed, and how well they are maintained. When we later in the evaluation calculate losses, these losses will not be included. It will still be possible to evaluate the efficiency of the PV panels and the generator(s) though, using other parameters.

How large losses a system has also depends on the operation of the system. If a lot of the energy is used at the same time as it is generated, there will be smaller losses from the batteries than if a lot of energy is stored and used later. Appliances can also have smaller or larger losses. These will not be included either when the losses are calculated in the evaluation, but it is equally important to consider them. Inefficient appliances will waste energy that could be used for something beneficial.

2.3 System operation

A system that is well operated will work more efficiently and last longer. Applying and following the recommendations in this guideline can facilitate the good operation of the system. Some general suggestions for PV-diesel hybrid system operation are also described here.

The batteries used in electrical power systems are sensitive. It is therefore necessary to operate the system in a way that is favourable for the batteries. If the system is run in a way unsuitable for the batteries, the batteries will fail early. Thereby the system will lose its capability of storing energy. Batteries are expensive. Frequent replacements of them will hence be a large economic burden. The battery type considered for this guideline is lead acid batteries. The lifetime of lead acid batteries depends, among other things, to a great extent on how deep they are discharged. This means that if your battery has only little energy in it, it will fail faster. Therefore, the batteries should never be deep discharged, and charged to their maximum level at least once a week. The lifetime of a battery also depends on how often it is discharged. A battery that is discharged more often will degrade faster. This guideline will enable monitoring of the battery, which can facilitate good operation. You can try to avoid frequent and deep discharge by using appliances that need a lot of energy at times when there is a lot of generation. The generation may come either from the PV panels, or from a generator. You can, for example, choose to use computers and lab equipment when the sun is shining. A generator works most efficiently at fairly high load, about 80% of its rated capacity. This gives the most useful energy per litre of fuel. It is therefore good to run the generator(s) at a time of day with a heavy load, for example in the evening if there are a lot of appliances in use then. Use of energy when the energy is generated is also good from the perspective of losses. If energy does not need to be stored in the batteries before it is used, the losses will decrease.

The amount of energy from the PV panels can also affect when it is smartest to run the generator. If there is already a lot of energy from PV, there may not be any need for energy from the generator. In many systems, it is most suitable to run the generator in the evening. A generator also consumes more fuel and degrades faster if it has many starts and stops. It is therefore better to plan the use of the generator so that it can be run for a longer continuous time, than to start and stop it frequently. The evaluation in this guideline will sometimes tell you to increase the generation by using the generator. That is when the batteries are discharged too much in the early morning. Instead of starting the generator right away in the middle of the day, though, it may be better to use the generator in the evening and see if the batteries are charged better the morning after. Otherwise there is a risk that the batteries are fully charged by energy from the generator, and that they cannot absorb the energy from the PV panels.

A PV-diesel hybrid system is designed to supply a certain load. That means that further appliances cannot always be attached to the power system, although they may be needed. The system is also sized to supply the loads for a certain amount of time every day. If the usage hours are extended, the system balance may be affected negatively. Most PV-diesel hybrid systems can handle more loads if the generators are used more though. This will, however, result in higher fuel costs. The evaluation in this guideline will help you to figure out if there is a possibility of expanding the use of your system.

It is always a good idea to consider what is already on the load side, before extending the use of the generator or even expanding the PV system. Many inefficient appliances, such as old light bulbs and old refrigerators, consume a lot of energy. Fortunately, there are also much more energy efficient products on the market. If, for example, light bulbs are replaced by energy efficient lights, and old energy consuming appliances are replaced by newer and more efficient items, a lot of energy can be saved. This energy can be used for longer operation of appliances, or to supply other, new appliances, that were not considered when the system was designed. Also if no more energy is

needed, it is a good idea to consider the possibility of making the load side more efficient. In this way the generator can be operated less, and fuel can thereby be saved.

2.4 Maintenance

Regular maintenance is crucial for the long term function of a power system. The maintenance routines described in this section can be used as a checklist. The checks should be done once a month, in order to prevent the system from easily avoidable failures. Each part or component of the system that should be checked is described separately in this section. In addition to the maintenance suggested here, it is also recommended that an electrician should do a system check-up once a year. This is to find degradations and failures that are more difficult to detect.

PV-panels

The easiest way to check your panels is to go outside and look at them. The most common errors that can be detected by visible inspections are listed below.

- Are your panels dirty? If so - clean them with water and a soft sponge or cloth. Dirt blocks the sunshine from reaching the panels, and the panels' efficiency therefore becomes reduced.
- Are your panels shaded by any vegetation or buildings? The sun angle changes over the seasons, and is different at different times of the day. Check the panels several times a day once a month on a sunny day. If there is shading during any time of the day, remove the object causing the shade (e.g. cut vegetation). You can also ask an electrician to move the PV panels to a spot where they are not shaded.
- Do any of the panels have any visible damage? If so, ask an electrician to check the effect such damage has on the system's performance, and give you suggestions as to what to do.
- Are all connections to each panel in place? You can touch the isolated wires carefully to check. If any are disconnected, they must be put back in place by an electrician or experienced person.
- When you have your measurement data, check that the E_{PV} value is not 0 on any day. This would mean that no energy was generated by the PV panels, which is unlikely. If you find a 0, check fuses and connections (see later in this section)

Diesel generator

- Check that all parts move smoothly when the generator is running. If not, ask a mechanic to check the generator.
- Make sure a good level of lubricating oil is maintained.
- Generators need regular oil and filter changes. Check the generator's manual for maintenance intervals on your generator.

Inverter, PV charge controller, AC charger (can be three, two or one separate unit(s))

- Are any of the devices covered by dirt or objects? If so – carefully wipe off the dust and remove the covering objects.
- Are cooling fins covered by dust and dirt? If so - carefully remove the dust and dirt.
- Does anything look faulty, such as burnt or melted? If so – contact an electrician who can examine the device properly.

- If the device has a display or a little light showing that it is operating, does it show figures? If not – does the device itself seem to function? Go to the section *Check charge controller, inverter and AC charger* in chapter 7 *In case of a blackout* for further support on how to check the device. If you find out that the inverter/charge controller/AC charger is operating, it is probably only the display or the little light on the device that is not functioning. The system can operate well anyway, but you can ask the electrician to look at it next time he or she comes. If the test of the inverter/charge controller/ AC charger shows that any of the devices are not working properly, you should call an electrician. Carry out the tests in chapter 7 *In case of a blackout* first so that you can explain to the electrician where you think the failure is.

Battery

- Are the batteries dirty? If so - clean the batteries by removing dirt and dust with a non-metallic brush.
- Is there corrosion on the battery terminals? If so, ask an electrician or an experienced person to clean them. An alkaline solution such as baking soda can be used. Use rubber gloves and safety glasses.
- Are the batteries covered by any object? If so – remove that object.
- Are the batteries located in a well ventilated room? If not – try to improve the ventilation. Batteries last longer if they are stored in a cool place. Ventilation helps to keep the temperature down. It also transports flammable gasses that may be emitted away from the batteries.
- Does the battery have any melted, burnt or smoke-coloured parts? If so – turn off your system by turning off inverter, charge controller and AC charger, alternatively use switches to disconnect the batteries from the system. Thereafter, call an electrician.
- Depending of the battery type there might be other maintenance routines needed. Open lead-acid-batteries need to be refilled with distilled water. Check the manual from the battery supplier for further details.
- Ensure that the batteries are fully charged on a regular basis.
- Measure the voltage over each battery separately and compare the values. The battery voltage should be similar for all batteries. If one or a few batteries have different voltage than the other, something may be wrong or on the way to break. Ask an electrician to check your batteries more carefully.

Connections

- Check if the connections in the system are loose by touching the insulated wires. Be very careful not to touch any naked wires. That is dangerous and can lead to serious injuries and death. Loose connections should be put back in place by a skilled person or an electrician.

Fuses

- If a fuse is blown, you have probably noticed it. If you need an explanation about different types of fuses, see chapter 2.1 *System components*. If a fuse on the line to load has blown, you have experienced a total or partial blackout. If a fuse from any of the power generating sources (PV and generator) is blown, you probably notice in the evaluation that the generated energy has decreased, and you have hopefully found the error already.

- Still, make it a routine to check the fuses as you carry out the other parts of the maintenance. If you find a blown fuse, go to the section *Check all fuses* in chapter 7 *In case of a blackout*. This explains how to look for errors and how to change the fuse.

Breakers and Switches

- Check the breakers and switches in the system to see if they are operating properly. Are lights and other appliances turned off when you turn off the breaker, and turned on again when you turn it on? Test the major breakers, and preferably also switches.
- If a breaker or switch does not turn the power off when turned to its off-position, contact an electrician to check if the breaker has, in some way, been bypassed or is broken.
- If a breaker or switch does not turn the power on when turned to its on-position, try to connect an appliance that you know is functional to the place controlled by that switch, for example a functioning light bulb. If that works, it is the appliances that are malfunctioning. If it does not work, it may be the switch that is broken. There may also be a loose connection somewhere. Call an electrician to help you replace the switch or to reconnect cables.

3 Measurement equipment – Chapter for electricians

In order to use this guideline for evaluation and operation of a PV-diesel hybrid system, some measurements are required. These are listed below. The measurement equipment must be installed by a skilled electrician. Electricity can injure and even kill people if it is not handled with care. Non-electricians can use the guideline, read the measurements and carry out the evaluation without any risk. How that is done is described in following sections. This chapter explains what measurements shall be taken, and what they will be used for. Therefore, it is also useful for the user to read the chapter. But, do not try to install the measurement equipment yourself if you are not an electrician.

Required measurements

- Battery voltage (V_{Batt}) (or battery state of charge)
- Energy from PV (E_{PV})
- Energy from generator (E_{Gen})
- Energy to AC load (E_{AC})
- Energy to DC load (E_{DC})
- Optional: Fuel consumption (Fuel)

Since every system is a little different, it is important that the electrician understands what is to be measured. This is in order to choose the right measurement devices and the right measurement points. This is explained in this chapter. A section explaining what the electrician has to inform the user about is also included. The electrician is also asked to help the user to identify a suitable scale for the graphs templates showing energy measurements. This is explained at the end of this chapter.

3.1 Installation of measurement equipment

Again, this work should be carried out by a skilled electrician. If not handled with care, electricity can be very harmful and lead to severe injuries and death.

For each one of the proposed measurements, a short introduction is given on what the measurement is used for. Then follows suggestions for which measurement equipment shall be used, and where in the system it should be placed. *Figure 7* shows a schematic drawing of where measurements should be taken. *Figure 8* further clarifies the discussed possible measurement positions by letters, which are referred to in the text.

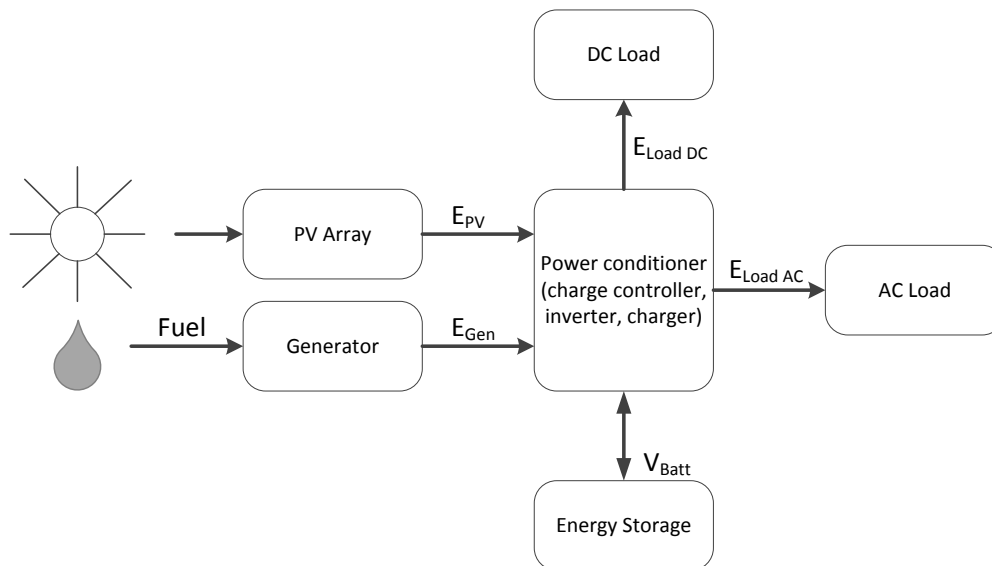

Figure 7: Schematic drawing of where measurements are taken.

Battery voltage (V_{Batt})

The battery voltage is crucial for the evaluation process. It is used to evaluate the status of the batteries. Therefore, it is important that the measurement is carried out with accuracy. The battery voltage is measured in volt [V].

The battery voltage (in volt) is used as an estimate of the battery state of charge (in %). If the battery state of charge can be obtained for example from the charge controller, that value can with advantage be used instead of the battery voltage. That requires the electrician or somebody else knowledgeable to adjust the scale of the battery voltage graphs.

Measurement equipment: To measure the battery voltage, an ordinary voltmeter or multi meter is recommended. Some charge controllers and inverters have inbuilt battery voltage measurements shown on a display. If such inbuilt functions are to be used, the accuracy of the measurement should be ensured by comparison with a trusted measurement device, such as a good voltmeter. The measurement equipment should have a resolution of at least one digit after the decimal point (e.g. 12.8).

If the battery state of charge (in %) is displayed on the charge controller or inverter, that measurement can be used instead of the battery voltage.

Measurement point: The total battery voltage over the whole battery bank shall be measured. Most often, the easiest place to take the measurement is at the charge controller's battery connectors. If values displayed on the charge controller or on the inverter are used, instead of using a multi meter/volt meter, the display shows the current total battery voltage. If the battery stage of charge is displayed on the charge controller or inverter, that value can be used if the scales on the battery graphs are adjusted.

Energy from PV (E_{PV})

The energy from PV is used in the evaluation in order to understand how much electricity the solar panels are generating. Together with the energy from the generator and the load, it is used to understand and evaluate the system energy flows and the utilization of the system capacity. On a

long term basis, the daily generated energy from PV will also give indications of system changes that may indicate failure. The energy from PV is measured in [kWh/day].

Measurement equipment: The energy from PV is measured using an accumulative DC energy meter. Some charge controllers have inbuilt accumulative metering of incoming energy from PV. This value can be used.

Measurement point: The energy from PV is preferably measured between the PV array and the charge controller (point A in Figure 8). That allows for systems configurations with DC loads connected to the charge controller. It is also suitable for systems with charge controller, inverter and AC charger combined in one unit.

The guideline is best suited to systems with series controllers. If a charge controller of shunt type is used, the measurement must be taken after the charge controller (point B in Figure 8)*. Otherwise the obtained values will not be relevant in the proposed evaluation. Taking the measurement after the charge controller would, however, imply that the measured value includes the losses in the charge controller. If the system has a shunt controller and DC load connected directly to it, the guideline will not give reliable results.

If the system has multiple PV arrays with separate charge controllers, the measurement shall be taken before each charge controller (or at or after according to the same description as for systems with only one PV array). That is also valid if the system has a PV array connected directly to the AC distribution system, via a separate inverter. In that case, the measurement is taken before the inverter. If several energy meters are used, their values must be added to get the total energy from PV, E_{PV} .

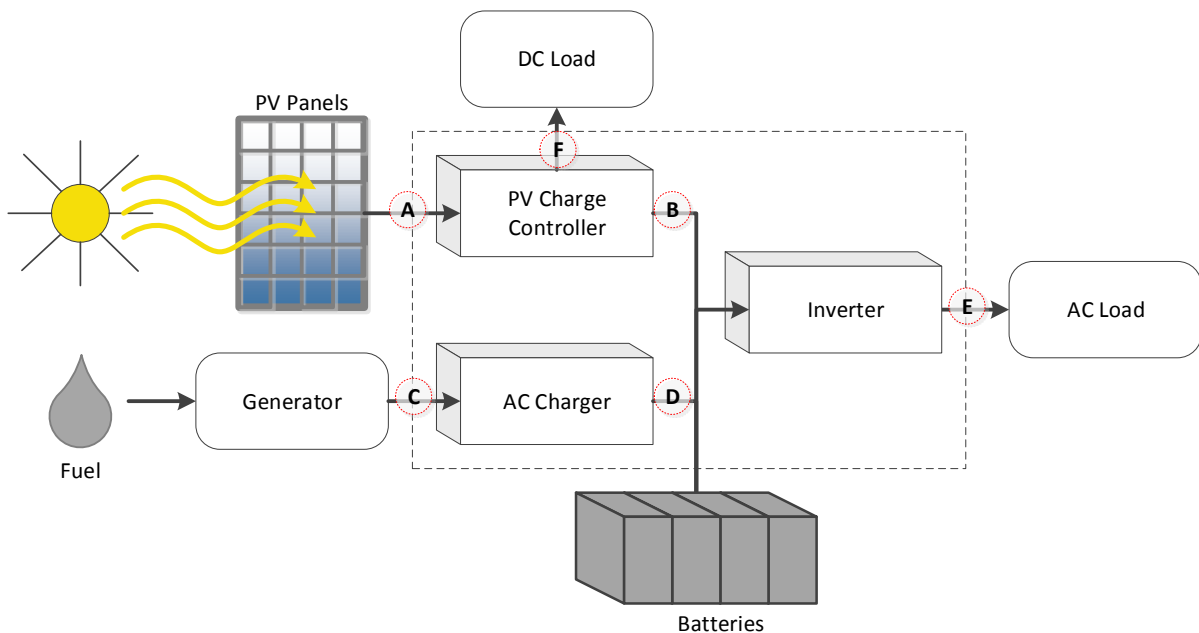

Figure 8: System drawing with letters clarifying the possible positions of measurements described in this section.

Energy from generator (E_{Gen})

The energy from generator is used in the evaluation in order to understand how much electricity comes from the generator. Together with the energy from PV and the load, it is used to understand

and evaluate the system energy flows and the utilization of the system capacity. On a long term basis, the daily generated energy from generator will also give indications on system changes that may indicate failure. The energy from generator is measured in [kWh/day].

Measurement equipment: The energy from the generator is measured using an accumulative AC energy meter. Some bi-directional inverters and AC chargers have inbuilt accumulative metering of incoming energy from the generator. This value can be used.

Measurement point: The energy from diesel generator(s) shall preferably be measured between the generator and the charger (point C in Figure 8). If a bi-directional inverter is used, this is a must. If an AC charger is used, the measurement could be taken between the AC charger and the further system infrastructure (point D in Figure 8)*. Values measured after the AC charger would also contain losses in the charger though.

If the system has more than one generator, the measurement shall be taken after each generator. If several energy meters are used, their values must be added to get the total energy from generator, E_{Gen} .

In some systems, a generator is connected to a PV-diesel hybrid system via an AC charger, but also to loads directly. Those directly connected loads can therefore only be operated when the generator is running. If the generator is connected directly to some loads, that load does not need to be included in the measurements. The energy from the generator is still measured just before the charger.

*If the measurement of energy from PV is taken on the output side of the charge controller, the measurement of the energy from generator should preferably be taken on the output side of the AC charger, and vice versa. This is however only possible if the AC charger is a separate unit (not combined with the inverter to a bi-directional inverter) and the system has no DC load. Placing the measurement devices in this way will imply that the energy from PV measurement will contain the losses in the charge controller, and the energy from generator measurement will contain the losses in the AC charger. It is better that both values contain the losses than only one. The best is, however, if the measurements are taken on the input side of the charge controller and the charger, respectively.

Energy to AC load (E_{AC})

Most systems that are not very small have AC distribution and thus AC loads. The energy to AC load is used in the evaluation together with the energy to DC load in order to understand how much electricity is used in the system. Together with the generated energy (from PV and generator), the energy to loads are used to analyse energy flows and the utilization of the system capacity. On a long term basis, the daily energy to AC load gives indications of changes in use of electrical appliances. It can also help to identify failures. The energy to AC load is measured in [kWh/day].

Measurement equipment: The energy to AC load is measured using an accumulative AC energy meter. Some inverters have inbuilt accumulative metering of energy going to load (AC). This value can be used.

Measurement point: The energy to AC load is preferably measured right after the inverter (point E in Figure 8). In this way, all electrical appliances (AC) as well as all distribution infrastructures such as wires and junction boxes will be regarded as load.

In some systems, AC loads are connected to a generator without being a part of the PV-diesel hybrid system. Those directly connected loads can therefore only be operated when the generator is running. Such loads shall not be included in the measurements.

If the system has PV connected directly to the AC distribution system via a separate inverter, the AC load measurement needs to include that load also. Depending how connections are made, more than one energy meter may be required. Each meter is, in this case, installed right after each inverter. If several energy meters are used, their values must be added to get the total energy to AC load, E_{LoadAC} .

Energy to DC load (E_{DC})

Some systems have DC distribution networks, and consequently DC loads. Some systems use exclusively DC, some exclusively AC and other systems have separate AC and DC distribution networks and use both type of appliances. The energy to DC load is used in the evaluation together with the energy to AC load in order to understand how much electricity is used in the system. Together with the generated energy (from PV and generator), the energy to loads is used to analyse energy flows and the utilization of the system capacity. On a long term basis, the daily energy to DC load gives indications of changes in use of electrical appliances. It can also help to identify failures. The energy to DC load is measured in [kWh/day].

Measurement equipment: The energy to DC load is measured using an accumulative DC energy meter. Some charge controllers have inbuilt accumulative metering of energy going to load (DC). This value can be used.

Measurement point: The energy to DC load is preferably measured right after the charge controller (point *F* in *Figure 8*). That way, all electrical appliances (DC) as well as all distribution infrastructures such as wires and junction boxes will be regarded as load.

Depending how connections are made, the system may have separate DC distribution systems and more than one energy meter may be required. Each meter is in that case installed right after each charge controller. If several energy meters are used, their values must be added to get the total energy to DC load, E_{LoadDC} .

Optional: Fuel consumption (Fuel)

The fuel consumption is measured in order to evaluate the system and generator fuel consumption. The fuel consumption is only evaluated in the long term evaluation. Evaluation of fuel consumption is not the main objective of the guide but can be valuable additional information. Since the fuel consumption measurement does not affect the main evaluation, it can be neglected if desired. Unlike all other measurements, it is important that all fuel fills are logged. This is easy with automatic logging, but may be challenging if using manual logging. If all fuel fills are not logged, the evaluation related to fuel consumption will be very inaccurate. If there are reasons to believe that the fuel consumption will not be logged properly, one can ignore the fuel measurements and neglect the evaluation of fuel consumption from the evaluation.

Measurement equipment: It is strongly recommended that the fuel consumption is measured using an automatic fuel log. It can also be done by keeping manual records of all fuel fills, typically the litres of fuel put into the generator tank.

Measurement point: The automatic fuel log shall be placed as close to the actual fuel intake of the generator as possible.

Manual logging shall preferably examine the amount of fuel used in the generator. In larger systems, the generator may be connected to an external, large tank. In smaller systems, manual fill of the generators internal tank may be applied. Every time the fuel tanks are filled, regardless of whether it is a small or a large tank, the amount of fuel should be noted in a log book.

3.2 What to explain to the user

For the user of this guideline it is important to know how to read the different measurements, where to note down the values, and how to evaluate the measurement results. The electrician plays an important role here. Depending on the users' earlier experience with electrical power systems as well as graphs and calculations, the electrician's involvement may be crucial for the outcome. If the users are very inexperienced with electrical power systems, graphs, tables, calculations, or written instructions, it is suggested that the whole guideline is read by the electrician, and that it is gone through by the electrician and the users together.

Here follows a number of points that the electrician shall make sure that the user knows and understands:

- **Marking reading spots:** After finishing the installations, the electrician should show the user where (on which meter) to read what values. It may be easier for the user to remember if the devices are marked.
- **Noting down readings:** Each value shall be noted in a specific column in the table found in *Template 1: Table for measured data and calculations for short term evaluation*. The electrician shows the user where to note each value.
- **Adding values:** In cases when additions of values from different meters are necessary, for example if several PV arrays with separate charge controllers are used, that procedure should be explained to the user by the electrician.
- **Creating graphs:** Depending on the user's earlier experience with measurements and graphs, the electrician may need to help the user to understand how to mark the obtained values on the graph templates. Information on this is found in *4.4 How to plot the obtained values in a graph*.
- **Time for measurements:** It is important that the user understands why the measurements need to be taken at the same time every day, and at what time. The electrician can probably help the user to find a time that is suitable, both from a technical point of view and from a practical point of view. The requirements for when to take measurements are found in *4.1 When to take measurements*.
- **Scale for graphs:** The electrician shall help the user to identify and to put a suitable scale on the template for the graph showing generated energy and load (the lower one). Section *3.3 Identify suitable scale for the graphs* describes how to find a suitable scale.
- **System voltage:** Make sure that the user knows if the system voltage is 12, 24 or 48 V, and thus which template shall be used for graphs for the short term evaluation. If the system has a different voltage from any of the templates, the electrician can help the user to adapt the

scale to that voltage. If the battery state of charge is used instead of the battery voltage, the electrician shall help the user to put a suitable scale for state of charge on the battery voltage graph to replace the battery voltage.

- **Installed PV capacity:** In order to carry out the long term evaluation, the user will need to know the installed capacity of PV. Tell the user the value of installed PV capacity, in kW_p.
- **Design value for Share of PV:** For the long term evaluation, it will help the user to know what share of PV the system was designed for. Tell the user the design value of the percentage of the total generated energy that is meant to come from PV.
- **Logging fuel:** If manual fuel logging is applied, explain to the user how to measure and note the fuel consumption. Descriptions are found in the section about the log book in 4.2 *How to take measurements*.

3.3 Identify suitable scale for the graphs

In the templates for short term evaluation, graphs showing load and generation have no values on their axes. This is because different systems have very varying generation and loads. If the scale is poorly adapted to the values that are plotted in the graph, it will be difficult to see anything and to draw any conclusions from the graphs. Since the electrician has the most information about the system design, and possibly more experience with calculations and graphs, it is suggested that he or she helps the user to find a suitable scale for the graph.

Use the following recommendations to identify the scale on the load and generation graph:

- **Initial bottom value:** 0

Approximate initial top value: Firstly, multiply the total installed PV capacity by the maximum peak sun hours. Peak sun hours are the number of hours with solar insolation of 1000 W/m². If a location gets 5500 Wh of sunshine per square meter and day, the peak sun hours is hence 5.5. If you do not know the peak sun hours, use the value 6 for locations at low latitude with a lot of sunshine. Secondly, multiply the peak power of the generator(s) by the typical number of operation hours per day. (If more than one generator is used, take the peak power of each generator and multiply it by the typical daily operation hours of that generator.) Add the two values from PV system and generator. The value you get will be the approximate maximum kWh/day generated in the whole system:

$$\begin{aligned} \text{Approximate initial top value} &= \\ &= (\text{Total kW}_p \text{ of PV} * \text{peak sun hours}) + (\text{kW}_p \text{ of generator} * \text{daily hours of operation}) \end{aligned}$$

Example: A PV-diesel hybrid system has 1.4 kW_p of PV installed, and a generator with a peak power of 5 kW_p. The system is located near the equator with a lot of sun. The peak sun hours are around 6. The generator is used for around one hour every day.

$$\text{Approximate initial top value} = (1.4 * 6) + (5 * 1) = (8.4) + (5) = 13.4 \text{ kWh/day.}$$

- **Identify a scale** for the template, suitable to the obtained approximate initial top value. The scale should be easy to understand and use. It is therefore suitable to use a scale where the gap between each of the major grid lines in the template is as easy to handle as possible, for example 0.5, 1, 1.5, or 2 and so on. Consequently, the initial top value may not become the exact value that was calculated as the approximate initial top value. In the example, the chosen top value would probably have become 15 kWh/day.
- **Evaluate** after one month how well the scale works with the values that have been plotted. If there is a lot of space below or above the graph, the scale should possibly be adjusted in order to see changes in load and generation as clearly as possible.

If there is a lot of space below the graph (as in Figure 9), and there is always generation as well as load every day, there is no need to start the scale at 0. Instead, chose the minimum value you think may occur. Consider whether the month that has passed was a normal one, and if there are times with less load or generation. Set the bottom value to a value slightly lower than what you think will happen.

If there is plenty of space above the graph (as in Figure 10), the top value may be adjusted to a lower value. If it is unlikely that the generation or load is much higher during other months than the month you have evaluated, the top value can be lowered. Once again you can use the equation for the approximate initial top value, but change to the input data to fewer peak sun hours or shorter operation time for the generator(s). Set the top value slightly higher than the value you estimate will be the maximum generation in a day.

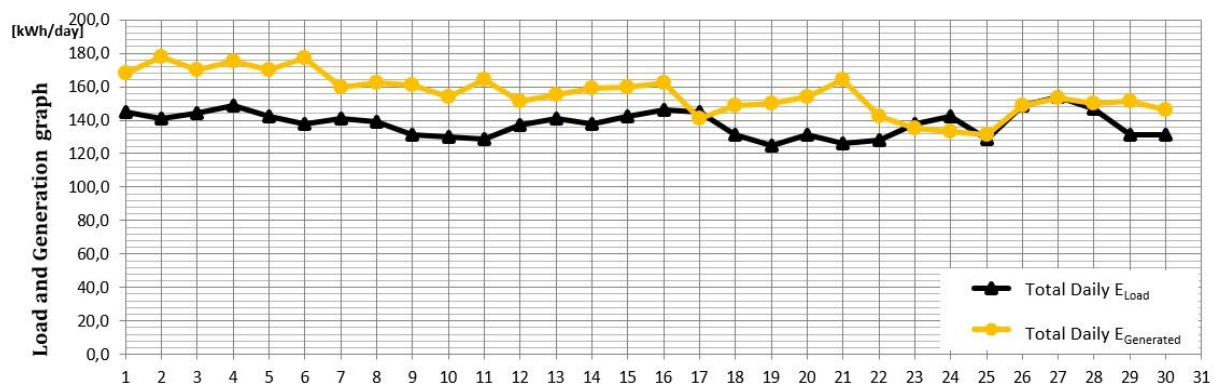

Figure 9: Example of a scale that can start at a higher number than 0. Here, the bottom value may be set to 100.

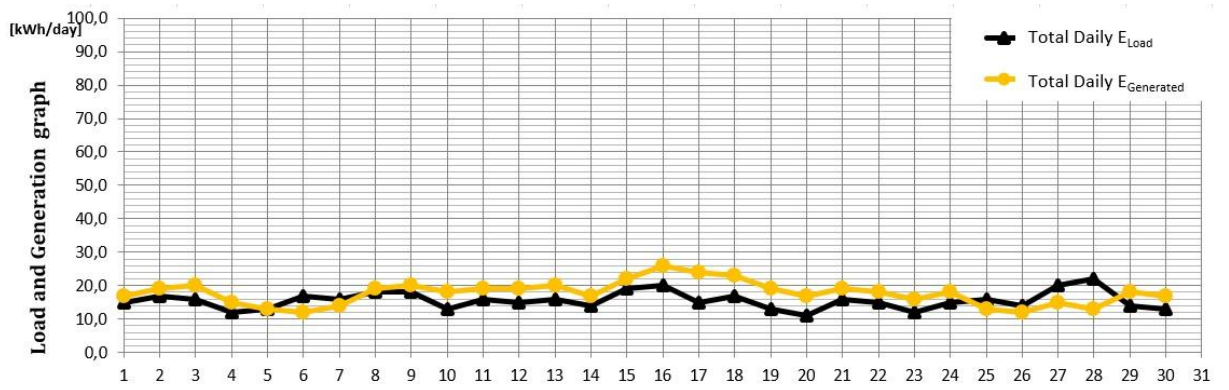

Figure 10: Example of a scale that goes too high. Here, the top value may be set to 40.

If the battery state of charge is used instead of the battery voltage:

- Set the top value to 110%
- Set the bottom value to the set point on the PV charge controller for automatic discharge of load. If this value is not known, set the bottom value to 40%.

4 Measurements

This guideline for improved operation of PV-diesel hybrid systems is based on measurements. Measurements need to be taken in order to compare and evaluate system data. It is very important that the measurements are taken and noted down accurately. This chapter explains when and how measurements are taken, and how they are noted in tables and graphs. In order to make sure that the measurements are carried out correctly, discuss the measurements with the electrician who made the installation of the measurement equipment.

The following measurements are taken:

Battery voltage (V_{Batt})

The battery voltage shows roughly how much energy is stored in the batteries. High voltage means a lot of energy, and low voltage means less. The battery voltage does not only depend on the amount of energy in the batteries though. The voltage is lower at the time of discharge and higher at the time of charge. The battery voltage measurements over time indicate if the system is operated well. The battery voltage is measured in volt [V].

The battery voltage is used as a simple way of estimating the state of charge of the batteries. If the battery state of charge is displayed on for example the charge controller, that value can with advantage be used instead. If the battery state of charge is used, discuss with an electrician how to use that value instead of the battery voltage.

Energy from PV (E_{PV})

The energy from PV shows the amount of energy that is generated by the solar panels. The energy from PV is measured in [kWh/day].

Energy from generator (E_{Gen})

The energy from the generator shows how much of the generated energy that comes from the generator. The energy from generator is measured in [kWh/day].

Energy to AC load (E_{AC})

The energy to AC shows how much energy is used in the AC distribution network, hence used by AC appliances such as TVs, computers and so on. The energy to AC load is measured in [kWh/day].

Energy to DC load (E_{DC})

The energy to DC shows how much energy is used in the DC distribution network. The measurement includes energy used by DC appliances such as light and possibly other customized products such as special laptop and mobile phone chargers.. The energy to DC load is measured in [kWh/day].

Optional: Fuel Consumption (Fuel)

The fuel consumption is measured in order to evaluate the system and generator fuel consumption. The measurement is not necessary in order to carry out the most of the evaluation suggested in the guideline. It is used to calculate the system fuel efficiency and the generator fuel efficiency. The measurement can hence be neglected if desired. Fuel consumption is typically measured in litres, but other volume units such as dm^3 , m^3 or gallons can also be used.

4.1 When to take measurements

All measurements must be taken at the same time every day, except the fuel consumption. It should be done when no power is generated by the PV panels, and no power is generated by the generator. Also, the load should be zero or as low as possible. These restrictions are due to the battery voltage. The battery voltage is only showing accurately the amount of energy in the batteries (the state of charge) when no power is taken from the battery or put into the batteries at the time of the measurement. We also want the battery voltage to be close to its daily minimum. In this way, the lowest battery charge level of the day is found.

For many systems, the best time to take measurements is in the very early morning, before sunrise, when it is still relatively dark. When it is dark, the PV panels are not generating any power. Also the generators in small PV-diesel hybrid systems are often turned off at night. The measurements should also be taken before people wake up and start to use electrical appliances. Many systems have very little load in the very early morning, compared to other times of the day. The batteries are in many systems at their lowest charge level in the very early morning, when all night loads have used energy from the batteries, and no power generation has yet started. If the measurements are to be taken in the early morning before sunrise, there may be a watchman who can read the measurements.

It is also important that the conditions from day to day are as similar as possible. This is another reason for recommending the early morning when it is still dark. Many places have very similar night loads every day, often comprising security light and maybe some refrigerator(s). Since there is no generation at all, that is also similar from day to day.

If this description does not match how your system is used, you should discuss with the electrician in order to find a time of the day that best fulfils the following requirements:

- No power generation from PV
- No (or low and very constant) power generation from generators
- As constant and preferably low load as possible

When a time for measurements is decided, it is important that the measurements are taken at that same time every day. Not more than 30 minutes deviation from the scheduled measurement time should be allowed. The measurements are noted in the table found in *Template 1: Table for measured data and calculations for short term* at the end of this guideline.

The evaluation of the fuel consumption is valuable but not necessary for the rest of the system evaluation. If automatic fuel logging is used, the measurement shall be checked on the first day of each month and noted in the logbook. If manual logging is used, every single fuel fill must be logged in a logbook. If desired, the fuel measurements can be ignored. This will however mean that the system and generator fuel consumption cannot be calculated and evaluated.

4.2 How to take measurements

This section explains how to take the measurements, and where to note them in a table. Since the electrician is the person who has installed the measurement equipment, he or she must explain where to read each value. This section lists some points that the electrician installing the measurement equipment can explain. You can also read about many of these points in chapter 3 *Measurement equipment – Chapter for electricians*.

At the end of this guideline, there is a template for logging measured and calculated data, *Template 1: Table for measured data and calculations for short term evaluation*. Part of the table is shown in *Figure 11*.

Year: _____ Month: _____

Template 1: Table for measured data and short term calculations

Day	Time [hh:mm]	V _{Batt} [V]	E _{PV} [kWh]	Daily E _{PV} [kWh/day]	E _{Gen} [kWh]	Daily E _{Gen} [kWh/day]	Total Daily E _{Generated} [kWh/day]	E _{LoadAC} [kWh]	Daily E _{LoadAC} [kWh/day]	E _{LoadDC} [kWh]	Daily E _{LoadDC} [kWh/day]	Total Daily E _{Load} [kWh/day]	Share of PV [%]	Logbook	Sign
1															
2															
3															
4															
5															
6															
7															
8															
9															

Figure 11: The template used to log measurements and calculations.

The table in the template is customized to fit one month's data on one sheet. White fields in the table show where to write measured values. The measurements are described in this section. The grey fields show where to note calculated numbers. The calculations are described in 4.3 *Calculations*.

The following data and measurements should be taken every day and noted in the table.

Time (hh:mm)

The exact time of the measurements should be noted every day, in the second column on the correctly dated row. The measurements should be taken at the same time, with a maximum of 30 minutes difference. Even if there is a mistake and the measurements are taken at a later or earlier time, it is important that the exact time for the measurements is written. Otherwise it may be difficult to know why measurement values show strange results.

Battery voltage (V_{Batt})

The battery voltage can be measured by using a volt meter, or read from the display of the charge controller (if displayed on it). If the value on the charge controller is used, the electrician must make sure that the displayed value is correct. He or she should also show you where to find the value on the display. If a voltmeter is used, the voltage over the whole battery bank should be measured. The electrician can show you how. The value is noted on the correctly dated row, in the third column called V_{Batt}.

Energy from PV (E_{PV})

The energy from PV can be measured using a DC energy meter. Some charge controllers have the energy from PV displayed. This value can be used instead, if the electrician has proven it to be correct. The electrician can show you how to find that number. Energy meters are mostly accumulative. That means that the energy meter displays the amount of energy that has been passing the meter since it was first used. In the column E_{PV} , the number read on the accumulative meter should be noted. Some systems have many groups of PV panels working together. Depending on how those are connected, several energy meters may be needed. If that is the case in your system, the electrician will tell you how to add up the numbers and what to write in the table.

Energy from generator (E_{Gen})

The energy from the generator can be measured using an AC energy meter. There are also AC chargers (and bi-directional inverters) that show the energy from the generator on a display. This value can be used, if the electrician has proven it to be correct. The electrician can show you how to find that number. The energy meters are mostly accumulative; the display shows the amount of energy that has passed the meter since it was first used. In the column E_{Gen} , the number on the accumulative meter should be noted. Some systems have many generators working together. Depending on how the system is built, several energy meters may be needed to measure all the energy coming from generators. If this is the case, the electrician will tell you how to add up the numbers and which number to write in the table.

Energy to AC load (E_{LoadAC})

The energy to AC load is measured using an accumulative AC energy meter. Some inverters have inbuilt accumulative metering of energy going to AC load. This value can be used if the electrician has proven it to be accurate. The value read on the meter shall be noted in the column E_{LoadAC} . In some systems, several energy meters are needed in order to measure the total AC load. If that is the case in your system, the electrician will tell you how to add the values on different meters.

Energy to DC load (E_{LoadDC})

The energy to DC load is measured using an accumulative DC energy meter. Some charge controllers have inbuilt accumulative metering of energy going to DC load. This value can be used if the electrician has proven it to be accurate. The value read on the meter shall be noted in the column E_{LoadDC} . If several energy meters are required, the electrician will tell you how to read and add values from different meters.

Logbook

In the column called logbook, things that can contribute to the understanding of the system behaviour should be noted. All information concerns the day before the logging. If you measure in the early morning of the 5th of June, you should think of what happened on the 4th. The logbook information can include the following information:

- Weather. Write shortly if it was sunny, cloudy, mixed, windy or for example all day rain.
- Occasions causing changes in loads. This could, for example, be a party, purchase of new electric appliances, school start or school finish, or extraordinary surgeries.
- Maintenance, cleaning of panels, water fills in open batteries.

- Problems in the system. Could be for example power cuts, blown fuses or components failing.
- If automatic fuel logging is used, the value of the fuel logger should be read and noted on the first day of each month.
- If manual fuel log is used, each litre of fuel put into the system shall be noted on the day of fuel fill. It is very important that no fuel fills are forgotten. A separate logbook can be used for fuel only, if that is perceived as more practical.

4.3 Calculations

In order to make use of the measured values, some calculations are needed. Calculations used for the short term evaluation are explained here. These are noted in the same table as the measured values. Some calculations are also needed for the long term evaluation. These are explained later in chapter 6 *Long term evaluation*.

The calculations can be carried out by the person taking the measurements, or by somebody else who will analyse the data. It is good to do the calculations and the evaluation as early as possible every day. This will give you the best prospect for adjusting the system operation if needed.

Calculations to be performed and noted in the template:

Daily E_{PV} [kWh/day]

Daily E_{PV} is the energy coming into the system from the PV panels during one day. The meters are, as explained earlier, usually accumulative. Therefore they count all the energy that has gone through them since they were installed. To get the Daily E_{PV} , take the measured value of E_{PV} today minus the E_{PV} value from yesterday:

$$\text{Daily } E_{PV} = E_{PV} \text{ Today} - E_{PV} \text{ Yesterday}$$

Example 1: This morning you read the value 854 on the energy meter showing E_{PV} .

$$\text{Daily } E_{PV} = 854 - 851 = 3 \text{ kWh}$$

Write 3 on today's Daily E_{PV} .

If there are no measurements from the day before, take today's E_{PV} minus the last number you measured as E_{PV} . Divide the number you get by the number of days that have passed since the last measurement.

$$\text{Daily } E_{PV} = \frac{E_{PV} \text{ Today} - \text{Last noted } E_{PV}}{\text{The number of days that have passed since the last measurement}}$$

Example 2: On June 8th, you read the value 6279 on the energy meter, and note it in the table. Yesterday and the day before, nobody noted any measurements. On June 5th, E_{PV} was 6261. Three days have passed since the last measurement (from June 5th to June 8th).

$$\text{Daily } E_{PV} = \frac{6279 - 6261}{3} = \frac{18}{3} = 6 \text{ kWh}$$

Write 6 on Daily E_{PV} for June 8th. The fields for June 7th and June 6th are left blank.

Daily E_{Gen} [kWh/day]

Daily E_{Gen} is the energy coming into the system from the generator(s) during one day. To get the Daily E_{Gen} , take the measured value of E_{Gen} today minus the E_{Gen} value from yesterday:

$$\text{Daily } E_{Gen} = E_{Gen} \text{ Today} - E_{Gen} \text{ Yesterday}$$

If there are no measurements from the day before: Take today's E_{Gen} minus the last number you measured as E_{Gen} . Divide the number you get by the number of days that have passed since the last measurement (further explanation with example under Daily E_{PV})

Total Daily $E_{Generated}$ [kWh/day]

The Total Daily $E_{Generated}$ is the total energy generated by PV and generators during the last day. It is hence all the energy entering the system since the last measurement. To get the Total Daily $E_{Generated}$, add the calculated values of Daily E_{PV} and Daily E_{Gen} :

$$\text{Total Daily } E_{Generated} = \text{Daily } E_{PV} + \text{Daily } E_{Gen}$$

Daily E_{LoadAC} [kWh/day]

Daily E_{LoadAC} is the energy used by AC appliances during one day. To get the Daily E_{LoadAC} , take the measured value of E_{LoadAC} today minus the E_{LoadAC} value from yesterday.

$$\text{Daily } E_{LoadAC} = E_{LoadAC} \text{ Today} - E_{LoadAC} \text{ Yesterday}$$

If there are no measurements from the day before: Take today's E_{LoadAC} minus the last number you measured as E_{LoadAC} . Divide the number you get by the number of days that have passed since the last measurement (further explanation with example under Daily E_{PV})

Daily E_{LoadDC} [kWh/day]

Daily E_{LoadDC} is the energy used by DC appliances during one day. To get the Daily E_{LoadDC} , take the measured value of E_{LoadDC} today minus the E_{LoadDC} value from yesterday.

$$\text{Daily } E_{LoadDC} = E_{LoadDC} \text{ Today} - E_{LoadDC} \text{ Yesterday}$$

If there are no measurements from the day before: Take today's E_{LoadDC} minus the last number you measured as E_{LoadDC} . Divide the number you get by the number of days that have passed since the last measurement (further explanation with example under Daily E_{PV})

Total Daily E_{Load} [kWh/day]

The Total Daily E_{Load} is the total load during the last day. It is hence all the energy that was used in the system since the last measurement. To get the Total Daily E_{Load} , add the calculated values Daily E_{LoadAC} and Daily E_{LoadDC} .

$$\text{Total Daily } E_{Load} = \text{Daily } E_{LoadAC} + \text{Daily } E_{LoadDC}$$

Share of PV = (Daily E_{PV} / Total Daily $E_{Generated}$) * 100

The Share of PV is the percentage of the generated power that comes from PV. If the result is 100 or close to 100, all or almost all the generated energy that day came from the PV. If the number is low, approaching 0, most of the energy was generated by the generator(s). To get the Share of PV, take

the calculated value in Daily E_{PV} and divide it with the Total Daily $E_{Generated}$. Multiply the value you get by 100, in order to get the value in the unit [%]:

$$\text{Share of PV} = \left(\frac{\text{Daily } E_{PV}}{\text{Total Daily } E_{Generated}} \right) * 100$$

4.4 How to plot the obtained values in a graph

In order to get a better overview of the obtained data, they are plotted in graphs. These graphs are used to evaluate the power system. *Figure 12* shows a partly filled out graph template. The graphs should be updated with the new measured values every day. At the end of the guideline, there are templates for graphs. There are three different templates: for systems having 12 V, 24 V and 48 V battery banks respectively. Use the template that corresponds to the voltage of your system. For systems with other battery voltages, the templates must be adjusted. The electrician should be able to help with that.

As can be seen in *Figure 12*, the templates have two different sections for different graphs. The top part of the template is used to plot battery voltage. The scale is thus different in the different templates for different battery voltages. All y-axes (vertical axes) show values in the unit volt [V]. The upper as well as the lower graphs of the templates have dates on the x-axis (the horizontal axis).

In the lower part of the template, the total generated energy and the total load shall be plotted. That graph has no axis values in the template. The reason is that systems are very different in size. If the scale is not adapted to the system size, it may be very difficult to draw any conclusions from the graph. The electrician can help to define a proper scale. How to define a proper scale is also explained in the section 3.3 *Identify suitable scale for the graphs*. The y-axis (vertical axes) shall show values in the unit of [kWh/day].

At the very bottom of the template, there is space to fill in the calculated value share of PV as well as the weather.

Figure 12 shows an example of graphs drawn in a template. When the graphs are drawn, use different colours for the different graphs if possible. Further explanations to how to fill in the graphs template are found after *Figure 12*.

Day	Time [hh:mm]	V_{BATT} [V]	E_{PV} [kWh]	Da E [kV da
1	04:52	12.60	123.36	4.02
2	04:58	12.48	127.54	4.18
3	05:05	12.42	131.34	3.80
4	04:56	12.52	133.89	2.59
5	05:10	12.55	136.91	3.02
6				
7				
8				
n				

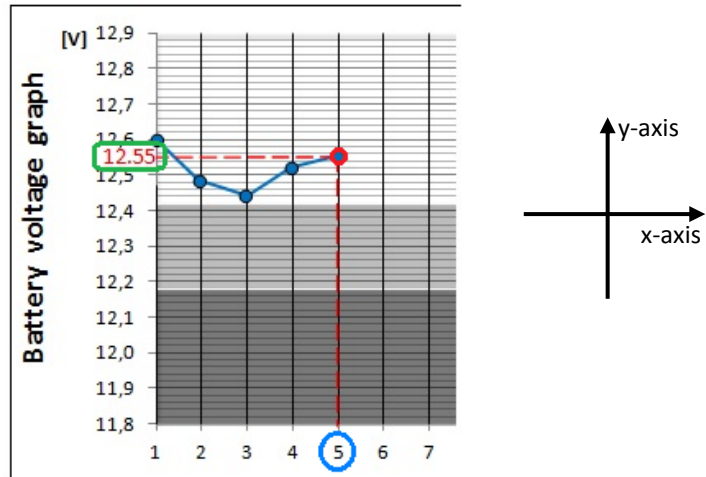

Figure 13: Example of a filled in table and Battery voltage graph, and the identification of x-axis and y-axis. .

Total generated energy: Total Daily $E_{Generated}$

1. Use the lower part of the graphs-template, which is labelled Load and generation.
2. Find the correct date in the table.
3. Find the corresponding date on the x-axis of the graph.
4. Find the value noted in the table in the column Total Daily $E_{Generated}$, and in the row corresponding to the correct date.
5. Find that value on the y-axis in the graph.
6. Place a mark on the correct day, at the correct value.
7. Draw a line connecting the dot you just made with the dot from yesterday.

Total load: Total Daily E_{Load}

1. Use the lower part of the graphs-template, which is labelled Load and generation.
2. Find the correct date in the table.
3. Find the corresponding date on the x-axis of the graph.
4. Find the value noted in the table in the column Total Daily E_{Load} , and in the row corresponding to the correct date.
5. Find that value on the y-axis in the graph.
6. Place a mark on the correct day, at the correct value.
7. Draw a line connecting the dot you just made with the dot from yesterday.

Share of PV

1. Use the upper boxes at the bottom of the graphs-template.
2. Find the correct date in the table.
3. Find the corresponding date on the x-axis above the boxes.
4. Find the value noted in the table in the column Share of PV, and in the row corresponding to the correct date.
5. Write that number in the upper box on the graphs-template under the correct date.

Weather

1. Use the lower boxes at the bottom of the graphs-template.
2. Find the correct date in the table.

3. Find the corresponding date on the x-axis above the boxes.
4. Find the information about the weather written in the column Logbook in the table, and in the row corresponding to the correct date.
5. Write or draw a symbol representing the general weather in the lower box on the graphs-template under the correct date.

5 Short term evaluation

In order to make any use of the measurements, calculated values and graphs, they must be analysed. The evaluation will help you understand if the system is operated well or not. You will understand if the generation can meet the loads, and you will learn whether or not you can connect more loads to your system without extending the operation of the generator(s). The evaluation can also indicate failures in the system.

The short term evaluation is based on the graphs you have drawn. The evaluation procedure is divided in two parts. The first one is evaluating the battery voltage graph on a short term basis. The second part describes how to analyse the load and generation curves. Both are built up around scenarios and can be used as a dictionary. Therefore you only need to read the parts that are relevant for the scenario you currently find in your graphs.

The short term evaluation of battery voltage should be carried out every day, preferably in the morning so that action can be taken early if needed. By evaluating the system every day, you learn better how to operate the system. If the system is well operated, it will work and serve you longer. The load and generation curves should be analysed when the evaluation of the battery voltage gives you an indication to do so. This is stated in the battery evaluation section. Even if the battery voltage shows no reason for further analysis of the load and generation, it should be carried out once a week. That way you can understand the relations between load, generation and battery voltage, and detect possible errors in the system.

5.1 Battery voltage

To evaluate the battery voltage, the Battery voltage graph is used. The evaluation of the battery voltage should be carried out every day. Batteries that are used incorrectly will be degrading faster. Batteries are expensive, and early breakdowns are therefore costly. If the evaluation is done properly, unfavourable operation of the system can be detected early. The operation can thereby be changed, and failures and unnecessary degradation of the system can be avoided.

The Battery voltage graph template (the top part of the graphs template) has three different areas. These show different important voltage levels. Battery voltage within the white area is good, the grey area is acceptable for shorter periods and dips into the black area should be seldom.

The example graphs used in this section are for 12 V batteries. The graphs should look the same for 24 V and 48 V systems, only the scale on the Battery voltage graph will differ.

5.1.1 Evaluation procedure

The evaluation should be carried out daily according to the following procedure:

1. Look at the graph showing the battery voltage. You can also keep an eye on the graph from last month, for comparison.
2. Find the scenario or the scenarios in the list of battery voltage scenarios that best describe what you see in your graph.
3. Find and read the description for that scenario and follow the given instructions.

5.1.2 Battery voltage scenarios

1. Today's dot is in the white area
2. Today's dot is in the grey or black area, but the dots of previous days are not
3. Today's dot is in the grey or black area, and the dots of previous days are as well
4. The battery voltage is decreasing over time
5. The battery voltage is increasing over time
6. The value of today's measurement is lower than the scale of the template
7. The value of today's measurement is higher than the scale of the template

5.1.3 Descriptions of scenarios

1. Today's dot is in the white area

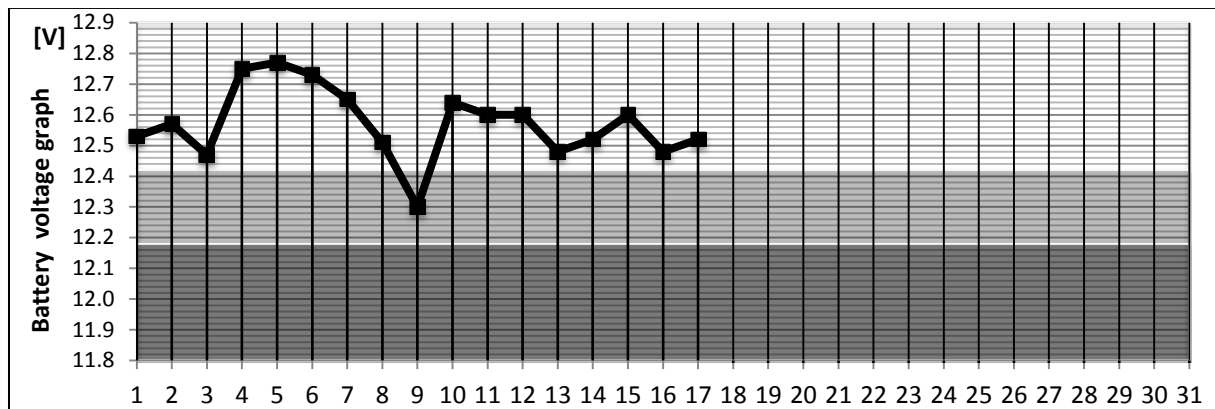

Figure 14: Example graph Scenario 1: Today's dot is in the white area.

Very good! That is where the dots are supposed to be if you want a long lasting system. Continue to use your system as you do now.

If the dots are always high up in the white area, it may be possible to use the generator less or to increase the load. If you are interested in this, carry out analysis of generation and load over a period of time. This will help you to better understand the relations between load and generation. Further instructions and suggestions are given in chapter 5.2 *Load and generation* in the scenario 3 *Stable and high battery voltage*.

2. Today's dot is in the grey or black area, but the dots of previous days are not

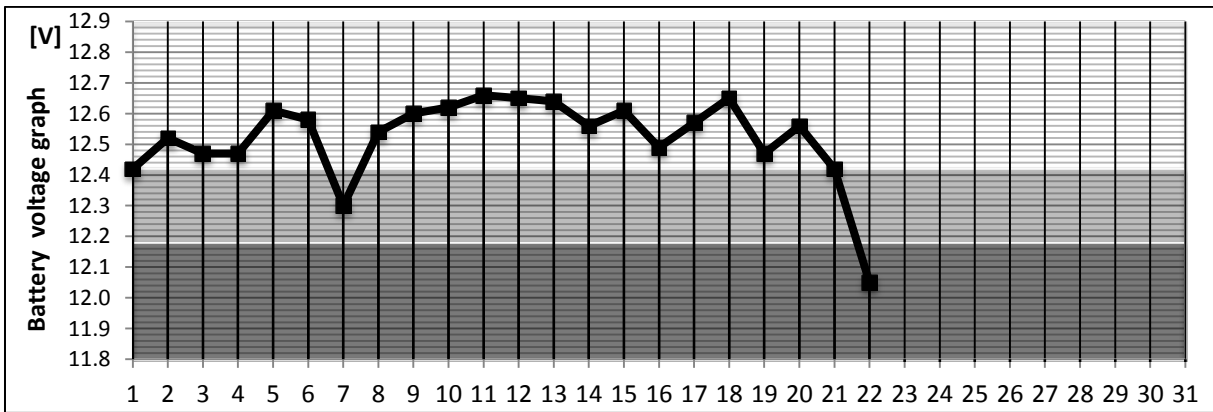

Figure 15: Example graph Scenario 2: Today's dot is in the grey or black area, but the dots of previous days are not.

It is acceptable if this happens sometimes. One or two dips into the black or some three or four dips into the grey area in one month are OK. It should not happen more often though. Many dips into the black and grey areas may damage the batteries. If today's dot is in the grey or black area, and the dots of previous days were in the white area, you do not need to take any action, but you can if you are interested. If you do not take any action, just carefully check the battery voltage again tomorrow. If the battery voltage is increasing immediately after a dip into the black area the batteries are not damaged. If the battery voltage is in the grey or black areas for more than two days in a row, you should consider it to be Scenario 3 *Today's dot is in the grey or black area, and the dots of previous days are as well*. If you are interested in carrying out further analysis of why the battery voltage has decreased, carry out the evaluation described in chapter 5.2 *Load and generation* and use the scenario 1 *Low or decreasing battery voltage*.

3. Today's dot is in the grey or black area, and the dots of previous days are as well

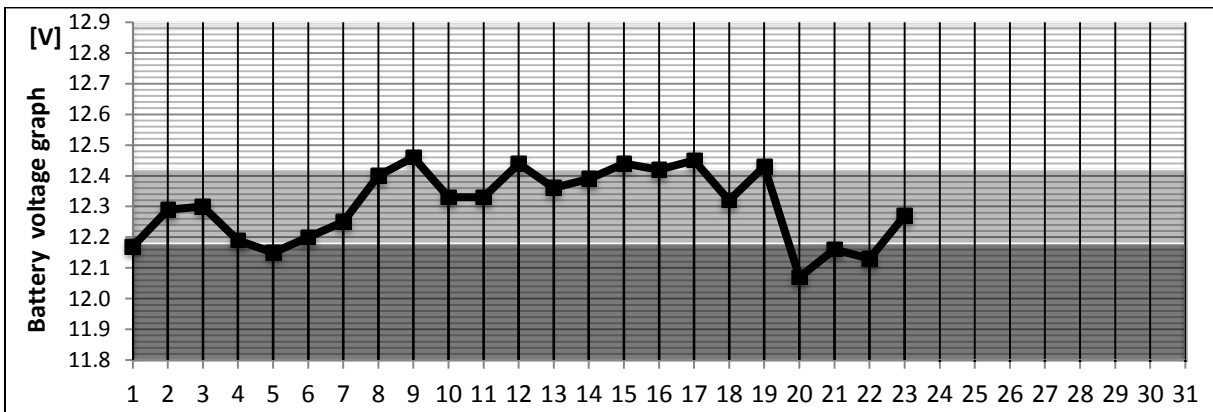

Figure 16: Example graph Scenario 3: Today's dot is in the grey or black area, and the dots of previous days as well.

This scenario is not so good. The batteries are working hard. If you continue like this, the batteries will degrade faster than necessary. In order to figure out how to solve the situation, or if there is anything wrong with your system, you should move on to the analysis of load and generation. Go to chapter 5.2 *Load and generation* and use the scenario 1 *Low or decreasing battery voltage*.

Batteries degrade naturally over time. This means that the battery voltage will be low and stay within the black area if the batteries are close to the end of their lifetime. This will happen eventually even though you are operating your system well. If you have tried to follow the instructions in the evaluation of load and generation, but the voltage does not rise, your batteries are probably damaged. You can still continue to use them as long as the system fulfils your requirements for available electricity. You should ask an electrician to check the status of your batteries though. Maybe they need to be replaced soon.

4. The battery voltage is decreasing over time

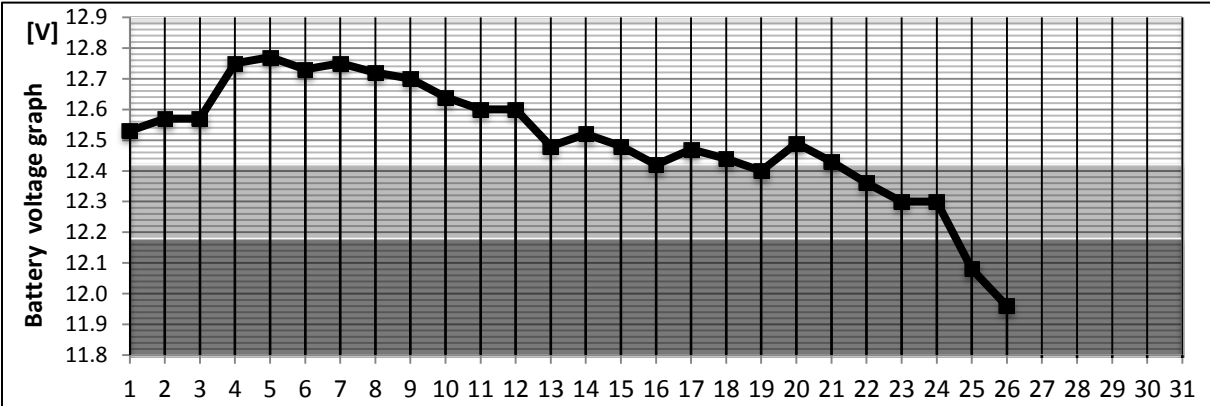

Figure 17: Example graph Scenario 4: The battery voltage is decreasing over time.

This is not good. This means that your batteries are working harder and harder, and that they will fail faster if it continues like this. Try to stop this trend as early as possible, before the battery voltage enters the black section. In order to figure out how, you should move on to the analysis of load and generation in chapter 5.2 *Load and generation* and use scenario 1 *Low or decreasing battery voltage*.

5. The battery voltage is increasing over time

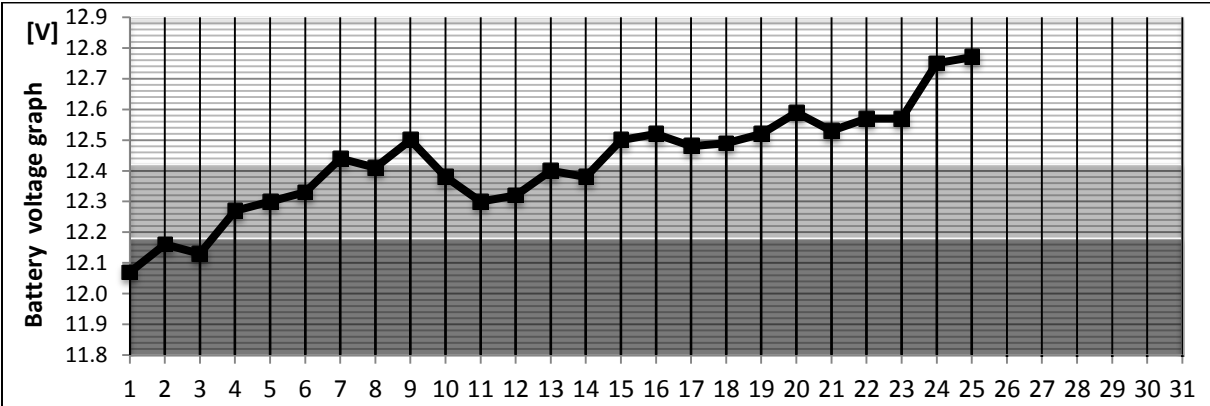

Figure 18: Example graph Scenario 5: The battery voltage is increasing over time.

This is good. It means that your batteries are operating in a healthier and healthier way. You may have seen earlier that the battery voltage was too low, and successfully followed given suggestions. You can continue to use your system the way you do, until the battery voltage is stable in the white area. When this happens, use scenario 1 *Today's dot is in the white area*.

If you know why the battery voltage is increasing, you can get an indication on whether you are now using more fuel or not. It may however also be so that the system is using less energy because some loads or the distribution network are damaged. Further evaluation is not necessary for the operation of the system, but may be interesting. To figure out what causes the increase in battery voltage, you can carry out the evaluation in chapter 5.2 *Load and generation* and use the scenario 2 *Increasing battery voltage*.

6. The value of today's measurement is lower than the scale of the template

If you measure a battery voltage that is lower than the scale you have on the corresponding Battery voltage graph template, something is strange. There are basically two possibilities: either there was a high load connected at the time of the measurement, or the battery voltage is dangerously low.

If there was a high load connected to the system at the time of the measurement, disconnect the load and do the measurement again after 30 minutes. If the value is now on a more normal level, high load was probably the reason for the low voltage measurement. If the sun has already risen when you do the second measurement, you may get too high voltage instead. Try to have less load connected when you do the measurements again the following day.

If there was not any large load connected to the system at the time of the measurement, the battery voltage is dangerously low. Such low voltages can seriously harm the batteries. There should be an automatic function that shall shut down the system if the voltage is this low. If that function has worked, the appliances and lights will not function at the moment. That is good.

If you are still able to use appliances in the system although the voltage is this low, the device that automatically shuts down the power is either not available, broken or bypassed. If so, you should turn off all lights and appliances and contact an electrician.

In order to help the batteries to recover, you can increase generation by turning on the generator. Also turn off all loads, and let the system recover by not having any big loads for the coming days.

7. The value of today's measurement is higher than the scale of the template

If you measure a battery voltage that is higher than the maximum value on the scale of the Battery voltage graph template you use, something is strange. Check if there was generation when the measurement was taken. The measurement may have been taken after sunrise, or when the generator was on. If this is the case, the measurement cannot be used. Try to get proper measurements again the following day.

If the measurement was taken before sunrise and there was no generator on, there was probably an error in the measurement. If you have more ways of measuring the voltage, with for example another voltmeter, try to use that to examine if the voltage measurement device you use is showing accurate values. If the devices show different values, try to figure out with the help of a third one which meter is accurate. If the two devices you have used show the same values, there is probably nothing wrong with your meter. Do your measurements again tomorrow according to the normal procedures, but use both measurement devices. If the values are the same but higher than the maximum value on the scale of the graph template, ask an electrician to help you to figure out what may be wrong.

5.2 Load and generation

If you can understand why the Battery voltage graph looks the way it does, you have a better chance of identifying failures, and making well informed and proper decisions regarding the operation of the system. The graphs showing generation and load will help you.

It is the relationship between the load and the generation that affects the battery voltage. Think of the water system described in section 2.2 *Energy system balance*; if less water is collected than used, the level of water in the storage tank will decrease. If more water is collected than the amount that is used, the water level in the storage tank will increase until the tank is full. The same goes for electrical power systems. Since all systems have losses, a system must generate more electricity than the amount which is consumed. The curve showing generation should thus always (short exceptions are acceptable) be above the curve showing the load.

To evaluate the generated and consumed energy, the load and generation graphs are used together with the boxes at the bottom of the graph-chart showing the weather and the share of PV. Some examples of plotted graphs are shown in *Figure 19*, *Figure 20* and *Figure 21*. The load and generation evaluation will help you understand the relationships between generated energy, consumed energy and battery voltage.

5.2.1 Evaluation procedure

The Load and generation evaluation should be carried out when the battery voltage evaluation suggests you do so. Regardless of whether the battery voltage evaluation suggests you carry out the load and generation or not, it should be done once a week. Follow the following procedure:

- Look at the graph showing the load and the generation. You can also keep an eye on the graph from last month, for comparison.
- Find the scenario or the scenarios in the list of load and generation scenarios that best describe what you see in your graph.
- Find and read the description for that scenario and follow the given instructions.

5.2.2 Load and generation scenarios

1. Low or decreasing battery voltage
 - a. Increasing load
 - b. Decreasing generation
 - c. Generation higher than load
 - d. Collection of less common scenarios
2. Increasing battery voltage
 - a. Decreasing load
 - b. Increasing generation
3. Stable and high battery voltage

Examples of plotted graphs:

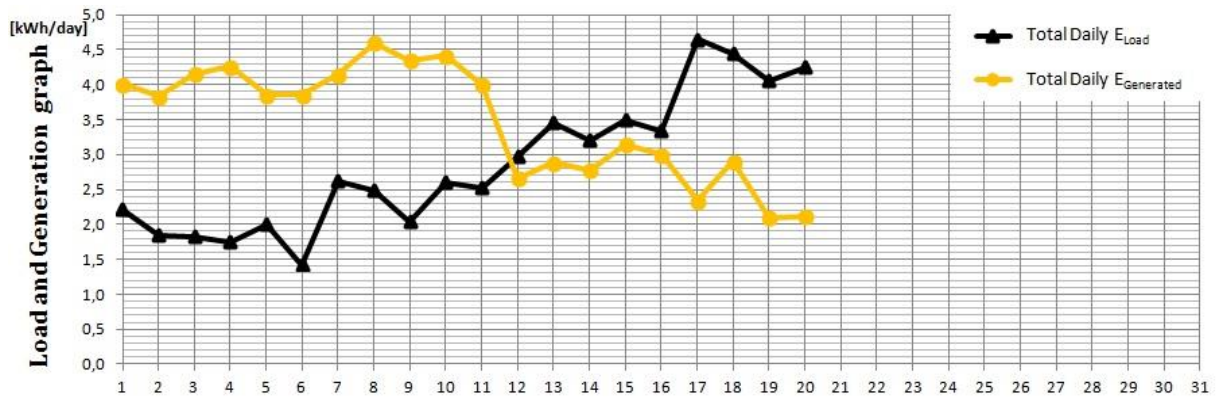

Figure 19: In this example graph, the Total Daily $E_{Generated}$ is first constant and then decreasing, and the Total Daily E_{Load} is increasing. It is not good when the curve for Total Daily E_{Load} is above the curve for Total Daily $E_{Generated}$. In such cases, less energy is generated than used. It is certain that the battery voltage was decreasing during this scenario.

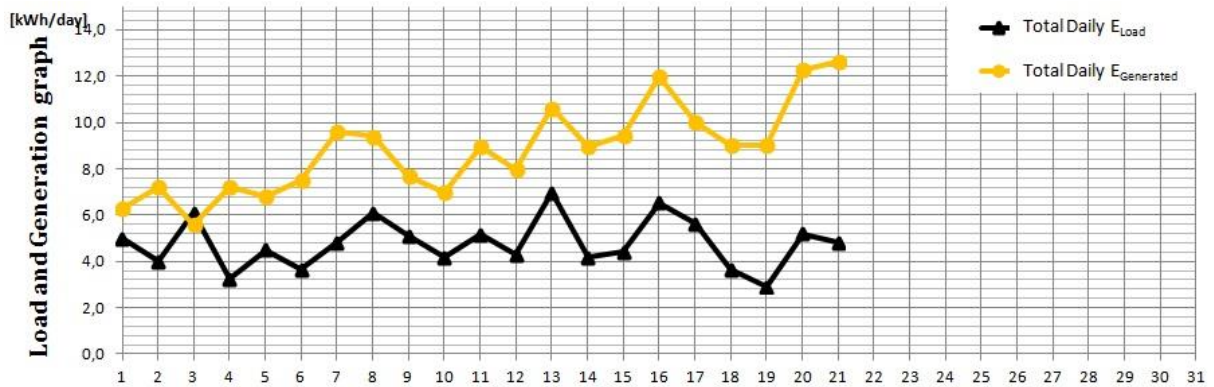

Figure 20: In this example graph, the Total Daily $E_{Generated}$ is increasing slightly, and the Total Daily E_{Load} is constant. One can also see that the two graphs are following one other. It is quite likely that the battery voltage level was already quite high in this scenario, since the generation curve is following the load curve.

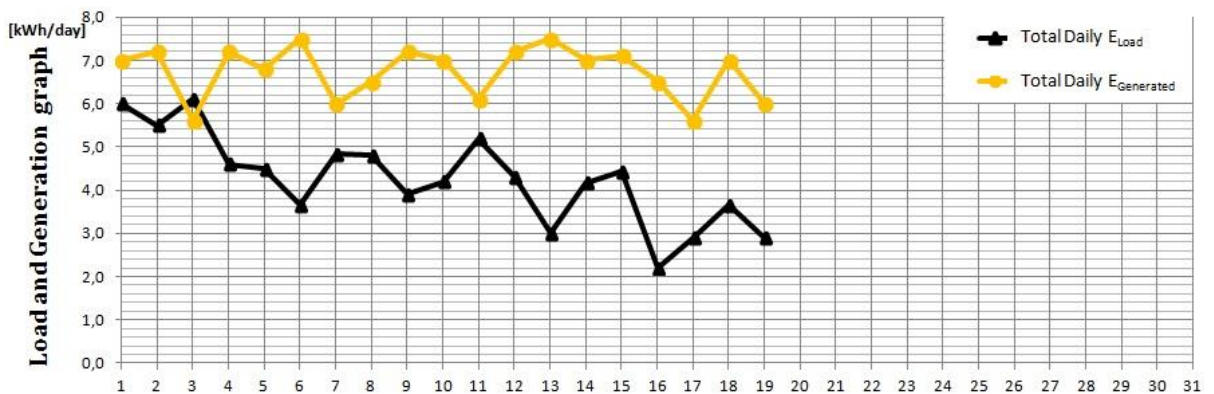

Figure 21: In this example graph, the Total Daily $E_{Generated}$ is constant, and the Total Daily E_{Load} is decreasing. Probably, the battery voltage is increasing during this scenario. It may however also be so that the battery voltage is constant or goes down. This may happen if the PV panels are generating as much energy as they can, and the generator is used similarly every day. In such cases, the generation may not be enough, even if the load has gone down.

5.2.3 Description of scenarios

1.a. Low or decreasing battery voltage. Increasing load

If the battery voltage is decreasing, the load and the losses consume more energy than generated. An increasing load curve shows that more energy is used now than earlier. You have increased the loads to more than your system can handle. Therefore, the system is taking energy from the batteries to sustain the power supply to the loads. That is no problem at all if it happens for shorter times. That is why the system has batteries. The problem comes if the battery voltage is continuing to decrease over several days, or it is approaching the grey or the black areas in the Battery voltage graph.

If the load has increased, try and think of why. Normally, this is due to the use of more appliances, or due to longer operation of electrical appliances. Think of what has happened during the time you see the higher load values. Have you had a large meeting, a celebration, or any other activity that may cause the sudden increase in the use of electrical appliances? Or have you purchased any new power consuming appliance, which is either used a lot or needs a lot of power? May some appliances that are normally turned off have been left on? If you find a natural reason for the increase in energy use (load), consider what you would like to do to increase the battery voltage again. You can either decrease the load again, or use the generator to generate more energy. Prolonged use of the generator will however result in higher fuel consumption and hence higher costs.

Increasing load can also be due to a faulty appliance that consumes more energy than it should. If you can think of any appliance that could be faulty, disconnect it from the system and check the next day if the load value comes down again. You can connect the appliance again after some days to see if the high values come back. If they do, you know that the appliance is consuming a lot of energy. If it did not do that before, it may be faulty. You should repair or replace it.

If you cannot think of any reason why you see the increase or a peak in the load, it may be caused by an error in the system. Check and evaluate the load carefully during the coming days. If the load stays high or continues to increase, but you cannot find a reason for it, consult an electrician.

1.b. Low or decreasing battery voltage. Decreasing generation

If the battery voltage is decreasing, the load and the losses consume more energy than is generated. A decreasing generation curve shows that less energy is generated than before. Therefore, the system is taking energy from the batteries to sustain the power supply to the loads. That is no problem at all if it happens for shorter times. That is why the system has batteries. The problem arises if the battery voltage continues to decrease over several days, or it is approaching the grey or the black areas in the Battery voltage graph.

If the generation has decreased, you should try to understand why. It can be due to less energy from the solar panels, or from the generator. The information in the boxes at the bottom of the graphs chart, Weather and Share of PV, will be used to figure out the reason for the decrease in generation. You can read about the value Share of PV in *4.3 Calculations*.

The decrease in generation can be due to less favourable weather conditions (little sunshine). In this case, it is the generation from PV that has decreased. You can use the Weather-boxes below the

graphs to note the weather. You can also check the Daily E_{PV} values in the table. Was there less sunshine during the days of the decrease in generation than on the days before? Changes in generation due to changing weather conditions are very normal. You cannot do much about that since you cannot, of course, regulate the weather. All you can do is to regulate the load or the use of the generator. Extended use of the generator will cost you money since you will need to use fuel. If possible, it is a good idea to try and adjust the load to the weather. Use appliances that consume a lot of energy mainly when there is a lot of sunshine, or when the generator is on.

Or, could it be that the solar panels are dirty or have been shaded and therefore generated less energy? If the panels are shaded, remove the shading object. If they are dirty, clean them with water and a soft sponge.

The decrease in generation can also be due to less use of the generator. If the number in the box, Share of PV has gone up, it means that the generator has been used less. You can also compare the share of PV you have calculated from the measurements to the design values if you know those. If the calculated numbers are higher than the design value, the generator is used less than the system was designed for. The lower the number in the Share of PV-box, the longer the generator has been used. It is good to limit the use of the generator, since it saves fuel. Your system cannot handle this though. In order to restore the high level of energy in the batteries you have to increase generation again, or decrease the load. Make sure that the battery voltage level returns to high values in the upper part of the white area.

If the share of PV is 0 or very close to 0, it means that there is no, or almost no, generation from the solar panels. It is really rather unlikely that no energy would be generated from the panels in a whole day. It is more likely that there is a fault in the system, implying that the power from the panels is not delivered to the system. Check the fuses if any of them are blown. Blown fuses should be replaced. Also check if any connection is loose. Be very careful not to touch any naked wires. This is dangerous and can lead to serious injuries. If you feel insecure, consult an electrician. Loose connections should be put back in place by skilled person or an electrician. If the share of PV is 0 for a few days, and you cannot find any reason for it, consult an electrician.

If the share of PV is 100, it means that all power came from PV and no energy from the generator(s). If you know you used the generator that day, there is probably some error. For some reason, the energy from the generator did not reach the system. Check fuses and connections. Again, be very careful not to touch any naked wires. If you cannot find any blown fuse or loose connections, do the following check: Turn on the generator. Look at the energy meter showing the energy from generator. Does it register any energy (is the displayed number increasing)? If yes, energy is delivered from the generator. Keep an eye on the share of PV for the coming days. If everything seems normal, it probably is. If the meter does not register any energy, something is probably wrong. Consult an electrician.

If you have an automatic start for your generator and share of PV is 100, you should check if the generator starts at all. Depending on how the system is set up, the generator may start automatically at a specific time, or when the battery voltage comes down to a certain level. Ask the electrician who installed your system how it is regulated. Then, try to understand if the generator is starting according to the specifications. If not, ask an electrician to come and check the generator and the control function of the generator.

1.c. Low or decreasing battery voltage. Generation higher than load

If the generation is only slightly higher than the load, try to increase the generation or reduce the load. The generation must be enough to cover loads but also losses. If this does not work, or if the generation is much higher than the load, one or several cells of the battery can be defective. This may be caused by an internal short circuit. Ask the electrician to come and check it.

1.d. Low or decreasing battery voltage. Collection of less common scenarios

Decreasing battery voltage is most often due to one of the two scenarios described first: increasing load or decreasing generation. The load and the generation can decrease and increase independently from each other though. And, the battery voltage can decrease during almost all combinations of generation and load going up and down.

The internal relation between the load and the generation affects the battery voltage. Think of the balance in the water system and electrical system described in *2.2 Energy system balance*. If the battery voltage (water level in the tank) is decreasing, there is not enough generation (water coming into the tank) to supply the load (water taken from the tap). That is regardless of whether the load and generation go up, down or stay constant. Try to analyse and understand why the voltage has decreased. You can use the explanations for other scenarios in this chapter for support. After you have understood why the battery voltage decreased, you can make a proper decision on how to solve the problem.

If the load appears to be decreasing, the generation increasing and the battery voltage decreasing at the same time, there is an error. The generated power is getting lost somewhere within the system. Consult an electrician to find out what is wrong.

If the load and generation have been constant for a long time, and the battery voltage has also been constant, but suddenly starts to decrease, something is also wrong. There are suddenly more losses in your system. Consult an electrician to find out what is wrong.

2.a. Increasing battery voltage. Decreasing load

The battery voltage will increase if the generated energy is higher than the load and the losses. Increasing battery voltage is good. The batteries are recovering from a period of hard work. A load curve that is decreasing or has a dip shows that the system is using less energy than it did before. This may be due to fewer appliances being used, or that appliances are used for a shorter time. The excess energy will be stored in the batteries, and the battery voltage will thereby go up. It is good for the battery voltage to increase. Since the battery voltage is increasing, the batteries need the extra energy. If the batteries are not allowed to charge to high and stable levels, they will fail faster. Make sure that the battery voltage is high and stable before you connect any more loads. If you need to connect or use more appliances again, you should also increase generation.

Try to understand why the load has decreased/had a dip/was low. Was there a reduction in activities, such as a weekend or holidays with little activities at the time of the load reduction? Was the usage hours of some electrical appliances reduced? Was any appliance disconnected from the system? If you can find a natural reason for the decrease in load, remember that the relation between generation and load must be kept until the battery voltage has increased to stable values in the white area of the graph.

If you cannot find any natural reason to the decrease or dip in load, start to think about possible failures and errors. Could it be that one or more appliances are broken, and therefore no longer use electricity? Or, could there be a disconnection somewhere in the system, implying that some appliances do not get any power delivered to them? Check the installed appliances. If you find appliances that are not functioning, investigate whether the problem is with the power distribution or with the appliance itself:

Try connecting another appliance to the plug where the problem was found. Does the new appliance work? If yes, the problem is with the appliance. If you want to continue to use the appliance, it must be repaired or replaced. If no, the problem can be in the power system. Check for blown fuses. If you find any blown fuse, replace it. Also look for loose connections in the system, but be very careful not to touch any naked wires. This is dangerous and can lead to serious injuries. Loose connections should be put back in place by skilled person or an electrician.

2.b. Increasing battery voltage. Increasing generation

The battery voltage will increase if the generated energy is higher than the load and the losses. An increasing generation curve shows that the system is generating more energy than it did before. The generation can increase either due to more energy from the solar panels, or from the generator(s). The excess energy will be stored in the batteries, and the battery voltage will thereby go up. It is good that the battery voltage increases. Since the battery voltage is increasing, the batteries need the extra energy. If the batteries are not allowed to charge to high and stable levels, they will fail faster. Make sure that the battery voltage continues to increase until high constant levels are reached.

The two parameters Weather and the Share of PV can give you an indication to why you see an increase or a peak in power generation. You can read about the value share of PV in *4.3 Calculations*. The higher the number, the lower the use of the generator.

Increasing generation can be thanks to more power from the solar panels. If the numbers in the Share of PV-boxes increase, the amount of energy from PV has increased. Also look at the Weather-boxes to see if the increase in generation can come from more favourable weather conditions for the solar panels. The panels generate more electricity the more sun that hits them.

Increasing generation can also come from the generator. Look at the numbers in the Share of PV-boxes. If the value in the box is decreasing, the generator contributed more power. If so, it is good that there is enough generation to cover the load and to recharge the battery. If the increase in battery voltage is due to an increased use of the generator, you can consider if it is possible to decrease the load instead. This will have the same effect on the voltage, but save money thanks to less fuel consumption. You can also compare the share of PV you calculate from measured values with the design value of share of PV. This will tell you if the generator is used more or less than it was designed for. A calculated value lower than the design value says that the generator is used more than the system was designed for, and vice versa.

Do not add any loads, unless you also increase generation, until the battery voltage is high and stable. The system needs the excess energy to recharge the batteries.

3. Stable and high battery voltage

It is very good for the batteries always to have high battery voltage. The battery voltage can, however, only rise to a certain level. When the batteries are full, the voltage has reached its maximum value. Stable and high battery voltage may be thanks to careful and good operation of the system. Maybe you have managed to compensate little sunshine and an increasing load with operation of the generator in a very successful way. Or, you may have succeeded in managing your load with regard to the shifting weather conditions. It may, however, also be that the system is over-sized. This is no problem for the long term technical sustainability of the system, but it gives you the opportunity to extend the use of electricity if you wish to. This can be done either by adding more appliances, or by increasing the time of usage. You can possibly also choose to reduce the operation of the generator. A system can be under-used all the time, or during certain periods of time. Those periods of time may be during seasons with favourable weather (sunshine), or during long periods with low loads (for example holidays).

If the battery voltage has been stable in the upper part of the white area of the graph template for a long time, start the analysis by trying to understand if this is a constant or a seasonal phenomenon. Can you see any correlations between the weather and the high battery voltage? Was the battery voltage lower, or the variations greater during a period of time with less sunshine (for example a rainy season)? If yes, the under-use is probably seasonal. If no, the system may be over-sized.

Can you see any correlation between seasonal differences in load and the battery voltage? This may, for example, be low load only during times of school holidays. If yes, the under-use is probably seasonal. If no, the system may be over-sized.

If the high battery voltage does not show any correlation with the weather, can you see any signs of very successful planning of generator operation? Has the generator been used more during times with less sunshine, to compensate for the decrease in generation from PV? If yes, the high battery voltage is not due to an over-sized system, but to successful operation of the system. In that case, you should not try to increase the load unless you are also ready to increase the use of the generator and consequently the fuel consumption.

A third thing to check before trying to increase the load is if the generation curve and the load curve follow each other. Do they go up and down at the same time? That may be thanks to very successful load planning where the loads are adjusted to the current weather. It is however more likely that the system is a little over-sized. (One task of the charge controller is to make sure that the batteries do not get charged too much. This implies that when the batteries are full, the charge controller stops all energy from going from the PV panels to the batteries. When that happens, the system is not using all the electricity that it can from the sun.)

If you have figured out that the high battery voltage is because the system is over-sized, you can try to expand your electricity consumption if you find a need for that. Instead of increasing the load, you can also choose to lower the use of the generator to save fuel. If you wish to increase your electricity consumption, you can either operate existing appliances for a longer time, or install some new appliance. If you are interested in buying new appliances that use a lot of energy, you should ask an electrician to calculate if your system can handle the size of the load, before purchasing anything. The load should, however, only be increased if there is a need for higher energy consumption. For

the long term technical sustainability of the system, adding load has no positive effect unless the added load result in better economic revenue from the system that can be reinvested in the system.

If you increase the load, do this without operating the generator more, and see what happens. If you chose to limit the use of the generator, continue to use the same loads, and see what happens. If the battery voltage stays at the high level over the coming days, the change seems OK (at least at present). If the battery voltage starts to decrease, the system cannot handle the increased load/reduction in generator use. You have to go back to run the system the way you did before (decrease the load again/increase the use of the generator again). If you found that the under-use is seasonal, you can vary load or generation during suitable periods of time. Do not forget to go back to the earlier operation again though when the less suitable times come (rainy season, end of holiday or other identified reasons).

6 Long term evaluation

The long term evaluation helps you to understand if there are any changes over time in the power system. For example the load may have slowly increased, the solar panels may have degraded and generate less power, or there may be an error somewhere in the system that is difficult to detect in the short term evaluation. The long term evaluation should preferably be carried out every month. Data from earlier months or years are compared in the long term evaluation.

Since many evaluated parameters have variations over the year, a yearly evaluation and comparison of different years can also be useful to further understand if there are any slow changes over time in the power system. Therefore, yearly averages of the different parameters in the long term evaluation are also calculated and evaluated. It is also possible to use some of the parameters used in the long term evaluation for comparison with other systems. Values valid for a whole year are especially suitable for such comparisons.

Most parameters used in the long term evaluation are averages of the daily measurements used in the short term evaluation. This means that the values you calculate for the long term evaluation are also, just as the short term evaluation parameters, based on one day. Consequently, the values in the short and the long term evaluations will be of the same magnitude for each parameter. In this way you can get a better feeling for what is normal for your system, and you can react fast when something unusual appears.

For the long term evaluation, there are two different templates. *Template 5: Table for long term evaluation* consists of a table where average values for each month are calculated and noted. In *Template 6: Long term evaluation graphs*, two different graphs are drawn based on the values from the table; Battery voltage, and Load and generation. For the yearly evaluation, there are no separate templates. In *Template 5: Table for long term evaluation* there is space to note the values needed for the yearly evaluation.

This chapter starts with an explanation of the calculations to be carried out. Then follow descriptions of which values to put in the graphs, and how that is done. Thereafter how to evaluate the different calculated and plotted parameters is described. The analysis is divided in eight sections. The first three evaluate the battery voltage, the load and the generation. These three are based on drawn graphs, and resemble the short term evaluation. After this are sections describing how to evaluate the Share of PV, the Normalized PV Yield and the System Losses. The next section is about the fuel consumption, which can be used if fuel consumption has been measured. The last section describes how to evaluate the yearly averages of all parameters. That part is used every time a full year has passed. Each chapter explains possible changes in your system and describes how you can get valuable information to improve the operation of your system.

6.1 Calculations

The long term evaluation is mostly based on calculated averages of the measurements and calculations from the short term evaluation. This section describes how these calculations are performed. To carry out the calculations, values are taken from a filled in sheet *Template 1: Table for*

measured data and short term calculations. All calculated values are to be noted in *Template 5: Table for long term evaluation* found at the end of this guideline.

Monthly Average V_{Batt} [V]

Monthly Average V_{Batt} is the average battery voltage per month. To get the Monthly Average V_{Batt} for one month:

- Add all the measurements of battery voltage V_{Batt} on the sheet *Table for measured data and short term calculations* for the month concerned. Divide the sum you get by the number of values you added (which is the amount of measurements you have).

$$\text{Monthly Average } V_{\text{Batt}} = \frac{\text{Sum of all } V_{\text{Batt}} \text{ measurements of the month}}{\text{The number of values added}}$$

- Write the value you get in the *Table for long term evaluation*. The value should be written in the column Monthly Average V_{Batt} , on the row corresponding to the correct month.

Example 1: You have measured the battery voltage every day in June. When the measured values are added, the sum is 378.6. June has 30 days, and therefore you have 30 measurements.

$$\text{Monthly Average } V_{\text{Batt}} = \frac{378.6}{30} = 12.62 \text{ V}$$

The value you write in the column Monthly Average V_{Batt} , on the row for June is 12.62.

Example 2: You did not manage to measure the battery voltage every day in February. You have measurements for only 22 days. When the measured values are added, the sum is 271.4.

$$\text{Monthly Average } V_{\text{Batt}} = \frac{271.4}{22} = 12.34 \text{ V}$$

The value you write in the column Monthly Average V_{Batt} , on the row for February is 12.34.

Monthly Average Daily E_{PV} [kWh/day]

The Monthly Average Daily E_{PV} is the average of energy generated per day by the PV panels during the month. There are two ways of calculating the Monthly Average Daily E_{PV} . The two alternatives should give you the same number. It is a good idea to make both calculations. If you get the same number, the calculations are proven to be correct.

Alternative 1:

- Add all the Daily E_{PV} measurements on the sheet *Table for measured data and short term calculations* for the month concerned. Divide the sum you get by the number of values you added (which is the amount of measurements you have).

$$\text{Monthly Average Daily } E_{\text{PV}} = \frac{\text{Sum of all Daily } E_{\text{PV}} \text{ measurements of the month}}{\text{The number of values added}}$$

- Write the value you get in the *Table for long term evaluation*. The value should be written in the column Monthly Average Daily E_{PV} , on the row corresponding to the correct month.

Alternative 2:

- Use the filled in sheet *Table for measured data and short term calculations* for this and last month. Take the E_{PV} measurement on the last day of this month, minus the E_{PV} measurement on the last day of last month. Divide the number you get by the number of days in the latter of the two months.

$$\begin{aligned} \text{Monthly Average Daily } E_{PV} &= \\ &= \frac{E_{PV} \text{ on the last day of this month} - E_{PV} \text{ on the last day of last month}}{\text{Number of days in this month}} \end{aligned}$$

- Write the value you get in the *Table for long term evaluation*. The value should be written in the column Monthly Average Daily E_{PV} , on the row corresponding to the correct month.

Example: E_{PV} on June 30 is 345.75. E_{PV} on May 31 is 218.34. June has 30 days.

$$\text{Monthly Average Daily } E_{PV} = \frac{345.75 - 218.34}{30} = \frac{127.41}{30} = 4.25 \text{ kWh/day}$$

The value you write in the column Monthly Average Daily E_{PV} , on the row for June, is 4.25.

Monthly Average Daily E_{Gen} [kWh/day]

The Monthly Average Daily E_{Gen} is the average of energy generated per day by the generator during the month. There are two ways of calculating the Monthly Average Daily E_{Gen} . The two alternatives should give you the same number. It is a good idea to make both calculations. If you get the same number, the calculations are proven to be correct.

Alternative 1:

- Add all the Daily E_{Gen} measurements on the sheet *Table for measured data and short term calculations* for the month concerned. Divide the sum you get by the number of values you added (which is the amount of measurements you have).

$$\text{Monthly Average Daily } E_{Gen} = \frac{\text{Sum of all Daily } E_{Gen} \text{ measurements of the month}}{\text{The number of values added}}$$

- Write the value you get in the *Table for long term evaluation*. The value should be written in the column Monthly Average Daily E_{Gen} , on the row corresponding to the correct month.

Alternative 2:

- Use the filled in sheet *Table for measured data and short term calculations* for this and last month. Take the E_{Gen} measurement on the last day of this month, minus the E_{Gen} measurement on the last day of last month. Divide the number you get by the number of days in the latter of the two months.

$$\begin{aligned} \text{Monthly Average Daily } E_{\text{Gen}} &= \\ &= \frac{E_{\text{Gen}} \text{ on the last day of this month} - E_{\text{Gen}} \text{ on the last day of last month}}{\text{Number of days in this month}} \end{aligned}$$

- Write the value you get in the *Table for long term evaluation*. The value should be written in the column Monthly Average Daily E_{Gen} , on the row corresponding to the correct month.

Monthly Average Total Daily $E_{\text{Generated}}$ [kWh/day]

The Monthly Average Total Daily $E_{\text{Generated}}$ is the average of energy generated per day by the generator and the PV panels together during the month. To calculate the Monthly Average Total Daily $E_{\text{Generated}}$ for one month:

- Add the average daily energy from PV and the average daily energy from the generator(s) that you just calculated and wrote in the table:

$$\begin{aligned} \text{Monthly Average Total Daily } E_{\text{Generated}} &= \\ &= \text{Monthly Average Daily } E_{\text{PV}} + \text{Monthly Average Daily } E_{\text{Gen}} \end{aligned}$$

- Write the value you get in the column Monthly Average Total Daily $E_{\text{Generated}}$, on the row corresponding to the correct month.

Monthly Average Daily E_{LoadAC} [kWh/day]

The Monthly Average Daily E_{LoadAC} is the average of energy used per day by the AC load during the month. There are two ways of calculating the Monthly Average Daily E_{LoadAC} . The two alternatives should give you the same number. It is a good idea to carry out both calculations. If you get the same number, the calculations are proven to be correct.

Alternative 1:

- Add all the Daily E_{LoadAC} measurements on the sheet *Table for measured data and short term calculations* for the month concerned. Divide the sum you get by the number of values you added (which is the amount of measurements you have).

$$\text{Monthly Average Daily } E_{\text{LoadAC}} = \frac{\text{Sum of all Daily } E_{\text{LoadAC}} \text{ measurements of the month}}{\text{The number of values added}}$$

- Write the value you get in the *Table for long term evaluation*. The value should be written in the column Monthly Average Daily E_{LoadAC} , on the row corresponding to the correct month.

Alternative 2:

- Use the filled in sheet *Table for measured data and short term calculations* for this and last month. Take the E_{LoadAC} measurement on the last day of this month, minus the E_{LoadAC} measurement on the last day of last month. Divide the number you get by the number of days in the latter of the two months.

$$\text{Monthly Average Daily } E_{\text{Load AC}} = \frac{E_{\text{Load AC}} \text{ on the last day of this month} - E_{\text{Load AC}} \text{ on the last day of last month}}{\text{Number of days in this month}}$$

- Write the value you get in the *Table for long term evaluation*. The value should be written in the column Monthly Average Daily $E_{\text{Load AC}}$, on the row corresponding to the correct month.

Monthly Average Daily $E_{\text{Load DC}}$ [kWh/day]

The Monthly Average Daily $E_{\text{Load DC}}$ is the average of energy used per day by the DC load during the month. There are two ways of calculating the Monthly Average Daily $E_{\text{Load DC}}$. The two alternatives should give you the same number. It is a good idea to carry out both calculations. If you get the same number, the calculations are proven to be correct.

Alternative 1:

- Add all the Daily $E_{\text{Load DC}}$ measurements on the sheet *Table for measured data and short term calculations* for the month concerned. Divide the sum you get by the number of values you added (which is the amount of measurements you have).

$$\text{Monthly Average Daily } E_{\text{Load DC}} = \frac{\text{Sum of all Daily } E_{\text{Load DC}} \text{ measurements of the month}}{\text{The number of values added}}$$

- Write the value you get in the *Table for long term evaluation*. The value should be written in the column Monthly Average Daily $E_{\text{Load DC}}$, on the row corresponding to the correct month.

Alternative 2:

- Use the filled in sheet *Table for measured data and short term calculations* for this and last month. Take the $E_{\text{Load DC}}$ measurement on the last day of this month, minus the $E_{\text{Load DC}}$ measurement on the last day of last month. Divide the number you get by the number of days in the latter of the two months.

$$\text{Monthly Average Daily } E_{\text{Load DC}} = \frac{E_{\text{Load DC}} \text{ on the last day of this month} - E_{\text{Load DC}} \text{ on the last day of last month}}{\text{Number of days in this month}}$$

- Write the value you get in the *Table for long term evaluation*. The value should be written in the column Monthly Average Daily $E_{\text{Load DC}}$, on the row corresponding to the correct month.

Monthly Average Total Daily E_{Load} [kWh/day]

The Monthly Average Daily E_{Load} is the average of energy used per day by the AC and DC load together during the month. To calculate the Monthly Average Total Daily E_{Load} for one month:

- Add the monthly average daily energy to AC load and DC load that you just calculated and wrote in the *Table for long term evaluation*:

$$\begin{aligned} \text{Monthly Average Total Daily } E_{\text{Load}} &= \\ &= \text{Monthly Average Daily } E_{\text{LoadAC}} + \text{Monthly Average Daily } E_{\text{LoadDC}} \end{aligned}$$

- Write the value you get in the column Monthly Average Total Daily E_{Load} , on the row corresponding to the correct month.

Monthly Average Share of PV [%]

The Monthly Average Share of PV is the percentage of total generated energy that has come from PV during one month. To calculate the Monthly Average Share of PV for one month:

- Use the monthly average daily energy from PV that you have calculated and written in the *Table for long term evaluation*. Divide that value by the monthly average daily energy generated by PV and generator(s) together that you have also calculated and written in the *Table for long term evaluation*. Multiply the number you get by 100 to get the value in %:

$$\text{Monthly Average Share of PV} = \left(\frac{\text{Monthly Average Daily } E_{\text{PV}}}{\text{Monthly Average Total Daily } E_{\text{Generated}}} \right) * 100$$

- Write the value you get in the column Monthly Average Share of PV, on the row corresponding to the correct month.

Monthly Average Normalized PV Yield [kWh/(kW_p, day)]

The Monthly Average Normalized PV Yield is a value showing how much energy (kWh) is generated per installed capacity (kW_p) of PV panels per day. To calculate this value, you need to know the installed capacity of your PV panels. Ask the electrician to give you this value. To calculate the Monthly Average Normalized PV Yield:

- Use the average daily energy from PV that you have calculated and written in the *Table for long term evaluation*. Divide that value by the capacity of installed PV.

$$\text{Monthly Average Normalized PV Yield} = \frac{\text{Monthly Average Daily } E_{\text{PV}}}{\text{Installed capacity of PV}}$$

- Write the value you get in the column Monthly Average Normalized PV Yield, on the row corresponding to the correct month.

Monthly Average System Losses [%]

The Monthly Average System Losses is a value telling you what percentage of the total generated energy has been lost. The way the number is calculated here gives you the average losses during one month. To calculate the Monthly Average System Losses:

- Take the monthly average of daily energy generated by PV and generator(s) together minus the monthly average of daily total load that you have calculated and written in the *Table for long term evaluation*. Divide that value by the average daily energy generated by PV and generator(s) together. Multiply the number you get by 100 to get the value in %:

$$\begin{aligned} \text{Monthly Average System Losses} &= \\ &= \left(\frac{\text{Monthly Average Total Daily } E_{\text{Generated}} - \text{Monthly Average Total Daily } E_{\text{Load}}}{\text{Monthly Average Total Daily } E_{\text{Generated}}} \right) * 100 \end{aligned}$$

- Write the value you get in the column Monthly Average System Losses, on the row corresponding to the correct month.

Monthly Total Fuel Consumption [litre/month]

This value can only be calculated if the use of fuel is measured. The Monthly Total Fuel Consumption tells you how much fuel has been used during one month. To calculate the Monthly Total Fuel Consumption for one month:

If automatic fuel logging is used:

- Take the fuel meter reading from this month, and subtract the reading from last month:

$$\begin{aligned} \text{Monthly Total Fuel Consumption} &= \\ &= \text{This month's fuel reading} - \text{Last month's fuel reading} \end{aligned}$$

- Write the value you get in the column Monthly Total Fuel Consumption, on the row corresponding to the correct month in the *Table for long term evaluation*.

Example 1: You are using automatic logging. The logger is placed at the fuel intake to the generator engine. You have read the fuel meter on the first day of every month. In the logbook, on the first of August, you find the value for 2675. You go back to the first of July, and read the value 2477.

$$\text{Monthly Total Fuel Consumption} = 2675 - 2477 = 198 \text{ litres}$$

If manual fuel logging is used:

- Add up all fuel fills for the last month. Add the fuel that was left in the tank on the first day of last month. Subtract the fuel that is left in the tank on the first day of this month:

$$\begin{aligned} \text{Monthly Total Fuel Consumption} &= \\ &= \text{Last month's fuel fills} \\ &+ \text{Remaining fuel in the tank on the first of last month} \\ &- \text{Remaining fuel in the tank on the first of this month} \end{aligned}$$

- Write the value you get in the column Monthly Total Fuel Consumption, on the row corresponding to the correct month in the *Table for long term evaluation*.

Example 2: You want to find the fuel consumption for December. You add up all fuel fills that are noted in the logbook in December. The value you get is 75 litres. On the first of January, you had estimated or measured that 2 litres were left in the tank. This number was noted in the logbook. On the first of December, you had estimated the amount of fuel in the tank to 10 litres. This value was noted in the logbook as well.

$$\text{Monthly Total Fuel Consumption} = 75 + 2 - 10 = 83 \text{ litres}$$

Monthly System Fuel Consumption [litre/kWh]

This value can only be calculated if the use of fuel is measured. The Monthly System Fuel Consumption tells you how much fuel has been used per used amount of energy (load) during one month. To calculate the Monthly System Fuel Consumption for one month:

- Use values in *Table for long term evaluation*. Multiply the average total daily load by the number of days of the month. Divide the Monthly Total Fuel Consumption by the number you get:

$$\begin{aligned} \text{Monthly System Fuel Consumption} &= \\ &= \frac{\text{Monthly Total Fuel Consumption}}{(\text{Monthly Average Total Daily } E_{\text{Load}} * \text{number of days of the month})} \end{aligned}$$

- Write the value you get in the column Monthly System Fuel Consumption, on the row corresponding to the correct month in the *Table for long term evaluation*.

Example:

The Monthly Average Total Daily E_{Load} in September was 16.3 kWh/day. September has 30 days. The Monthly Total Fuel Consumption for September was 38 litres.

$$\text{Monthly System Fuel Consumption} = \frac{38}{(16.3 * 30)} = \frac{38}{489} = 0.078 \text{ litres}$$

Monthly Generator Fuel Consumption [litre/kWh]

This value can only be calculated if the use of fuel is measured. The Monthly Generator Fuel Consumption tells you how much fuel has been used per amount of energy generated by the generator during one month. To calculate the Monthly Generator Fuel Consumption for one month:

- Use values in *Table for long term evaluation*. Multiply the monthly average of daily energy generated by the generator by the number of days in the month. Divide Monthly Total Fuel Consumption by the number you get:

$$\begin{aligned} \text{Monthly Generator Fuel Consumption} &= \\ &= \frac{\text{Monthly Total Fuel Consumption}}{(\text{Monthly Average Total Daily } E_{\text{Gen}} * \text{number of days of the month})} \end{aligned}$$

- Write the value you get in the column Monthly Generator Fuel Consumption, on the row corresponding to the correct month in the *Table for long term evaluation*.

Logbook

Although there is no specific logbook field in the template, it may be a good idea to note down extraordinary things that may have occurred during the month which you think can influence any of the measured and evaluated parameters. Such things may be “extremely sunny and dusty”, “many large seminars”, “very many surgeries”, “new computers” or “heavy rains, no sun”. The notes can help you remember things that have happened, which will be valuable for the evaluations on monthly as well as on yearly basis. The notes can for example be written in the template, by each month.

Averages for the year

After a year is complete, it is recommended that yearly averages of the different parameters are calculated and evaluated. The only calculations required for the yearly evaluation are averages of the values used in the long term evaluation.

- The yearly averages of the monthly values are calculated as the sum of all values, divided by the number of values.

$$\text{Yearly Average} = \frac{\text{Sum of all values from January to December}}{\text{The number of values added}}$$

- Write the value you get in the corresponding column, on the darker, separate row labelled Average for the year in the *Table for long term evaluation*.

Example 1: You have the Monthly Average V_{Batt} for all months. When you add all the Monthly averages, the sum is 151.05. Since you have values for all months, you divide by 12:

$$\text{Yearly Average } V_{\text{Batt}} = \frac{151.05}{12} = 12.59 \text{ V}$$

Example 2: You have managed to measure the fuel consumption and calculate the Monthly Average System Fuel Consumption for January, February, April, May, June, July, September, October and December, but not for March, August and November. When you add the values that you have (for January, February, April, May, June, July, September, October and December), the sum is 1.38. The number of values added is the same as the number of months you have measurements for, that is 9. The Yearly Average System Fuel Consumption is therefore:

$$\text{Yearly Average System Fuel Consumption} = \frac{1.38}{9} = 0.15 \text{ litres/kWh}$$

6.2 Plot the calculated values in graphs

Some of the monthly averages of the different parameters are plotted in graphs. The values are found in *Template 5: Table for long term evaluation*. The template for long term evaluation graphs is *Template 6: Long term evaluation graphs*.

For further guidance on how to plot values from a table in a graph, use *Figure 13* and the section about battery voltage in chapter 4.4 *How to plot the obtained values in a graph*.

The values to be plotted in graphs are the following:

Monthly Average battery voltage: Monthly Average V_{Batt}

1. Use the upper part of the graphs-template, labelled Battery voltage.
2. First, fill in the scale of the y-axis (vertical). Use the same scale as you have used in the graphs for the short term evaluation of battery voltage (for 12 V, 24 V or 48 V systems).
3. For each month, find the corresponding value in the column Monthly Average V_{Batt} in the table.
4. Mark the value in the graph template.
5. Connect the dots with a line.

Monthly Average daily generated energy: Monthly Average Total Daily $E_{\text{Generated}}$

1. Use the lower part of the graphs-template, labelled Load and Generation.
2. First, fill in the scale of the y-axis (vertical). Use the same scale as you have used in the graphs for the short term evaluation of Load and Generation.
3. For each month, find the corresponding value in the column Monthly Average Total Daily $E_{\text{Generated}}$ in the table.
4. Mark the value in the graph template.
5. Connect the dots with a line.

Monthly Average daily load: Monthly Average Total Daily E_{Load}

1. Use the lower part of the graphs-template, labelled Load and Generation.
2. For each month, find the corresponding value in the column Monthly Average Total Daily E_{Load} in the table.
3. Mark the value in the graph template.
4. Connect the dots with a line.

6.3 Evaluation

The long term analysis should be carried out every month. This is to find slow changes going on in the system, which cannot be seen in the short term evaluation. Use graphs and tables from the previous months and years.

After each year, it is also recommended that an evaluation of the average values of the year is carried out. That evaluation is similar to the long term evaluation. The suggestions are described in chapter 6.3.8 *Yearly evaluation*.

The following parameters will be evaluated:

- Battery voltage
- Load
- Generation
- Share of PV
- Normalized PV Yield
- System Losses
- Fuel Consumption

6.3.1 Battery voltage

Look at the battery voltage graphs you have drawn in *Template 6: Long term evaluation graphs*. Use the graph for the current year together with older graphs. Try to see if you find any overall tendency regarding the average battery voltage. The following possible scenarios are described below:

1. Average battery voltage stays constant over time
2. Average battery voltage is decreasing slowly over time
3. Average battery voltage suddenly decreases
4. Average battery voltage is increasing over time

1. Average battery voltage stays constant over time

That is good. The battery voltage should stay constant and high during the first years of operation. That will happen if the system has been well operated throughout.

2. Average battery voltage is decreasing slowly over time

Batteries do not have unlimited lifetime. They degrade over time. As a consequence, the average battery voltage is likely to go down over the years. This is a normal process. If the system is operated properly, it should, however, take several years for the battery voltage to decrease into the grey area. Towards the end of the battery lifetime the battery voltage will be approaching the black area in the evaluation graphs. When this happens, you may already have noticed that your system is not working as well as before. Maybe you have started to experience blackouts. When the average battery voltage in the long term evaluation graph is starting to approach the black area, you will soon need to invest in new batteries if you want to continue to operate your system. Typical battery lifetime is between 5 and 10 years, depending on the battery type and the operational conditions.

If the battery voltage starts to decrease significantly as soon as within the first year or two, the batteries are degrading faster than normal. If you think you have operated your system well, you should contact the manufacturer and check the guarantee terms. What you can do is to run your system very carefully, and hope that the batteries have not been degrading too much. Use the short term evaluation for guidance.

When the batteries have degraded and the average battery voltage has been in the black area for several months, there is little you can do retrospectively. The batteries are probably at the end of their lifetime. You can ask an electrician to check the batteries in order to get a better estimation of their status. You can, however, use the system with the degraded batteries as long as the system is fulfilling your needs. Eventually the batteries will barely store any energy at all though, so be prepared to invest in new ones shortly.

3. Average battery voltage suddenly decreases

If there is a sudden drop in the average battery voltage, you have probably already noticed it in the short term valuation. Something has happened that seems to have harmed the batteries. Ask an electrician to check if the problem is with all batteries or maybe only with one. The electrician can probably also help you find a solution to the problem.

The drop in average battery voltage could also be due to a sudden increase in load or decrease in generation. This you would probably have noticed in the short term evaluation though and taken action against.

4. Average battery voltage is increasing over time

If the average battery voltage is increasing over some time, it may be a sign that you are operating your system in a better and better way. That is good. You are probably following the suggestions in the short term evaluation successfully. Due to the natural degradation of batteries, an increase in battery voltage is not very likely to happen in the very long run though.

6.3.2 Load

Look at the load graphs you have drawn in *Template 6: Long term evaluation graphs*. Use the graph for the current year together with older graphs. Try to see if you find any overall tendency regarding the average load. The load can vary between different months due to seasonal variations in activities. If your system is at a school, for example, you may see a lower load during months with school holidays. As for the short term evaluation, try to understand the changes you see in the graphs by trying to connect them to things happening at the site of the system. Notes can help you remember. The following possible scenarios are described below:

1. Total load is constant over time
2. Total load is decreasing over time
3. Total load is increasing over time

1. Total load is constant over time

If no new appliances are installed, no appliances have broken or were removed, and the appliances are used to the same extent all the time, the load will stay constant. After some years of operation, a system may be able to handle a smaller load than it did when it was new though. This is due to the degradation of the batteries. If you see that the battery voltage tends to decrease, you can start limiting your load if possible, especially at times with no power generation (when there is no sunshine and no generator is on). You can also consider replacing loads that are not so energy efficient by newer more efficient ones. This will give your batteries some extra lifetime.

2. Total load is decreasing over time

Your system load is becoming smaller. It may be due to the use of fewer appliances, or to less use of installed appliances. Another possibility is that old loads were replaced by more energy efficient loads, for example energy efficient lamps.

After some years of operation, a system may only be able to handle a smaller load than it did when it was new. That is due to the degradation of the batteries. The decreasing load may consequently be a conscious choice by the operator, after suggestions in the short term evaluation.

3. Total load is increasing over time

If more and more appliances are installed, and/or appliances are used for longer and longer times, the load will increase. This is happening at many places, especially during the first years after the installation of the system. Generally this is not a bad thing, but you need to be careful and be sure that your system is designed to handle the increasing load. Carry out the short term evaluation carefully, and keep an eye on the battery voltage.

6.3.3 Generation

Look at the generation graphs you have drawn in *Template 6: Long term evaluation graphs*. Use the graph for the current year together with older graphs. Also the Average Share of PV in the table for long term evaluation will be used.

Compare the generation graph with the load graph and the battery voltage graph. From the short term evaluation you know how load, generation and battery voltage influence one another. Try to understand why the curves look the way they do and how they have influenced each other.

The Average Share of PV can help you understand if the generation comes from PV or from the generator(s). If the share of PV is increasing, more power is generated by the PV panels. If it is decreasing, more comes from the generator(s).

The following possible scenarios are described below:

1. The total generation is constant over time
2. The total generation is increasing over time
3. The total generation is decreasing over time

1. The total generation is constant over time

If there are no large changes in load, generation will also be constant. This keeps the battery voltage constant.

Generated power can come either from PV or from a generator. The generation from PV can vary between different months due to seasonal variations in weather. During sunny months, the PV panels generate more power. During rainy seasons with a lot of clouds, the panels generate less. Since the graph shows constant generation, differences in generation from PV seem to have been well compensated by more or less use of the generator. If this is the case, no changes will be seen in the average generation in the long term evaluation. Instead, the changes will be visible in the share of PV. Can you see any correlations between the values showing Average Share of PV for the month and the seasons? The more energy that has come from PV, the higher is the Average Share of PV.

2. The total generation is increasing over time

Increasing generation can be caused either by increased use of the generator or by more power from the PV modules. By using the Average Share of PV value, you can understand where the increase in generation comes from in your case.

If the share of PV is decreasing, the generator was used more. Maybe there is a correlation between seasons with less sunshine and the increased use of the generator. It may also be that the generator was simply used more, regardless of seasonal variations in PV generation.

If the Average Share of PV is going up, more power comes from the PV panels. You can perhaps notice a correlation between the increase in generation from PV and seasonal variations in sunshine that you are aware of.

The increase in generation can also be due to increasing load. Compare the generation curve and the load curve to check if that is the case. If it is, it may be explained by two scenarios: the PV panels managed to generate the power for the increased load, or, the generator was used more in order to compensate for the increasing load. Maybe you have managed to schedule loads to times when there is a lot of sunshine, and therefore you see an increase in load and increase in generation at the same time.

3. The total generation is decreasing over time

Generation can decrease due to less power from PV, or due to less use of the generator. You can find out by looking at the share of PV and at the values for generated power from PV and generator if the decrease in generation is due to less power from PV or the generator.

A decreasing share of PV indicates that the decrease in generation is due to less power from PV. That may happen during less sunny seasons, when the panels cannot generate as much power as they can when the sun is shining a lot. Can you relate the decrease in generation to such seasons? It may also happen if the panels are shaded, dirty or broken and therefore cannot generate as much energy as before. If you have followed the suggestions in chapter 2.4 *Maintenance*, you have probably noticed if the panels were shaded or dirty, and hopefully the problem was fixed. If you see decreasing generation from PV, you can, however, still check that the panels are not shaded or dirty. Also make a visual inspection of the panels. If one or more panels have spots that look different from the rest of the panels, ask an electrician to check the panel to see if it is still performing well.

Increasing Average Share of PV tells you that the generation has probably decreased due to less operation of the generator.

Also compare the generation curve with the load curve. Decreasing generation may be due to decreasing load. If the load is decreasing, the system does not need as much energy, and the generation is therefore automatically going down. If that is happening, and the battery voltage is still high, you can try to decrease the use of the generator during times of low load. In the section 3 *Stable and high battery voltage* in chapter 5.2.2 *Load and generation scenarios* you can read more about what to check before decreasing the generator use.

It is important that the battery voltage is not decreasing when the generation is decreasing. If it is, follow the instructions given in chapter 5 *Short term evaluation* in order to get the battery voltage back up again.

6.3.4 Share of PV

Look at the Share of PV filled into the *Template 5: Table for long term evaluation*. You have already used the Share of PV to understand changes in generation, both in the short and the long term evaluation. You can also study the Share of PV separately though. This can tell you if you have used the generator(s) more or less than the amount the system was designed for. On a day-to-day basis, this does not really make sense since the generator(s) may be used differently on different days. That is why it has not been discussed much in the short term evaluation. On a monthly basis though, it can give you valuable information about how your system is operated. Ask the electrician who designed the system what share of PV your system was designed for. By knowing the design value, you can understand if the generator is used more or less than the electrician designed the system for. If the number you calculate is higher than the design value, it means that the generator(s) is used less than the system was designed for, and vice versa. You can also look at seasonal variations to see if your use of the generator(s) corresponds to months with a lot of load, or seasons with little sunshine. If this is the case, you have probably managed to plan the use of the generator successfully.

6.3.5 Normalized PV Yield

Look at the Normalized PV Yield filled into the *Template 5: Table for long term evaluation*. The normalized PV Yield tells you how much energy your system has generated from PV per installed capacity of PV. The “normal” level very much depends on weather conditions. In a sunny environment near the equator, the number may reach 5-7 kWh/kW_p per day. During a rainy season or cloudy days, the number may be going down to levels around 1 kWh/kW_p per day.

The value may also be affected by system configurations, i.e. how the PV panels are connected to each other. If the panels are shaded or dirty, the value will go down. Also, if the system is not using all the capacity from the PV panels due to already full batteries, the value will be lower. That means that if your system is oversized and not using its full capacity, you will see lower Normalized PV Yield. If the short and long term evaluation tells you that the system has capacity for further load, you can consider connection of further load if desired. On *page 38* in the *Short term evaluation* is further described how to proceed with connection of further load.

The Normalized PV Yield was, as you probably have noticed, not calculated in the short term evaluation. Since the Normalized PV Yield varies a great deal with the climate and weather, it can only give you very indicative information about changes in your system. Daily values are therefore of limited interest. What you can do though is to compare the Normalized PV Yield of your system to other systems in the nearby area. This can be done on a monthly basis, or yearly. Just be careful that you are comparing the same things on the different systems.

A system with a lower value utilizes the sunshine less efficiently than a system with a higher number. A higher number means that a lot of the energy in the sunshine is utilized in the system. A high number is hence good from a system efficiency point of view. The system was more properly sized, is working more efficiently, and the investment cost was lower than if the system was oversized. A risk though with a system with high Normalized PV Yield is that it may be undersized. If the system must always use all the sunshine that is available, it may be that the batteries are often not fully charged. You should therefore not only consider it as a positive sign if the normalized PV yield of your system is high compared to systems in the nearby area, but also evaluate the battery voltage and the load and generation. It may, however, also be that the system was designed to only power a limited part of its required energy by PV, and a lot by the generator(s). You can figure out if that is the case by looking at the design value of Share of PV. If that number is low, the system was designed to get a lot of its energy from the generator(s). The system may still use a lot of energy from the sun, hence having a high Normalized PV Yield, but be working well according to how it was designed.

6.3.6 System Losses

Look at the System Losses filled in on the *Template 5: Table for long term evaluation*. The System Losses is a value telling you what percentage of the total generated energy has been lost. This is therefore the amount of energy that the system has generated from PV and the generator(s) that has “disappeared” and could not be used.

Losses are unavoidable in a PV-diesel hybrid system. You can read more about common losses in chapter 2.2 *Energy system balance*. They occur in system components such as charge controllers, inverters and batteries. Losses are dependent on the quality and status of the system components,

as well as the operation of the system. If loads are used mainly at times when there is no generation, the system will have higher losses than if loads are typically used at the same time as there is generation. This is due to losses in the batteries. If the energy is consumed when it is generated, the battery losses can be partly avoided.

Although it is not possible to completely avoid losses, they should be as small as possible for a well-functioning system. If the losses are increasing, it is a sign that there is something that may not be functioning properly. If the short term evaluation has been carried out carefully, you may have noticed a failure that can be a reason for the increasing losses. You can also carry out the maintenance in chapter 2.4 *Maintenance* and possibly find something not working properly. If the losses are increasing fast or reach levels over 30 %, you should ask an electrician to evaluate your system.

As you have probably also noticed, this value was not calculated and used for the short term evaluation. The reason is that the value does not take into consideration that some energy has been stored in the batteries. The System Losses value would thus indicate that the energy that has been stored in the batteries from one day to the next has “disappeared”. On a day-to-day basis, the value would therefore not give any valuable information if calculated every day. Also on a monthly basis, the value will consider the energy stored in the batteries as a loss. The difference in stored energy from one month to another, compared to all energy that was generated and used during that month is, however, much less and will therefore not influence the System Losses values so much.

The System Losses can also be used to compare your system with other PV and PV hybrid systems. A system with small losses functions better and more efficiently than a system with high losses. Remember though that systems with different components and a different use will naturally have a different sized loss.

6.3.7 Fuel Consumption

Look in *Template 5: Table for long term evaluation*. If fuel consumption has been measured, investigations related to the system and generator fuel consumption can be carried out. Generator Fuel Consumption is how much fuel the generator is using per kWh of energy it generates. System Fuel Consumption on the other hand shows how much fuel the system has used per kWh of used energy, distributed as AC and DC load. These numbers have the advantage that they can be used to compare different systems and generators with each other. That is not possible with the most other parameters used in this evaluation.

A well-functioning diesel generator has a Generator Fuel Consumption of 0.3-0.4 litre/kWh if operated well. It is common, though, in small systems to have higher fuel consumption. The fuel consumption for a diesel generator should, however, not approach 1 litre/kWh. If you are using another fuel in your generator, the standard consumption in litre/kWh may be different. The product manual may give you more exact figures of the generator’s fuel consumption.

The Generator Fuel Consumption will be higher if the generator has many starts and stops, or if it is running with a low load. If the value is higher than the suggested 0.3-0.4 litre/kWh, your generator is

consuming more fuel than it should need to. That can be due to many starts and stops or that the generator is running on a low load. It may also be a sign that the generator needs maintenance.

The System Fuel Consumption depends on how good the generators are, how they are used, and how much they are used and also how much the PV panels are generating and how large losses the system has. If the System Fuel Consumption is increasing, more fuel has been used per kWh of used energy. This may be due to choices to run the generator more, to enable higher loads. You may see seasonal variations in the System Fuel Efficiency. At times with less sunshine, the number will probably go up.

If you wish to compare the System Fuel Consumption of your system with other systems, be aware that the only thing the number tells you is how much fuel you use, in order use a certain amount of energy. This very much depends on the system design and how the system is operated. Even if you compare two identical systems, there will be differences. If one of the two systems has more load, naturally the generator will be used more and the System Fuel Consumption will be higher.

6.3.8 Yearly evaluation

Since many evaluated parameters have variations over the year, evaluation and comparison of different years can make slow changes easier to detect. Therefore, yearly averages of the different parameters in the long term evaluation are also calculated and evaluated. The comparison of years is, of course, only possible after some years of operation when there are values to compare. Some of the parameters in the long term evaluation can also be used for comparison between different systems. For this, it is usually better to use values representing a full year than values representing a shorter time period.

To carry out evaluation of the yearly averages of parameters, use the yearly averages that you have calculated and written in the section called *Average of the year* in the *Template 5: Table for long term evaluation*. Compare values for as many years as you have. There are no graphs prepared for the yearly evaluation. If you feel that graphs would help you, you can create your own graphs by either modifying the templates provided for short and long term evaluation, or by making your own.

The suggested yearly evaluation does not contain any step by step instructions on what to look at and what to do, as the short term evaluation does. Since you will have worked with system evaluation for at least one complete year when you look at the yearly averages, you are now experienced in system evaluation and can probably decide what to take into consideration and draw your own conclusions. To evaluate the different parameters, go through the different parameters with the help of the long term evaluation that you have used every month.

The discussions in the long term evaluation related to seasonal variations can no longer be applied, although differences from year to year will be visible in the values. If one year was exceptionally sunny for example, and the next year had a lot of clouds and rain, you will probably be able to see the difference in your values. If you have noted down extraordinary things that have happened to for example load or generation, these notes can help you understand the numbers you evaluate.

If you wish to compare your system to other systems, make sure that the values that you are comparing are comparable. First, the relevant measurements must have been taken the same way.

For example; the values required for System Losses are here measured before the energy enters the charge controller (energy from PV) and the AC charger (energy from generator) but after the energy has passed the inverter (energy to load). System Losses thus include losses from charge controller, inverter and AC charger. If another system has its measurement equipment placed differently, the System Losses value will not include the same losses. The System Losses will in such a case appear smaller although they may not be so, Comparison between systems with different measurement configurations will not give valuable results.

Secondly, parameters that sound like the same thing may have been calculated differently. If you wish to compare values from different systems, make sure that the calculations are done in the same way. Otherwise, you will be comparing two things that do not contain the same information.

When comparing different systems, it is also important to check that compared values have the same units. Fuel consumption may for example be expressed in gallons or litres per kWh or Wh. If the units are different, it is often possible to convert one of the values to the unit of the other one. It may also be so that one value contains data from a longer time period. The load, for example, may be expressed as kWh per day in one guideline. Somebody using another evaluation method may express their load in kWh per year, for example.

Lastly, verify that the two values you wish to compare are considering the same time frame. The Normalized PV Yield for example can be very much higher during the sunniest month of the year than the over the whole year in average. It is recommended that values considering full years are compared, especially in comparisons between systems located in different climatic zones.

7 In case of a blackout

There are many different possible causes of a complete blackout. Some of them can be identified by some simple checks, other have to be examined by an electrician. It is important that you note every blackout in the logbook. If a blackout happens, take all measurements and note them in the table. You can write the values at the bottom of the chart, in order not to mix them with the ordinary measurements. Remember to add date and time.

Here follows a set of things to check in case of a blackout. They may help you localize the cause of the blackout and find a solution to it.

- **Check the battery voltage** immediately when there is a blackout. If the voltage is under the lowest value on the battery voltage graph scale you use (11.8, 23.6 or 47 V), it is good that your system has caused a blackout. There is too little generation and too little energy stored in the battery to supply the load. Therefore, the charge controller or the inverter has shut down your system, in order to prevent the batteries from being seriously damaged. What you should do immediately is to turn off all appliances, and make sure that the system is recovering to high battery voltage as soon as possible. The system will work again after the batteries have been charged to a certain level. That will be before the batteries are completely full though. If you want your batteries to be operating well for a long time, you must make sure that the voltage rises to high levels again as soon as possible. Therefore, let the system rest with minimum load for some days, until the battery voltage is again stable and high. You can also choose to run the generator. Still, you must make sure that the battery voltage rises to stable levels within the white area before the system is operated normally again.

You should go through the evaluation procedure in chapter 5 *Short term evaluation* in order to understand why this happened. It is not good for the system if this happens, so you should try to avoid it in the future. In the future, check your system more carefully with the short term evaluation procedure so that this does not happen again. If you are operating your system well, and follow the recommendations in the short term evaluation, and there are still frequent blackouts due to low voltage, your batteries are probably old or damaged. They need to be replaced. Ask your electrician for advice.

- **Check all fuses** in the system. Are any of them blown? If you need an explanation on different types of fuses, read about fuses in chapter 2.1 *System components*. There are many reasons for a fuse to blow. If a fuse blows only once you do not need to worry much. Replace/reset it and continue to use the system as you did before. If a fuse blows immediately again after you have replaced/reset it there is a failure in the system that needs to be identified and fixed. If the same fuse blows on a regular basis, there is also something wrong that must be identified and fixed. In both cases, carry out the error identification in the next paragraph, and contact an electrician if you cannot find the error.

If it is a fuse to load that has blown, you may have too large a load connected. Start the error identification process by turning off all appliances that are connected to the blown fuse. Then replace/reset the fuse. If the fuse blows again immediately, you probably have a short

circuit in the system. You should leave the fuse broken and call an electrician. If the fuse does not blow, check all the appliances that were connected to the blown fuse if any of them looks damaged. If you do not find any damaged appliance, you can try to turn on appliances again, one by one. The fuse may have blown due to too a high load, or due to a short circuit within a device connected to the system. If you suspect that you had too many things connected to the system, you should avoid connecting so many things again. If not, turn on the devices you used just before the blackout, one by one, to see if the fuse blows again when you turn on any specific device. If it does, that device may have some error. Disconnect the device and change/reset the fuse again. The device must be checked and repaired before being connected to the system again.

If it is a fuse on the line from the generator or the PV modules that blows repeatedly, there may be a short circuit somewhere. Ask an electrician to detect the error.

- **Check PV charge controller, inverter and AC charger** for obvious failures such as deformation, unusual temperature, smoke and so on. If any of this is noticed, call an electrician. Also check if all displays are showing figures or lights as usual. If one or more displays show error codes, write the error code in the logbook. Thereby you might help an electrician to find the problem. If the display of one of the devices does not show any figures at all or the usual lights are not lit, you may suspect that that device is damaged. It may also be only the display or light that is damaged though. If the inverter shows no figures, and all AC loads connected to the inverter are cut off, there is probably something wrong with the inverter. If the charge controller displays no figures or lights, and the blackout is affecting the DC load, the charge controller is probably broken. You need to contact an electrician to come and look at the device.
- **Check the system for loose connections** by touching the isolated wires. Be very careful not to touch any naked wires. This is dangerous and can lead to serious injuries and death. If you detect loose cables, they must be reconnected. If you are not used to electrical work, you should call an electrician who can solve the problem. The electricity to the point that somebody is working on must always be turned off.

If you did all the checks mentioned above and documented everything in the logbook but still cannot find a reason for the blackout, call an electrician. He or she needs to do further error diagnostics. In order to make work easier for him or her show your logbook and your previous measurements in tables and graphs.

8 Afterword

The International Energy Agency (IEA), founded in November 1974, is an autonomous body within the framework of the Organization for Economic Co-operation and Development (OECD) that carries out a comprehensive programme of energy co-operation among its 23 member countries. The European Commission also participates in the work of the Agency. The IEA Photovoltaic Power

Systems Programme (IEA-PVPS) is one of the collaborative R & D agreements established within the IEA and, since 1993, its participants have been conducting a variety of joint projects in the applications of photovoltaic (PV) conversion of solar energy into electricity.

The 23 participating countries are Australia (AUS), Austria (AUT), Belgium (BEL), Canada (CAN), China (CHN), Denmark (DNK), France (FRA), Germany (DEU), Israel (ISR), Italy (ITA), Japan (JPN), Korea (KOR), Malaysia (MYS), Mexico (MEX), the Netherlands (NLD), Norway (NOR), Portugal (PRT), Spain (ESP), Sweden (SWE), Switzerland (CHE), Turkey (TUR), the United Kingdom (GBR) and the United States of America (USA). The European Commission, the European Photovoltaic Industry Association, the US Solar Electric Power Association and the US Solar Energy Industries Association are also members. An Executive Committee composed of one representative from each participating country or organization heads the overall programme. The management of individual Tasks (research projects / activity areas) is the responsibility of Operating Agents. Information about the active and completed tasks can be found on the IEA-PVPS website www.iea-pvps.org

Task 9, Deploying PV services for regional development, addresses the use of PV as a means to enhance regional development – both for rural electrification applications, and more broadly in the urban environment. The Task achieves this by developing partnerships with appropriate regional and national organizations plus funding agencies, and carrying out work on specific applications of interest and relevant business models.

The use of PV hybrid systems has great potential in remote mini- and micro-grids. To be long term sustainable though, projects must be carried out with care through planning, design, implementation and operation. Rather frequently, micro-grids fail due to unfavourable system operation, causing unnecessary component replacement costs and loss of time with electricity. This guideline is suggested as a tool for users and operators of PV-diesel hybrid micro grids with limited possibilities for carrying out extensive data collection and analysis. It offers a way to better understand if a system is operated well, and gives suggestions on how to act if there are signs of unfavourable use or failure.

The work preceding this guide has been carried out by Corinna Fritz at Ulm University of Applied Sciences and Frank Fiedler and Caroline Bastholm at Solar Energy Research Center (SERC) at Dalarna University. Fritz, Fiedler and Bastholm have developed the user guide together, and Bastholm has undertaken the writing of this report. The user guide has received valuable contributions from several members of the International Energy Agency Photovoltaic Power Systems Programme (IEA-PVPS) Task 9 and other associated international experts. Special thanks are due to Peter Ahm (PA Energy Ltd), Erik Lysen (Lysen Consulting), Georg Bopp (Fraunhofer ISE), Brice Nicolas, Anjali Shanker, Grégoire Lena and Silvia Puddu (IED), Sven Ruin (TEROC), Friedemar Schreiber (Fraunhofer ISE), Jean-Christian Marcel (MJC PV Consulting), Stavros Pressas and John Pappas (NSE Ltd). Many thanks also to Marcos Morales Pallares (DU) and Matthew Matimbwi (Tanzania Renewable Energy Association) for reading and giving valuable comments on drafts of the user guide.

Calculations to be carried out and noted in the template:

$$\text{Daily } E_{PV} = E_{PV} \text{ Today} - E_{PV} \text{ Yesterday}$$

$$\text{Daily } E_{Gen} = E_{Gen} \text{ Today} - E_{Gen} \text{ Yesterday}$$

$$\text{Total Daily } E_{Generated} = \text{Daily } E_{PV} + \text{Daily } E_{Gen}$$

$$\text{Daily } E_{LoadAC} = E_{LoadAC} \text{ Today} - E_{LoadAC} \text{ Yesterday}$$

$$\text{Daily } E_{LoadDC} = E_{LoadDC} \text{ Today} - E_{LoadDC} \text{ Yesterday}$$

$$\text{Total Daily } E_{Load} = \text{Daily } E_{LoadAC} + \text{Daily } E_{LoadDC}$$

$$\text{Share of PV} = \left(\frac{\text{Daily } E_{PV}}{\text{Total Daily } E_{Generated}} \right) * 100$$

Year: _____

Template 5: Table for long term evaluation

Month	Monthly Average V_{Batt} [V]	Monthly Average Daily E_{PV} [kWh/day]	Monthly Average Daily E_{Gen} [kWh/day]	Monthly Average Total Daily $E_{Generated}$ [kWh/day]	Monthly Average Daily E_{LoadAC} [kWh/day]	Monthly Average Daily E_{LoadDC} [kWh/day]	Monthly Average Total Daily E_{Load} [kWh/day]	Monthly Average Share of PV [%]	Monthly Average Normalized PV Yield [kWh/kW _p , day]	Monthly Average System Losses [%]	Monthly Total Fuel Consumption [litre/month]	Monthly System Fuel Consumption [litre/kWh]	Monthly Generator Fuel Consumption [litre/kWh]	Sign
January														
February														
March														
April														
May														
June														
July														
August														
September														
October														
November														
December														
Average for the year														

Calculations to be carried out and noted in the template:

$$\text{Monthly Average } V_{Batt} \text{ [V]} = \frac{\text{Sum of all measured } V_{Batt} \text{ on one month's Table for measured data and short term calculations}}{\text{Number of measurements that were summed up}}$$

$$\text{Monthly Average Daily } E_{PV} \text{ [kWh/day]} = \frac{\text{Sum of all measured Daily } E_{PV} \text{ on one month's Table for measured data and short term calculations}}{\text{Number of measurements that were summed up}}$$

$$\text{Monthly Average Daily } E_{Gen} \text{ [kWh/day]} = \frac{\text{Sum of all measured Daily } E_{Gen} \text{ on one month's Table for measured data and short term calculations}}{\text{Number of measurements that were summed up}}$$

Year: _____

Monthly Average Total Daily $E_{\text{Generated}}$ [kWh/day] = Monthly Average Daily E_{PV} + Monthly Average Daily E_{Gen}

Monthly Average Daily E_{LoadAC} [kWh/day] = $\frac{\text{Sum of all measured Daily } E_{\text{LoadAC}} \text{ on one month's Table for measured data and short term calculations}}{\text{Number of measurements that were summed up}}$

Monthly Average Daily E_{LoadDC} [kWh/day] = $\frac{\text{Sum of all measured Daily } E_{\text{LoadDC}} \text{ on one month's Table for measured data and short term calculations}}{\text{Number of measurements that were summed up}}$

Monthly Average Total Daily E_{Load} [kWh/day] = Monthly Average Daily E_{LoadAC} + Monthly Average Daily E_{LoadDC}

Monthly Average Share of PV [%] = $\left(\frac{\text{Monthly Average Daily } E_{\text{PV}}}{\text{Monthly Average Total Daily } E_{\text{Generated}}} \right) * 100$

Monthly Average Normalized PV Yield [kWh/(kW_p, day)] = $\frac{\text{Monthly Average Daily } E_{\text{PV}}}{\text{Installed capacity of PV}}$

Monthly Average System losses [%] = $\left(\frac{\text{Monthly Average Total Daily } E_{\text{Generated}} - \text{Monthly Average Total Daily } E_{\text{Load}}}{\text{Monthly Average Total Daily } E_{\text{Generated}}} \right) * 100$

Automatic fuel logging:

Monthly Total Fuel Consumption [litre/month] = This month's fuel reading – Last month's fuel reading

Manual fuel logging:

Monthly Total Fuel Consumption [litre/month] = Last month's fuel fills + Fuel in the tank on the first of last month – Fuel in the tank on the first of this month

Monthly System Fuel Consumption [litre/kWh] = $\frac{\text{Monthly Total Fuel Consumption}}{(\text{Monthly Average Total Daily } E_{\text{Load}} * \text{number of days of the month})}$

Monthly Generator Fuel Consumption [litre/kWh] = $\frac{\text{Monthly Total Fuel Consumption}}{(\text{Monthly Average Total Daily } E_{\text{Gen}} * \text{number of days of the month})}$

Average for the year: When the whole year has passed, calculate the yearly average for all the values in the table.

Year: _____

Template 6: Long term evaluation graphs

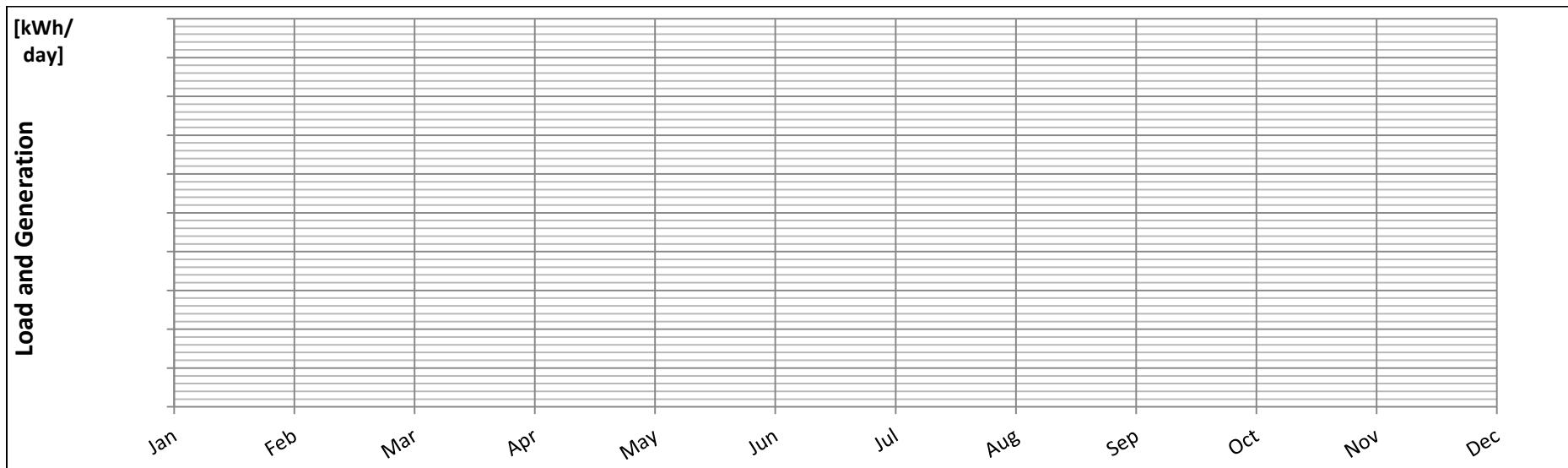
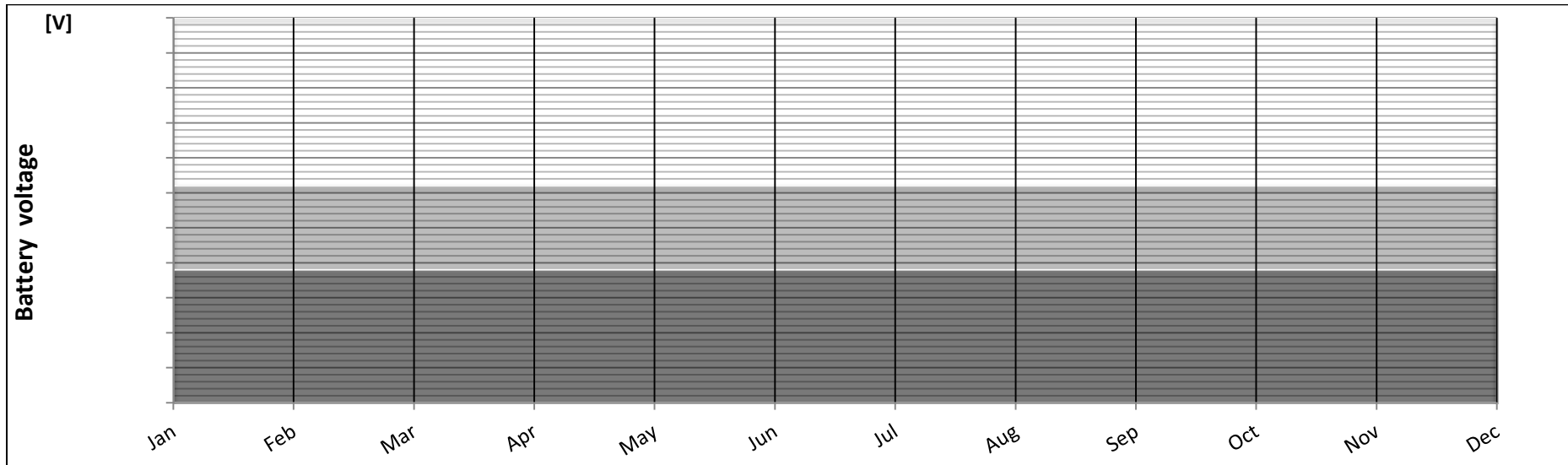

Give feedback on the guideline

At the time of publication, the guideline had never been tested on any real case. It was developed based on experiences from field work and literature. We are grateful to all PV-diesel hybrid system users who are interested in applying the guideline, and we highly appreciate all feedback.

If you are interested in sharing your thoughts about the guideline with us, we would be happy to get to know the following:

- **Applicability of the guideline:** Are the guideline and the system descriptions in the guideline relevant for the system type you have? Did you need to modify the guideline for your own application?
- **The level of knowledge needed:** Are the content and the explanations easy to understand, possible to understand after getting used to the guideline, or too difficult?
- **The measurements:** Is it easy, or difficult to take the measurements? Are the measurement routines working well in your organization? Is it easy or difficult to use the table templates and do the calculations?
- **Evaluation:** Are the graphs useful? Do the scales on the graphs work well for your system? Do the evaluation routines work well in your organization? Are the evaluation intervals (daily, monthly, yearly) suitable for you?
- **The usefulness of the guideline:** Has the guideline helped you? Can you see any improvements in system operation since you started using the guideline?
- **Anything unnecessary:** Is there anything in the guideline that we could take out?
- **Anything missing:** Is there anything we have forgotten to consider in the guideline?

In order to further understand your answers, we would very much like to also get some information about the system you are using, and your organization:

- **The technical system:** How much PV is installed in your system (kWp)? How large generators does your system have (kW or kVA)? On an average, how many hours per day are the generators operated? Does the system have an AC or a DC distribution network or both? Please tell us as much as possible about system components and system specifications.
- **Place:** Where is your system located? In which country? At what type of organization? Please tell us as much as possible about the place where the system is used.
- **Loads:** What is your system used for? Computers, light, refrigerators, hospital equipment? Please tell us as much as you can about the load size and type, number of connected households etc.
- **Who works with the system:** Do you have certain people appointed to work with the system? What are their functions, education and experiences of power systems?
- **Contact information:** We would very much appreciate your contact information. If you don't mind, we may get back to you and ask you further questions.

Thank you!

Please send your feedback to Caroline Bastholm

E-mail: caroline.bastholm@du.se

Phone: +46 23 77 87 28

Address: Dalarna University
791 88 Falun, Sweden



ISBN 978-3-906042-40-4



9 783906 042404 >